

DISPLAY THIS CARD ON PRINCIPAL FRONTAGE OF WORK
CITY OF PORTLAND

Please Read Application And Notes, If Any, Attached

BUILDING INSPECTION
PERMIT

PERMIT ISSUED
Permit Number: 061006
JUL 11 2006
CITY OF PORTLAND

This is to certify that RYAN STEVEN D & GERALDYN M JTS /Maine Window & Manro
has permission to remove a non conforming sun room and placing an 11' x 11' open deck, amended permit #051331
AT 75 DEEPWOOD DR L 397 C012001

provided that the person or persons firm or corporation accepting this permit shall comply with all of the provisions of the Statutes of the State and of the Ordinances of the City of Portland regulating the construction, maintenance and use of buildings and structures, and of the application on file in this department.

Apply to Public Works for street line and grade if nature of work requires such information.

Notification of inspection must be given and when permission is procured before this building or part thereof is occupied or closed-in. 4 HOUR NOTICE IS REQUIRED.

A certificate of occupancy must be procured by owner before this building or part thereof is occupied.

OTHER REQUIRED APPROVALS

Fire Dept. _____
Health Dept. _____
Appeal Board _____
Other _____
Department Name

[Signature] 7/10/06
Director - Building & Inspection Services

PENALTY FOR REMOVING THIS CARD

City of Portland, Maine - Building or Use Permit Application

389 Congress Street, 04101 Tel: (207) 874-8703, Fax: (207) 874-8716

Permit No: 06-1006	Issue Date: 07/10/2006	CBL: 397 C012001
-----------------------	---------------------------	---------------------

Location of Construction: 75 DEEPWOOD DR	Owner Name: RYAN STEVEN D & GERALYN	Owner Address: 75 DEEPWOOD DR	Phone:
Business Name:	Contractor Name: Maine Window & Sunroom	Contractor Address: 71 Portland Rd. Kennebunk	Phone: 2079852300
Lessee/Buyer's Name	Phone:	Permit Type: Amendment to Single Family	Zone: R2

Past Use: Single Family home	Proposed Use: Same removing a sunroom and replacing w/ an 11' x 15' open deck, amends permit #051331
--	--

FIRE DEPT: <input type="checkbox"/> Approved <input type="checkbox"/> Denied <i>N/A</i>	INSPECTION: Use Group: <i>R23</i> Type: <i>5B</i> <i>7/10/06</i>
Signature:	Signature:

Proposed Project Description:
remove a non conforming sunroom and replacing w/ an 11' x 15' open deck, amends permit #051331

PEDESTRIAN AC

Action: Approved Approved w/Conditions Denied

Signature: _____ Date: _____

Permit Taken By: mjn	Date Applied For: 07/10/2006	Zoning Approval	
--------------------------------	--	------------------------	--

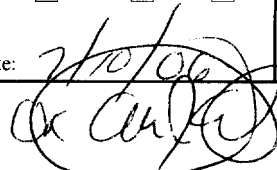
<ol style="list-style-type: none"> This permit application does not preclude the Applicant(s) from meeting applicable State and Federal Rules. Building permits do not include plumbing, septic or electrical work. Building permits are void if work is not started within six (6) months of the date of issuance. False information may invalidate a building permit and stop all work.. 	Special Zone or Reviews <input type="checkbox"/> Shoreland <input type="checkbox"/> Wetland <input type="checkbox"/> Flood Zone <input type="checkbox"/> Subdivision <input type="checkbox"/> Site Plan Maj <input type="checkbox"/> Minor <input type="checkbox"/> MM <input type="checkbox"/> Date: <i>7/10/06</i>	Zoning Appeal <input type="checkbox"/> Variance <input type="checkbox"/> Miscellaneous <input type="checkbox"/> Conditional Use <input type="checkbox"/> Interpretation <input type="checkbox"/> Approved <input type="checkbox"/> Denied Date: _____	Historic Preservation <input type="checkbox"/> Not in District or Landmark <input type="checkbox"/> Does Not Require Review <input type="checkbox"/> Requires Review <input type="checkbox"/> Approved <input type="checkbox"/> Approved w/Conditions <input type="checkbox"/> Denied Date: _____
			

CERTIFICATION

I hereby certify that I am the owner of record of the named property, or that the proposed work is authorized by the owner of record and that I have been authorized by the owner to make this application as his authorized agent and I agree to conform to all applicable laws of this jurisdiction. In addition, if a permit for work described in the application is issued, I certify that the code official's authorized representative shall have the authority to enter all areas covered by such permit at any reasonable hour to enforce the provision of the code(s) applicable to such permit.

SIGNATURE OF APPLICANT	ADDRESS	DATE	PHONE
RESPONSIBLE PERSON IN CHARGE OF WORK, TITLE		DATE	PHONE

BUILDING PERMIT INSPECTION PROCEDURES

Please call 874-8703 or 874-8693 to schedule your inspections as agreed upon

Permits expire in 6 months, if the project is not started or ceases for 6 months.

The Owner or their designee is required to notify the inspections office for the following inspections and provide adequate notice. Notice must be called in **48-72** hours in advance in order to schedule an inspection:

By initializing at each inspection time, you are agreeing that you understand the inspection procedure and additional fees from a "Stop Work Order" and "Stop Work Order Release" will be incurred if the procedure is not followed as stated below.

A Pre-construction Meeting will take place upon receipt of your building permit.

- Footing/Building** Location Inspection: Prior to pouring concrete
- Re-Bar** Schedule Inspection: Prior to pouring concrete
- Foundation** Inspection: Prior to placing ANY backfill
- Framing/Rough** Plumbing/Electrical: Prior to any insulating or drywalling
- Final/Certificate** of Occupancy: Prior to any occupancy of the structure or use. NOTE: There is a \$75.00 fee per inspection at this point.

Certificate of Occupancy is not required for certain projects. Your inspector can advise you if your project requires a Certificate of Occupancy. All projects DO require a final inspection

If any of the inspections do not occur, the project cannot go on to the next phase, REGARDLESS OF THE NOTICE OR CIRCUMSTANCES.

~~CERTIFICATE OF OCCUPANCIES MUST BE ISSUED AND PAID FOR, BEFORE THE SPACE MAY BE OCCUPIED~~

[Signature]
Signature of Applicant/Designee

7/10/06
Date

[Signature]
Signature of Inspections Official

7-11-06
Date

CBL: 397-C-12

Building Permit #: 051331

All Purpose Building Permit Application

If you or the property owner owes real estate or personal property taxes or user charges on any property within the City, payment arrangements must be made before permits of any kind are accepted.

Location/Address of Construction: 75 Deepwood Drive		
Total Square Footage of Proposed Structure 11 x 15 deck (165 sq. ft.)	Square Footage of Lot	
Tax Assessor's Chart, Block & Lot Chart# 397 Block# C Lot# 12	Owner: Steven and GERALYN Ryan	Telephone: 878-0834
Lessee/Buyer's Name (If Applicable)	Applicant name, address & telephone: Maine Window + Sunroom 91 Industrial Park Rd. Saco, ME 04072 985-2300 x 211	cost Of Work: \$6,227.95 Fee: \$
<p>Approximately how long has it been vacant: _____</p> <p>Proposed use: outside deck</p> <p>Project description:</p>		
<p>Contractor's name, address & telephone: Maine Window + Sunroom, 91 Industrial Park Rd, Saco, ME 04072 985-2300 x 211</p> <p>Who should we contact when the permit is ready: Don Hathorn</p> <p>Mailing address: 91 Industrial Park Rd., Saco, ME 04072</p> <p>We will contact you by phone when the permit is ready. You must come in and pick up the permit and review the requirements before starting any work, with a Plan Reviewer. A stop work order will be issued and a \$100.00 fee if any work starts before the permit is picked up. PHONE: 985-2300 x 211</p>		

IF THE REQUIRED INFORMATION IS NOT INCLUDED IN THE SUBMISSIONS THE PERMIT WILL BE AUTOMATICALLY DENIED AT THE DISCRETION OF THE BUILDING/PLANNING DEPARTMENT, WE MAY REQUIRE ADDITIONAL INFORMATION IN ORDER TO APPROVE THIS PERMIT.

I hereby certify that I am the Owner of record of the named property, or that the owner of record authorizes the proposed work and that I have been authorized by the owner to make this application as his/her authorized agent. I agree to conform to all applicable laws of this jurisdiction. In addition, if a permit for work described in this application is issued, I certify that the Code Official's authorized representative shall have the authority to enter all areas covered by this permit at any reasonable hour to enforce the provisions of the codes applicable to this permit.

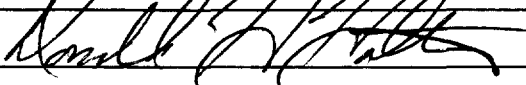
Signature of applicant: 	Date: 7/7/06
--	---------------------

This is NOT a permit, you may not commence ANY work until the permit is issued.
If you are in a Historic District you may be subject to additional permitting and fees with the Planning Department on the 4th floor of City Hall

City of Portland, Maine - Building or Use Permit

389 Congress Street, 04101 Tel: (207) 874-8703, Fax: (207) 874-8716

Permit No: 06-1006	Date Applied For: 07/10/2006	CBL: 397 C012001
------------------------------	--	----------------------------

Location of Construction: 75 DEEPWOOD DR	Owner Name: RYAN STEVEN D & GERALYN	Owner Address: 75 DEEPWOOD DR	Phone:
Business Name:	Contractor Name: Maine Window & Sunroom	Contractor Address: 71 Portland Rd. Kennebunk	Phone: (207) 985-2300
Lessee/Buyer's Name	Phone:	Permit Type: Amendment to Single Family	

Proposed Use: Same removing a sunroom and replacing w/ an 11' x 15' open deck, amends permit #051331	Proposed Project Description: remove a non conforming sunroom and replacing w/ an 11' x 15' open deck, amends permit #051331
--	--



Dept: Building **Status:** Approved with Conditions **Reviewer:** Mike Nugent **Approval Date:** 07/10/2006
Note: **Ok to Issue:**

1) Final allowable width of deck will be determined prior to setting of piers, once setback compliance is determined.



Department of Building Inspections
City of Portland
389 Congress St.
Portland, Maine 04101

To Whom It May Concern:

We are applying for a permit to disassemble a sunroom that did not meet the set back requirement and restore a deck. We have gone through the appeals process with no success. As a result, we must remove the sunroom and deck then restore the property to its original condition.

The room will be dismantled by hand and removed from the site. The deck the room was built on will be reconfigured from a 15' x 21' to a 15' x 11'. The framing to the deck will remain with existing concrete piers. The new deck is to have composite decking, a privacy fence and vinyl handrails.

We would like to proceed as soon as possible. *Thank* you for your time and attention to this matter.

Sincerely,

Donald Hathorn
Installation Manager

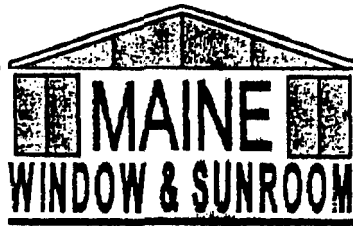

"We Treat Your Home Like Our Own."

DATE: 7-11-05

JOB NAME & ADDRESS:

Stephen Ryan
75 Deepwood Dr
Portland, ME 04103

STEVEN
I, Stephen Ryan, hereby authorize Maine Window & Sunroom to act as my agent to acquire a building permit for my home improvement project.

Stephen Ryan
Signature

Established 1989

71 Portland Road • Kennebunk, ME 04043 • 207-985-2300 • 800-564-5858 • 207-985-1691 Fax

www.mainewindowsunroom.com

75 DEEP WOOD DRIVE

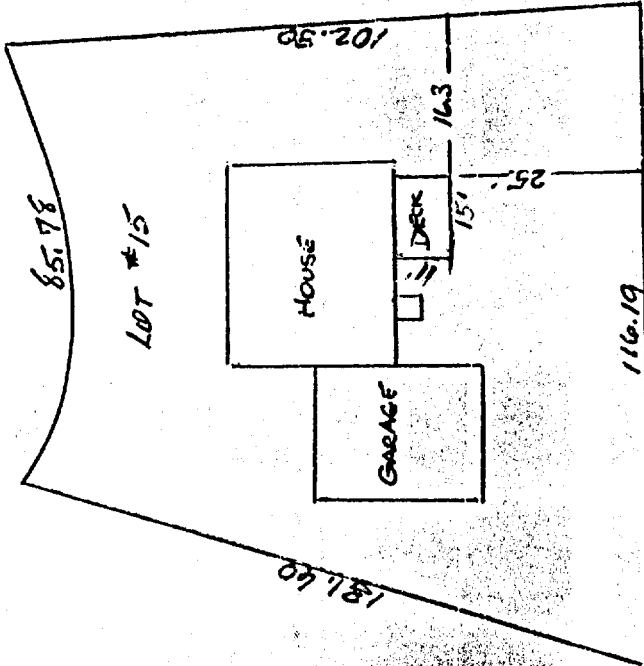

STEVEN RYAN PROPERTY

180"

2 X 8 Joists
16" OC

1/4" Sandpaper
2x10 Beam

10" Sounding Hole
48" in ground
Spaced 10'
mark Run
E. prior

2x10
Charging Deck

2x10
Double Rim

Composite
Decking

45" To Grade

75 Deepwood Dr., Portland
JOB ADDRESS

Steven Ryan
JOB NAME

Deck Detail

STAIR

Detail

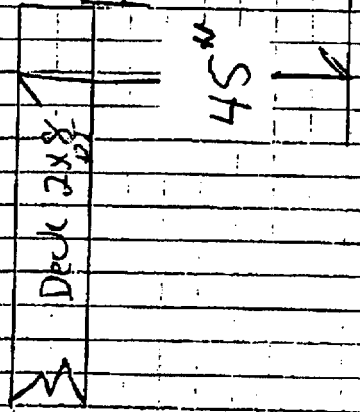

Risers = 7 1/2

Treads = 11

Stringer cut out of 2x12 pt

Risers will be covered with 1x8 pt

Treads will be 3/4 x 6 pt Decking Boards

Not
Drawn
to
Scale

DEPT. OF BUILDING INSPECTION
CITY OF PORTLAND, MAINE
OCT 26 2005
RECEIVED

CITY OF PORTLAND, MAINE
APPROVED CONSTRUCTION PLANS
OCT 2 2005
SUPERSEDES ALL
PRIOR DATED PLANS

Steven Ryan

DEPT. OF BUILDING INSPECTION
CITY OF PORTLAND, ME
OCT 26 2005
RECEIVED

CITY OF PORTLAND MAINE
APPROVED CONSTRUCTION PLANS
OCT 27 2005
SUPERSEDES ALL
PRIOR DATED PLANS

Railing Detail

- * Railing will be 36" High measured vertically off the outer most nosing of any step
- * There will be a railing on both sides of the stairs
- * There will be a grippable Rail

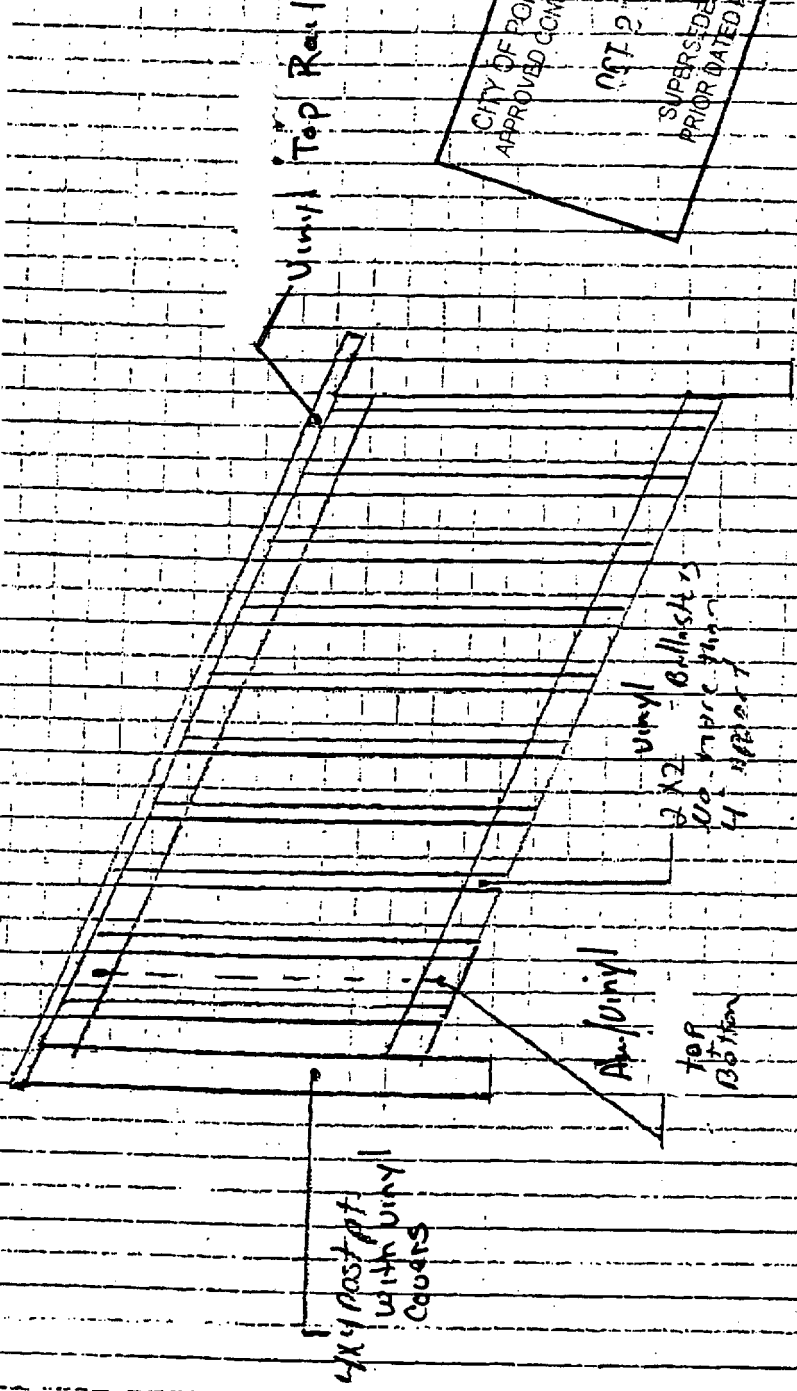

Steven Ryan

Dealer List Prices

THERMAL INDUSTRIES, INC.

Dream® Deck Railing System

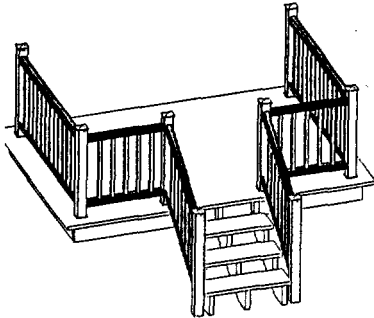

Notes:

#1; Masonry Hardware Kit attaches one railing section to masonry walls: 4-90° aluminum brackets; 4, 3/8" SS bolts & lock washers; 4, 3/8" anchors; 14, #10x1" hex head screws.

#2; Standard Dream Rail Hardware Kit attaches one railing section to 4x4 wood posts (same kit as included with Dream Rail 6' & 8' sections): 2-bottom rail brackets; 8, #9x2-1/2" Dacrotized deck screws; 6, #10x1" hex head screws.

#3; Optional Hardware Kit attaches one railing section to an existing wood column: 4-brackets; 8, #9x2-1/2" Dacrotized deck screws; 10, #10x1" hex head screws.

#4; Stair Hardware Kit for 36" or 42" Stair Packages; 3-angle brackets; 6, #9x2-1/2" Dacrotized deck screws; 6, #10x1" hex head screws.

DREAMSPACE
MIDWESTERN FLOORING

Dream® Deck and Dream® Dock

Manufactured by:
Thermal Industries, Inc.
Pittsburgh, PA 15221-2168
1-800-245-1540

Parts & Pieces

Dream" Deck 19 Sy

ITEM	DIMENSION	
Top Rail (with Aluminum Load)	73 3/16"	95 1/16"
Bottom Rail (with Aluminum Load)	70 7/16"	92 5/16"
ADA Grasp Rail (with Steel Load)	6' Section	8' Section
Post Cap	Standard	
Post Covers:	36"	4" x 4" x 49 7/8"
	42"	4" x 4" x 55 7/8"
Post Cover Kit	36"	Cover, Cap & Collar
	42"	Cover, Cap & Collar
Post Cover "H" Mullion	17' Section	
Post Collar	Fits 4" x 4" Wood Posts	
Pickets:	36"	1 1/2" x 1 1/2" x 27 1/8"
	42"	1 1/2" x 1 1/2" x 33 1/8"
Picket Spacer Caps:	6 Foot	69 7/16"
	8 Foot	91 3/16"
Galvanized Center Support Strap (Required)	36"	27 1/8"
	42"	33 1/8"
Masonry Post Attachment Hardware Kits	36"	One In-Line Post
	42"	One in-Line or Stair Post
Hardware Kits	36"	One Corner Post
	42"	One Corner Post
Rail Attachment, Masonry'	Hardware Kit For One rail Section	
Standard Hardware Kit²	For One Railing Section (6 or 8')	
Optional Hardware Kit³	For One Railing Section (6' or 8')	
Stairs Hardware Kit⁴	For One Railing Section (6 or 8')	
Simpson Strong Ties	Wood Post Braces	

Earthtone - Add 4%

General Information

- When ordering post covers, please specify the type: end, in-line, corner or 45°, and quantity of each type of cover required.
- Please refer to installation instructions.
- Stair railing orders must indicate type and location of posts: end, in-line or corner, top or bottom and left or right. Orientation is from bottom of steps looking up.

Pricing & Handling

- Prices are FOB Pittsburgh, PA.
- There is a \$60 charge on each shipment which is less than a full truck load (LTL).
- Prices are subject to change without notice.

6' and 8' Sections

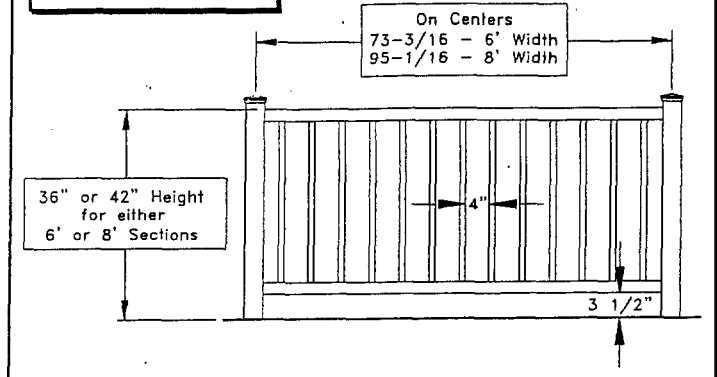

Options

Stair railing post covers will accommodate angles between 33° and 37°.

Dream® Deck Railings are available in additional colors. Please call.

For additional information please contact your local Thermal Industries, Inc. sales rep.

Dealer List Prices

THERMAL INDUSTRIES, INC.

Dream® Deck Railing System

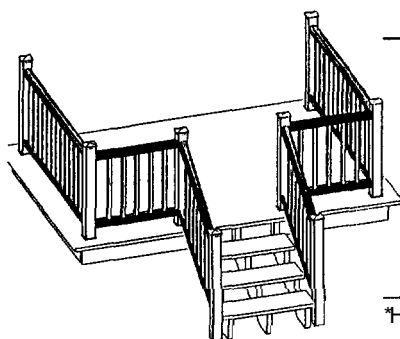

Dream® Deck Railing System - 42" Height

The Dream® Deck Premium Railing System is 100% extruded PVC. This product has been tested as exceeding specifications for Performance of Permanent Metal Railing Systems (ASTM E935-93). This exclusive system consists of PVC post covers for 4"x4" wood posts, PVC top and bottom rails featuring a banister design with internal aluminum reinforcement (load) for added strength, and 1 1/2" square heavy duty PVC pickets with snap-on spacer providing nominal 4" spacing for code compliance. A hardware kit is included with each railing section. Optional, pre-assembled Dream® Gates are available and can be hinged for either left or right operation. A thermal alloy, high-density hardware kit is included with each gate section.

Dealer List Pricing

42" HEIGHT White - Standard Earthtone - Add 4%	6 Foot Section 73 3/16" on centers	8 Foot section 95 1/16" on centers	QUANTITY
	COMPLETE SECTION	COMPLETE SECTION	
ITEM	DIMENSION	DIMENSION	----
Post Cover, Cap & Collar	-- --	-----	1 each
Top Rail	73 3/16"	95 1/16"	1
Bottom Rail	70 7/16"	92 5/16"	1
Pickets	1 1/2" x 1 1/2" x 33 1/8"	1 1/2" x 1 1/2" x 33 1/8"	12-6' & 16-8'
Picket Spacer Caps	69 7/16"	91 5/16"	2
Hardware Set*	-----	-----	1 Pack

*Hardware: 2, Bottom Rail Brackets; 8, #9 x 2-1/2" Dacrotized Deck Screws; 6, #10 x 1" Hex Head Screws; 1, Galvanized Center Support Strap.

Optional Dream® Gate Dealer List Pricing - 42" Standard Width Opening

White - Standard; Earthtone - Add 4%	42" Height
Pre-assembled Gate (With Hardware)	

Dream® Gate Parts

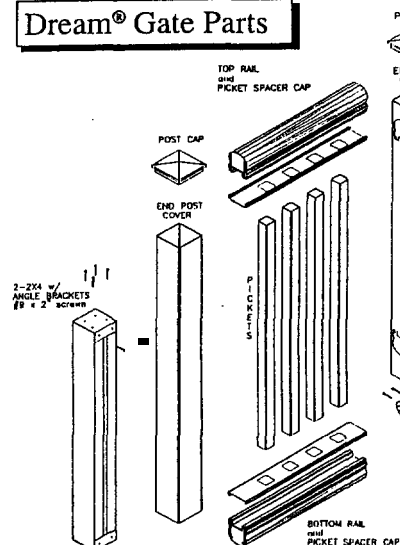

Dream® Rail Parts

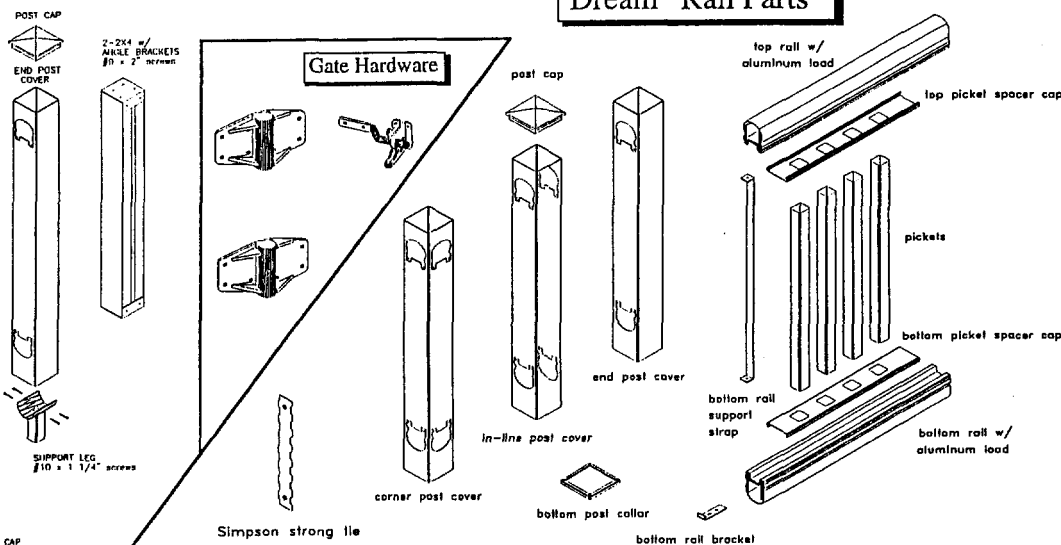

General Information

- * To complete a railing, an additional post cover may be required, depending upon the type of installation. This is NOT included in the above price. See 'Parts & Pieces' price page.
- When ordering post covers, please specify the type: end, in-line or corner, and quantity of each type of cover required.
- Stair railing orders must indicate type and location of posts: end, in-line or corner, 45°, top or bottom and left or right. Orientation is from bottom of steps locking up.
- Please refer to installation instructions.

Pricing & Handling

- * Earthtone - add 4%
- Prices are FOB Pittsburgh, PA.
- There is a \$60 charge on each shipment which is less than a full truck load (LTL).
- Prices are subject to change without notice.

Options

Stair railing post cover angles are between 33° and 37°. A wood post brace (two Simpson Strong Tie brackets and screws) may be required at a cost of \$5.00 each.

Post and Railing attachment hardware to concrete and masonry is available. See Dream@Deck® "Parts/Pieces" pricing.

An American Disabilities Act (ADA) approved grasp rail is available. See Dream® Deck "Parts/Pieces" pricing.

For additional information please contact your local Thermal Industries, Inc. sales rep.

DREAMSPACE®
Maintenance-Free
Dream® Deck and Dream. Dock
Manufactured by:
Thermal Industries, Inc.
Pittsburgh, PA 15221-2168
1-800-245-1540