

DISPLAY THIS CARD ON PRINCIPAL FRONTAGE OF WORK CITY OF PORTLAND

Please Read Application And Notes, If Any, Attached

BUILDING PERMIT

PERMIT ISSUED
Permit Number: 100406
MAY 19 2010
CITY OF PORTLAND

This is to certify that MEADER ROBERT & PAMELA JTS / Architects & Engineers

has permission to Build a 10' x 10' deck replace window with slider

AT 151 SUMMIT ST City - 396 C012001

provided that the person or persons, firm or corporation accepting this permit shall comply with all of the provisions of the Statutes of Maine and of the Ordinances of the City of Portland regulating the construction, maintenance and use of buildings and structures, and of the application on file in this department.

Apply to Public Works for street line and grade if nature of work requires such information.

Notification of inspection must be given and written permission procured before this building or part thereof is lathed or otherwise dressed-in. 24 HOUR NOTICE IS REQUIRED.

A certificate of occupancy must be procured by owner before this building or part thereof is occupied.

OTHER REQUIRED APPROVALS

- Fire Dept. _____
- Health Dept. _____
- Appeal Board _____
- Other _____
Department Name

Director - Building & Inspection Services

PENALTY FOR REMOVING THIS CARD

City of Portland, Maine - Building or Use Permit Application
 389 Congress Street, 04101 Tel: (207) 874-8703, Fax: (207) 874-8716

Permit No: 10-0406	Issue Date:	CBL: 396 C012001
-----------------------	-------------	---------------------

Location of Construction: 151 SUMMIT ST	Owner Name: MEADER ROBERT & PAMELA J	Owner Address: 151 SUMMIT ST	Phone:
Business Name:	Contractor Name: Affordable Kitchens & Baths	Contractor Address: 28 Elm Street Biddeford	Phone: 2072860600
Lessee/Buyer's Name	Phone:	Permit Type: Additions - Dwellings	Zone: R2

Past Use: Single Family Home	Proposed Use: Single Family Home - Build a 10' x 10' deck replace window with 8 ft slider	Permit Fee: \$70.00	Cost of Work: \$4,400.00	CEO District: 5
Proposed Project Description: Build a 10' x 10' deck replace window with 8ft slider		FIRE DEPT: <input type="checkbox"/> Approved <input type="checkbox"/> Denied <i>[Signature]</i>	INSPECTION: Use Group: R-3 Type: EB <i>IRC 2003</i> <i>[Signature]</i>	
		PEDESTRIAN ACTIVITIES DISTRICT (P.A.D.) Action: <input type="checkbox"/> Approved <input type="checkbox"/> Approved w/Conditions <input type="checkbox"/> Denied Signature: _____ Date: _____		

Permit Taken By: Idobson	Date Applied For: 04/23/2010	Zoning Approval		
-----------------------------	---------------------------------	------------------------	--	--

1. This permit application does not preclude the Applicant(s) from meeting applicable State and Federal Rules. 2. Building permits do not include plumbing, septic or electrical work. 3. Building permits are void if work is not started within six (6) months of the date of issuance. False information may invalidate a building permit and stop all work..	Special Zone or Reviews <input type="checkbox"/> Shoreland <input type="checkbox"/> Wetland <input type="checkbox"/> Flood Zone <input type="checkbox"/> Subdivision <input type="checkbox"/> Site Plan Maj <input type="checkbox"/> Minor <input type="checkbox"/> MM <input type="checkbox"/> OK w/conditions Date: 4/23/10 <i>ABM</i>	Zoning Appeal <input type="checkbox"/> Variance <input type="checkbox"/> Miscellaneous <input type="checkbox"/> Conditional Use <input type="checkbox"/> Interpretation <input type="checkbox"/> Approved <input type="checkbox"/> Denied Date: _____	Historic Preservation <input checked="" type="checkbox"/> Not in District or Landmark <input type="checkbox"/> Does Not Require Review <input type="checkbox"/> Requires Review <input type="checkbox"/> Approved <input type="checkbox"/> Approved w/Conditions <input type="checkbox"/> Denied Date: <i>ABM</i>
--	--	--	--

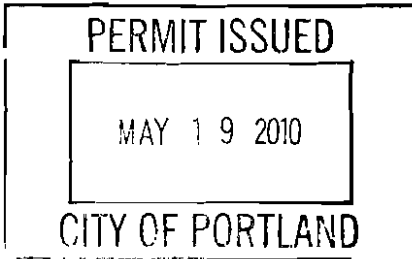

CERTIFICATION

I hereby certify that I am the owner of record of the named property, or that the proposed work is authorized by the owner of record and that I have been authorized by the owner to make this application as his authorized agent and I agree to conform to all applicable laws of this jurisdiction. In addition, if a permit for work described in the application is issued, I certify that the code official's authorized representative shall have the authority to enter all areas covered by such permit at any reasonable hour to enforce the provision of the code(s) applicable to such permit.

SIGNATURE OF APPLICANT	ADDRESS	DATE	PHONE
RESPONSIBLE PERSON IN CHARGE OF WORK, TITLE		DATE	PHONE

City of Portland, Maine - Building or Use Permit

389 Congress Street, 04101 Tel: (207) 874-8703, Fax: (207) 874-8716

Permit No: 10-0406	Date Applied For: 04/23/2010	CBL: 396 C012001
------------------------------	--	----------------------------

Location of Construction: 151 SUMMIT ST	Owner Name: MEADER ROBERT & PAMELA J	Owner Address: 151 SUMMIT ST	Phone:
Business Name:	Contractor Name: Affordable Kitchens & Baths	Contractor Address: 28 Elm Street Biddeford	Phone (207) 286-0600
Lessee/Buyer's Name	Phone:	Permit Type: Additions - Dwellings	

Proposed Use: Single Family Home - Build a 10' x 10' deck & replace window with 8 ft slider	Proposed Project Description: Build a 10' x 10' deck & replace window with 8ft slider
---	---

Dept: Zoning **Status:** Approved with Conditions **Reviewer:** Ann Machado **Approval Date:** 04/23/2010

Note: **Ok to Issue:** ✓

- 1) This property shall remain a single family dwelling. Any change of use shall require a separate permit application for review and approval.
- 2) This permit is being approved on the basis of plans submitted. Any deviations shall require a separate approval before starting that work.

Dept: Building **Status:** Approved with Conditions **Reviewer:** Tammy Munson **Approval Date:** 05/17/2010

Note: **Ok to Issue:** ✓

- 1) Separate permits are required for any electrical, plumbing, sprinkler, fire alarm HVAC systems, heating appliances, commercial hood exhaust systems and fuel tanks. Separate plans may need to be submitted for approval as a part of this process.
- 2) Application approval based upon information provided by applicant. Any deviation from approved plans requires separate review and approval prior to work.

BUILDING PERMIT INSPECTION PROCEDURES

Please call 874-8703 or 874-8693 (ONLY)

or email: buildinginspections@portlandmaine.gov

With the issuance of this permit, the owner, builder or their designee is required to provide adequate notice to the City of Portland Inspection Services for the following inspections. Appointments must be requested 48 to 72 hours in advance of the required inspection. The inspection date will need to be confirmed by this office.

- **Please read the conditions of approval that is attached to this permit!! Contact this office if you have any questions.**
- **Permits expire in 6 months, if the project is not started or ceases for 6 months.**
- **If the inspection requirements are not followed as stated below additional fees may be incurred due to the issuance of a "Stop Work Order" and subsequent release to continue with construction.**

 X **Footing/Building Location Inspection: Prior to pouring concrete or setting precast piers**

 X **Framing/Rough Plumbing/Electrical: Prior to Any Insulating or drywalling**

 X **Final inspection required at completion of work.**

The project cannot move to the next phase prior to the required inspection and approval to continue, REGARDLESS OF THE NOTICE OR CIRCUMSTANCES.

IF THE PERMIT REQUIRES A CERTIFICATE OF OCCUPANCY, IT MUST BE PAID FOR AND ISSUED TO THE OWNER OR DESIGNEE BEFORE THE SPACE MAY BE OCCUPIED.



CITY OF PORTLAND, MAINE

Department of Building Inspections

Original Receipt

4.23 2010

Received from

Pamela Meade

Location of Work

151 Summit St

Cost of Construction

\$

Building Fee:

Permit Fee

\$

Site Fee:

Certificate of Occupancy Fee:

Total:

70

Building (B)

Plumbing (P)

Electrical (E)

Site Plan (U)

Other

CBL:

396-C-12

Check #:

2642

Total Collected \$

70

**No work is to be started until permit issued.
Please keep original receipt for your records.**

Taken by:

[Signature]

WHITE - Applicant's Copy
YELLOW - Office Copy
PINK - Permit Copy



General Building Permit Application

If you or the property owner owes real estate or personal property taxes or user charges on any property within the City, payment arrangements must be made before permits of any kind are accepted.

Location/Address of Construction: <u>151 Summit Street</u>		
Total Square Footage of Proposed Structure/Area: <u>100ft²</u>		Square Footage of Lot: <u>20,119ft²</u>
Tax Assessor's Chart, Block & Lot Chart# <u>396</u> Block# <u>C</u> Lot# <u>12</u> <u>(Attached)</u>	Applicant <u>must be owner, Lessee or Buyer</u> Name <u>Robert Meador</u> Address <u>151 Summit St</u> City, State & Zip <u>Portland, Me 04103</u>	Telephone: <u>878-2832</u>
Lessee/DBA (If Applicable)	Owner (if different from Applicant) Name Address City, State & Zip	Cost Of Work: \$ <u>4400</u> C of O Fee: \$ Total Fee: \$ <u>70</u>
Current legal use (i.e. single family) <u>Single family</u> If vacant, what was the previous use? Proposed Specific use: <u>deck</u> Is property part of a subdivision? <u>no</u> If yes, please name Project description: <u>Build a 10x10ft deck and m-stair replace window with 8ft slider + 2x10' header</u>		
Contractor's name: <u>Attydeke Kitchen: 3rd Construction</u> Address: <u>Beggs St (Rte 1) 428 Edgemoor St</u> City, State & Zip: <u>Baldwin, Me</u> Telephone: <u>286-0600</u> Who should we contact when the permit is ready: <u>Robert Meador</u> Telephone: <u>838-9457 (cell)</u> Mailing address: <u>151 Summit St, Portland, Me 04103</u>		

Please submit all of the information outlined on the applicable Checklist. Failure to do so will result in the automatic denial of your permit.

In order to be sure the City fully understands the full scope of the project, the Planning and Development Department may request additional information prior to the issuance of a permit. For further information or to download copies of this form and other applications visit the Inspections Division on-line at www.portlandmaine.gov, or stop by the Inspections Division office, room 315 City Hall or call 874-8703.

I hereby certify that I am the Owner of record of the named property, or that the owner of record authorizes the proposed work and that I have been authorized by the owner to make this application as his/her authorized agent. I agree to conform to all applicable laws of this jurisdiction. In addition, if a permit for work described in this application is issued, I certify that the Code Officer's authorized representative shall have the authority to enter all areas covered by this permit at any reasonable hour to enforce the provisions of the codes applicable to this permit.

Signature: Robert Meador Date: 4/20/2010

This is not a permit; you may not commence ANY work until the permit is issued

RECEIVED

APR 23 2010
Dept. of Building Inspections
City of Portland Maine

OLD BIRCH LANE

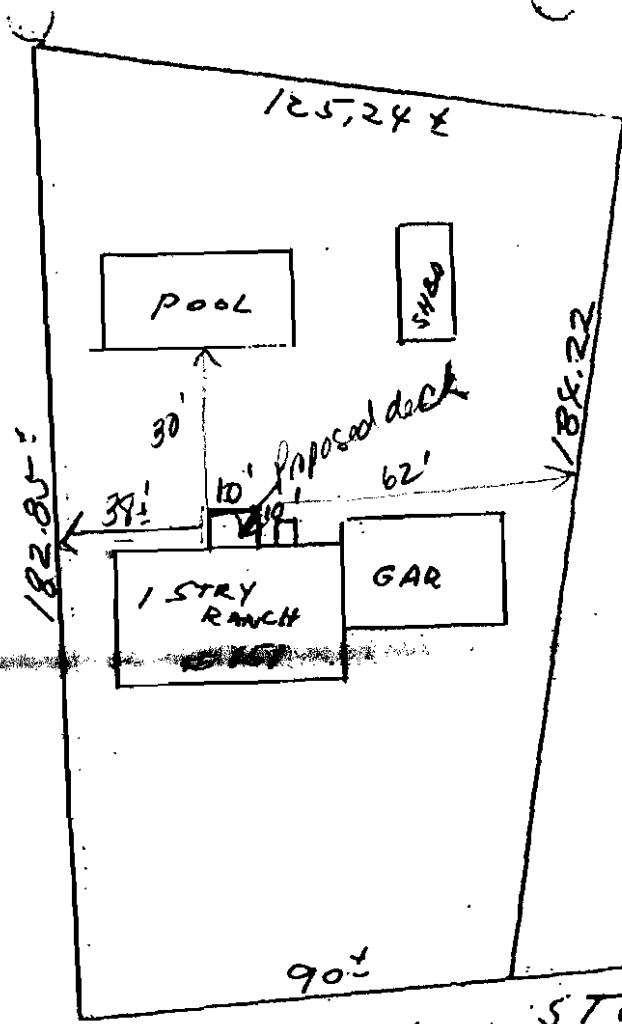

R-2

lot size - 20,119
 front setback - N/A
 rear " - 25' - 30' to pool (OK)
 side yard - 15' by 12' - 60' in depth
 side setback - 20' - 38' min

lot coverage - ~~20%~~ 20% = 4023 sq ft

existing - 1422 2126
 shed - 288
 2414
 proposed 130
 2544 (OK)

SUMMIT STREET

AFFORDABLE KITCHENS & BATHS
428 ELM ST/ROUTE 1
BIDDEFORD MAINE 04005
PH- (207) 286-0600
FAX(207) 286-1900

~~FAX~~ COVER SHEET

TO: code Enforcement

FROM: JSC

COMPANY: Portland, ME

DATE: 4/7/10

FAX NUMBER:

TOTAL # OF PGS

PHONE NUMBER:

NOTES/COMMENTS:

X (-Stair railing)

I have you for your bid for the
Deck Permit. I will probably install
a stair railing even though it is less
than 4 runs. As discuss I will place a
stair railing attached to the side of the 5/4 x
deck brackets are not used until its released
to the 5/4 x 6's

1. 2. 3. 4. 5. 6. 7. 8. 9. 10. 11. 12. 13. 14. 15. 16. 17. 18. 19. 20. 21. 22. 23. 24. 25. 26. 27. 28. 29. 30. 31. 32. 33. 34. 35. 36. 37. 38. 39. 40. 41. 42. 43. 44. 45. 46. 47. 48. 49. 50. 51. 52. 53. 54. 55. 56. 57. 58. 59. 60. 61. 62. 63. 64. 65. 66. 67. 68. 69. 70. 71. 72. 73. 74. 75. 76. 77. 78. 79. 80. 81. 82. 83. 84. 85. 86. 87. 88. 89. 90. 91. 92. 93. 94. 95. 96. 97. 98. 99. 100.

BUILDING A DECK????

INFORMATION REQUIRED WITH YOUR APPLICATION

The following is a guideline of information required for the review of a deck application. It is intended to help you supply proper and complete application packages. Please label all of the following items on your plans. Thank you!

1. **A complete plot plan showing all structures and proposed structures with distances to all property lines labeled.** (we have done this)
2. **Type of foundation system**
 - a. Diameter of concrete filled tube or pre cast concrete pier size - # 3
 - b. Depth below grade (minimum 4'-0" below grade) - # 3
 - c. Anchorage of column to footing - *3" x 3" footing with 4" x 4" anchor bolts*
 - d. Spacing and location of tubes/piers - # 3
3. **Framing Members**
 - a. Columns - wood size and location (members supporting framing of floor system) - # 3 *4" x 4" on 1'*
 - b. Ledger size attached to building - # 2
 - c. Fastener size and spacing attaching ledger - # 2
 - d. Girder size and spans carrying floor system - # 2
 - e. Joist size, span, and spacing - # 5
 - f. Joist hangers or ledger - # 5
4. **Guardrails and handrail details**
 - a. Guardrail height - *36"*
 - b. Baluster spacing - *42" max*
 - c. Handrail height - *40"*
5. **Stair Details**
 - a. Tread depth (measured nosing to nosing) - *11"*
 - b. Riser height - *7 1/2"*
 - c. Nosing on tread - *1"*
 - d. Width of stairs - *45"*

from 20'



2" x 10" HEADER
w/ 1/2" plywood
SHEATH



2" x 10" HEADER

6" x 6" SILL

SLIDING PLATE

1" x 4" SILL

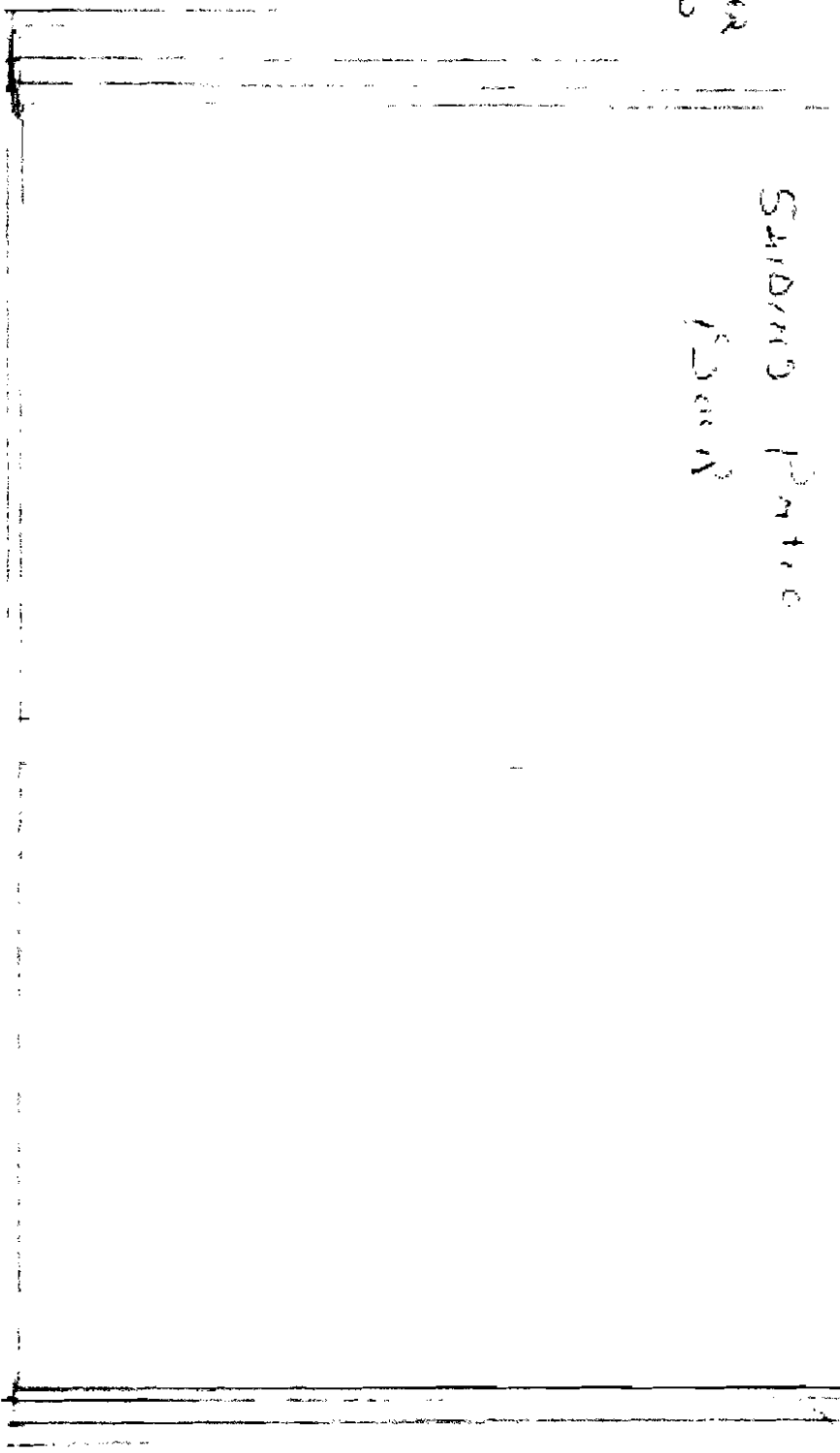

2" x 4" SILL
2" x 4" SILL

11' x 11' 1/2" x 11' 1/2"

151 Sacramento St

Portland, OR

Chickadee Park + 30th

432 6th St

Building Dept, no. 01005

1-200-980-1000

* 10 N10 L-Beam
 M. Scales Home
 151 Summit St
 Portland, ME

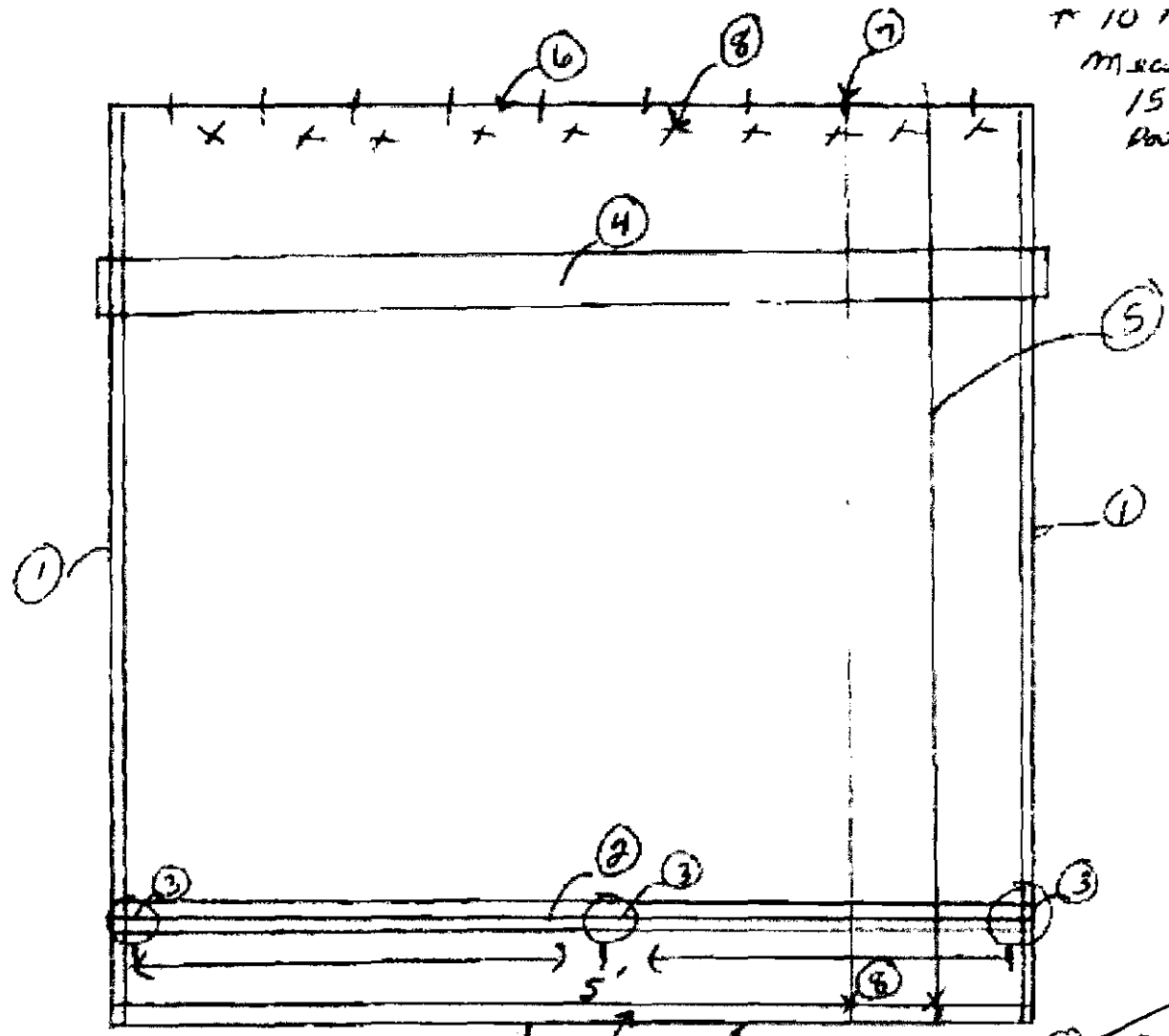

* RAILINGS

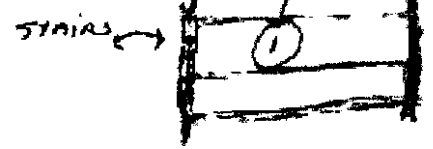
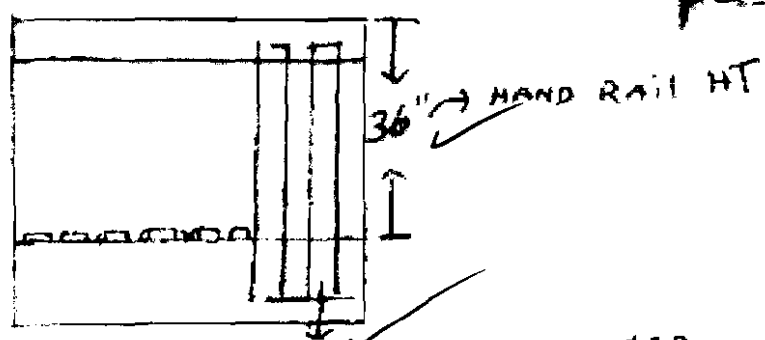

- ① - Double 2x8
- ② - ③ 2x8 for
 casing beam
 GR
- ③ 10" non-slip
 4" in top
 ground
- ④ 5/4 x 6 Deck
 planks (PT)
- ⑤ 2x8 x 10" 10'-0"
 16" on center
- ⑥ 2x8 ledger
- ⑦ 3/8 lag bolts
 16" 4'-apart
- ⑧ joist hangers

* Stairs

- ① steps - 11" wide (depth)
- ② RISES - 7 1/4"
- ③ 48" - width of stairs - (center of front)

65 Affordable Kitchens + Baths
 428 Elm St
 Biddeford, ME 04005 907-286-0600

Assessor's Office | 359 Congress Street | Portland, Maine 04101 | Room 115 | (207) 674-8486

City Home Departments City Council E Services Calendar Jobs

This page contains a detailed description of the Parcel ID you selected. Press the **New Search** button at the bottom of the screen to submit a new query.

Current Owner Information:

Services

Applications

Doing Business

Maps

Tax Relief

Tax Roll

Q & A

CBL 396 C012001
Land Use Type SINGLE FAMILY
Property Location 151 SUMMIT ST
Owner Information MEADER ROBERT & PAMELA JTS
 151 SUMMIT ST
 PORTLAND ME 04103
Book and Page
Legal Description 396-C-12
 SUMMIT ST 151
 OLD BIRCH LANE 1-15
 20119 SF
Acres 0.482

Current Assessed Valuation:

browse city services a-z

browse facts and links a-z

TAX ACCT NO. 40666 **OWNER OF RECORD AS OF APRIL 2009**
 MEADER ROBERT & PAMELA JTS
LAND VALUE \$94,600.00 151 SUMMIT ST
BUILDING VALUE \$135,600.00 PORTLAND ME 04103
NONRESIDENT EXEMPTION (\$12,350.00)
NET TAXABLE - REAL ESTATE \$217,850.00
TAX AMOUNT \$3,864.66

Any information concerning tax payments should be directed to the Treasury office at 874-8490 or [e-mailed](mailto:).

Building Information:



Best viewed at 800x600, with Internet Explorer

Card 1 of 1
Year Built 1964
Style/Structure Type RANCH
Stories 1
Bedrooms 3
Full Baths 1
Half Baths 1
Total Rooms 7
AHJc NONE
Basement FULL
Square Feet 1510

[View Sketch](#) [View Map](#) [View Picture](#)



Outbuildings/Yard Improvements:

Card 1
Year Built 1980
Structure POOL-PREFAB PLASTIC LINER
Size 20X40
Units 1
Grade C
Condition A

Card 1
Year Built 1980
Structure SHED-FRAME
Size 12X24
Units 1
Grade C
Condition A



7-6-10

class - completed



CITY OF PORTLAND, MAINE

Department of Building Inspections

Original Receipt

9/25 2010

Received from Pamela Miller

Location of Work 151- Sun St

Cost of Construction \$ _____ Building Fee: _____

Permit Fee \$ _____ Site Fee: _____

Certificate of Occupancy Fee: _____

Total: 70

Building (1L) _____ Plumbing (1S) _____ Electrical (12) _____ Site Plan (U2) _____

Other _____

CBL: 396-C-12

Check #: 2642 Total Collected \$ 70

**No work is to be started until permit issued.
Please keep original receipt for your records.**

Taken by: [Signature]

WHITE - Applicant's Copy
YELLOW - Office Copy
PINK - Permit Copy