

**City of Portland, Maine - Building or Use Permit Application**

389 Congress Street, 04101 Tel: (207) 874-8703, Fax: (207) 874-8716

<b>PERMIT ISSUED</b>		
Permit No: 05-0995	Issue Date: AUG 11 2005	CBL: 390 A009001
Owner Address: 26 Quiet Ln	Phone:	
Contractor Address: 515 Riverside Industrial Parkw Portlan	Phone: 2078786600	
Permit Type: HVAC	Zone:	
Permit Fee: \$39.00	Cost of Work: \$1,220.00	CEO District: 5
FIRE DEPT: <input type="checkbox"/> Approved <input type="checkbox"/> Denied <i>N/A</i>	INSPECTION: Use Group: <i>R-3/0</i> Type: <i>Heating</i> <i>State Gas Regs</i>	
Signature:	Signature:	
PEDESTRIAN ACTIVITIES DISTRICT (P.A.D.)		
Action: <input type="checkbox"/> Approved <input type="checkbox"/> Approved w/Conditions <input type="checkbox"/> Denied		
Signature:		Date:

Location of Construction: 108 Hope Ave	Owner Name: Flaherty Richard J
Business Name:	Contractor Name: Builders Insulation
Lessee/Buyer's Name	Phone:
Past Use: Single Family Home	Proposed Use: Single Family Home/ install a FMI direct vent gas
Proposed Project Description: Install a FMI direct vent gas	

Permit Taken By: Idobson	Date Applied For: 07/15/2005	<b>Zoning Approval</b>
-----------------------------	---------------------------------	------------------------

<ol style="list-style-type: none"> <li>This permit application does not preclude the Applicant(s) from meeting applicable State and Federal Rules.</li> <li>Building permits do not include plumbing, septic or electrical work.</li> <li>Building permits are void if work is not started within six (6) months of the date of issuance. False information may invalidate a building permit and stop all work..</li> </ol>	<b>Special Zone or Reviews</b> <input type="checkbox"/> Shoreland <input type="checkbox"/> Wetland <input type="checkbox"/> Flood Zone <input type="checkbox"/> Subdivision <input type="checkbox"/> Site Plan Maj <input type="checkbox"/> Minor <input type="checkbox"/> MM <input type="checkbox"/> Date: <i>8/2/05</i>	<b>Zoning Appeal</b> <input type="checkbox"/> Variance <input checked="" type="checkbox"/> Miscellaneous <input type="checkbox"/> Conditional Use <input type="checkbox"/> Interpretation <input type="checkbox"/> Approved <input type="checkbox"/> Denied Date:	<b>Historic Preservation</b> <input checked="" type="checkbox"/> Not in District or Landmark <input type="checkbox"/> Does Not Require Review <input type="checkbox"/> Requires Review <input type="checkbox"/> Approved <input type="checkbox"/> Approved w/Conditions <input type="checkbox"/> Denied Date: <i>8/2/05</i>
---	---	--	--

**CERTIFICATION**

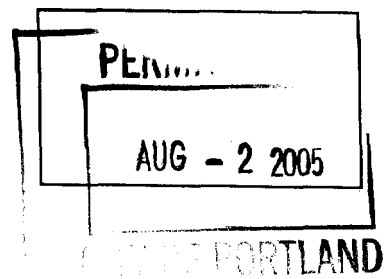
I hereby certify that I am the owner of record of the named property, or that the proposed work is authorized by the owner of record and that I have been authorized by the owner to make this application as his authorized agent and I agree to conform to all applicable laws of this jurisdiction. In addition, if a permit for work described in the application is issued, I certify that the code official's authorized representative shall have the authority to enter **all** areas covered by such permit at any reasonable hour to enforce the provision of the code(s) applicable to such permit.

SIGNATURE OF APPLICANT	ADDRESS	DATE	PHONE
RESPONSIBLE PERSON IN CHARGE OF WORK, TITLE		DATE	PHONE



FILL IN AND SIGN WITH INK

# APPLICATION FOR PERMIT HEATING OR POWER EQUIPMENT



To the **INSPECTOR OF BUILDINGS, PORTLAND, ME.**

The undersigned hereby applies for a permit to install the following heating, cooking or power equipment in accordance with the **Laws of Maine, the Building Code of the City of Portland, and the following specifications:**

Location / CBL 108 Hope Ave Use of Building Home Date \_\_\_\_\_  
Name and address of owner of appliance Blue Horizons development Auburn

Installer's name and address Builders Insulation of Maine  
515 Riverside Ind. Pkwy Telephone 878-6600

**Location of appliance:**  
 Basement       Floor  
 Attic             Roof

**Type of Fuel:**  
 Gas       Oil       Solid

**Appliance Name:** FMI Direct vent F/R  
 U.L. Approved  Yes  No

Will appliance be installed in accordance with the manufacture's installation instructions?  Yes       No

IF NO Explain: \_\_\_\_\_

**The Type of License of Installer:**

Master Plumber # \_\_\_\_\_  
 Solid Fuel # \_\_\_\_\_  
 Oil # \_\_\_\_\_  
 Gas # PNT 3025  
 Other \_\_\_\_\_

**Type of Chimney:**  
 Masonry Lined  
 Factory built \_\_\_\_\_

Metal  
 Factory Built U.L. Listing # \_\_\_\_\_

Direct Vent  
 Type Horizontal UL# \_\_\_\_\_

**Type of Fuel Tank**  
 Oil  
 Gas

Size of Tank N/A

Number of Tanks N/A

Distance from Tank to Center of Flame N/A feet.

Cost of Work: \$ 1220

Permit Fee: \$ 3900

Approved

Approved with Conditions

Fire: \_\_\_\_\_  
Ele.: \_\_\_\_\_  
Bldg.: \_\_\_\_\_

See attached letter or requirement

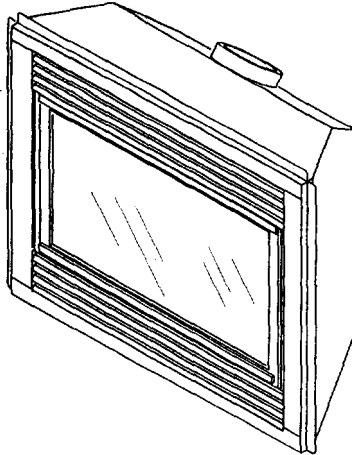
\_\_\_\_\_  
Inspector's Signature      Date Approved

Signature of Installer William Ruis



# DIRECT-VENT FIREPLACE OWNER'S OPERATION AND INSTALLATION MANUAL

For more information, visit [www.desatech.com](http://www.desatech.com)



## NATURAL GAS MODELS CHDV36NRA AND (V)V36NA(1) SERIES PROPANE/LP GAS MODEL (V)V36PA(1) SERIES

**WARNING:** If the information in this manual is not followed exactly, a fire or explosion may result causing property damage, personal injury, or loss of life.

### FOR YOUR SAFETY

Do not store or use gasoline or other flammable vapors and liquids in the vicinity of this or any other appliance.

### FOR YOUR SAFETY

#### WHAT TO DO IF YOU SMELL GAS

- Do not try to light any appliance.
- Do not touch any electrical switch
- Do not use any phone in your building.
- Immediately call your gas supplier from a neighbor's phone. Follow the gas supplier's instructions.
- If you cannot reach your gas supplier, call the fire department.

**WARNING:** Improper installation, adjustment, alteration, service, or maintenance can cause injury or property damage. Refer to this manual for correct installation and operational procedures. For assistance or additional information consult a qualified installer, service agency, or the gas supplier.

**Installation and service must be performed by a qualified installer, service agency, or the gas supplier.**

This appliance may be installed in an **aftermarket\***, permanently located, manufactured (mobile) home, where not prohibited by state or local codes.

This appliance is only for use with the type of gas indicated on the rating plate. This appliance is not convertible for use with other gases, unless a certified kit is used.

\*Aftermarket: Completion of sale, not for purpose of resale, from the manufacturer.

Save this manual for future reference.



## TABLE OF CONTENTS

SAFETY INFORMATION .....	2	CLEANING AND MAINTENANCE .....	28
PRODUCT IDENTIFICATION .....	3	TROUBLESHOOTING .....	29
LOCAL CODES .....	3	ILLUSTRATED PARTS BREAKDOWN AND PARTS LIST .....	32
PRODUCT FEATURES .....	4	REPLACEMENT PARTS .....	36
PRE-INSTALLATION PREPARATION .....	4	SPECIFICATIONS .....	36
LOCATION OF TERMINATION CAP .....	6	SERVICE HINTS .....	36
VENTING INSTALLATION INSTRUCTIONS .....	7	TECHNICAL SERVICE .....	36
FIREPLACE INSTALLATION .....	17	OWNER'S REGISTRATION FORM .....	37
OPERATING FIREPLACE .....	25	ACCESSORIES .....	39
INSPECTING BURNERS .....	27	WARRANTY INFORMATION .....	Back Cover

## SAFETY INFORMATION



### WARNINGS

**WARNING:** This product contains and/or generates chemicals known to the State of California to cause cancer or birth defects, or other reproductive harm.

**IMPORTANT:** Read this owner's manual carefully and completely before trying to assemble, operate, or service this fireplace. Improper use of this fireplace can cause serious injury or death from burns, fire, explosions, electrical shock, and carbon monoxide poisoning.

**DANGER:** Carbon monoxide poisoning may lead to death!

Natural and Propane/LP Gas: Natural and propane/LP gases are odorless. An odor-making agent is added to the gas. The odor helps you detect a gas leak. However, the odor added to the gas can fade. Gas may be present even though no odor exists.

Make certain you read and understand all warnings. Keep this manual for reference. It is your guide to safe and proper operation of this fireplace.



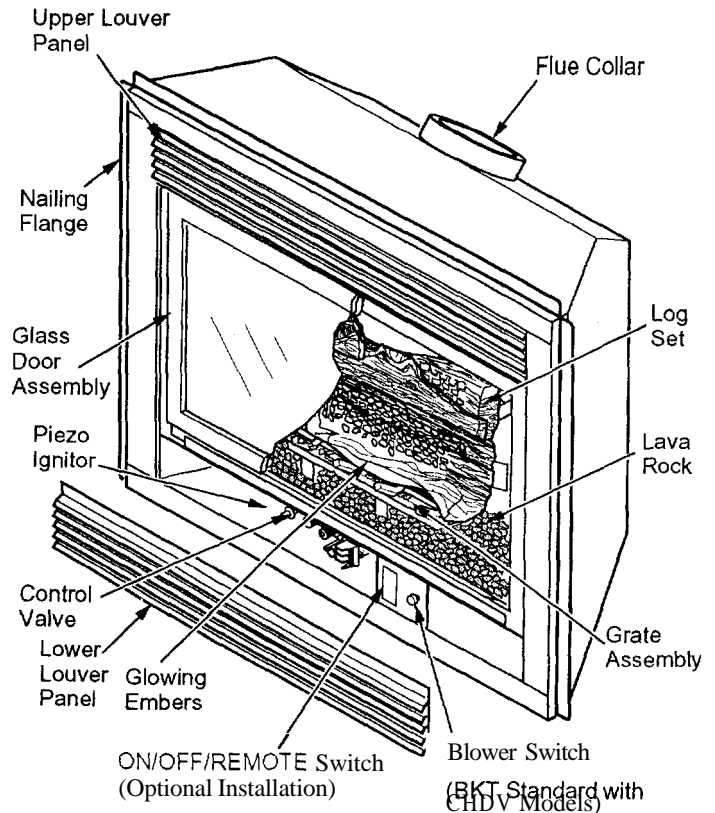
**WARNING:** Any change to this fireplace or its controls can be dangerous.

1. This appliance is only for use with the type of gas indicated on the rating plate. This appliance is not convertible for use with other gases unless a certified kit is used.
2. For propane/LP fireplace, do not place propane/LP supply tank(s) inside any structure. Locate propane/LP supply tank(s) outdoors. To prevent performance problems, do not use pro-

## SAFETY INFORMATION *Continued*

5. This fireplace reaches high temperatures. Keep children and adults away from hot surfaces to avoid burns or clothing ignition. Fireplace will remain hot for a time after shutdown. Allow surfaces to cool before touching.
6. Carefully supervise young children when they are in the room with fireplace.
7. Do not modify this fireplace under any circumstances. **Any** parts removed for servicing must be replaced prior to operating fireplace.
8. Turn fireplace off and let cool before servicing, installing, or repairing. Only a qualified service person should install, service, or repair **this** fireplace. Have fireplace inspected annually by a qualified service person.
9. You must keep control compartments, burners, and circulating air passages clean. More frequent cleaning may be needed due to excessive lint and dust from carpeting, bedding material, etc. Turn off the gas valve and pilot light before cleaning fireplace.
10. Have venting system inspected annually by a qualified service person. If needed, have venting system cleaned or repaired. See *Cleaning and Maintenance*, page 28.
11. Keep the area around your fireplace clear of combustible materials, gasoline, and other flammable vapor and liquids. Do not run fireplace where these are used or stored. Do not place items such as clothing or decorations on or around fireplace.
12. Do not use this fireplace to cook food or bum paper or other objects.
13. Do not use **any** solid fuels (wood, coal, paper, cardboard, etc.) in this fireplace. Use only the gas type indicated on fireplace nameplate.
14. This appliance, when installed, must be electrically grounded in accordance with local codes or, in the absence of local codes, with the *National Electrical Code, ANSI/NFPA 70*, or the *Canadian Electrical Code, CSA C22.1*.
15. Do not use fireplace if any part has been exposed to or under water. Immediately call a qualified service person to arrange for replacement of the unit.
16. Do not operate fireplace if any log is broken.
17. Do not use a blower insert, heat exchanger insert, or other accessory not approved for use with this fireplace.
18. Do not operate fireplace with glass door removed, cracked, or broken.
19. Provide adequate clearances around air openings.

## PRODUCT IDENTIFICATION



**Figure 1 - Direct-Vent Fireplace with Millivolt Ignition**

## LOCAL CODES

Install and use fireplace with care. Follow all local codes. In the absence of local codes, use the current *National Fuel Gas Code ANSI Z223.1/NFPA 54\** (USA) or the current *CSA-R149.1 Installation Code* (Canada).

\*Available from:

American National Standards Institute, Inc.  
1430 Broadway  
New York, NY 10018  
National Fire Protection Association, Inc.  
Batterymarch Park  
Quincy, MA 02269

## PRODUCT FEATURES

These are a few facts that can help you understand and enjoy your direct-vent fireplace:

- The venting system may be routed to the outside of your home in several ways. It may vent through the roof (vertical) or it may vent to an outside/exterior wall (horizontal). The vent pipe installation is very important to allow for proper operation. You must follow the venting instructions very carefully for either vertical or horizontal applications.
- This fireplace may be installed in any room of your house provided all local codes and these installation instructions are followed.
- This fireplace requires a wall switch, hand-held remote or wall thermostat (millivolt) for operation (see *Accessories*, page 39).
- This fireplace does not require electricity to operate.
- Only the blower requires electricity if installed and if you plan to install the blower at a later date, do not forget to wire the outlet at the bottom of the fireplace when framing.
- A piezo ignitor and ceramic electrode create spark to ignite the pilot light. It does not require any matches, batteries or any other sources of ignition to light the pilot.
- Each time you turn on your fireplace, you may notice some amount of condensation on the inside of the fireplace glass. This is normal and will disappear after 10-20 minutes of operation.
- Your direct-vent gas fireplace system (fireplace and venting) is a balanced and sealed gas operating unit. It requires approximately 10-20 minutes of operating time before the flame pattern stabilizes.
- Your fireplace is designed to be used in zero clearance installations. Wall or framing material can be placed directly against any exterior surface on the back, sides, or top of your fireplace, except where standoff spacers are integrally attached. If standoff spacers are attached to your fireplace, these spacers can be placed directly against wall or framing material. See framing details on page 5.
- If you plan on installing a television or entertainment center recessed above your fireplace, it is recommended that you maintain a minimum 18" above top of louver opening.
- When locating termination cap, it is important to observe the minimum clearances shown in Figure 7, page 6.
- If recessing into a wall, you can avoid extra framing by positioning your fireplace against an already existing framing member.
- Do not recess termination cap into a wall or siding.
- You may paint the termination cap with 450°F (232°C) heat-resistant paint to coordinate with the exterior finish.
- There must not be any obstruction such as bushes, garden sheds, fences, decks, or utility buildings within 24" from the front of the termination cap.
- Do not locate termination cap where excessive snow or ice build up may occur. Be sure to clear vent termination area after snow falls to prevent accidental blockage of venting system. When using snow blowers, do not direct snow towards vent termination area.

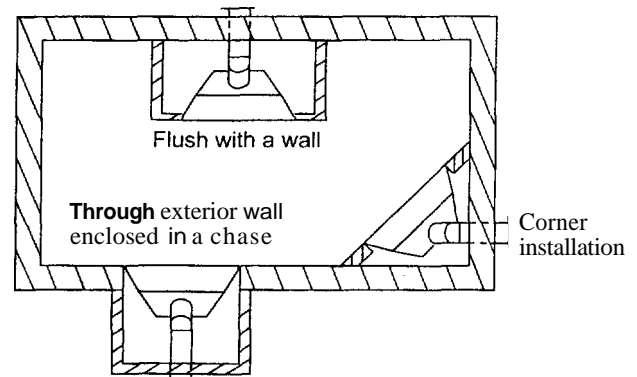
## PRE-INSTALLATION PREPARATION

### LOCATION AND SPACE REQUIREMENTS

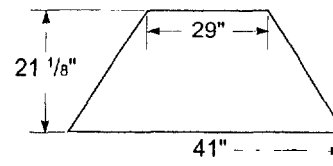
Determine the safest and most efficient location for your **DESA** direct-vent fireplace. Make sure that rafters and wall studs are not in the way of the venting system. Choose a location where the heat output is not affected by drafts, air conditioning ducts, windows or doors. Figure 2 shows some common locations. Be aware of all restrictions and precautions before deciding the exact location for your fireplace and termination cap.

When deciding the location of your fireplace, follow these rules:

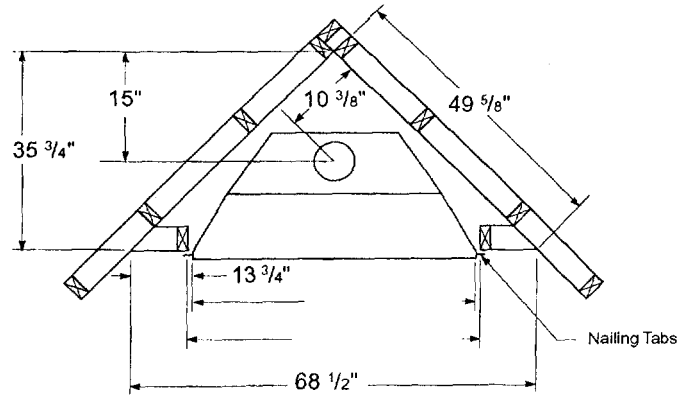
- Do not connect this fireplace venting to a chimney flue serving a separate solid-fuel burning fireplace or appliance.
- Due to high temperatures, do not locate this fireplace in high traffic areas, windy or drafty areas, or near furniture or draperies.
- Proper clearances must be maintained.
- If your fireplace is to be installed directly on carpeting, vinyl tile, or any combustible material other than wood, it must be installed on a metal or wood panel extending the full width and depth of the fireplace. See Figure 3.



**Figure 2 - Common Fireplace Locations**

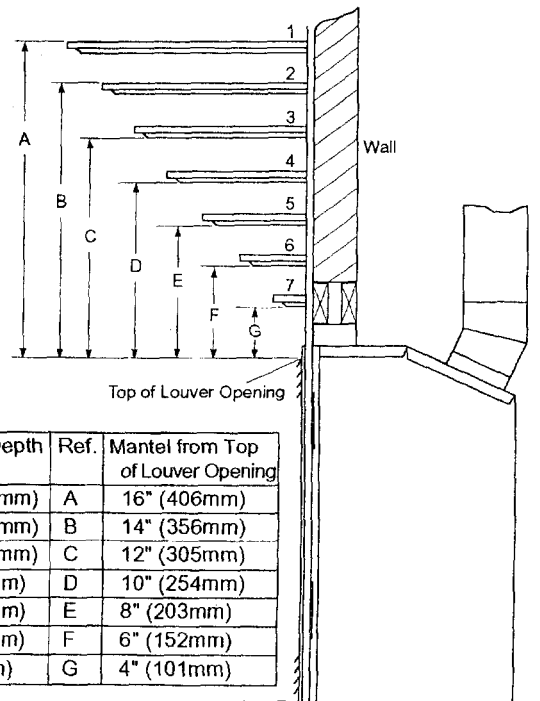


**Figure 3 - Fireplace Bottom Dimensions**



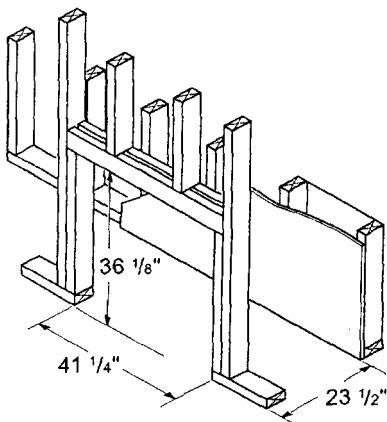
**Figure 5 - Framing Clearances for Corner Installation**

**NOTICE:** This fireplace is intended for use as supplemental heat. Use this fireplace along with your primary heating system. Do not install this fireplace as your primary heat source. If you have a central heating system, you may run system's circulating blower while using fireplace. This will help circulate the heat throughout the house. In the event of a power outage, you can use this fireplace as a heat source.

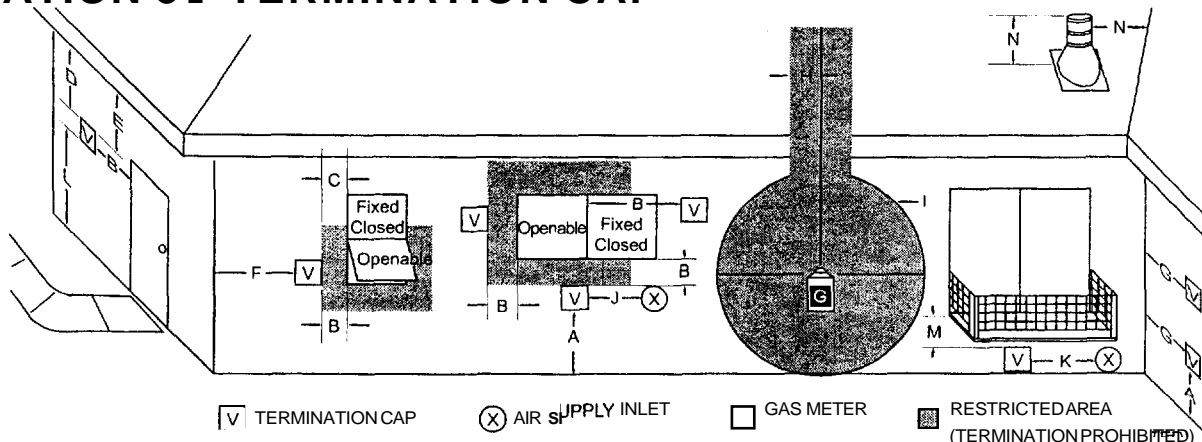


Ref.	Mantel Depth	Ref.	Mantel from Top of Louver Opening
1	14" (356mm)	A	16" (406mm)
2	12" (305mm)	B	14" (356mm)
3	10" (254mm)	C	12" (305mm)
4	8" (203mm)	D	10" (254mm)
5	6" (152mm)	E	8" (203mm)
6	4" (101mm)	F	6" (152mm)
7	2" (51mm)	G	4" (101mm)

**Table Mantels**



# LOCATION OF TERMINATION CAP



- A = clearance above grade, veranda, porch, deck, or balcony (12 inches (30.5cm) minimum)
- B = clearance to window or door that may be opened (12 inches (30.5cm) minimum)
- C = clearance to permanently closed window [minimum 12 inches (30.5cm) recommended to prevent condensation on window]
- D = vertical clearance to ventilated soffit located above the terminal within a horizontal distance of 24 inches (61cm) from the center-line of the terminal [18 inches (45.7cm) minimum]
- E = clearance to unventilated soffit [12 inches (30.5cm) minimum]
- F = clearance to outside corner (see below)
- G = clearance to Inside corner (see below)
- H = not to be installed above a meter/regulator assembly within 36 inches (91.4cm) horizontally from the center-line of the regulator
- I = clearance to service regulator vent outlet [\*72 inches (182.9cm) minimum]
- J = clearance to non-mechanical air supply inlet to building or the combustion air inlet to any other fireplace (12 inches (30.5cm) minimum)
- K = clearance to a mechanical air supply inlet [\*72 inches (182.9cm) minimum]
- L = clearance above paved side-walk or a paved driveway located on public property [\*84 inches (213.3cm) minimum]
- M = clearance under veranda, porch, deck [\*12 inches (30.5cm) minimum]
- N = clearance above a roof shall extend a minimum of 24 inches (61cm) above the highest point when it passes through the roof surface and any other obstruction within a horizontal distance of 18 inches (45.7cm)

vent shall not terminate directly above a side-walk or paved driveway which is located between two single family dwellings and serves both dwellings  
 • only permitted if veranda, porch, deck or balcony is fully open on a minimum of 2 sides beneath the floor as specified in CAN/CSA B149 (.1 or .2) Installation Codes (1991) for Canada and U.S.A.  
 Note: Local codes or regulations may require different clearances

### Termination Clearances for Buildings with Combustible and Noncombustible Exteriors

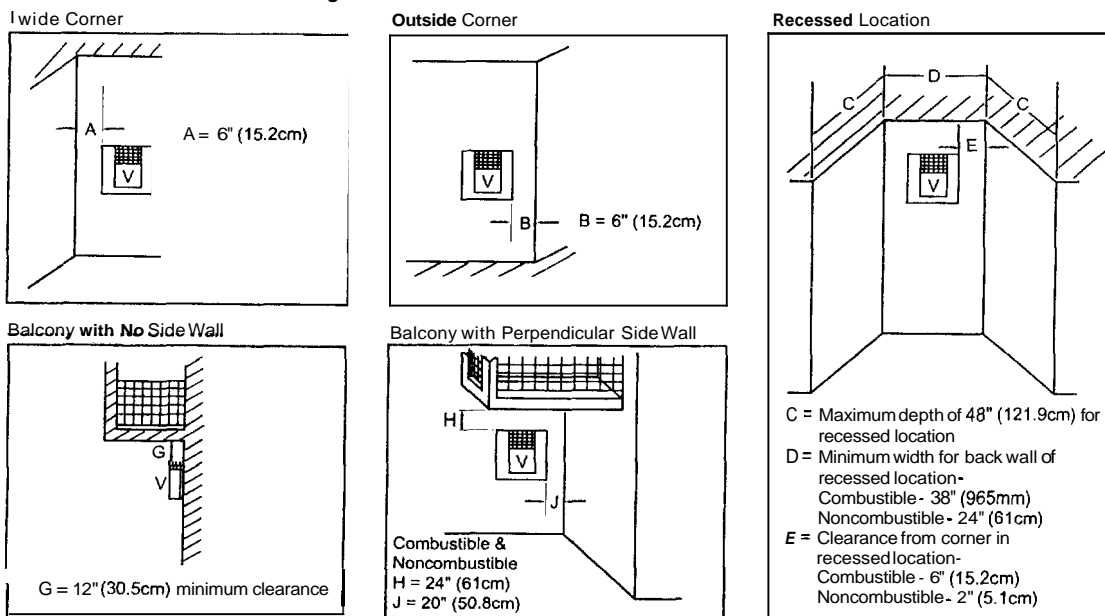


Figure 7- Minimum Clearances for Termination Cap

For more information, visit [www.desatech.com](http://www.desatech.com)



## VENTING INSTALLATION OBJECT

**NOTICE:** Read these instructions completely before attempting installation.

These models are tested and approved for use with DESA (direct-vent) pipe components and terminations.

The venting system must terminate on the outside of the structure and can not be attached to a chimney or flue system serving a separate solid fuel or gas burning appliance. A direct-vent appliance must have its own venting system. **DO NOT** common vent this appliance.

These models are approved to be vented either horizontally through an outside wall or vertically through a roof or chase enclosure using the following guidelines:

- When venting system terminates horizontally on an outside wall, you may install a standoff if the termination cap is to be installed directly on a combustible finish such as vinyl, wood, stucco, etc.
- Never run the vent downward as this may cause excessive temperatures which could cause a fire.
- Vent pipe air space clearances to combustibles are 1" on all sides except on the horizontal section, which requires 2" clearance from the top of the pipe. Where the termination cap penetrates a combustible wall, 1" air space clearance is required.
- Snorkel terminations are required when minimum clearance to grade cannot be met (see Figure 16 on page 11).
- Have fireplace and selected vent components on hand to help determine the exact measurements when elbowing or offsetting. Always use wall firestops when penetrating walls and firestops when penetrating ceilings or attic spaces.
- Install horizontal venting with a 1/4" rise for every 12" of run toward the termination.

**⚠ WARNING:** Read all instructions completely and thoroughly before attempting installation. Failure to do so could result in serious injury, property damage or loss of life.

**NOTICE:** Failure to follow these instructions will void the warranty.

**NOTICE:** Do not seal termination cap to vent pipe. Cap must be removable for vent inspection and maintenance.

## INSTALLATION PRECAUTIONS

- Wear gloves and safety glasses for protection
- Use extreme caution when using ladders or when on roof tops
- Be aware of electrical wiring locations in walls and ceilings

The following actions will void the warranty on your venting system:

- Installation of any damaged venting component
- Unauthorized modification of the venting system (Do not cut or alter vent components)
- Installation of any component part not manufactured or approved by DESA

**Installation other than as instructed by these instructions**

**⚠ WARNING:** This gas fireplace and vent assembly must be vented directly to the outside. The venting system must NEVER be attached to a chimney serving a separate solid fuel burning appliance. Each direct-vent gas appliance must use a separate vent system. Do not use common vent systems.

**A WARNING:** Vent pipe air space clearances to combustibles are 1" on all sides except on the horizontal sections, which require 2" clearances from the top of the pipe. Where the termination cap penetrates a combustible wall, 1" air space clearance is required.

For more information, visit [www.desatech.com](http://www.desatech.com)



## VENTING INSTALLATION INSTRUCTIONS

*Continued*

### INSTALLATION PLANNING

There are two basic types of direct-vent installation:

- Horizontal Termination
- Vertical Termination

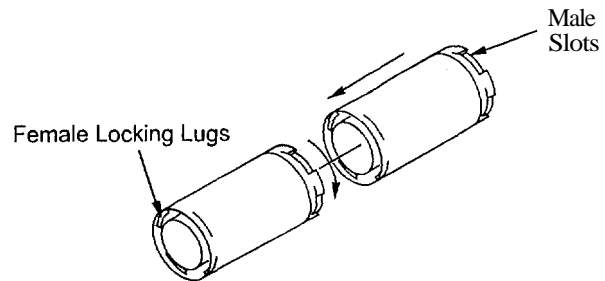
#### Horizontal Termination Installation

**IMPORTANT:** Horizontal square terminations require only inner portion of wall firestop. Horizontal installations using round termination require exterior portion of wall firestop available only in vent kit 01491 for V and VV Series or SDHTRK-58 for CHDV Series (see Figure 14, page 10).

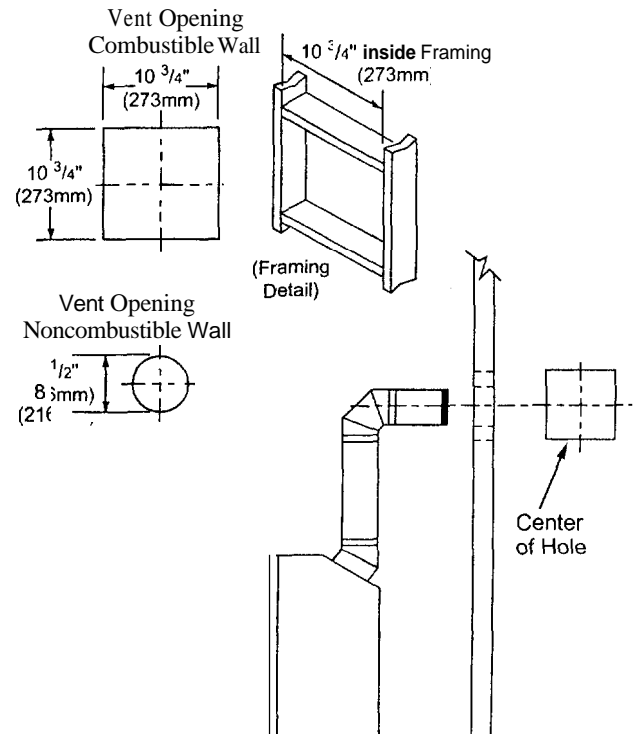
1. Set the fireplace in its desired location and determine the route your horizontal venting will take. Do not secure the fireplace until all venting has been installed. Some installations require sliding the fireplace in and out of position to make final venting connections. Figures 14 through 18 on pages 10 through 12 show different configurations for venting with horizontal termination that will help you decide which application best suits your installation. Check to see if wall studs or roof rafters are in the path of your desired venting route. If they are, you may want to adjust the location of the fireplace.
2. Direct vent pipe sections and components are designed with special twist-lock connections.

**Twist-Lock Procedure:** The female ends of the pipes have locking lugs (indentations). These lugs will slide straight into matching slots on the male ends of adjacent pipes. Push pipe sections together and twist one section clockwise approximately one-quarter turn until the sections are fully locked (see Figure 8). **Note:** Horizontal runs of vent must be supported every three feet. Use wall straps for this purpose.

3. Use a 45° elbow to connect venting system to fireplace flue collar. The elbow is designed to be twist-locked onto the flue collar as described in step 2. **IMPORTANT** Do not attempt to alter the configuration of the elbow by cutting, twisting, bending, etc.
4. Assemble the desired combination of pipe and elbows to the fireplace flue collar. If there are long portions of venting run, pre-assembled pipe sections may be installed as subassemblies for convenience.
5. Carefully determine the location where the vent pipe assembly will penetrate the outside wall. The center of the hole should line up with the center-line of the horizontal vent pipe. Mark the wall for a 10<sup>3</sup>/<sub>4</sub>" x 10<sup>3</sup>/<sub>4</sub>" square hole. Cut and frame the square hole in the exterior wall where the vent will be terminated. If the wall being penetrated is constructed of noncombustible material, such as masonry block or concrete, a 8<sup>1</sup>/<sub>2</sub>" hole with zero clearance is acceptable (see Figure 9).



**Figure 8 - Vent Pipe Connections**

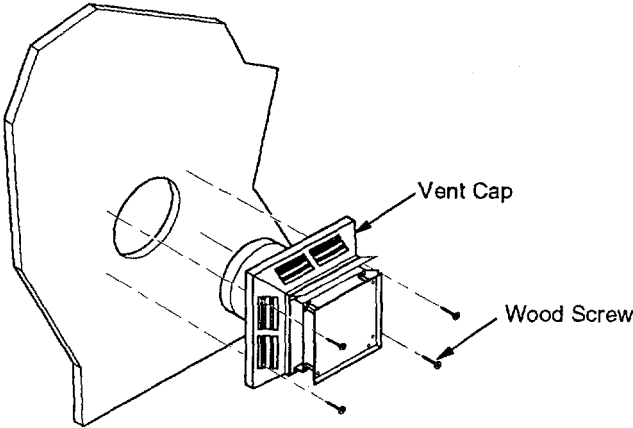
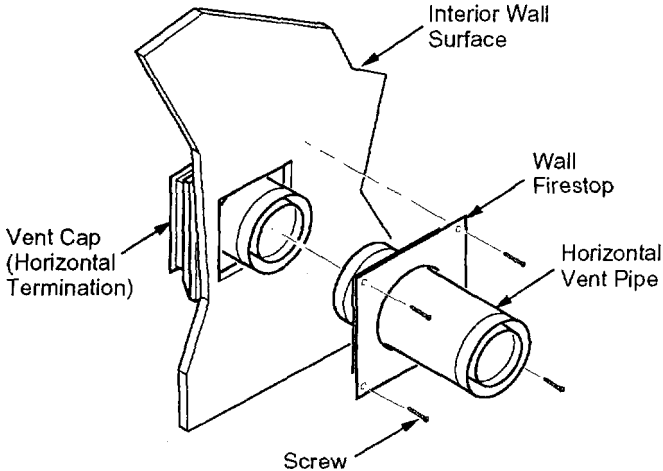
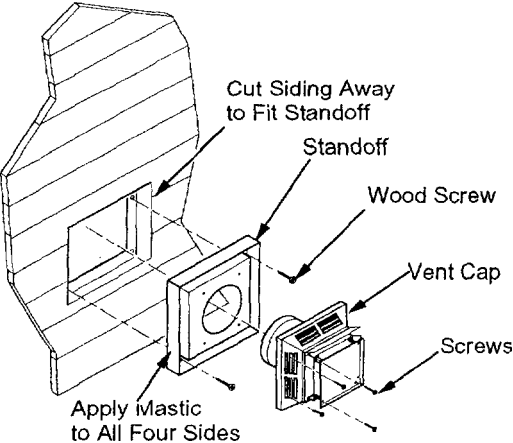


**Figure 9 - Vent Opening Requirements**

# VENTING INSTALLATION INSTRUCTIONS

*Continued*

**⚠ WARNING:** Do not recess vent termination into any wall. This will cause a fire hazard.



For more information, visit [www.desatech.com](http://www.desatech.com)



## VENTING INSTALLATION INSTRUCTIONS

### Continued

9. Combustible Exterior Wall Only: Slide wall firestop against interior wall surface and attach with screws provided. See Figure 13 for horizontal termination details.
10. Place fireplace into position and shim with noncombustible material if needed. Nail or screw side flanges to framing to secure unit in place. **IMPORTANT** Make **sure** fireplace is level before securing. **If** fireplace is not level it will not work properly.

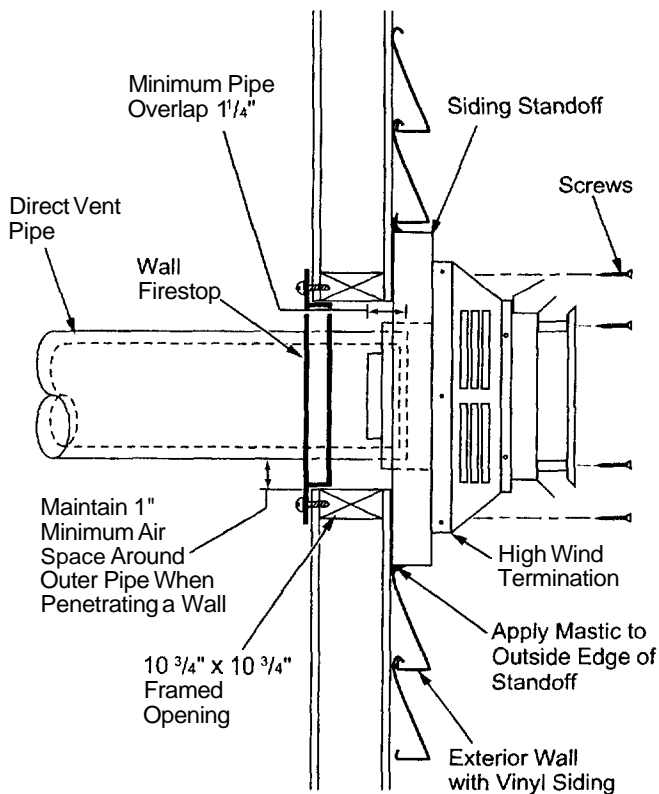


Figure 13- Typical Horizontal Termination Cap Mounting with Additional Siding Standoff Installed

### Horizontal Termination Configurations

Figures 14 through 18 show different configurations and alternatives for venting with horizontal termination. Each figure includes a chart with critical minimum and maximum dimensions which **MUST** be met. **IMPORTANT:** Remember that a horizontal run of venting must have a 1/4" rise for every 12" of run toward the termination.

**NOTICE:** Do not seal termination cap to vent pipe. Cap must be removable for vent inspection and maintenance.

**⚠ WARNING:** Never run vent downward as this may cause excessive temperatures which could cause a fire. Operation of improperly installed and maintained venting system could result in serious injury, property damage or loss of life.

### GROUND FLOOR INSTALLATION

Recommended Applications:

- Installation using cabinet surrounds
- Through the wall using round or square termination (up to 12" horizontal pipe)
- NOT FOR CORNER INSTALLATION

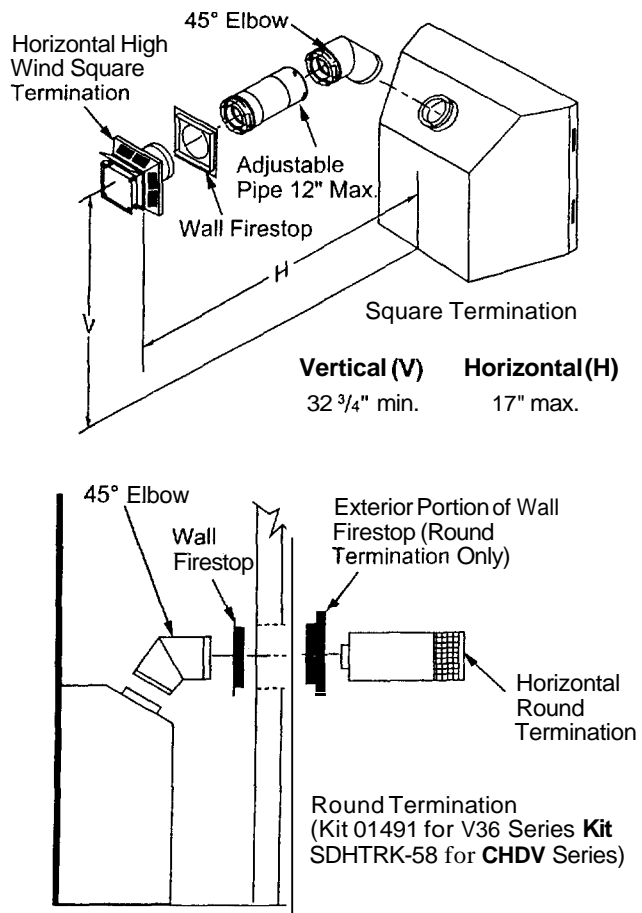


Figure 14- Horizontal Termination Configuration for Square or Round Terminations

For more information, visit [www.desatech.com](http://www.desatech.com)

# VENTING INSTALLATION INSTRUCTIONS

Continued

## CORNER INSTALLATION

Recommended Applications:

- Corner ground floor installation
- Ground floor installation where pipe vents horizontally through wall (over 12" horizontal pipe)
- Basement installation where one foot clearance from ground to termination is possible

Vertical (V)	Required	
	Vertical Pipe	Horizontal (H)
*43 1/2" min.	None	30" max.
54 1/2" min.	1 ft.	48" max.
66 1/2" min.	2 ft.	60" max.
78 1/2" min.	3 ft.	84" max.
90 1/2" min.	4 ft.	20' max.

\* Ground Floor Corner Venting

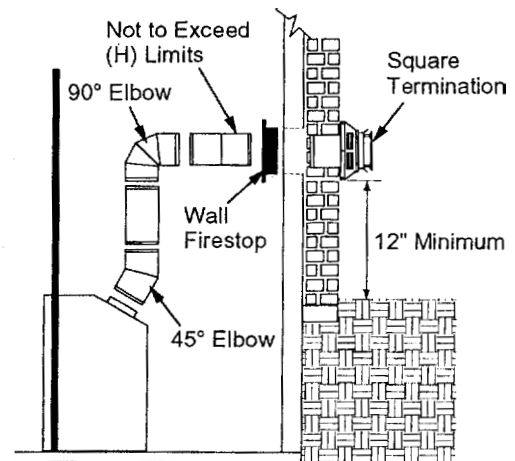
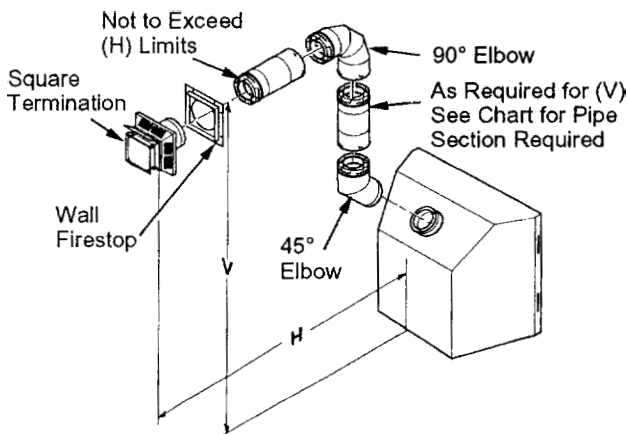


Figure 15- Horizontal Termination Configuration for Corner Installation Using One 90° Elbow

## SNORKEL TERMINATION INSTALLATION

Recommended Applications:

- Installations requiring a vertical rise on building exterior
- Any installation using snorkel termination to achieve one foot above ground

Snorkel terminations are available for installations requiring a vertical rise on the exterior of the building. If installing snorkel termination below grade, you must provide proper drainage to prevent water from entering snorkel termination (see Figure 16). Do not back fill around snorkel termination.

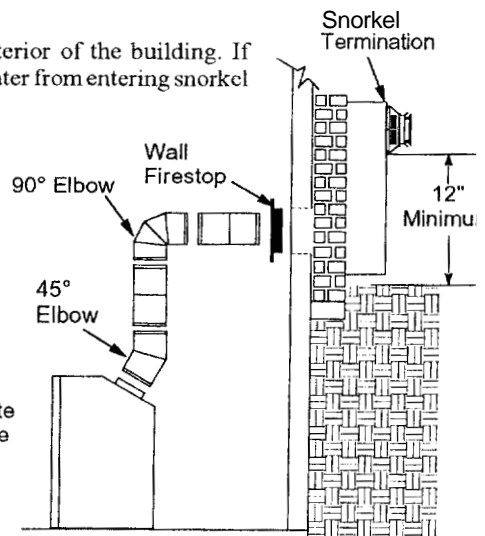
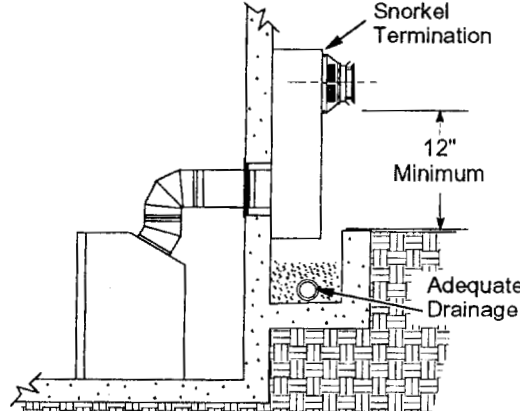
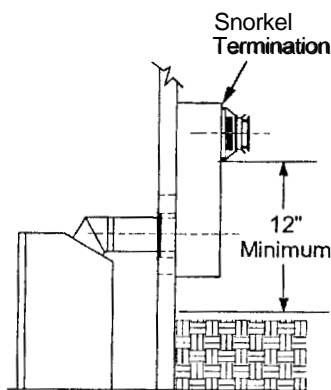


Figure 16 - Snorkel Termination Configurations for Below Ground Installation

For more information, visit [www.desatech.com](http://www.desatech.com)



# VENTING INSTALLATION INSTRUCTIONS

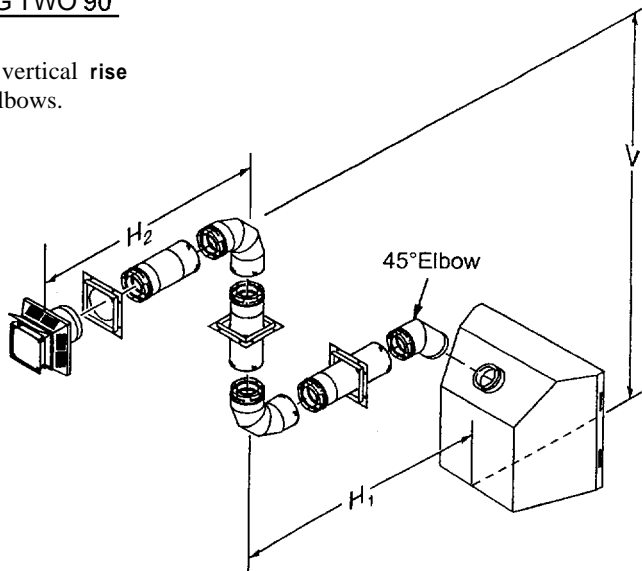
*Continued*

## HORIZONTAL SYSTEM INSTALLATION USING TWO 90° ELBOWS

The following configurations show the minimum vertical rise requirements for a horizontal system using two 90° elbows.

### Venting with Two 90° Elbows

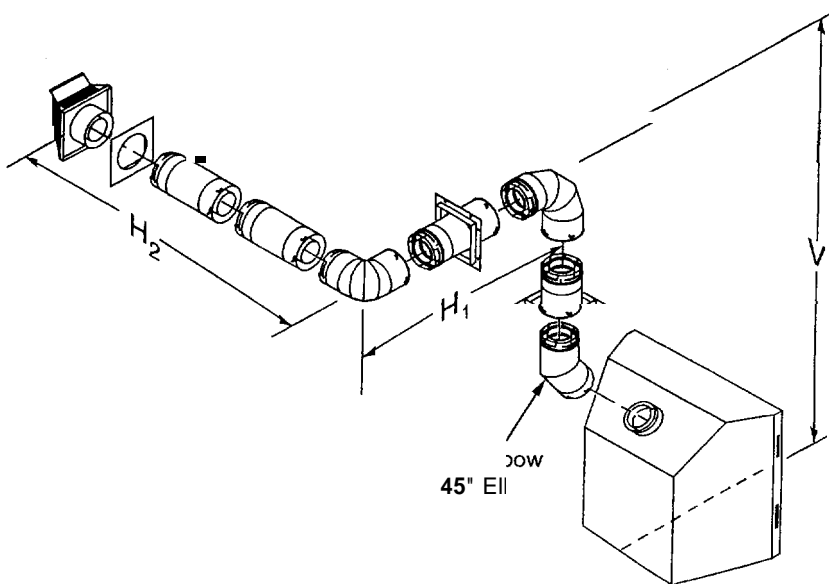
Vertical (V)	Horizontal (H <sub>1</sub> )	Horizontal (H <sub>1</sub> ) + Horizontal (H <sub>2</sub> )
5' min.	2' max.	6' max.
6' min.	4' max.	12' max.
7' min.	6' max.	18' max.
8' min.	8' max.	20' max.
20' max.	8' max.	20' max.



**Figure 17- Horizontal Termination Configuration for Venting Using Two 90° Elbows**

### Venting with Two 90° Elbows

Vertical (V)	Horizontal (H <sub>1</sub> ) + Horizontal (H <sub>2</sub> )
5' min.	6' max.
6' min.	12' max.
7' min.	18' max.
8' min.	20' max.
20' max.	20' max.



**Figure 18 - Horizontal Termination Configuration for Venting Using Two 90° Elbows with Termination at 90° with Fireplace**

**For more information, visit [www.desatech.com](http://www.desatech.com)**

# VENTING INSTALLATION INSTRUCTIONS

Continued

## INSTALLATION FOR VERTICAL TERMINATION

*Note:* Vertical restrictor must be installed in all vertical installations.

1. Determine the route your vertical venting will take. If ceiling joists, roof rafters, or other framing will obstruct the venting system, consider an offset (see Figure 19) to avoid cutting load bearing members. *Note:* Pay special attention to these installation instructions for required clearances (air space) to combustibles when passing through ceilings, walls, roofs, enclosures, attic rafters, etc. Do not pack air spaces with insulation. **Also** note maximum vertical rise of the venting system and any maximum horizontal offset limitations.
2. Set the fireplace in desired location. Drop a plumb line down from the ceiling to the position of the fireplace exit flue. Mark the center point where the vent will penetrate the ceiling. Drill a small locating hole at this point.

Drop a plumb line from the inside of the roof to the locating hole in the ceiling. Mark the center point where the vent will penetrate the roof. Drill a small locating hole at *this* point.

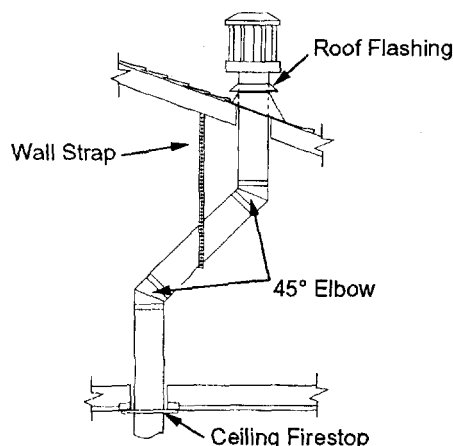


Figure 19- Offset with Wall Strap and 45° Elbows

### Flat Ceiling Installation

1. Cut a 10<sup>3</sup>/<sub>4</sub>" square hole in the ceiling using the locating hole as a center point. The opening should be framed to 10<sup>3</sup>/<sub>4</sub>" x 10<sup>3</sup>/<sub>4</sub>" (273mm x 273mm) inside dimensions, as shown in Figure 9 on page 8 using framing lumber the same size as the ceiling joists. If the area above the ceiling is an insulated ceiling or a room, nail firestop from the top side. This prevents loose insulation from falling into the required clearance space. Otherwise, install firestop below the framed hole. The firestop should be installed with no less than three **nails** per side (see Figure 20).

2. Assemble the desired lengths of pipe and elbows necessary to reach from the fireplace flue up through the firestop. Be sure all pipe and elbow connections are fully twist-locked (see Figure 8, page 8).
3. Cut a hole in the roof using the locating hole as a center point. (Cover any exposed open vent pipes before cutting hole in roof.) The 10<sup>3</sup>/<sub>4</sub>" x 10<sup>3</sup>/<sub>4</sub>" hole must be measured on the horizontal; actual length may be larger depending on the pitch of the roof. There must be a 1" clearance from the vent pipe to combustible materials. Frame the opening as shown in Figure 9, page 8.
4. Connect a section of pipe and extend up through the hole.
 

*Note:* If an offset is needed to avoid obstructions, you must support the vent pipe every 3 feet. Use wall straps for this purpose (see Figure 19). Whenever possible, use 45° elbows instead of 90° elbows. The 45° elbow offers less restriction to the flow of the flue gases and intake air.
5. Place the flashing over the pipe section(s) extending through the roof. Secure the base of the flashing to the roof and framing with roofing nails. Be sure roofing material overlaps the top edge of the flashing as shown in Figure 19. There must be a 1" clearance from the vent pipe to combustible materials.
6. Continue to add pipe sections until the height of the vent cap meets the minimum building code requirements described in Figure 7 on page 6. *Note:* You must increase vent height for steep roof pitches. Nearby trees, adjoining rooflines, steep pitched roofs, and other similar factors may cause poor draft or down-drafting in high winds. Increasing the vent height may solve this problem.
7. Twist-lock the vent cap onto the last section of vent pipe.

*Note:* If the vent pipe passes through any occupied areas above the first floor, including storage spaces and closets, you must enclose pipe. You may frame and sheetrock the enclosure with standard construction material. Make sure and meet the minimum allowable clearances to combustibles. Do not fill any of the required air spaces with insulation.

If area above is a room, install firestop above framed hole. If area above is not a room, install firestop below framed hole.

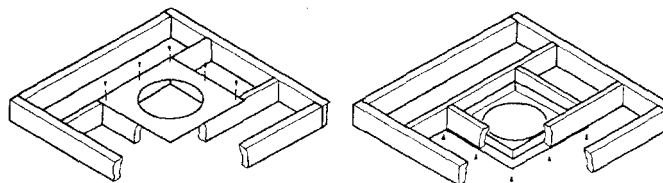


Figure 20 - Installing Firestop



# VENTING INSTALLATION INSTRUCTIONS

Continued

## Vertical Termination Configurations

Figures 21 through 24 show four different configurations for vertical termination.

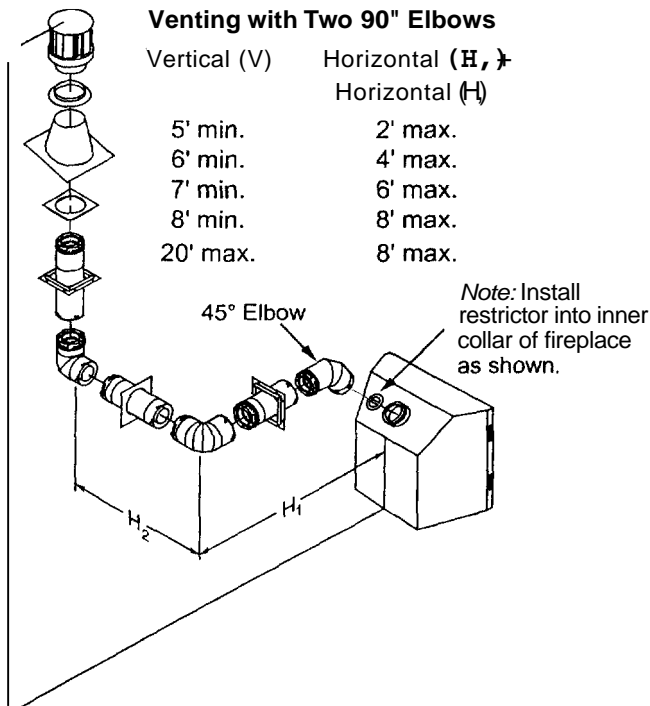


Figure 21- Vertical Venting Configuration Using Two 90° Elbows with Two Horizontal Runs (Vertical Round High Wind Termination Shown)

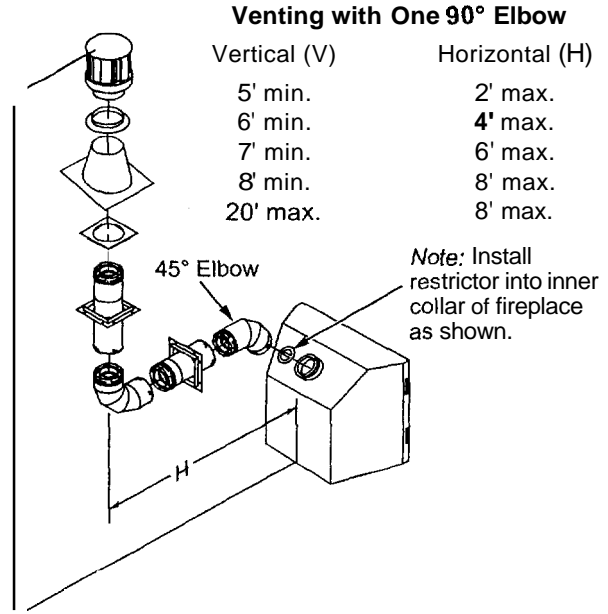


Figure 22- Vertical Venting configuration Using One 90° Elbow (Vertical Round High Wind Termination Shown)

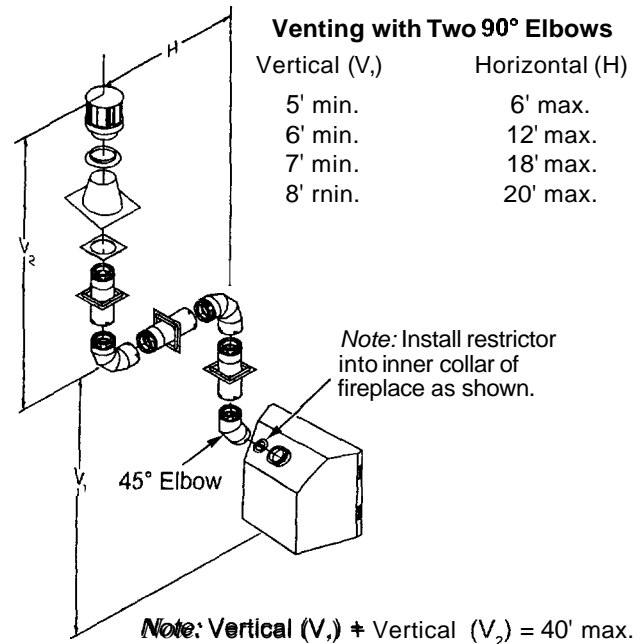


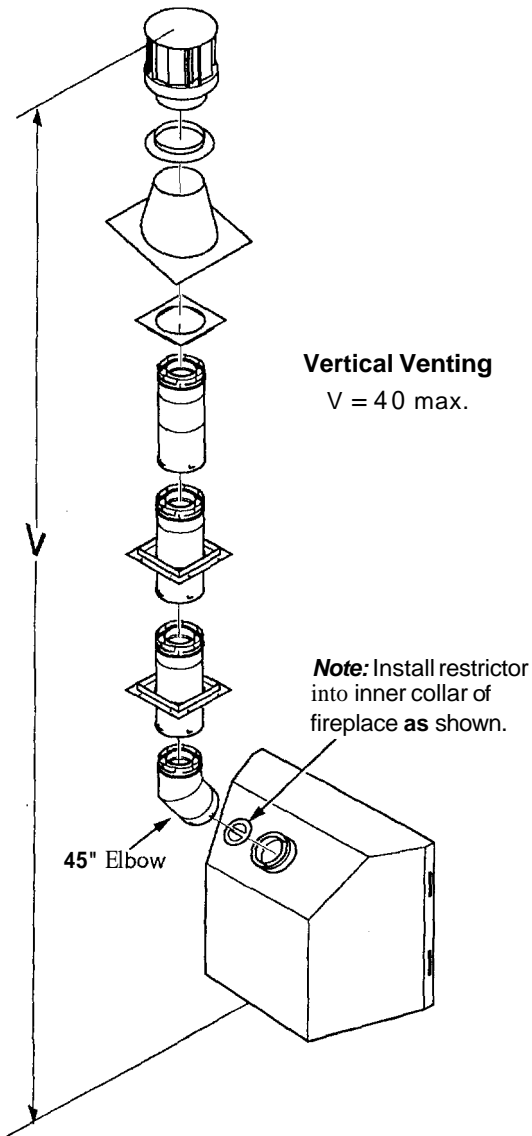
Figure 23- Vertical Venting Configuration Using Two 90° Elbows (Vertical Round High Wind Termination Shown)

For more information, visit [www.desatech.com](http://www.desatech.com)



# VENTING INSTALLATION INSTRUCTIONS

*Continued*



**Figure 24 - Vertical Venting Configuration With No Horizontal Run (Vertical Round High Wind Termination Shown)**

## HIGH ALTITUDE INSTALLATION

Your **DESA** direct-vent fireplace has been tested and approved for elevations from 0-2000 feet (**USA**) and elevations from 0-4500 feet (Canada).

When installing this fireplace at an elevation above 2000 feet (in the **USA**), you may need to decrease the input rating by changing the existing burner orifice to a smaller size. Reduce input 4% for each 1000 feet above sea level. Check with your local gas company for proper orifice size identification.

When installing this fireplace at an elevation above 4500 feet (in Canada), check with local authorities.

Consult your local gas company to help determine the proper orifice for your location.

For assistance with any **high** altitude installation contact **DESA's** Customer Service Department at 1-866-672-6040.

## PARTS LISTS FOR VENTING KITS AND COMPONENTS FOR V36 AND W36 SERIES

### DESA (5/8") Pipe & Vent Kits

Number	Description
P58-6	6" Section Double Wall Pipe, Galvanized
P58-12	12" Section Double Wall Pipe, Galvanized
P58-24	24" Section Double Wall Pipe, Galvanized
P58-36	36" Section Double Wall Pipe, Galvanized
P58-48	48" Section Double Wall Pipe, Galvanized
PA58-712	Adjustable 7"-12" Section Double Wall Pipe, Galvanized
FPA58-6	6" Duravent Collar to FMI Pipe Adaptor (6" collar/Pipe Section)
DPA58-6	6" FMI Collar to Pipe Duravent Adaptor (6" collar/Pipe Section)
E58-45	45 deg. Elbow, Galvanized
E58-90	90 deg. Elbow, Galvanized
FSE58-45	45 deg. Starter Elbow, Galvanized (Duravent Collar to FMI Pipe)
DSE58-45	45 deg. Starter Elbow, Galvanized (FMI Collar to Duravent Pipe)
VKG-58	Ground Floor Vent Kit
VKB-58	Basement Vent Kit
VKS-58	Snorkel Vent Kit
VKR-58	Roof Vent Kit
VKC-58	Corner Vent Kit
HTK	Horizontal Round Termination Kit
HT-58	Horizontal Round Termination, Galvanized
HTS-58	Horizontal Square Termination, Galvanized
VT-58	Vertical Round Termination, Galvanized
ST-58-14	14" Snorkel Termination, Galvanized
ST-58-36	36" Snorkel Termination, Galvanized
SC-58	Storm Collar, Galvanized
WF-58	Wall Firestop, Galvanized
RF-58-6	Roof Flashing - 0 to 6/12 Pitch, Galvanized
RF-58-12	Roof Flashing - 6/12 to 12/12 Pitch, Galvanized
VR-58	Vertical Restrictor, Galvanized

**For more information, visit [www.desatech.com](http://www.desatech.com)**



**VENTING INSTALLATION INSTRUCTIONS***Parts Lists for Venting Kits and Components for V36 and VV36 Series (Cont.)**Parts Lists for Venting Kits and Components for VV361 Model Series**Parts Lists for Venting Kits and Components for CHDV Model Series***VENTING INSTALLATION INSTRUCTIONS****Continued****PARTS LISTS FOR VENTING KITS AND COMPONENTS FOR V36 AND W36 SERIES (CONT.)**

Number	Description
S-58	Vinyl Siding Standoff, Galvanized
WS-58	Wall Strap
CS-58	Cathedral Ceiling Support
FP-58	Firestop Plate
SF-58	Stucco Flashing - For use with HTS-5

**PARTS LISTS FOR VENTING KITS AND COMPONENTS FOR W361 SERIES****DESA (5/8") Pipe & Vent Kits**

Number	Description
01492	Horizontal Square Termination Kit Includes: 45° Elbow (Through 5" Wall), Wall Firestop, Horizontal Square Termination
01493	Basic Vertical Termination Kit Includes: Vertical Termination, Adjustable Flashing, Storm Collar
01491	Horizontal Round Termination Kit Includes: Round Termination, Wall Firestop, and 45° Elbow (Through 5" Wall)
01497	12" Section Coaxial Pipe - Galvanized (4)
01498	18" Section Coaxial Pipe - Galvanized (4)
01499	24" Section Coaxial Pipe - Galvanized (4)
01500	36" Section Coaxial Pipe - Galvanized (4)
01501	48" Section Coaxial Pipe - Galvanized (4)
01513	6 Section Coaxial Pipe - Galvanized (4)
01606	Adjustable 17"-24" Section Coaxial Pipe - Galvanized (4)
F8030	Adjustable 7"-12 Section Coaxial Pipe - Galvanized (6)
D1032	Adjustable 7-12" Section Coaxial Pipe - Galvanized (1)

**DESA Elbows**

Number	Description
01502	45° Elbow - Galvanized (4)
01503	90° Elbow - Galvanized (4)

**DESA Terminations**

Number	Description
01494	Vertical Round Termination - Galvanized (1)
01495	Horizontal Round Termination - Galvanized (1)
01496	Horizontal Square Termination - Galvanized (1)
01798	Vertical Round High Wind Termination (1)
01800	Horizontal Square High Wind Termination (1)
01801	14" Snorkel Termination - Galvanized (1)
01802	36" Snorkel Termination - Galvanized (1)

**DESA Venting Accessories**

Number	Description
01504	Firestop Plate (4)
01505	Adjustable Roof Flashing [0 - 8/12] - Galvanized (6)

01506	Steep Pitch Flashing 9/12 to 12/12 - Galvanized (6)
01507	Storm Collar - Galvanized (4)
01508	Wall Strap (4)
01514	Combustible Siding Standoff - Galvanized (1)
01607	Wall Firestop - Galvanized (4)
VR-58	Vertical Restrictor - Galvanized

**PARTS LISTS FOR VENTING KITS AND COMPONENTS FOR CHDV MODEL SERIES****DESA (5/8") Pipe & Vent Kits**

Number	Description
SDHTSK-58	Horizontal Square Termination Kit Includes: 45° Elbow (Through 5" Wall), Wall Firestop, Horizontal Square Termination
SDHTBK-58	Basic Vertical Termination Kit Includes: Vertical Termination, Adjustable Flashing, Storm Collar
SDHTRK-58	Horizontal Round Termination Kit Includes: Round Termination, Wall Firestop, and 45° Elbow (Through 5" Wall)
SDP58-12	12" Section Coaxial Pipe - Galvanized (1)
SDP58-18	18" Section Coaxial Pipe - Galvanized (1)
SDP58-24	24" Section Coaxial Pipe - Galvanized (1)
SDP58-36	36 Section Coaxial Pipe - Galvanized (1)
SDP58-48	48" Section Coaxial Pipe - Galvanized (1)
SDP58-6	6" Section Coaxial Pipe - Galvanized (1)
SDAP58-1724	Adjustable 17"-24" Section Coaxial Pipe - Galvanized (1)
SDAP58-712	Adjustable 7"-12" Section Coaxial Pipe - Galvanized (1)

**DESA Elbows**

Number	Description
SDE58-45	45° Elbow - Galvanized (1)
SDE58-90	90° Elbow - Galvanized (1)

**DESA Terminations**

Number	Description
SDVT-58	Vertical Round Termination - Galvanized (1)
SDHT-58	Horizontal Round Termination - Galvanized (1)
SDHTS-58	Horizontal Square Termination - Galvanized (1)
SDVSWT-58	Vertical Round High Wind Termination (1)
SDHSWT-58	Horizontal Square High Wind Termination (1)
SDST14-58	14" Snorkel Termination - Galvanized (1)
SDST36-58	36" Snorkel Termination - Galvanized (1)

**DESA Venting Accessories**

Number	Description
SDFSP-58	Firestop Plate (1)
SDAF-58	Adjustable Roof Flashing [0 - 8/12] - Galvanized (1)
SDSC-58	Storm Collar - Galvanized (1)
SDWS-58	Wall Strap (1)
SDS-58	Combustible Siding Standoff - Galvanized (1)
SDSPF-58	Steep Pitch Flashing [9/12 - 12/12] - Galvanized (1)
SDWFS-58	Wall Firestop - Galvanized (1)
VR-58	Vertical Restrictor - Galvanized (1)

**For more information, visit [www.desatech.com](http://www.desatech.com)**

## FIREPLACE INSTALLATION CHECK GAS TYPE

Use proper gas type for the fireplace unit you are installing. If you have conflicting gas types, do not install fireplace. See retailer where you purchased the fireplace for proper fireplace according to your gas type or to purchase gas conversion kit (see *Accessories*, page 39).

### INSTALLING OPTIONAL BLOWER ACCESSORIES

**NOTICE:** If installing blower in an existing fireplace with gas connections, shut off gas supply and disconnect heater from gas supply. Contact a qualified service person to do this.

**WARNING:** If there is a duplex electrical outlet

is turned off before proceeding with blower installation. Failure to do this may result in serious injury.

Follow all instructions provided in the blower accessory kit.

1. Attach the power cord to the blower motor by firmly pushing the two female terminals at the end of the power cord onto the two spade terminals on the blower motor (see Figure 25).
2. Attach green ground wire from power cord to blower housing using screw provided (see Figure 25). Tighten screws securely.
3. Place the blower against the lower rear wall of the firebox outer wrapper with the exhaust port directed upward. The blower will fit inside the back opening and be held in position against the back wall by the magnets (see Figure 25).
4. Be certain that all wire terminals are securely attached to terminals on blower motor and that the screw retaining the green ground wire is tight.
5. Mount speed control box to switch bracket by placing the plastic control shaft forward through the round opening in the switch bracket (see Figure 26).

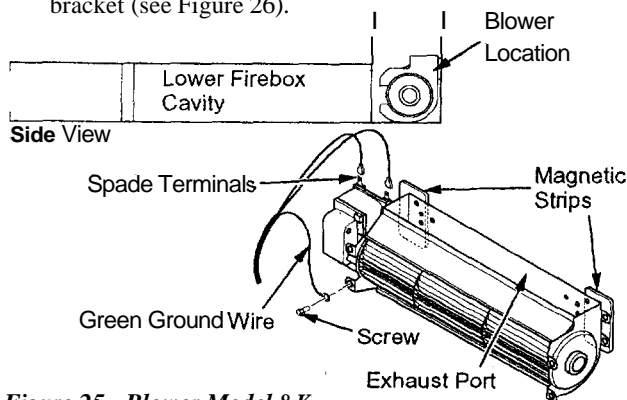


Figure 25 - Blower Model 8 K

6. While supporting speed control, secure control shaft with lock nut by pushing and turning lock nut with pliers clockwise until it is tight against front panel. Place control knob provided on shaft.
7. Turn on power to duplex outlet if previously turned off per the warning in column 1.
8. Plug in blower power cord.
  - a. If your firebox is installed as a freestanding unit with an accessory mantel, determine whether the power cord will exit the left side or the right side of the firebox. Route power cord through exit hole and plug the power cord into a wall receptacle near the firebox.
  - b. If your firebox installation is recessed and/or pre-wired, plug the power cord into the duplex outlet provided. Refer to your firebox owner's manual for instructions on wiring the duplex outlet.

#### operation.

9. Check to make sure that the power cord is completely clear of the

by turning knob fully counterclockwise before continuing.

10. Peel off the backing paper and stick the supplied wiring diagram decal on the firebox bottom approximately 12" in front of the blower (see Figure 27).

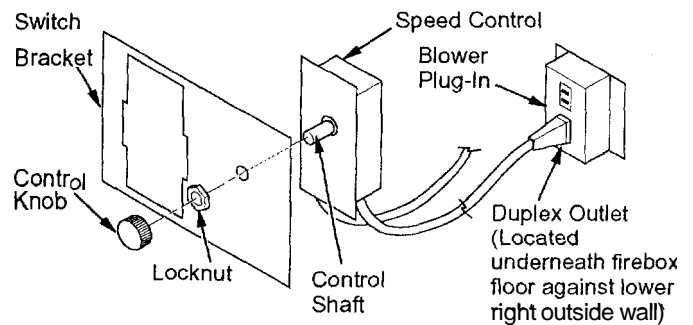


Figure 26 - Attaching Speed Control to Firebox

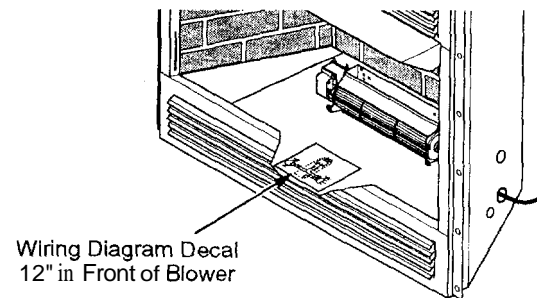


Figure 27 - Location of Wiring Diagram Decal (Model May Vary From Illustration)

For more information, visit [www.desatech.com](http://www.desatech.com)

**DESA**

## FIREPLACE INSTALLATION

### Continued

#### Model BKT Installation

**Note:** When installing the BKT thermostatically-controlled blower, you must first secure the thermal switch bracket to the blower if it has not already been factory installed.

1. Place the green ground wire with ring terminal between the bottom hole on the thermal switch bracket and the top ear hole on the blower assembly. Insert the phillips screw into all three pieces and tighten securely (see Figure 28).
2. Connect wire harness and power cord terminals. Connect the blue jumper wire to the blower motor terminal and the right side terminal of the thermal switch. Connect the black wire to the left side of the thermal switch and the white wire to the other remaining blower motor terminal.

**Note:** The power cord outer insulation sleeve may have to be stripped slightly to allow enough wire length to reach and make all connections. **DO NOT** trim excessive length away. Just enable enough to make all connections securely.

3. Place the blower against the lower rear wall of the firebox outer wrapper with the exhaust port directed upward and the thermodisc positioned up near the fireplace bottom. The thermodisc must be oriented near the fireplace bottom as shown in Figure 28 in order to sense temperature and properly operate. The blower will be held in position against the back wall by the magnets incorporated onto the blower housing (see Figure 28).
4. Be certain that all wire terminals are securely attached to terminals on blower motor and thermal switch, and that the screw for the thermodisc bracket and green ground wire is tight.

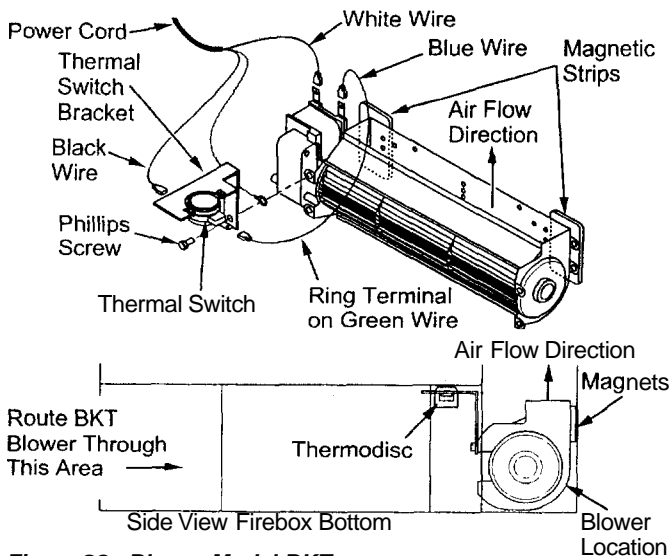


Figure 28 - Blower Model BKT

5. Mount the speed control box against the mounting plate provided in the lower fireplace cavity by placing the plastic control shaft forward through the round hole (see Figure 26, page 17).
6. While supporting speed control, secure control shaft with lock nut by pushing and turning lock nut with pliers clockwise until it is tight against mounting plate. Place control knob provided on shaft (see Figure 26, page 17).
7. Check to make sure that the power cord is completely clear of the blower wheel and that there are no other foreign objects in blower wheel. Also double check all wire leads and make sure wire routing is not pinched or in a precarious position. Correct accordingly.
8. Turn on power to duplex outlet if previously turned off per the warning in column 1, page 17.
9. Plug in blower power cord to duplex outlet.
10. The blower will only run when the speed control knob is in the ON position and the thermal switch senses temperature after the fireplace begins to heat up. The blower speed can be adjusted by rotating the control knob. To turn off, turn knob fully counter-clockwise until it clicks off. If the blower is ON and has been running with the fireplace operating, the blower will continue to run for a short time after the fireplace has been turned off. As the thermal switch cools down, the blower shuts down automatically.
11. Peel off the backing paper and stick the supplied wiring diagram decal on the firebox bottom approximately 12" in front of the blower (see Figure 27).

#### Blower Wiring Diagram

**CAUTION:** Label all wires prior to disconnection when servicing controls. Wiring errors can cause improper and dangerous operation. Verify proper operation after servicing.

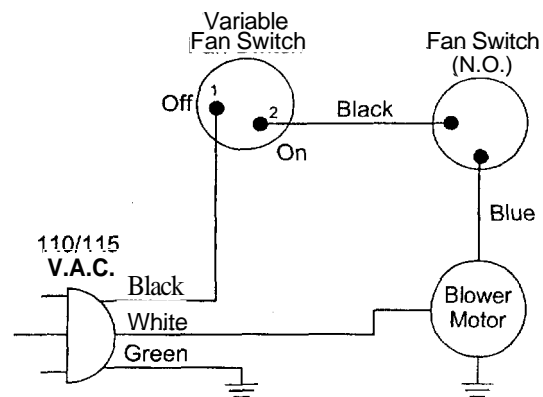


Figure 29 - Blower Wiring Diagram for Thermostat-Controlled Models

# FIREPLACE INSTALLATION

*Continued*

## INSTALLING GAS PIPING TO FIREPLACE LOCATION

**⚠ WARNING:** A qualified service person must connect fireplace to gas supply. Follow all local codes.

**⚠ CAUTION:** For propane/LP units, never connect fireplace directly to the propane/LP supply. This heater requires an external regulator (not supplied). Install the external regulator between the fireplace and propane/LP supply.

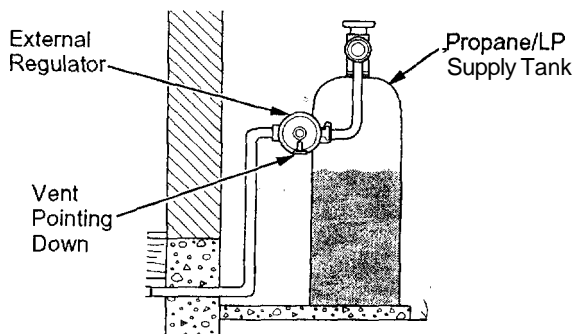
### Installation Items Needed

Before installing fireplace, make sure you have the items listed below.

- external regulator (supplied by installer)
- piping (check local codes)
- sealant (resistant to propane/LP gas)
- equipment shutoff valve \*
- test gauge connection \*
- sediment trap
- tee joint
- pipewrench
- approved flexible gas line with gas connector (if allowed by local codes)

\* A CSA design-certified equipment shutoff valve with 1/8" NPT tap is an acceptable alternative to test gauge connection. Purchase the CSA design-certified equipment shutoff valve from your retailer.

For propane/LP connection only, the installer must supply an external regulator. The external regulator **will** reduce incoming gas pressure. You must reduce incoming gas pressure to between 11 and 14 inches of water. If you do not reduce incoming gas pressure, fireplace regulator damage could occur. Install external regulator with the vent pointing down as shown in Figure 30. Pointing the vent down protects it from freezing rain or sleet.



**Figure 30 - External Regulator with Vent Pointing Down (Propane/LP Only)**

**⚠ CAUTION:** Use only new, black iron or steel pipe. Internally-tinned copper tubing may be used in certain areas. Check your local codes. Use pipe of 1/2" diameter or greater to allow proper gas volume to fireplace. If pipe is too small, undue loss of volume will occur.

Installation must include an equipment shutoff valve, union, and plugged 1/8" NPT tap. Locate NPT tap within reach for test gauge hook up. NPT tap must be upstream from fireplace (see Figure 31).

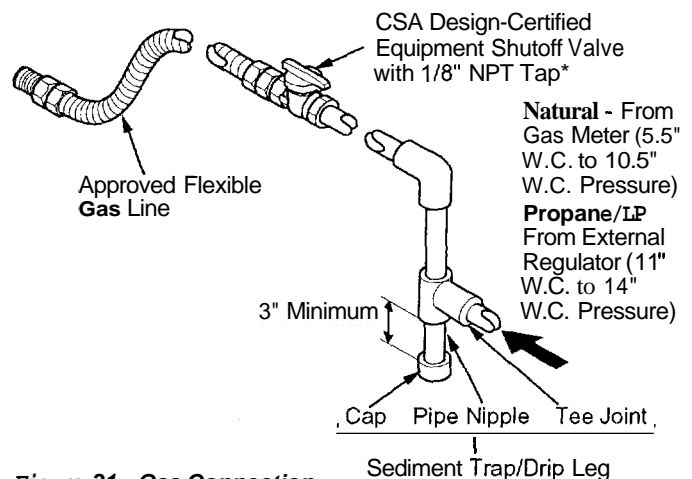
**IMPORTANT:** Install main gas valve (equipment shutoff valve) in an accessible location. The main gas valve is for turning on or shutting off the gas to the appliance.

Check your building codes for any special requirements for locating equipment shutoff valve to fireplaces.

Apply pipe joint sealant lightly to male NPT threads. This will prevent excess sealant from going into pipe. Excess sealant in pipe could result in clogged fireplace valves.

**⚠ WARNING:** Use pipe joint sealant that is resistant to liquid petroleum (LP) gas.

We recommend that you install a sediment trap/drip leg in supply line as shown in Figure 31. Locate sediment trap/drip leg where it is within reach for cleaning. Install in piping system between fuel supply and fireplace. Locate sediment trap/drip leg where trapped matter is not likely to freeze. A sediment trap traps moisture and contaminants. This keeps them from going into fireplace gas controls. If sediment trap/drip leg is not installed or is installed wrong, fireplace may not run properly.



**Figure 31 - Gas Connection**

\* The CSA design-certified equipment shutoff valve may be supplied with the appliance or you can purchase it from your retailer.

**For more information, visit [www.desatech.com](http://www.desatech.com)**



## FIREPLACE INSTALLATION

*Continued*

### CONNECTING FIREPLACE TO GAS SUPPLY

#### Installation Items Needed

- 5/16" hex socket wrench or nut-driver
  - sealant (resistant to propane/LP gas, not provided)
1. Open lower louver door panel by gently pulling forward.
  2. Route flexible gas line (provided by installer) from equipment shutoff valve to fireplace. Route flexible gas supply line through one of the access holes on side of fireplace.
  3. Attach flexible gas line from gas supply to control valve (see Figure 32).
  4. Check all gas connections for leaks. See *Checking Gas Connections*.

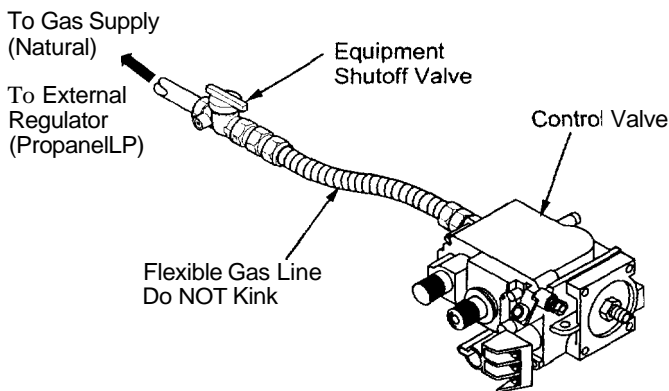


Figure 32 - Connecting Flexible Gas Line to Millivolt Valve

### CHECKING GAS CONNECTIONS

**WARNING:** Test all gas piping and connections for leaks after installing or servicing. Correct all leaks at once.

**WARNING:** Never use an open flame to check for a leak. Apply noncorrosive leakdetectionfluidtoall joints. Bubbles forming show a leak. Correct all leaks at once.

#### Pressure Testing Gas Supply Piping System

Test Pressures In Excess Of 1/2 PSIG (3.5 kPa)

1. Disconnect fireplace and its individual equipment shutoff valve from gas supply piping system. Pressures in excess of 1/2psig (3.5 kPa) will damage fireplace gas regulator.

2. Cap off open end of gas pipe where equipment shutoff valve was connected.
3. Pressurize supply piping system by either opening propane/LP supply tank valve for propane/LP gas fireplace or opening main gas valve located on or near gas meter for natural gas fireplace, or using compressed air.
4. Check all joints of gas supply piping system. Apply noncorrosive leak detection fluid to all joints. Bubbles forming show a leak. Correct all leaks at once.
5. Reconnect fireplace and equipment shutoff valve to gas supply. Check reconnected fittings for leaks.

Test Pressures **Equal To or Less Than 1/2 PSIG (3.5kPa)**

1. Close equipment shutoff valve (see Figure 33).
2. Pressurize supply piping system by either opening propane/LP supply tank valve for propane/LP gas fireplace or opening main gas valve located on or near gas meter for natural gas fireplace, or using compressed air.
3. Check all joints from propane/LP supply tank or gas meter to equipment shutoff valve (see Figure 34, for propane/LP or Figure 35, page 21, for natural gas). Apply noncorrosive leak detection fluid to all joints. Bubbles forming show a leak. Correct all leaks at once.

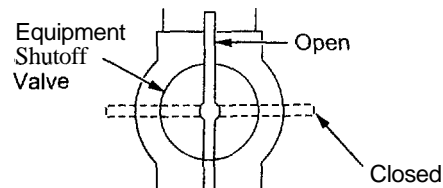


Figure 33 - Equipment Shutoff Valve

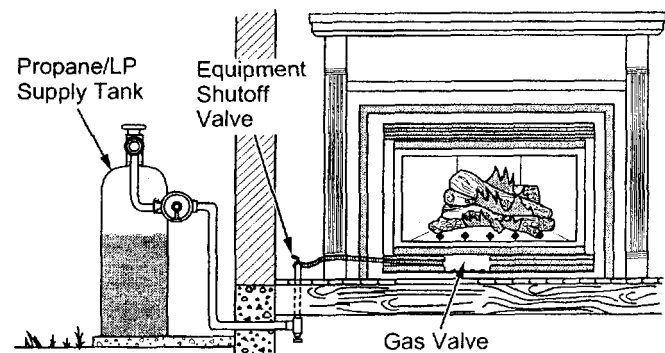
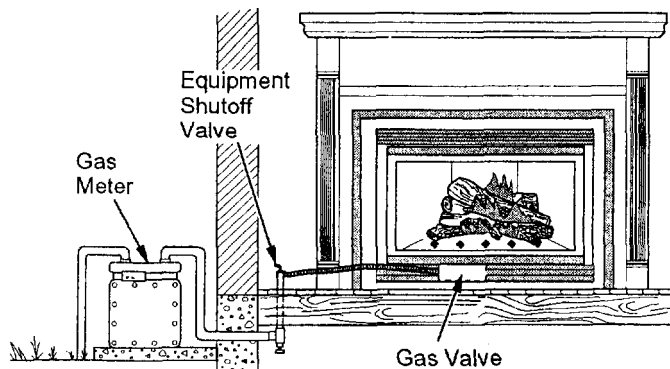


Figure 34 - Checking Gas Joints for Propane/LP Gas Fireplace

## FIREPLACE INSTALLATION

### Continued



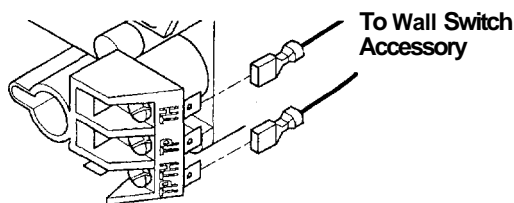
**Figure 35- Checking Gas Joints for Natural Gas Fireplace**

### Pressure Testing Fireplace Gas Connections

1. Open equipment shutoff valve (see Figure 33, page 20).
2. Open propane/LP supply tank valve for propane/LP fireplace or main gas valve located on or near gas meter for natural gas fireplace.
3. Make sure control knob of fireplace is in the OFF position.
4. Check all joints from equipment shutoff valve to gas valve (see Figure 34 for propane/LP or Figure 35 for natural gas). Apply noncorrosive leak detection fluid to all joints. Bubbles forming show a leak. Correct all leaks at once.
5. Light fireplace (see *Operating Fireplace*, pages 25 through 27). Check all other internal joints for leaks.
6. Turn off fireplace (see *To Turn Off Gas to Appliance*, page 25).

### INSTALLING OPTIONAL WALL MOUNT SWITCH - GWMS2

1. Connect one terminal of 25 ft. wire for the wall switch to the TPTH terminal on the valve. Connect remaining wire terminal to the TH terminal on the valve. Make sure that the wire terminals are in the positions on the unit as pictured in Figure 36. If wires are not connected as shown the switch will not work.



**Figure 36 - Connecting Wall Switch to Control Valve**

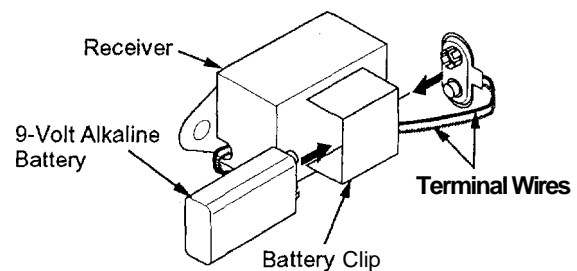
2. Route the 25 ft. wire through openings provided on the sides of the burner system to a convenient location to mount your switch.
3. Connect one bare wire end to each of the terminals of the GWMS2 wall switch.
4. Install the wall switch and cover in the wall.

### INSTALLING OPTIONAL WIRELESS HAND-HELD REMOTE CONTROL - (C)GHRCB AND (C)GHRCTB SERIES

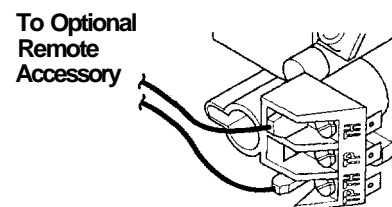
**NOTICE: Use only alkaline batteries (not included).**

#### Installing Remote Receiver

1. Open bottom louver and locate the switch bracket on the left.
2. Unscrew the switch bracket. Lean bracket forward so you are able to access the back of the remote receiver.
3. Locate the battery clip mounted on the back of the receiver. Slide a 9-volt alkaline battery (not included) through the clip (see Figure 37).
4. Attach the terminal wires to the battery.
5. Remove wire from TH to TPTH on control valve (see Figure 37).
6. Connect wires from receiver to TH and TPTH to control valve (see Figure 38).
7. Replace the switch bracket.



**Figure 37- Attaching Alkaline Battery to Receiver**



**Figure 38- Control Valve Terminals**

## REPLACE INSTALLATION

Installing Optional Wireless Hand-Held Remote Control - (C)GHRCB and (C)GHRCTB Series  
Removing/Replacing Glass Door

# FIREPLACE INSTALLATION

Continued

## Installing 9-Volt Alkaline Battery in Hand-Held Remote Control Unit

1. Remove battery cover on back of remote control unit.
2. Attach terminal wires to a 9-volt alkaline battery (not included). Place battery into the battery housing.
3. Replace battery cover onto remote control unit.

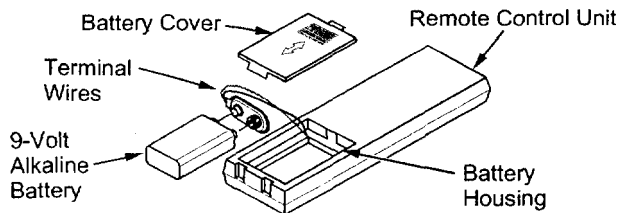


Figure 39 - Installing Alkaline Battery in Hand-Held Remote Control Unit ((C)GHRCB)

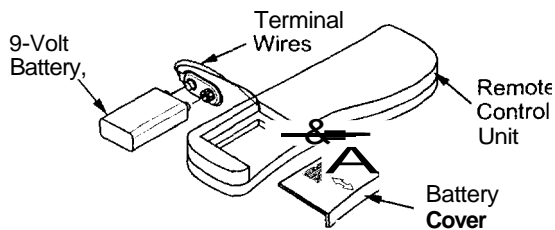


Figure 40 - Installing Battery in Hand-Held Remote Control Unit ((C)GHRCTB Series)

## REMOVING/REPLACING GLASS DOOR

**CAUTION:** Do not operate this fireplace with a broken glass door panel or without the glass door panel securely in place. For replacement part information see *Replacement Parts*, page 36.

**CAUTION:** Wear gloves and safety glasses while handling or removing broken glass. Do not remove if glass is hot. Keep children and pets away from glass.

**WARNING:** If fireplace has been running, turn off and unplug fireplace. Let cool before removing glass door or louvers.

## Removing Louver Panels

Remove the top and bottom louver panels by simultaneously pulling both top end spring latches towards the center of the appliance until they are disengaged from the locating holes (see Figure 41). Repeat for bottom spring latches and pull the louvers outward. To install or replace items removed, simply reverse the procedures above.

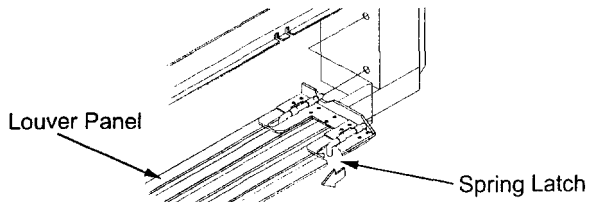


Figure 41 - Removing Louver Panel

## Removing Glass Doors

If replacement of glass is necessary, the entire assembly, glass and frame, must be replaced. If glass is broken, wear gloves and tape the remaining fragments onto the frame.

1. Remove screen assembly by pushing the rod either left or right and then down and forward to remove screen/rod assembly from the firebox. Set assembly aside.
2. Lift up on latches to unlock. There are two on top of firebox and two below firebox that hold glass door in place (see Figure 42).
3. While holding glass door to prevent it from falling and causing injury, remove the five screws from the hinge located on the left side of door frame assembly (see Figure 42).
4. Remount the new frame at the hinge with five new screws before closing door. This will ensure seating of the gasket.

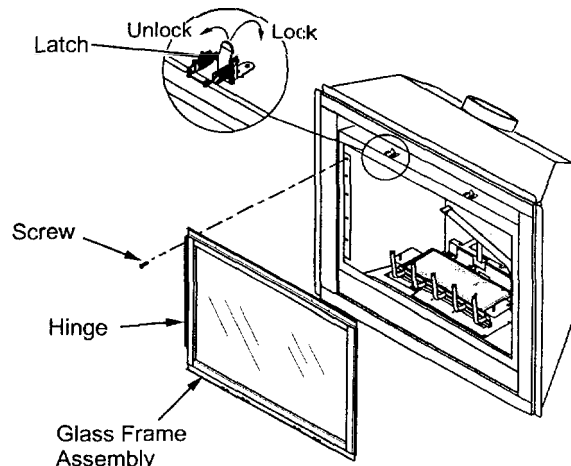


Figure 42 - Removing/Replacing Glass Door

For more information, visit [www.desatech.com](http://www.desatech.com)



## FIREPLACE INSTALLATION

### Continued

5. Close glass door frame. Lock latches by placing the bar under the tab on door and pushing down and **back** on latch (see Figure 42).
6. Replace screen/rod assembly by reversing step 1.
7. Replace louvers by reversing procedure under *Removing Louver Panels*, page 22.

### Cleaning Glass Door

See *Cleaning and Maintenance* on page 28

### INSTALLING OPTIONAL BRICK LINER MODELS BL36DA(SA) AND BL36DHA(SA)

**⚠ WARNING:** If fireplace has been running, turn off and unplug fireplace. Let cool before installing brick liner.

This brick liner kit is optional. You may purchase brick liner from your local retailer or see *Accessories*, page 39.

**⚠ CAUTION:** Always handle brick panels with two hands. Do not force brick panels into place. Excessive force will break brick panels.

1. Remove top and bottom louvers to allow access to door latches.
2. Unlock door latches and open glass door. See *Removing/Replacing Glass Door*, steps 1 and 2 on page 22.
3. If installing brick liner in new fireplace, go to step 4. If installing brick liner in an existing fireplace, carefully remove logs, lava rock, and ember material.
4. Remove three screws from deflector shield on the inside top of firebox. Set shield and screws aside.
5. Install rear brick panel first. Rest bottom edge of panel on back edge of grate (see Figure 43).
6. Install left side brick panel by sliding it between the grate and the side of the firebox (see Figure 44).
7. Install the right brick panel using the same method described.
8. Replace deflector shield using screws removed in step 4.
9. Follow instructions to install logs, lava rock, and ember material.
10. Close glass door and lock latches on top and bottom of door and replace screen. See *Removing/Replacing Glass Door*, steps 5 and 6.
11. Close top and bottom louvers.

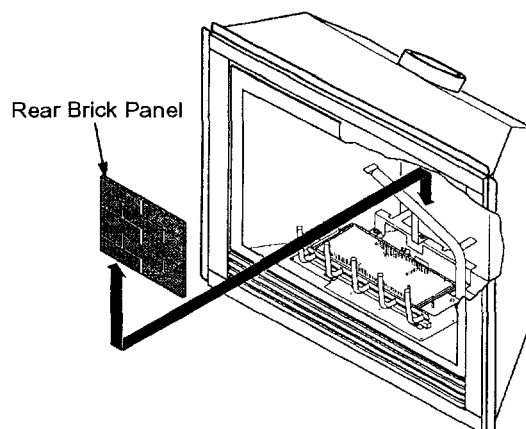


Figure 43 - Installing Rear Brick Panel

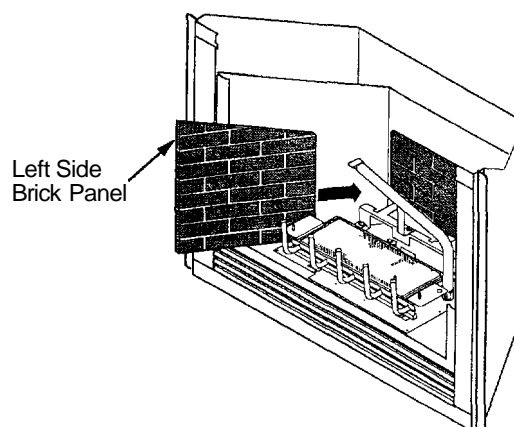


Figure 44 - Installing Side Brick Panels

## FIREPLACE INSTALLATION

*Continued*

### INSTALLING LOGS, LAVA ROCK AND GLOWING EMBERS

Each log is marked with a number. These numbers will help you identify the log when installing. It is very important to install these logs exactly as instructed. Do not modify logs. Only use logs supplied with fireplace.

Open louvers, remove screen, unlock door latches, and open glass door. See *Removing/Replacing Glass Door*, steps 1 and 2 on page 22. Install logs according to instructions for fireplace model numbers.

1. Place log #1 (base log), onto pin on left front side of grate as shown in Figure 45.
2. Rest left side of log #2 (front log) onto top of log #1. Place right side of log onto second pin located on right side of grate (see Figure 46).
3. Place log #3 (rear log) onto pins on rear of grate as shown in Figure 47.
4. Place log #4 (crossover log) onto pins from both logs #2 and #3 as shown in Figure 48.
5. Place log #5 (top log) onto right pin of front log (#2) and the smooth surface of crossover log (#4) as shown in Figure 49. Make sure it is seated properly.
6. Place log #6 (left log) onto left pin of front log (#2) and the smooth surface of rear log (#3) as shown in Figure 50. Make sure it is seated properly.

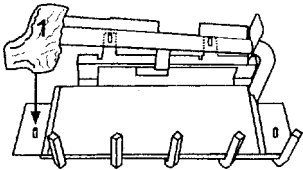


Figure 45 - Installing Log No. 1

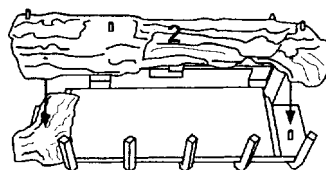


Figure 46 - Installing Log No. 2

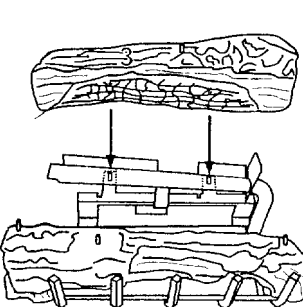


Figure 47 - Installing Log No. 3

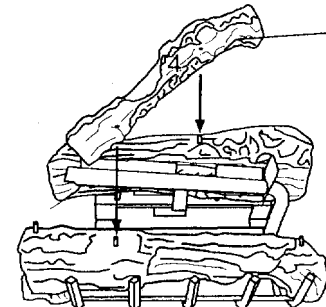


Figure 48 - Installing Log No. 4

7. Place lava rock along sides and front of firebox bottom in areas that are visible only. It is not necessary to use all of the lava rock provided.

**NOTICE: Do not put lava rock on burner or under burner. Placing lava rock on burner will cause performance problems.**

8. Pull ember material apart into pieces no larger than a dime. Place these pieces loosely and sparingly directly onto the exposed section of the front burner and along the space between the burner and grate prongs (see Figure 51). This will create the glowing ember appearance as the flame touches the ember material. Do not block air slots by using too much ember material in one area. It is not necessary to use all of the ember material provided.
9. Close glass door, lock door latches, replace screen, and close louvers (see *Removing/Replacing Glass Door*, steps 5 through 7 on page 23).

**WARNING: The glass door must be securely in place before running this fireplace. Do not run this fireplace if glass is missing or broken.**

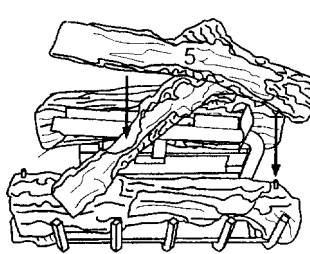


Figure 49 - Installing Log No. 5

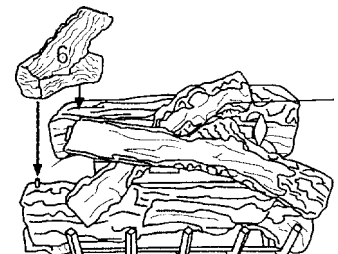


Figure 50 - Installing Log No. 6

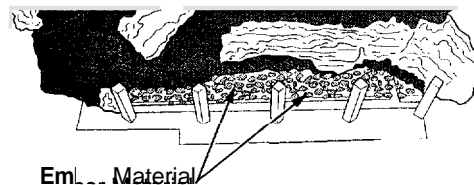


Figure 51 - Placing Ember Material on Burner

For more information, visit [www.desatech.com](http://www.desatech.com)

## OPERATING FIREPLACE

### FOR YOUR SAFETY READ BEFORE LIGHTING



**WARNING:** If you do not follow these instructions exactly, a fire or explosion may result causing property damage, personal injury or loss of life.


- This appliance has a pilot which must be lighted by hand. When lighting the pilot, follow these instructions exactly.
- BEFORE LIGHTING** smell all around the appliance area for gas. Be sure to smell next to the floor because some gas is heavier than air and will settle on the floor.

#### WHAT TO DO IF YOU SMELL GAS

- Do not try to light any appliance.
  - Do not touch any electric switch; do not use any phone in your building.
  - Immediately call your gas supplier from a neighbor's phone. Follow the gas supplier's instructions.
- Use only your hand to push in or turn the gas control knob. Never use tools. If the knob will not push in or turn by hand, don't try to repair it, call a qualified service technician. Force or attempted repair may result in a fire or explosion.
  - Do not use this appliance if any part has been under water. Immediately call a qualified service technician to inspect the appliance and to replace any part of the control system and any gas control which has been under water.

### LIGHTING INSTRUCTIONS

- STOP!** Read the safety information above.
- Open lower louver panel.
- Turn off all electric power to the fireplace.
- Push in **gas** control knob slightly and turn clockwise  to "OFF".
- Wait live (5) minutes to clear out any gas. Then smell for gas, including near the floor. If you smell gas, **STOP!** Follow "B" in the safety information above. If you don't smell gas, go to the next step.
- The pilot is located by the main burner and should not require accessing for lighting.
- Turn gas control knob counterclockwise  to "PILOT".
- Push in gas control knob all the way and hold. Immediately light the pilot by repeatedly depressing the piezo spark ignitor until a flame appears. Continue to hold for about one (1) minute after the pilot is lit. Release gas control knob and it will pop back. Pilot should remain lit. If it goes out, repeat steps 5 through 8.
  - If gas control knob does not pop up when released, stop and immediately call your service technician or gas supplier.
  - If the pilot will not stay lit after several tries, turn the gas control knob to "OFF" and call your service technician or gas supplier.

- Turn on all electric power to the fireplace.
- Turn gas control knob counterclockwise  to "ON".
- This valve is **equipped** with a HI/LO feature. Set fireplace input as desired.
- Close lower louver panel.

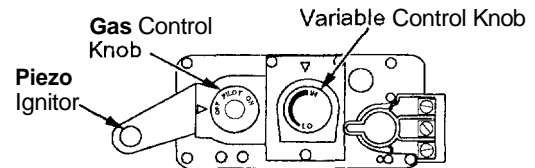




Figure 52- Control Valve

### TO TURN OFF GAS TO APPLIANCE

- Open lower louver panel.
- Set selector switch in the OFF position to prevent draining battery.
- Turn off all electrical power to the appliance if service is to be performed.
- Push in gas control knob slightly and turn clockwise  to "OFF".
- Close lower louver panel.

#### Shutting Off Burners Only (pilot stays lit)

You may shut off the burners and keep the pilot lit by doing one of the following:

- Turn gas control knob clockwise  to the PILOT position.
- Set selector switch in the OFF position.

### MANUAL LIGHTING PROCEDURE

- Remove glass door (see *Removing/Replacing Glass Door*, pages 22 and 23).
- Follow steps 1 through 8 under Lighting Instructions.
- Depress gas control knob and light pilot with match.
- Keep gas control knob pressed in for 30 seconds after lighting pilot. After 30 seconds, release gas control knob. Follow steps 10 through 14 under *Lighting Instructions*.
- Replace glass door (see *Removing/Replacing Glass Door*, pages 22 and 23).

## OPERATING FIREPLACE

*Continued*

### OPTIONAL HAND-HELD REMOTE OPERATION

Note: All remote control accessories must be purchased separately (see **Accessories**, page 39). Follow instructions included with the remote control.

**NOTICE:** You must light the pilot before using the hand-held remote control unit. See Lighting Instructions on page 25.

- After lighting, let pilot flame burn for about one minute. Turn control knob to ON position. Adjust flame adjustment knob anywhere between HI and LO. Slide the selector switch to the REMOTE position (see Figure 53). *Note:* The burner may light if hand-held remote was on when selector switch was last turned off. You can now turn the burner on and off with the hand-held remote control unit.

**IMPORTANT:** Do not leave the selector switch in the REMOTE or ON position when the pilot is not lit. This will drain the battery.

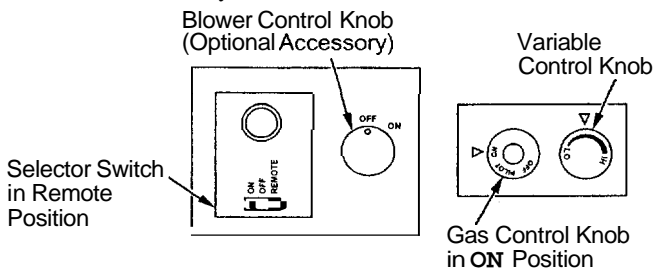


Figure 53- Setting the Selector Switch, Gas Control Knob, and Variable Control Knob for Remote Operation

### ON/OFF SERIES (MODELS GHRCB AND CGHRCTB)

Hold the control button on the hand-held remote until burner turns on. Hold the control button again until burner turns off (see Figure 54).

**TO LOCK** press both buttons on hand-held remote control until light stops flashing. Hand-held remote control is now locked. If the fire is on it will be turned off automatically. In the locked state, the light will not light up when any button is pressed.

**TO UNLOCK** press both buttons together on hand-held remote control until the light stops flashing. The hand-held remote is now unlocked.

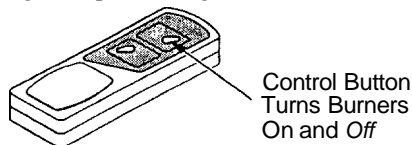


Figure 54 - On/Off Hand-Held Remote Control Unit (C) GHRCB

### THERMOSTAT SERIES (MODELS GHRCTB AND CGHRCTB)

The hand-held remote can be operated using either the manual mode (MANU) or thermostatic mode (AUTO) (see Figure 55). To select Fahrenheit/Centigrade mode display, carefully press the °C/°F mode button with the end of a paper clip or similar blunt object.

#### Manual Mode

- Press the POWER and LOCK buttons together to turn on the hand-held remote control.
- Press the MANU button to turn on the fireplace.
- Press the POWER and LOCK buttons together to turn off the fireplace.

#### Auto (Thermostatic) Mode

- Press the POWER and LOCK buttons together to turn on the hand-held remote control.
- Press AUTO button to select this mode.
- Set the desired room temperature by pressing the TEMP + or - buttons.
- Press the POWER and LOCK buttons together to turn off the fireplace.

**Note:** Do not leave the hand-held remote in the AUTO mode close to the fireplace. The radiant heat from the fireplace will turn off the fireplace. Ideally, place the hand-held remote in the center of the room facing towards the fireplace.

Note: Do not hold the hand-held remote for a long time. Body temperature will affect its operation in the AUTO mode.

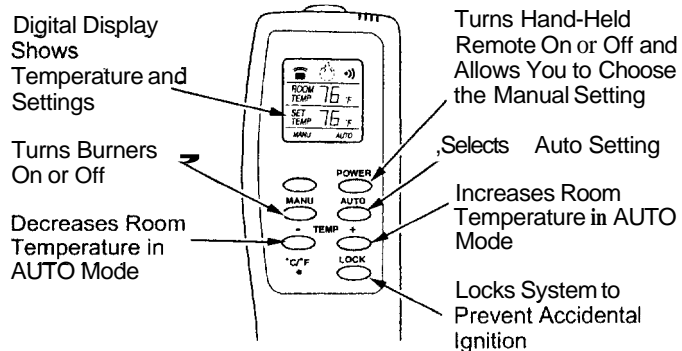


Figure 55- Thermostat Hand-Held Remote Control Unit (C) GHRCTB

#### Safety Features

When away from home for an extended period of time or as a child safety feature to prevent accidental ignition of the fireplace, the receiver ON/OFF/REMOTE switch should be in the OFF position.

For more information, visit [www.desatech.com](http://www.desatech.com)

## OPERATING FIREPLACE Continued

### Auto Shutoff Feature

1. If the average room temperature exceeds 82 degrees Fahrenheit (28 degrees Centigrade), the hand-held remote control will perform a safety override and shut the fireplace off. This feature is not available in the **MANU** mode.
2. The receiver continuously receives signals from the hand-held remote to control the room temperature. If the hand-held remote is misplaced, obstructed, or for any reason cannot transmit to the receiver, the receiver will shut off the fireplace after 8 minutes.

### Key Pad Lock Feature

This feature allows the user to lock/unlock the keypad on the hand-held remote in the **MANU** or **AUTO** mode to prevent inadvertent operation (i.e. children operating the hand-held remote control, etc.). The keypad is locked in either on or off. Press the **POWER** and **LOCK** buttons together to turn the unit on or off.

## OPERATING OPTIONAL GWMT1 WALL MOUNTED THERMOSTAT

**WARNING:** Do not connect the thermostat to a power source. Electrical shock and/or a fire hazard will occur.

Light the fireplace as instructed in *Lighting Instructions* on page 26. Set wall thermostat to desired temperature.

This thermostat has been electronically calibrated at the factory and requires no adjustment or leveling.

Upon installation, the thermostat must be allowed to stabilize at room temperature for a minimum of 30 minutes for proper operation.

To turn the fireplace off, adjust thermostat to the lowest setting and turn the gas control knob back to **PILOT**. The pilot will remain lit.

**IMPORTANT:** To turn the pilot off, turn the gas control knob on the heater to the **OFF** position.

## OPERATING OPTIONAL BLOWER ACCESSORY

Locate the blower controls by opening the lower louver panel on the fireplace. Blower controls are located on the left side of the switch bracket to the left just inside the louver panel.

The BK manual blower and the BKT thermostatically-controlled blower have an **ON** setting and an **OFF** setting. The blower will only run when the switch is in the **ON** position. In the **OFF** position, the blower will not operate.

**Note for BKT Only:** If you are using BKT blower with optional thermostat (wall mounted or remote control) for the fireplace, your fireplace and blower will not turn on and off at the same time. The fireplace may run for several minutes before the blower turns on. After the heater modulates to the pilot position, the blower will continue to run. The blower will shut off after the firebox temperature decreases.

The blower helps distribute heated air from the fireplace. Periodically check the louvers of the firebox and remove any dust, dirt, or other obstructions that will hinder the flow of air.

## INSPECTING BURNERS

Check pilot flame pattern and burner flame patterns often.

### PILOT ASSEMBLY

The pilot assembly is factory preset for the proper flame height. Alterations may have occurred during shipping and handling. Call a qualified service person to readjust the pilot if necessary.

The height of the thermopile must be  $3/8"$  to  $1/2"$  above the pilot flame as shown in Figure 56. The thermocouple must be at a height of about  $1/8"$  above the pilot flame. The flame from the pilot burner must extend beyond both the thermocouple and thermopile.

If your pilot assembly does not meet these requirements:

- turn fireplace off (see *To Turn Off Gas to Appliance*, page 25)
- see *Troubleshooting*, pages 29 through 31

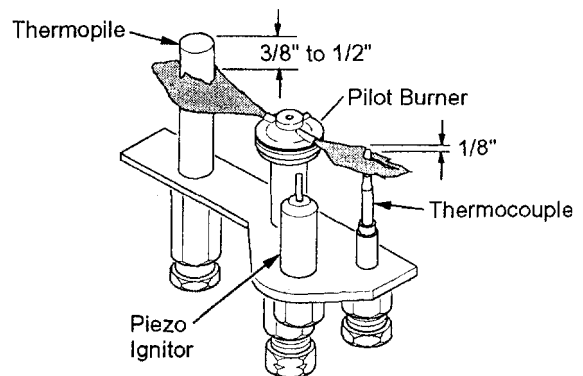


Figure 56- Pilot Assembly

### BURNER FLAME PATTERN

Burner flames will be steady; not lifting or floating. Flame patterns will be different from unit to unit and will vary depending on installation type and weather conditions.

If the vent configuration is installed incorrectly, the flames will lift or "ghost". This can be dangerous. Inspect the flames after installation to ensure proper installation and performance.

## INSPECTING BURNERS

### Continued

Figure 57 shows a typical flame pattern.

If burner flame pattern differs from that described:

- turn fireplace off (see *To Turn Off Gas to Appliance*, page 25)
- see *Troubleshooting*, pages 29 through 31

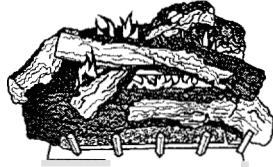


Figure 57 - Typical Flame Pattern

## CLEANING AND MAINTENANCE

**WARNING:** Turn off fireplace and let cool before cleaning.

**CAUTION:** You must keep control areas, burners, and circulating air passageways of fireplace clean. Inspect these areas of fireplace before each use. Have fireplace inspected yearly by a qualified service person. Fireplace may need more frequent cleaning due to excessive lint from carpeting, bedding material, pet hair, etc.

### GLASS DOOR

**WARNING:** Handle glass door panel with care. Do not strike, slam, or otherwise abuse glass. Do not operate fireplace with the glass door removed, cracked, or broken.

**WARNING:** Do not use abrasive cleaners as this may damage glass. Use a nonabrasive household glass cleaner to clean glass. Do not clean glass when hot.

Glass must be cleaned periodically. During start-up it is normal for condensation to form on the inside of the glass causing lint, dust, and other airborne particles to cling to the glass surface. During initial start-up a slight film may form on the glass due to paint curing. The glass should be cleaned several times with a non-ammonia, non-abrasive household cleaner and warm water after the first two weeks of operation. Thereafter, clean the glass two or three times during each heating season, depending on the usage and circumstances present. Refer to *Removing/Replacing Glass Door*, pages 22 and 23 of this manual when removing glass door for cleaning.

**WARNING:** Only parts supplied by the manufacturer should be used when replacing broken or damaged glass door panel (see *Replacement Parts*, page 36). This glass door panel is a complete unit. No substitute materials may be used.

**CAUTION:** Wear gloves and safety glasses while handling or removing broken glass. Do not remove if glass is hot. Keep children and pets away from glass.

If glass has been broken, carefully remove glass door (see *Removing/Replacing Glass Door*, pages 22 and 23). Vacuum all glass pieces with a shop vac.

**CAUTION:** Do not vacuum if pieces are hot.

Use only the tempered glass door replacement intended for this fireplace (see *Replacement Parts*, page 36 for detail on ordering). No substitutions may be made. See *Removing/Replacing Glass Door*, pages 22 and 23 for instructions for replacing glass door.

**WARNING:** Do not operate fireplace with the glass door removed, cracked, or broken.

### PILOT AND BURNERS

- Remove ember material before cleaning burners and replace when cleaning is complete.
- Burner and controls should be cleaned with compressed air to remove dust, dirt, or lint.
- Use a vacuum cleaner or small, soft bristled brush to remove excess dust, dirt, or lint.

### LOGS

- If you remove logs for cleaning, refer to *Installing Logs, Lava Rock, and Glowing Embers*, page 24, to properly replace logs.
- Use a vacuum cleaner to remove any carbon buildup on logs.
- Replace log(s) if broken. See *Replacement Parts* on page 36.
- Replace ember material periodically as needed. See *Replacement Parts* on page 36.

### VENTING SYSTEM

Conduct annual inspection of the venting system following these guidelines:

1. Check areas of venting system that are exposed to the weather for corrosion (rust spots or streaks and, in extreme cases, holes). Have these items replaced immediately by a qualified service person.
2. Remove the vent cap and shine a flashlight into the vent. Remove any foreign material.
3. Check for evidence of excessive condensation. Continuous condensation can cause corrosion of caps, pipes, and fittings and can be caused by having excessive lateral runs, too many elbows, or exterior portions of the system being exposed to cold weather.
4. Inspect joints to verify that no pipe section or fitting has been disturbed and loosened. Check mechanical supports such as wall straps for rigidity.

## TROUBLESHOOTING

*Note:* For additional help, visit DESA's technical service web site at [www.desatech.com](http://www.desatech.com).

*Note:* All troubleshooting items are listed in order of operation.

**⚠ WARNING:** Turn off heater and let cool before servicing. Only a qualified service person should service and repair heater.

**⚠ CAUTION:** Never use a wire, needle, or similar object to clean pilot. This can damage pilot unit.

OBSERVED PROBLEM	POSSIBLE CAUSE	REMEDY
When ignitor button is pressed, there is no spark at pilot	<ol style="list-style-type: none"> <li>Ignitor electrode not connected to ignitor cable</li> <li>Ignitor cable pinched or wet</li> <li>Piezo ignitor nut is loose</li> <li>Broken ignitor cable</li> <li>Bad piezo ignitor</li> <li>Ignitor electrode broken</li> <li>Ignitor electrode positioned wrong</li> </ol>	<ol style="list-style-type: none"> <li>Reconnect ignitor cable</li> <li>Free ignitor cable if pinched by any metal or tubing. Keep ignitor cable dry</li> <li>Tighten nut holding piezo ignitor. Nut is located behind the mounting bracket</li> <li>Replace ignitor cable</li> <li>Replace piezo ignitor</li> <li>Replace pilot assembly</li> <li>Replace pilot assembly</li> </ol>
When ignitor button is pressed, there is spark at pilot but no ignition	<ol style="list-style-type: none"> <li>Gas supply turned off or equipment shutoff valve closed</li> <li>Gas control knob not in PILOT position</li> <li>Gas control knob not pressed in while in PILOT position</li> <li>Air in gas lines when installed</li> <li>Depleted gas supply (propane/LP models only)</li> <li>Pilot is clogged</li> <li>Gas regulator setting is not correct</li> </ol>	<ol style="list-style-type: none"> <li>Turn on gas supply or open equipment shutoff valve</li> <li>Turn gas control knob to PILOT position</li> <li>Press in gas control knob while in PILOT position</li> <li>Continue holding down control knob. Repeat igniting operation until air is removed</li> <li>Contact local propane/LP gas company</li> <li>Clean pilot (see <i>Cleaning and Maintenance</i>, page 28) or replace pilot assembly</li> <li>Replace gas control</li> </ol>
Pilot lights but flame goes out when control knob is released	<ol style="list-style-type: none"> <li>Gas control knob not fully pressed in</li> <li>Gas control knob not pressed in long enough</li> <li>Equipment shutoff valve not fully open</li> <li>Pilot flame not touching thermocouple, which allows thermocouple to cool, causing pilot flame to go out. This problem could be caused by one or both of the following:               <ol style="list-style-type: none"> <li>Low gas pressure</li> <li>Dirty or partially clogged pilot</li> </ol> </li> <li>Thermocouple connection loose at control valve</li> <li>Thermocouple damaged</li> <li>Control valve damaged</li> </ol>	<ol style="list-style-type: none"> <li>Press in gas control knob fully</li> <li>After pilot lights, keep gas control knob pressed in 30 seconds</li> <li>Fully open equipment shutoff valve</li> <li> <ol style="list-style-type: none"> <li>Contact local natural or propane/LP gas company</li> <li>Clean pilot (see <i>Cleaning and Maintenance</i>, page 28) or replace pilot assembly</li> </ol> </li> <li>Hand tighten until snug, then tighten 1/4 turn more</li> <li>Replace pilot assembly</li> <li>Replace control valve</li> </ol>

## TROUBLESHOOTING

*Continued*

OBSERVED PROBLEM	POSSIBLE CAUSE	REMEDY
Burner does not light after pilot is lit	<ol style="list-style-type: none"> <li>1. Burner orifice clogged</li> <li>2. Inlet gas pressure is too low</li> <li>3. Thermopile leads disconnected or improperly connected</li> <li>4. Thermopile is defective</li> </ol>	<ol style="list-style-type: none"> <li>1. Clean burner (see <i>Cleaning and Maintenance</i>, page 28) or replace burner orifice</li> <li>2. Contact local propane/LP or natural gas company</li> <li>3. Reconnect leads</li> <li>4. Replace thermopile</li> </ol>
Delayed ignition burner	<ol style="list-style-type: none"> <li>1. Manifold pressure is too low</li> <li>2. Burner porting or orifice clogged</li> </ol>	<ol style="list-style-type: none"> <li>1. Contact local propane/LP or natural gas company</li> <li>2. Clean burner (see <i>Cleaning and Maintenance</i>, page 28) or replace burner orifice</li> </ol>
Burner backfiring during combustion	<ol style="list-style-type: none"> <li>1. Burner orifice is clogged or damaged</li> <li>2. Damaged burner</li> <li>3. Gas regulator defective</li> </ol>	<ol style="list-style-type: none"> <li>1. Clean burner (see <i>Cleaning and Maintenance</i>, page 28) or replace burner orifice</li> <li>2. Replace damaged burner</li> <li>3. Replace gas control</li> </ol>
Slight smoke or odor during initial operation	<ol style="list-style-type: none"> <li>1. Residues from manufacturing processes and logs curing</li> </ol>	<ol style="list-style-type: none"> <li>1. Problem will stop after a few hours of operation</li> </ol>
Heater produces a whistling noise when burner is lit	<ol style="list-style-type: none"> <li>1. Turning gas control knob to HI position when burner is cold</li> <li>2. Air in gas line</li> <li>3. Dirty or partially clogged burner orifice</li> </ol>	<ol style="list-style-type: none"> <li>1. Turn gas control knob to LO position and let warm up for a minute</li> <li>2. Operate burner until air is removed from line. Have gas line checked by local propane/LP or natural gas company</li> <li>3. Clean burner (see <i>Cleaning and Maintenance</i>, page 28) or replace burner orifice</li> </ol>
Glass soots	<ol style="list-style-type: none"> <li>1. Flame impingement on logs</li> <li>2. Debris around burner air mixer</li> </ol>	<ol style="list-style-type: none"> <li>1. Adjust the log set so that the flame does not excessively impinge on it</li> <li>2. Inspect the opening at the base of the burner to see that it is NOT packed with any type of material</li> </ol>
Fireplace produces a clicking/ticking noise just after burners are lit or shut off	<ol style="list-style-type: none"> <li>1. Metal expanding while heating or contracting while cooling</li> </ol>	<ol style="list-style-type: none"> <li>1. This is common. If noise is excessive, contact qualified service person</li> </ol>
Remote does not function	<ol style="list-style-type: none"> <li>1. Battery is not installed or battery power is low</li> </ol>	<ol style="list-style-type: none"> <li>1. Replace 9-volt batteries in receiver and remote control</li> </ol>



## TROUBLESHOOTING

*Continued*

- ⚠ WARNING: If you smelt gas**
- Shut off gas supply.
  - Do not try to light any appliance.
  - Do not touch any electrical switch; do not use any phone in your building.
  - Immediately call your gas supplier from a neighbor's phone. Follow the gas supplier's instructions.
  - If you cannot reach your gas supplier, call the fire department.

OBSERVED PROBLEM	POSSIBLE CAUSE	REMEDY
Fireplace produces unwanted odors	1. Gas leak. <b>See Warning statement above</b>	1. Locate and correct all leaks (see <i>Checking Gas Connections</i> , page 20)
Fireplace shuts off in use	1. High or gusting winds 2. Low line pressure 3. Pilot is partially clogged 4. Inner vent pipe leaking exhaust gasses into system 5. Glass too loose and air tight gasket leaks in comers after usage 6. Bad thermopile or thermocouple 7. Improper vent cap installation	1. Fireplace has been tested for up to 40mph winds. However, extreme conditions may occur. See <i>Lighting Instructions</i> on page 26 2. Contact local propane/L.P or natural gas company 3. Clean pilot (see <i>Cleaning and Maintenance</i> , page 28) 4. Locate and correct all leaks (see <i>Checking Gas Connections</i> , page 20) 5. Tighten glass 6. Replace faulty component 7. Check for proper installation and freedom from debris or blockage
Gas odor even when control knob is in OFF position	1. Gas leak. <b>See Warning statement above</b> 2. Control valve defective	1. Locate and correct all leaks (see <i>Checking Gas Connections</i> , page 20) 2. Replace control valve
Gas odor during combustion	1. Gas leak. <b>See Warning statement above</b>	1. Locate and correct all leaks (see <i>Checking Gas Connections</i> , page 20)
Dark residue on logs or inside of fireplace	1. Improper log placement 2. <del>Air</del> holes at burner inlet blocked 3. Burner flame holes blocked 4. Improper venting or excessive blockage 5. Excessive <b>amounts</b> of embers and pan material	1. Properly locate logs (see <i>Installing Logs, Lava Rock, and Glowing Embers</i> , pages 24 and 25) 2. Clean out air holes at burner inlets. Periodically repeat as needed 3. Remove blockage or replace burner 4. Have the vent system inspected, including the termination cap. Remove any restrictions or obstruction 5. Clear excess embers until a minimum gap of 1/2" remains under the grate

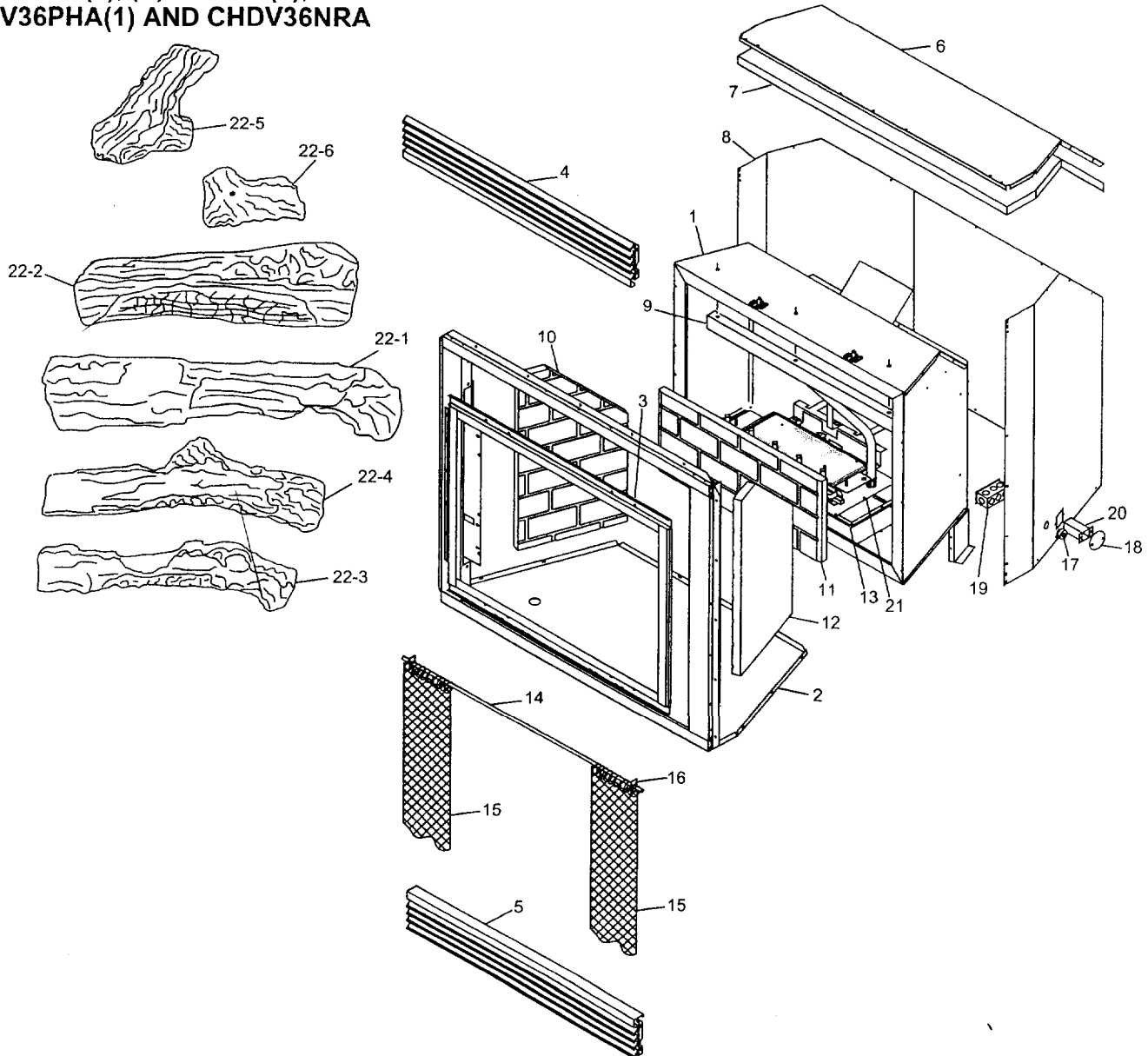
For more information, visit [www.desatech.com](http://www.desatech.com)



**ILLUSTRATED PARTS BREAKDOWN**  
Models (V)V36NA(1), (V)V36NSA(1), (V)V36NHA(1),  
(V)V36PA(1), (V)V36PSA(1), (V)V36PHA(1) and CHDV36NRA

# ILLUSTRATED PARTS BREAKDOWN

MODELS (V)V36NA(1),  
(V)V36NSA(1), (V)V36NHA(1),  
(V)V36PA(1), (V)V36PSA(1),  
(V)V36PHA(1) AND CHDV36NRA



For more information, visit [www.desatech.com](http://www.desatech.com)

## PARTS LIST

This list contains replaceable parts used in your fireplace. When ordering parts, follow the instructions listed under *Replacement Parts* on page 36 of this manual.

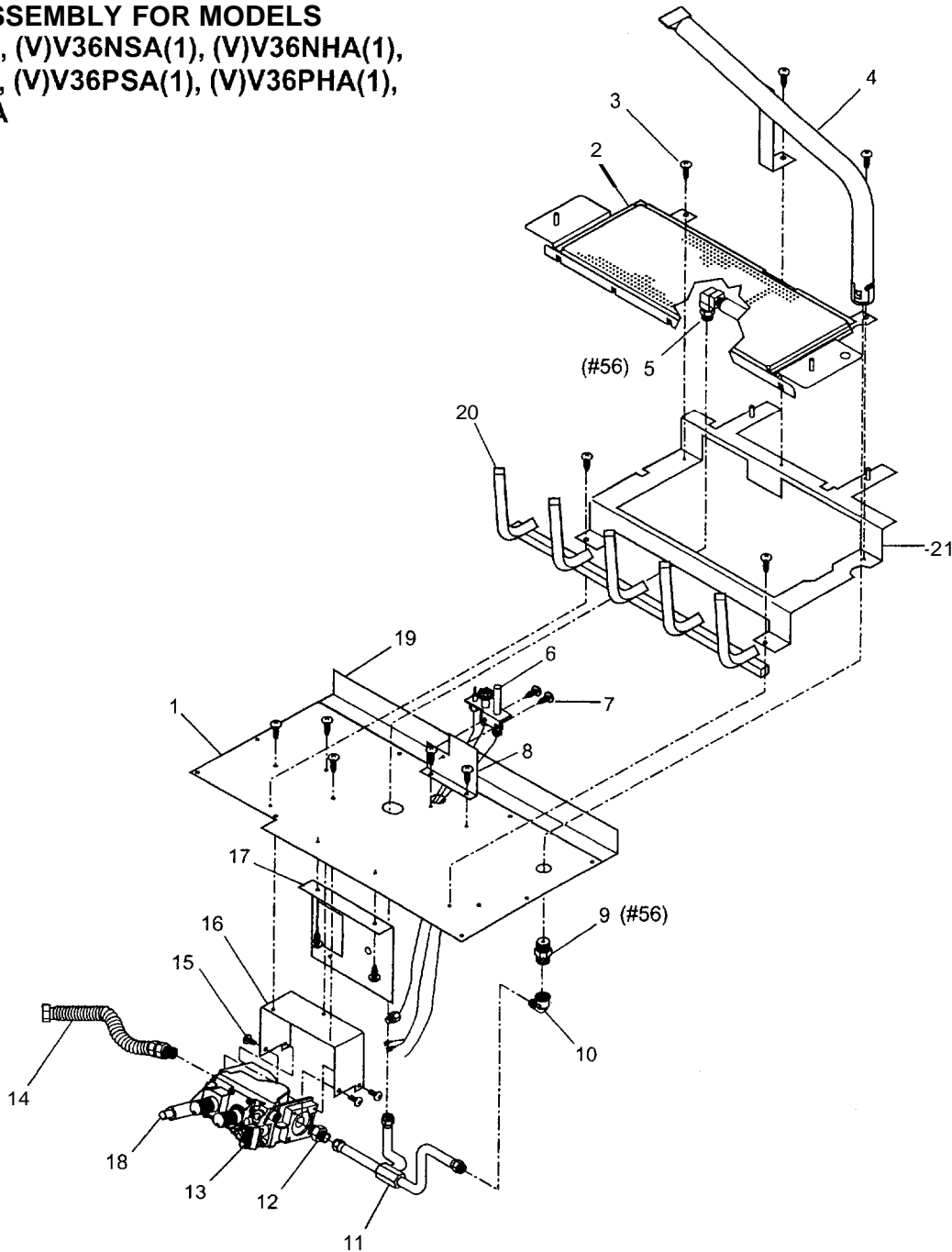
KEY NO.	(V)V36NA(1) (V)V36PA(1)	(V)V36NSA(1) (V)V36PSA(1)	(V)V36NHA(1) (V)V36PHA(1)	CHDV36NRA	DESCRIPTION	QTY
1	**	**	**	**	Firebox Assembly	1
2	**	**	**	**	Face Weldment	1
3	108010-01	108010-01	108010-01	108010-01	Door Assembly (V/CHDV Models Only)	1
	108010-02	108010-02	108010-02	—	Door Assembly (VV Models Only)	1
4	108011-01	108011-01	108011-01	108011-01	Top Louver Assy	1
5	108011-02	108011-02	108011-02	108011-02	Bottom Louver Assy	1
6	108015-01	108015-01	108015-01	108015-01	Fireplace Top	1
7	108016-01	108016-01	108016-01	108016-01	Fireplace Top Insulation	1
8		**	**	**	Fireplace Surround	1
9	109082-01	109082-01	109082-01	109082-01	Heat Shield	1
10		See Below	See Below	See Below	Left Refractory Brick Panel	1
11	—	See Below	See Below	See Below	Rear Refractory Brick Panel	1
12	—	See Below	See Below	See Below	Right Refractory Brick Panel	1
13	108076-01	108076-01	108076-01	108076-01	Burner Base Gasket	1
14	108719-01	108719-01	108719-01	108719-01	Screen Rod	1
15	12105	12105	12105	12105	Screen	2
16	11418	11418	11418	11418	Push-On Nut	2
17	14123	14123	14123	14123	Strain Relief	1
18	21171	21171	21171	21171	Gas Knock-Out Cover	2
19	24353	24353	24353	24353	Handy Box Assembly	1
20	24460	24460	24460	24460	Gas Conduit Assembly	1
21	108760-01	108760-01	108760-01	108760-01	Burner Assembly (Natural Gas)	1
	108760-02	108760-02	108760-02	108760-02	Burner Assembly (Propane/LP Gas) (See pages 38 and 39)	1
22	108032-01	108032-01	108032-01	108032-01	Log Set	1
22-1	109128-01	109128-01	109128-01	109128-01	Front Log (Log 1)	1
22-2	109129-01	109129-01	109129-01	109129-01	Rear Log (Log 2)	1
22-3	109130-01	109130-01	109130-01	109130-01	Crossover Log (Log 3)	1
22-4	109131-01	109131-01	109131-01	109131-01	Top Log (Log 4)	1
22-5	109132-01	109132-01	109132-01	109132-01	Left Log (Log 5)	1
22-6	109133-01	109133-01	109133-01	109133-01	Base Log (Log 6)	1
<b>PARTS AVAILABLE - NOT SHOWN</b>						
	25487	25487	25487	25487	Lava Rock/Bag Assy	1
	27253	27253	27253	27253	Notice Label	1
	55240	55240	55240	55240	Vent Label	1
	—	—	—	PCDM-36VA	Conversion Kit	1
<b>CHDV36NRA</b>						
	<b>V36NSA(1), V36PSA(1)</b>	<b>VV36NSA(1) VV36PSA(1)</b>	<b>V36NHA(1) V36PHA(1)</b>	<b>VV36NHA(1) VV36PHA(1)</b>	<b>DESCRIPTION</b>	<b>QTY</b>
	110989-02	110989-01	111215-02	111215-01	Left Refractory Brick Panel	1
	110991-02	110991-01	111217-02	111217-01	Rear Refractory Brick Panel	1
	110990-02	110990-01	111216-02	111216-01	Right Refractory Brick Panel	1

**ILLUSTRATED PARTS BREAKDOWN**

Models (V)V36NA(1), (V)V36NSA(1), (V)V36NHA(1),  
(V)V36PA(1), (V)V36PSA(1), (V)V36PHA(1), CHDV36NRA

**ILLUSTRATED PARTS  
BREAKDOWN**

**BURNER ASSEMBLY FOR MODELS**  
(V)V36NA(1), (V)V36NSA(1), (V)V36NHA(1),  
(V)V36PA(1), (V)V36PSA(1), (V)V36PHA(1),  
CHDV36NRA



For more information, visit [www.desatech.com](http://www.desatech.com)

## PARTS LIST

### BURNER ASSEMBLY FOR MODELS (V)V36NA(1), (V)V36NSA(1), (V)V36NHA(1), (V)V36PA(1), (V)V36PSA(1), (V)V36PHA(1), CHDV36NRA

This list contains replaceable parts used in your fireplace. When ordering parts, follow the instructions listed under Replacement Parts on page 36 of this manual.

KEY NO.	PART NUMBER	DESCRIPTION	QTY.
1	**	Burner Assembly Base	1
2	108759-01	Pan Burner Assembly	1
3	11165	Screw #10 x 518 MD TR BLK	12
4	108763-01	Tube Burner	1
5	104506-26	Pan Burner Orifice (Natural Gas)	1
	104506-20	Pan Burner Orifice (Propane/LP Gas)	1
6	108084-02	Pilot Assembly (Natural Gas)	1
	108084-03	Pilot Assembly (Propane/LP Gas)	1
7	11102	Screw #8-32 x 318 PPH Zinc	2
8	108755-01	Pilot Bracket	1
9	104506-25	Tube Burner Orifice (Natural Gas)	1
	14544	Tube Burner Orifice (Propane/LP Gas)	1
10	14528	Brass Elbow Fitting	1
11	14554	Tubing Assembly	1
12	14500	Brass Fitting	1
13	14389	Millivolt Valve (Natural Gas)	1
	14390	Millivolt Valve (Propane/LP Gas)	1
14	14253	Flexible Gas Line	1
15	11107	Screw #10-32 x 1/4 PPH Zinc	4
16	26808	Valve Bracket	1
17	26827	Switch Bracket	1
18	14261	Piezo Ignitor	1
19	110986-01	Air Baffle (Natural Gas)	2
	110986-02	Air Baffle (Propane/LP Gas)	2
20	108761-01	Grate Assembly	1
21	108754-01	Grate Base	1

\*\*Not a field replaceable part.

## REPLACEMENT PARTS

**Note:** Use only original replacement parts. This will protect your warranty coverage for parts replaced under warranty.

### PARTS UNDER WARRANTY

Contact authorized retailers of this product. If they can not supply original replacement part(s), call DESA's Customer Service Department at 1-866-672-6040.

When calling DESA, have ready

- your name
- your address
- model and serial numbers of your fireplace
- how fireplace was malfunctioning
- type of gas used (propane/LP or natural gas)
- purchase date

Usually, we will ask you to return the part to the factory.

### PARTS NOT UNDER WARRANTY

Contact authorized retailers of this product. If they can not supply original replacement part(s), call DESA at 1-866-672-6040 for referral information.

When calling DESA, have ready

- model number of your fireplace
- the replacement part number

## SPECIFICATIONS

	(V)V36NA(1)	CHDV36NRA	(V)V36PA(1)
Btu	18,000/ 26,000 Btu/hr	18,000 26,000 Btu/hr	17,500 25,000 Btu/hr
Gas Type	Natural	Natural	Propane/LP
Ignition	Piezo	Piezo	Piezo
Manifold Pressure	3.5" w.c.	3.5" w.c.	10.0" w.c.
Minimum Inlet Supply Pressure	5.5" w.c.	5.5" w.c.	11.0" w.c.
Dimension, Inches/mm (HxWxD)Fireplace (Actual size of firebox. Measurements do not include nailing flanges or standoffs).	36"x41"x21 1/8" 914x1041x 537 mm	36"x41"x21 1/8" 914x1041x 537 mm	36"x41"x21 1/8" 914x1041x 537 mm
Carton	38"x44"x22" 965x1118x 559 mm	38"x44"x22" 965x1118x 559 mm	38"x44"x22" 965x1118x 559 mm
Weight, lbs/kg*			
Fireplace	120 lbs/55 kg	180 lbs/82 kg	120 lbs/55 kg
Shipping	123 lbs/56 kg	183 lbs/83 kg	123 lbs/56 kg

\*For refractory lined models add 60 pounds for 36" models.

## SERVICE HINTS

### When Gas Pressure Is Too Low

- pilot will not stay lit
- burners will have delayed ignition
- fireplace will not produce specified heat
- propane/LP gas supply might be low (propane/LP units only)

You may feel your gas pressure is too low. If so, contact your local gas supplier.

## TECHNICAL SERVICE

You may have further questions about installation, operation, or troubleshooting. If so, contact DESA's Customer Service Department at 1-866-672-6040. When calling, please have your model and serial numbers of your heater ready.

You can also visit DESA's technical service web site at [www.desatech.com](http://www.desatech.com).

**For more information, visit [www.desatech.com](http://www.desatech.com)**

## OWNER'S REGISTRATION FORM

In order to provide better customer service for this and future purchases, we recommend that you register your product with us. You can register online at [www.desatech.com](http://www.desatech.com). If access to our website is not available to you, please complete this Owner's Registration Form and mail to the address on the back of this owner's manual. Please provide the following product information:

Brand: \_\_\_\_\_ (Comfort Glow, Vanguard, etc.)  
 Model: \_\_\_\_\_ (EFP33PR, VTGH33NR, etc.)  
 Date Purchased: \_\_\_\_\_ *Note: Keep receipt for warranty verification.*  
 Serial Number: \_\_\_\_\_ 7 or 9 digit number located on product or identification tag.  
 First Name: \_\_\_\_\_ Last Name: \_\_\_\_\_  
 Address: \_\_\_\_\_  
 City: \_\_\_\_\_ State: \_\_\_\_\_ Zip: \_\_\_\_\_ Country: \_\_\_\_\_  
 Home Phone: { \_\_\_\_\_  
 E-Mail: \_\_\_\_\_

Please answer the following questions to register your product with **DESA**:

1. Where will the product be used?  
 Living/Family Room  Office/Warehouse  Utility Shed/Outbuilding  Garage  Bedroom  Bathroom  Other
2. If you bought this product yourself, did you plan to purchase this type of product before going into the store?  Yes  No
3. Who selected the product?  Male  Female  Both
4. What is the population of your area?  Under 10,000  10,000 to 25,000  25,000 to 50,000  50,000 to 100,000  
 100,000 to 250,000  Over 250,000
5. What is your primary source of heat?  Propane (LP Gas)  Fuel Oil  Wood  Natural Gas  Electric  Other
6. How was the product installed?  Professional Installer  Self  Other
7. Cost of product excluding sales tax? \$ \_\_\_\_\_
8. Cost to install product? \$- \_\_\_\_\_
9. Type of store where product was purchased?  Hardware  Propane Dealer  Natural Gas/Utility Co.  Home Center/Builder's Supply  
 Fireplace or Hearth Shop  Farm Store  Other
10. What motivated you to buy this product?  Sudden Cold Weather  Replace Older Model  D.I.Y. Home Project  
 Emergency Back-Up Heat  Heater was on Sale  Energy Savings/High Efficiency  Construction Project  Other
11. How did you learn about this product brand?  Advertising  Relative or Friend  Store Display  Other \_\_\_\_\_
12. Level of Education of Purchaser:  Some High School  Completed High School  Completed College  Completed Graduate School
13. Age of Purchaser:  Under 20  20 - 29  30 - 39  40 - 49  50 - 59  60 or Over
14. Buyer's total annual household income:  Under \$15,000  \$15,000 to \$19,999  \$20,000 to \$34,999  \$35,000 to \$49,999  
 \$50,000 to \$74,999  \$75,000 to \$99,999  \$100,000 and Over
15. Store where product was purchased:  
 Name: \_\_\_\_\_  
 City: \_\_\_\_\_ State: \_\_\_\_\_

16. In choosing this product, how important were the following:

	Not Important	Somewhat Important	Very Important
Availability	<input type="radio"/>	<input type="radio"/>	<input type="radio"/>
Price	<input type="radio"/>	<input type="radio"/>	<input type="radio"/>
Brand Name	<input type="radio"/>	<input type="radio"/>	<input type="radio"/>
Overall Quality	<input type="radio"/>	<input type="radio"/>	<input type="radio"/>
Heat Output	<input type="radio"/>	<input type="radio"/>	<input type="radio"/>
Made in USA	<input type="radio"/>	<input type="radio"/>	<input type="radio"/>
Warranty	<input type="radio"/>	<input type="radio"/>	<input type="radio"/>
Local Service	<input type="radio"/>	<input type="radio"/>	<input type="radio"/>
Value for Price	<input type="radio"/>	<input type="radio"/>	<input type="radio"/>
Prior Brand Experience	<input type="radio"/>	<input type="radio"/>	<input type="radio"/>
Controls Location	<input type="radio"/>	<input type="radio"/>	<input type="radio"/>
Thermostat, Remote, or Manual Operation	<input type="radio"/>	<input type="radio"/>	<input type="radio"/>
Ease of Operation	<input type="radio"/>	<input type="radio"/>	<input type="radio"/>
Special Features	<input type="radio"/>	<input type="radio"/>	<input type="radio"/>
Salesperson's Recommendation	<input type="radio"/>	<input type="radio"/>	<input checked="" type="radio"/>
Friend/Relative's Recommendation	<input type="radio"/>	<input type="radio"/>	<input type="radio"/>
Portability	<input type="radio"/>	<input type="radio"/>	<input type="radio"/>
Quiet Operation	<input type="radio"/>	<input type="radio"/>	<input type="radio"/>

# WARRANTY INFORMATION

## KEEP THIS WARRANTY

Model _____
Serial No. _____
Date Purchased _____

Always specify model and serial numbers when communicating with the factory.

We reserve the right to amend these specifications at any time without notice. The only warranty applicable is our standard written warranty. We make no other warranty, expressed or implied.

### LIMITED WARRANTY DIRECT-VENT FIREPLACE

DESA warrants this product to be free from defects in materials and components for two (2) years from the date of first purchase, provided that the product has been properly installed, operated and maintained in accordance with all applicable instructions. To make a claim under this warranty the Bill of Sale or cancelled check must be presented.

This warranty is extended only to the original retail purchaser. This warranty covers the cost of part(s) required to restore this heater to proper operating condition and an allowance for labor when provided by a DESA Authorized Service Center. Warranty part(s) MUST be obtained through authorized retailers of this product and/or DESA who will provide original factory replacement parts. Failure to use original factory replacement parts voids this warranty. The heater MUST be installed by a qualified installer in accordance with all local codes and instructions furnished with the unit.

This warranty does not apply to parts that are not in original condition because of normal wear and tear, or parts that fail or become damaged as a result of misuse, accidents, lack of proper maintenance or defects caused by improper installation. Travel, diagnostic cost, labor, transportation and any and all such other costs related to repairing a defective heater will be the responsibility of the owner.

TO THE FULL EXTENT ALLOWED BY THE LAW OF THE JURISDICTION THAT GOVERNS THE SALE OF THE PRODUCT; THIS EXPRESS WARRANTY EXCLUDES **ANY** AND ALL OTHER EXPRESSED WARRANTIES AND LIMITS THE DURATION OF ANY AND ALL IMPLIED WARRANTIES, INCLUDING WARRANTIES OF MERCHANTABILITY AND FITNESS FOR A PARTICULAR PURPOSE TO TWO (2) YEARS ON ALL COMPONENTS FROM THE DATE OF FIRST PURCHASE; AND DESA'S LIABILITY IS HEREBY LIMITED TO THE PURCHASE PRICE OF THE PRODUCT AND DESA SHALL NOT BE LIABLE FOR ANY OTHER DAMAGES WHATSOEVER INCLUDING INDIRECT, INCIDENTAL OR CONSEQUENTIAL DAMAGES.

Some states do not allow a limitation on how long an implied warranty lasts or an exclusion or limitation of incidental or consequential damages, so the above limitation on implied warranties, or exclusion or limitation on damages may not apply to you.

This warranty gives you specific legal rights, and you may also have other rights that vary from state to state.

For information about this warranty write:



2701 Industrial Drive  
P.O. Box 90004  
Bowling Green, KY 42102-9004  
www.desatech.com



111252 01

NOT A UPC

111252-01  
Rev. B  
09/03

For more information, visit [www.desatech.com](http://www.desatech.com)



## LESS

**NOTICE:** All accessories may not be available for all fireplace models.

Purchase these fireplace accessories from your local retailer. If they can not supply these accessories, call **DESA's** Sales Department at 1-866-672-6040 for information. You can also write to the address listed on the back page of this manual.

### BRICK LINER (Not Shown)

**BL36DA** - Textured Refractory Brick Liner Kit  
**BL36DSA** - Standard Refractory Brick Liner Kit  
**BL36DHA** - Textured Refractory Herringbone Brick Liner Kit  
**BL36DHSA** - Standard Refractory Herringbone Brick Liner Kit

This brick liner adds a touch of style to your direct-vent fireplace. Complete installation instructions included in this manual.

### FLEXIBLE GAS LINE CONNECTOR - GA5081 (Not Shown)

For all models.

### PROPANE/NATURAL GAS CONVERSION KIT (Not Shown) (Included with CHDV Models)

**PCDM-36VA** - Propane/L.P Gas Conversion Kit  
**NCDM-36VA** - Natural Gas Conversion Kit

### FACE/LOUVER PANEL KIT (Not Shown)

**FPD36** - Filligree Panel Kit - Black  
**FPD36B** - Filligree Panel Kit - Brushed Brass  
**FPD36P** - Filligree Panel Kit - Platinum  
**FPD36PB** - Filligree Panel Kit - Polished Brass

### LOUVER TRIM KIT (Rolled Louvers Only) (Not Shown)

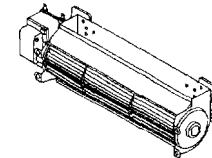
**LT36B** - Rolled Louver Trim Kit - Brushed Brass  
**LT36P** - Rolled Louver Trim Kit - Platinum  
**LT36PB** - Rolled Louver Trim Kit - Polished Brass

### DEFLECTION HOODS (Not Shown)

**HD36** - Hood - Black (2" Brow)

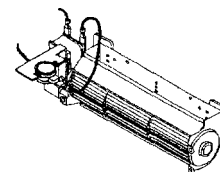
### PERIMETER TRIM KIT (Not Shown)

**PT36** - Perimeter Trim Kit - Black  
**PT36B** - Perimeter Trim Kit - Brushed Brass  
**PT36P** - Perimeter Trim Kit - Platinum  
**PT36PB** - Perimeter Trim Kit - Polished Brass



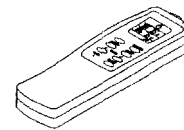
### MANUAL BLOWER KIT - BK

Manual variable control blower accessory provides better heat distribution. Complete installation and operation instructions included in this manual.



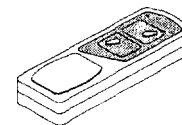
### THERMOSTATICALLY- CONTROLLED BLOWER KIT - BKT

Provides better heat distribution. Blower turns off and on automatically, as needed. Complete installation and operation instructions included in this manual.



### RECEIVER AND HAND-HELD THERMOSTAT REMOTE CONTROL KIT - (C)GHRCTB SERIES

Allows the fireplace to be operated in a manually or thermostatically-controlled mode. You can adjust your heat settings and turn the fireplace on or off without leaving the comfort of your easy chair.



### RECEIVER AND HAND-HELD ON/OFF REMOTE CONTROL KIT - (C)GHRCB SERIES

Allows the fireplace to be turned on and off conveniently.

### WALL MOUNTED THERMOSTAT CONTROL KIT - GWMTI (Not Shown)

Allows easy wall access for thermostatic operation of your fireplace.

### WALL MOUNTED ON/OFF SWITCH - GWMS2 (Not Shown)

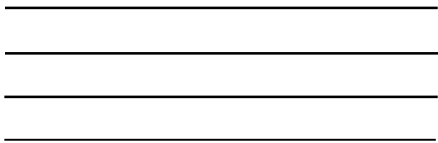
Allows burner system to be turned on and off with a wall switch.

For more information, visit [www.desatech.com](http://www.desatech.com)

**DESA**

TAPE

Postage  
Required



**DESA**<sup>™</sup>

2701 Industrial Drive  
P.O. **Box** 90004  
Bowling Green, KY 42102-9004

TAPE