

**City of Portland, Maine - Building or Use Permit Application**

389 Congress Street, 04101 Tel: (207) 874-8703, Fax: (207) 874-8716

Permit No: 09-0196	Issue Date:	CBL: 389 G003001
-----------------------	-------------	---------------------

Location of Construction: 186 CURTIS RD	Owner Name: GALLI ERNEST & JAMES M SK	Owner Address: 63 MORNING ST	Phone:
Business Name:	Contractor Name: Grover Contracting	Contractor Address: 51 Burnham Drive Naples	Phone 2075777282
Lessee/Buyer's Name	Phone:	Permit Type: HVAC	Zone: R2

Past Use: Single Family Home	Proposed Use: Single Family Home - install a Carrier Reznor & bradford white water heater in basement	Permit Fee: \$120.00	Cost of Work: \$9,400.00	CEO District: 5
Proposed Project Description: install a Carrier Reznor & bradford white water heater in basement		FIRE DEPT: <input type="checkbox"/> Approved <input type="checkbox"/> Denied	INSPECTION: Use Group: Type: 50 IRC 2003	
		Signature: <i>JM</i> 3/13/09		
		PEDESTRIAN ACTIVITIES DISTRICT (P.A.D.) Action: <input type="checkbox"/> Approved <input type="checkbox"/> Approved w/Conditions <input type="checkbox"/> Denied Signature: Date:		

Permit Taken By: Ldobson	Date Applied For: 03/12/2009	<b>Zoning Approval</b>
-----------------------------	---------------------------------	------------------------

- This permit application does not preclude the Applicant(s) from meeting applicable State and Federal Rules.
- Building permits do not include plumbing, septic or electrical work.
- Building permits are void if work is not started within six (6) months of the date of issuance. False information may invalidate a building permit and stop all work..

Special Zone or Reviews	Zoning Appeal	Historic Preservation
<input type="checkbox"/> Shoreland <input type="checkbox"/> Wetland <input type="checkbox"/> Flood Zone <i>NA</i> <input type="checkbox"/> Subdivision <input type="checkbox"/> Site Plan Maj <input type="checkbox"/> Minor <input type="checkbox"/> MM <input type="checkbox"/> Date: <i>JM</i>	<input type="checkbox"/> Variance <input type="checkbox"/> Miscellaneous <input type="checkbox"/> Conditional Use <input type="checkbox"/> Interpretation <input type="checkbox"/> Approved <input type="checkbox"/> Denied Date:	<input checked="" type="checkbox"/> Not in District or Landmark <input checked="" type="checkbox"/> Does Not Require Review <input type="checkbox"/> Requires Review <input type="checkbox"/> Approved <input type="checkbox"/> Approved w/Conditions <input type="checkbox"/> Denied Date: <i>JM</i>

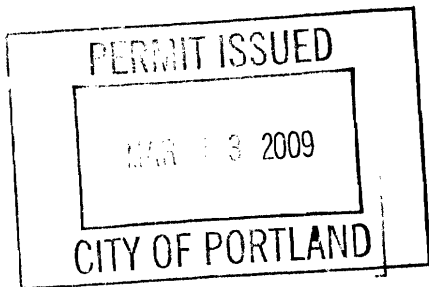

**CERTIFICATION**

I hereby certify that I am the owner of record of the named property, or that the proposed work is authorized by the owner of record and that I have been authorized by the owner to make this application as his authorized agent and I agree to conform to all applicable laws of this jurisdiction. In addition, if a permit for work described in the application is issued, I certify that the code official's authorized representative shall have the authority to enter all areas covered by such permit at any reasonable hour to enforce the provision of the code(s) applicable to such permit.

SIGNATURE OF APPLICANT	ADDRESS	DATE	PHONE
RESPONSIBLE PERSON IN CHARGE OF WORK, TITLE		DATE	PHONE



FILL IN AND SIGN WITH INK

# APPLICATION FOR PERMIT HEATING OR POWER EQUIPMENT

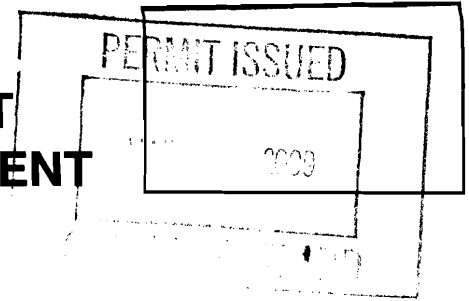

To the INSPECTOR OF BUILDINGS, PORTLAND, ME.

The undersigned hereby applies for a permit to install the following heating, cooking or power equipment in accordance with the Laws of Maine, the Building Code of the City of Portland, and the following specifications:

Location / CBL 186 CURTIS RD Use of Building RESIDENTIAL Date 3-12-09  
Name and address of owner of appliance ERVIE & LORI GALL

Installer's name and address GROVER CONTRACTING  
51 Burnham DR Naples Fla 34105 Telephone 207-577-7282

### Location of appliance:

- Basement
- Floor
- Attic
- Roof

### Type of Fuel:

- Gas
- Oil
- Solid

Appliance Name: CARRIER, REZNOR

U.L. Approved  Yes  No BRADFORD - WHITE

Will appliance be installed in accordance with the manufacture's installation instructions?  Yes  No

IF NO Explain: \_\_\_\_\_

### The Type of License of Installer:

- Master Plumber # \_\_\_\_\_
- Solid Fuel # \_\_\_\_\_
- Oil # \_\_\_\_\_
- Gas # PNT3882
- Other \_\_\_\_\_

### Type of Chimney:

- Masonry Lined  
Factory built PVC
- Metal  
Factory Built U.L. Listing # \_\_\_\_\_
- Direct Vent  
Type \_\_\_\_\_ UL# \_\_\_\_\_

### Type of Fuel Tank

- Oil
- Gas

Size of Tank 500 IN Ground

Number of Tanks 1

Distance from Tank to Center of Flame 25 FT feet.

Cost of Work: \$ 9,400

Permit Fee: \$ 120

### Approved

### Approved with Conditions

Fire: \_\_\_\_\_

Ele.: \_\_\_\_\_

Bldg.: \_\_\_\_\_

- See attached letter or requirement

Inspector's Signature \_\_\_\_\_

Date Approved \_\_\_\_\_

Signature of Installer [Signature]

**City of Portland, Maine - Building or Use Permit**

389 Congress Street, 04101 Tel: (207) 874-8703, Fax: (207) 874-8716

<b>Permit No:</b> 09-0196	<b>Date Applied For:</b> 03/12/2009	<b>CBL:</b> 389 G003001
------------------------------	--	----------------------------

<b>Location of Construction:</b> 186 CURTIS RD	<b>Owner Name:</b> GALLI ERNEST & JAMES M SKU	<b>Owner Address:</b> 63 MORNING ST	<b>Phone:</b>
<b>Business Name:</b>	<b>Contractor Name:</b> Grover Contracting	<b>Contractor Address:</b> 51 Burnham Drive Naples	<b>Phone</b> (207) 577-7282
<b>Lessee/Buyer's Name</b>	<b>Phone:</b>	<b>Permit Type:</b> HVAC	

<b>Proposed Use:</b> Single Family Home - install a Carrier Reznor & bradford white water heater in basement	<b>Proposed Project Description:</b> install a Carrier Reznor & bradford white water heater in basement
---	--

<b>Dept:</b> Zoning	<b>Status:</b> Not Applicable	<b>Reviewer:</b> Tom Markley	<b>Approval Date:</b> 03/13/2009
<b>Note:</b>			<b>Ok to Issue:</b> <input checked="" type="checkbox"/>
<b>Dept:</b> Building	<b>Status:</b> Approved with Conditions	<b>Reviewer:</b> Tom Markley	<b>Approval Date:</b> 03/13/2009
<b>Note:</b>			<b>Ok to Issue:</b> <input checked="" type="checkbox"/>
1) The installation must comply with the State of Maine Gas Regulations. 2) Application approval based upon information provided by applicant. Any deviation from approved plans requires separate review and approval prior to work.			

*Please mail to:  
Grover Contracting  
51 Burnham Drive  
Naples, ME 04055*

**INFINITY ICS, MODEL 58MVC  
DIRECT VENT 4-WAY MULTIPOISE  
MODULATING CONDENSING GAS FURNACE  
WITH IDEALCOMFORT™ IDEALHUMIDITY™**



Turn to the Experts™

## Owner's Manual

**NOTE TO INSTALLER:**

THIS MANUAL MUST BE LEFT WITH THE EQUIPMENT USER.

**USER:** Please read all instructions in the manual and retain all manuals for future reference.



As an ENERGY STAR® Partner, Carrier Heating & Cooling Systems has determined that this product meets the ENERGY STAR® guidelines for energy efficiency.

### **WARNING**

#### **FIRE OR EXPLOSION HAZARD**

Failure to follow safety warnings exactly could result in injury, death, or property damage.

Do not store or use gasoline or other flammable vapors and liquids in the vicinity of this or any other appliance.

#### **WHAT TO DO IF YOU SMELL GAS**

- Do not try to light any appliance.
- Do not touch any electrical switch; do not use any phone in your building.
- Leave the building immediately.
- Immediately call your gas supplier from a neighbor's phone. Follow the gas supplier's instructions.
- If you cannot reach your gas supplier, call the fire department.

Installation and service must be performed by a qualified installer, service agency or the gas supplier.

### **WARNING**

#### **CARBON MONOXIDE POISONING HAZARD**

Failure to follow this warning could result in personal injury and/or death.

Carbon Monoxide is invisible, odorless, and toxic! Carrier Heating and Cooling Systems recommends a carbon monoxide alarm in your home, even if you do not own a gas appliance. Locate the carbon monoxide alarm in the living area of your home and away from gas appliances and doorways to attached garages. Follow the alarm manufacturer's instruction included with the alarm.

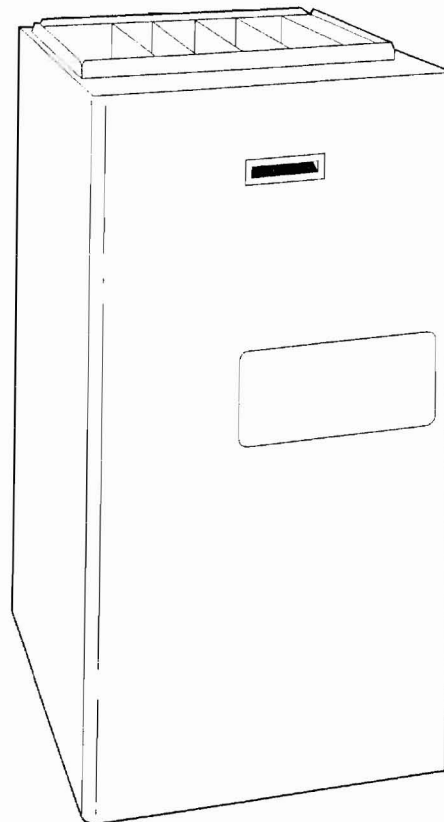

A05085

Do not use this furnace if any part has been under water. A flood-damaged furnace is extremely dangerous. Attempts to use the furnace can result in fire or explosion. A qualified service agency should be contacted to inspect the furnace and to replace all gas controls, control system parts, electrical parts that have been wet or the furnace if deemed necessary.

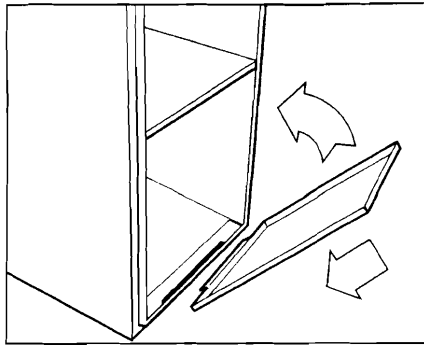

**Fig. 29 - Replace Blower Access Panel**

A93205

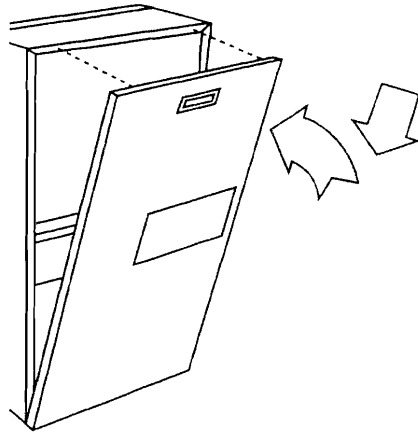

**Fig. 30 - Replace Furnace Door**

A05088

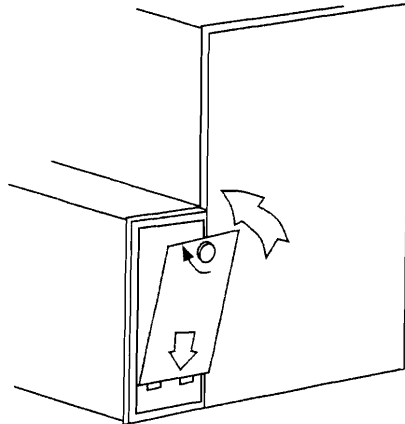

**Fig. 31 - Replace Side Filter Cabinet Door**

A06192

5. If washable filter, wash filter (if dirty) in sink, bathtub, or outside with a garden hose. Always use cold tap water. A mild liquid detergent may be used if necessary. Spray water through filter in the opposite direction of airflow. Allow filter to dry.
6. Reinstall clean air filter.
7. Reinstall filter retainer (for blower compartment locations only).
8. Replace blower access panel and main furnace door (Fig. 29 and 30.) or filter cabinet door. (Fig. 31 and 32.)
9. Turn on electrical supply to furnace.

If your furnace air filter needs to be replaced, be sure to use a factory-authorized filter of the same size that was originally

supplied. Use the filter tables and compare your furnace size with the proper filter size.

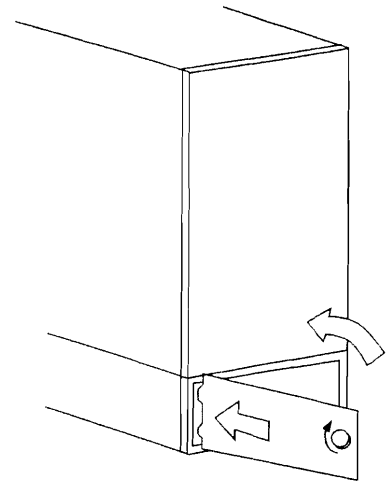

**Fig. 32 - Replace Bottom Filter Cabinet Door**

A06193

**FURNACE AIR FILTER TABLE**

AIR FILTER LOCATED IN BLOWER COMPARTMENT			
FURNACE CASING WIDTH (IN.)	FILTER SIZE (IN)		FILTER TYPE
	Side Return†*	Bottom Return*	
17-1/2	(1) 16 x 25 x 1	(1) 16 x 25 x 1	Cleanable
21	(1) 16 x 25 x 1	(1) 20 x 25 x 1	Cleanable
24-1/2	(1 or 2) 16 x 25 x 1	(1) 24 x 25 x 1	Cleanable
AIR FILTER LOCATED IN FILTER CABINET			
FILTER CABINET HEIGHT (IN)	FILTER SIZE (IN)	FILTER TYPE	
16	(1) 16 x 25 x 1*	Cleanable or Disposable	
20	(1) 20 x 25 x 1* or (1) 20 x 25 x 4-5/16	Cleanable or Disposable	
24	(1) 24 x 25 x 1* or (1) 24 x 25 x 4-5/16	Cleanable or Disposable	

\*Factory-provided with the furnace. Filters may be field modified by cutting filter material and support rods (3) in filters.

† Upflow only. Alternate sizes and additional filters may be ordered from your dealer.

**⚠ WARNING**

**PERSONAL INJURY HAZARD**

Failure to follow this warning could result in personal injury.

Use care when cutting support rods in filters to protect against flying pieces and sharp rod ends. Wear safety glasses, gloves, and appropriate protective clothing.

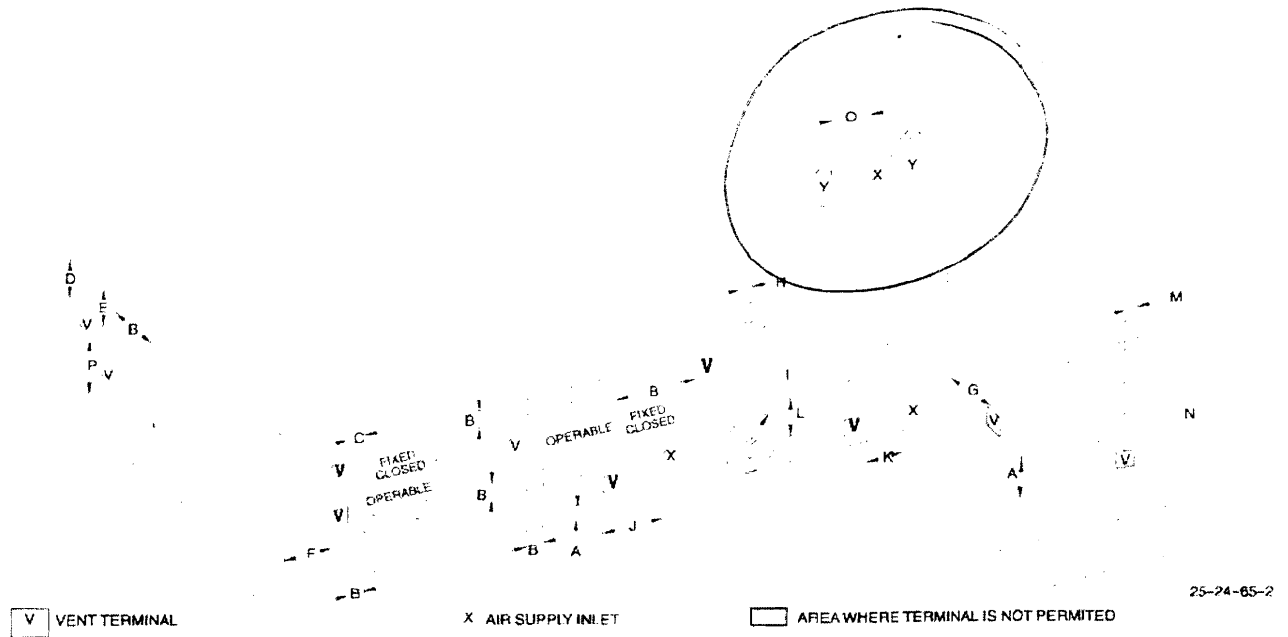

Item	Clearance Description	Canadian Installation (1)	U.S. Installation (2)
A	Clearance above grade, veranda, porch, deck, balcony, or anticipated snow level	12 inches (30 cm) #	12 inches (30 cm)
B	Clearance to a window or door that may be opened	12 inches (30 cm) for appliances > 10,000 Btuh (3 kW) and ≤ 100,000 Btuh (30 kW), 36 inches (91 cm) for appliances > 100,000 Btuh (30 kW)	8 inches (23 cm) for appliances > 10,000 Btuh (3kW) and ≤ 50,000 Btuh (15kW), 12 inches (30cm) for appliances > 50,000 Btuh (15kW)
C	Clearance to a permanently closed window	*	*
D	Vertical clearance to a ventilated soffit located above the terminal within a horizontal distance of 2 feet (61 cm) from the centerline of the terminal	*	*
E	Clearance to an unventilated soffit	*	*
F	Clearance to an outside corner	*	*
G	Clearance to an inside corner	*	*
H	Clearance to each side of the centerline extended above electrical meter or gas service regulator assembly	3 feet (91 cm) within 15 feet (4.5 m) above the meter/regulator assembly	3 feet (91 cm) within 15 feet (4.5 m) above the meter/regulator assembly
I	Clearance to service regulator vent outlet	3 feet (91 cm)	*
J	Clearance to non-mechanical air supply inlet to building or the combustion air inlet to any other appliance	12 inches (30 cm) for appliances > 10,000 Btuh (3 kW) and ≤ 100,000 Btuh (30kW), 36 inches (91cm) for appliances > 100,000 Btuh (30kW)	8 inches (23 cm) for appliances > 10,000 Btuh (3kW) and ≤ 50,000 Btuh (15kW), 12 inches (30cm) for appliances > 50,000 Btuh (15kW)
K	Clearance to a mechanical air supply inlet	6 feet (1.83 m)	3 feet (91 cm) above it within 10 feet (3m) horizontally
L	Clearance under a veranda, porch, deck, or balcony	12 inches (30 cm) +	*
M	Clearance to each side of the centerline extended above or below vent terminal of the furnace to a dryer or water heater vent, or other appliance's direct vent intake or exhaust.	12 inches (30 cm)	12 inches (30 cm)
N	Clearance to the vent terminal of a dryer vent, water heater vent, or other appliances direct vent intake or exhaust.	3 feet (91 cm)	3 feet (91 cm)
O	Clearance from a plumbing vent stack	3 feet (91 cm)	3 feet (91 cm)
P	Clearance above paved sidewalk or paved driveway located on public property	7 feet (2.13m)**	*

(1.) In accordance with the current CSA B149.1, Natural Gas and Propane Installation Code

(2.) In accordance with the current ANSI Z223.1/NFPA 54, National Fuel Gas Code

# 18" (46 cm) above roof surface

+ Permitted only if veranda, porch, deck, or balcony is fully open on a minimum of two sides beneath the floor.

\* For clearances not specified in ANSI Z223.1/NFPA 54 or CSA B149.1, clearances shall be in accordance with local installation codes and the requirements of the gas supplier and the manufacturer's installation instructions

\*\* A vent shall not terminate above a sidewalk or paved driveway that is located between two single family dwellings and serves both dwellings

Notes:

1. The vent for this appliance shall not terminate
  - a. Over public walkways; or
  - b. Near soffit vents or crawl space vents or other areas where condensate or vapor could create a nuisance or hazard or property damage; or
  - c. Where condensate vapor could cause damage or could be detrimental to the operation of regulators, relief valves, or other equipment.
2. When locating vent terminations, consideration must be given to prevailing winds, location, and other conditions which may cause recirculation of the combustion products of adjacent vents. Recirculation can cause poor combustion, inlet condensate problems, and accelerated corrosion of the heat exchangers.
3. Avoid venting under a deck or large overhang. Recirculation could occur and cause performance or system problems.

Fig. 34 - Direct Vent Termination Clearance

# Power Vented, Low Static Axial Fan Unit Heaters for Residential and Commercial/Industrial Use Sizes 30-125

approved for utility applications  
such as residential garages  
under CSA International Requirement  
10.96 - U.S. and CR96-0005 - Canada

REZTOR  
Model UDAP

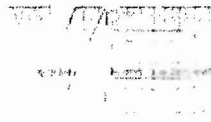
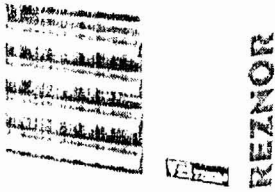

CSA 2.6b



ANSI Z83.8b



## DESCRIPTION

Reznor® V3 Series Model UDAP gas-fired unit heaters are available in 14 sizes ranging from 30,000 to 400,000 BTUH gas input. Sizes 30-125 are approved for residential application. All sizes are approved for commercial/industrial installations. Model UDAP heaters are designed for 82-83% thermal efficiency and are approved for installation in the United States and Canada by the Canadian Standards Association (CSA).

Reznor V3 Series unit heaters have a refreshing new appearance with a glossy white cabinet finish and less visible hardware. Each size cabinet is easily suspended from either 2 or 4 suspension points. Or, an optional hanger kit for Sizes 30-125 allows for ceiling mounting. The low voltage terminal strip on the outside of the cabinet makes connecting control wiring easy with no panels to remove. The addition of a "G" terminal to the strip, along with the new design of the circuit board, allows for fan only operation (without adding relays). All units have a factory installed gas line nipple to the exterior of the cabinet for easy gas service connection.

The preeminent new internal feature is the TcORE2® heat exchanger and single burner combustion system. Other standard features include a single-stage gas valve, multi-try direct spark ignition with 100% lockout, pressure switch to verify vent flow, resiliently isolated venter motor, venter wheel with improved housing, resiliently isolated axial fan and motor assembly, and a high temperature limit control. Sizes 30-125 also include a flame rollout safety switch. Operation is controlled through an integrated circuit board. The circuit board monitors heater operation and has LED diagnostic indicator lights to identify abnormalities in control functions.

The V3 Series unit heaters are designed to provide all the features you expect in a Reznor heater plus improved efficiency, easier installation, and a new look ~ *both inside and out*. Look for the unique white unit with no visible front and bottom hardware, deep red louvers, black side handle, and angled corner to know you have a genuine Reznor unit by Thomas & Betts.

## STANDARD FEATURES

- Sizes 30-125 certified for residential heating application
- Sizes 30-400 certified for commercial/industrial heating application
- 82-83% Thermal efficient ~ *TOP in its class!*
- 50-60°F Rise range
- TcORE2® titanium stabilized aluminized steel heat exchanger
- Patented\*\* TcORE2® single burner combustion system including a one-piece burner assembly
- 115/1/60 Supply voltage
- 115 Volt open fan motor with internal overload protection
- Transformer for 24-volt controls
- Integrated circuit board with diagnostic indicator lights
- Multi-try direct spark ignition with 100% lockout
- Fan relay (included on the circuit board)
- Single-stage natural gas valve (field adjustable for operation to 9,000 ft. elevation)
- Vibration/noise isolated fan and venter motors ~ *designed for low noise operation*
- 2-pt and 4-pt Suspension ~ *standard on all sizes*
- External terminal strip for 24-volt wiring
- External gas connection
- Full fan guard ~ *engineered for safety*
- Improved cabinet design with less visible hardware and a *NEW* Reznor appearance

## OPTIONAL FEATURES - FACTORY INSTALLED

- Single-stage, propane gas valve (field adjustable for operation to 9,000 ft. elevation)
- Two-stage natural gas or propane gas valve - Sizes 60-400
- 409 or 316 Stainless steel heat exchangers
- 208 or 230 Single phase voltage
- Totally enclosed fan motor (Sizes 30-250, 115V only)
- Common venting with other gravity vented Category I appliance(s) (Sizes 30-100)

**OPTIONAL FEATURES -  
FIELD INSTALLED**

- Vent cap
- Thermostat
- Thermostat guard with locking cover
- Vertical louvers ~ *new design*
- Downturn nozzle kits ~ *new design*
- Gas conversion kits (natural and propane)
- Master/Slave controls for zoning up to six units
- Ceiling suspension kit - Sizes 30-125
- Hanger kits for 1" pipe
- Stepdown transformer (for 230/3 and 460/3 supply voltage)
- Manual shutoff valves

**TECHNICAL DATA**

Model UDAP

Size		30	45	60	75	100	125	150	175	200	225	250	300	350	400
Input Heating Capacity	BTUH	30,000	45,000	60,000	75,000	105,000	120,000	150,000	175,000	200,000	225,000	250,000	300,000	350,000	400,000
	kWh	8.6	13.2	17.6	22.0	30.8	35.2	43.9	51.2	58.6	65.9	73.2	87.8	102.5	117.1
Thermal Efficiency (%)		82	83	83	83	83	83	83	83	83	83	83	83	83	83
Output Heating Capacity <sup>A</sup>	BTUH	24,600	37,350	49,800	62,250	87,150	99,600	124,500	145,250	166,000	186,750	207,500	249,000	290,500	332,000
	kWh	7.2	11.0	14.6	18.3	25.6	29.2	36.4	42.5	48.6	54.7	60.8	72.9	85.1	97.2
Gas Connection (inches) <sup>B</sup>	Natural	1/2	1/2	1/2	1/2	1/2	1/2	1/2	1/2	1/2	3/4	3/4	3/4	3/4	3/4
	Propane	1/2	1/2	1/2	1/2	1/2	1/2	1/2	1/2	1/2	3/4	3/4	3/4	3/4	3/4
Vent Connection Size <sup>C</sup> (inches diameter)		4	4	4	4	4	4	5	5	5	5	5	6	6	6
Control Amps (24 volt)		1.0	1.0	1.0	1.0	1.0	1.0	1.0	1.0	1.0	1.0	1.0	1.0	1.0	1.0
Full Load Amps (115 volt)		1.9	2.4	2.4	3.3	3.9	5.1	3.8	3.8	4.6	7.5	7.5	11.0	11.0	11.0
Maximum Over Current Protection (115V) <sup>D</sup>		15	15	15	15	15	15	15	15	15	15	15	20	20	20
Normal Power Consumption (watts)		109	155	155	217	276	354	392	392	491	747	747	1086	1086	1086
Discharge Air Temperature Rise (°F)		50	55	60	60	60	60	60	60	60	60	60	60	60	60
Air Volume	CFM	456	629	769	961	1345	1537	1921	2242	2562	2882	3202	3843	4483	5123
	M <sup>3</sup> /minute	12.9	17.8	21.8	27.5	36.7	45.9	54.4	63.5	72.5	81.6	90.7	108.8	126.9	145.1
Discharge Air Opening Area	ft <sup>2</sup>	0.96	0.96	1.25	1.25	2.01	2.01	2.56	2.56	2.56	3.51	3.51	4.79	4.79	4.79
	M <sup>2</sup>	0.09	0.09	0.12	0.12	0.19	0.19	0.24	0.24	0.24	0.33	0.33	0.45	0.45	0.45
Output Velocity	FPM	475	656	616	770	668	763	752	877	1003	820	911	802	936	1069
	M/minute	145	200	188	238	196	245	229	267	306	250	278	244	285	326
Fan Motor HP <sup>E</sup>	Open	0.02	0.03	0.03	0.06	1/30	1/20	1/6	1/6	1/6	1/4	1/4	1/2	1/2	1/2
	Enclosed	0.06	0.06	0.06	0.06	1/4	1/4	1/4	1/4	1/4	1/4	1/4	1/2	1/2	1/2
Fan Motor RPM		1550	1550	1550	1550	1050	1050	1050	1050	1050	1050	1050	1050	1050	1050
Fan Diameter (inches)		10	10	12	12	16	16	18	18	18	20	20	24	24	24
Sound Level	dB(A) @ 15 ft	40	40	40	49	54	55	51	52	53	56	56	59	61	62
Approximate Net Weight	lbs	54	59	67	72	96	101	172	187	187	203	215	269	294	306
	kg	24	27	30	33	44	46	78	85	85	92	98	122	133	139
Approximate Ship Weight	lbs	61	66	74	79	118	123	204	219	219	245	257	321	346	358
	kg	27	30	33	36	54	56	93	100	100	111	117	146	157	163

<sup>A</sup> CSA rating for altitudes to 2000 ft.

<sup>B</sup> Size shown is for gas connection to a single stage gas valve, not supply line size.

<sup>C</sup> Smaller or larger vent pipe diameters may be allowed; refer to the Venting Installation Manual, Form I-V-PV. If vent diameter is different from vent connection, reducer/enlargers will be field-required.

<sup>D</sup> MODP = 2.25 x (largest motor FLA) + smallest motor FLA. Answer is rounded to the nearest commercially available circuit breaker.

<sup>E</sup> All other information in this table is based on a heater equipped with a standard 115 volt open fan motor.



**DESCRIPTION**

Model UDAP

±1/16" (2mm)

Size	A	B	C	D	E	F	G	H	J	K	M	N	P	Q	R
30, 45	12 1/8	25 5/8	10	13 13/16	26	21 9/16	5 3/16	6 1/2	2 11/16	3 7/8	17 3/8	11/16	4 5/16	13	9 9/16
60	15 1/8	25 5/8	13	13 13/16	27	21 9/16	7 7/8	6 1/2	5 1/2	3 7/8	17 3/8	11/16	4 5/16	13	10 1/2
75	15 1/8	25 5/8	13	13 13/16	27 5/8	21 9/16	7 7/8	6 1/2	5 1/2	3 7/8	17 3/8	11/16	4 5/16	13	10 1/2
100	23 1/8	25 5/8	21	13 13/16	28 5/8	21 9/16	14 1/2	6 1/2	8 3/4	3 7/8	17 3/8	11/16	4 5/16	13	10 1/2
125	23 1/8	25 5/8	21	13 13/16	29 3/8	21 9/16	14 1/2	6 1/2	8 3/4	3 7/8	17 3/8	11/16	4 5/16	13	10 1/2
150 175, 200	20 1/8	38 3/16	16	23	42	35 3/8	8 1/2	8 1/4	5 7/16	6 1/2	25 11/16	1 3/8	8 3/16	22 3/16	16 3/8
225, 250	26 1/8	38 3/16	22	23	42	35 3/8	13 1/16	8 13/16	9	6 1/2	25 11/16	1 3/8	8 3/16	22 3/16	15 5/8
300 350, 400	34 1/8	41	30	23	42	35 3/8	17 1/16	9	11 13/16	7 5/16	27 11/16	1 3/8	8 3/16	22 3/16	16 3/16

Size	A	B	C	D	E	F	G	H	J	K	M	N	P	Q	R
30, 45	(308)	(651)	(254)	(351)	(660)	(548)	(132)	(165)	(68)	(98)	(441)	(17)	(110)	(330)	(243)
60	(384)	(651)	(330)	(351)	(686)	(548)	(200)	(165)	(140)	(98)	(441)	(17)	(110)	(330)	(267)
75	(384)	(651)	(330)	(351)	(702)	(548)	(200)	(165)	(140)	(98)	(441)	(17)	(110)	(330)	(267)
100	(587)	(651)	(533)	(351)	(727)	(548)	(368)	(165)	(222)	(98)	(441)	(17)	(110)	(330)	(267)
125	(587)	(651)	(533)	(351)	(746)	(548)	(368)	(165)	(222)	(98)	(441)	(17)	(110)	(330)	(267)
150 175, 200	(511)	(970)	(406)	(584)	(1,067)	(899)	(216)	(210)	(138)	(165)	(652)	(35)	(208)	(564)	(416)
225, 250	(664)	(970)	(559)	(584)	(1,067)	(899)	(332)	(224)	(229)	(165)	(652)	(35)	(208)	(564)	(397)
300, 350, 400	(867)	(1,041)	(762)	(584)	(1,067)	(899)	(433)	(229)	(300)	(186)	(703)	(35)	(208)	(564)	(411)

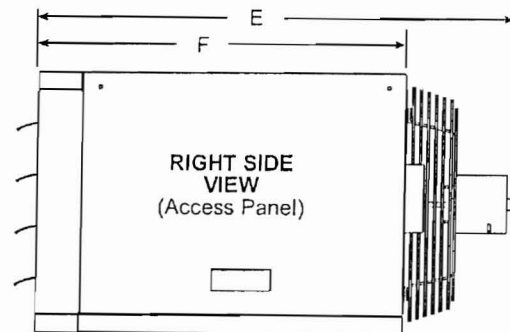
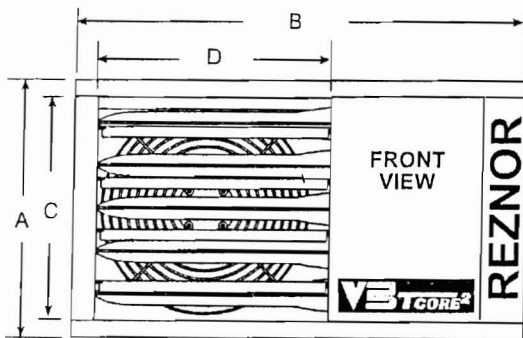
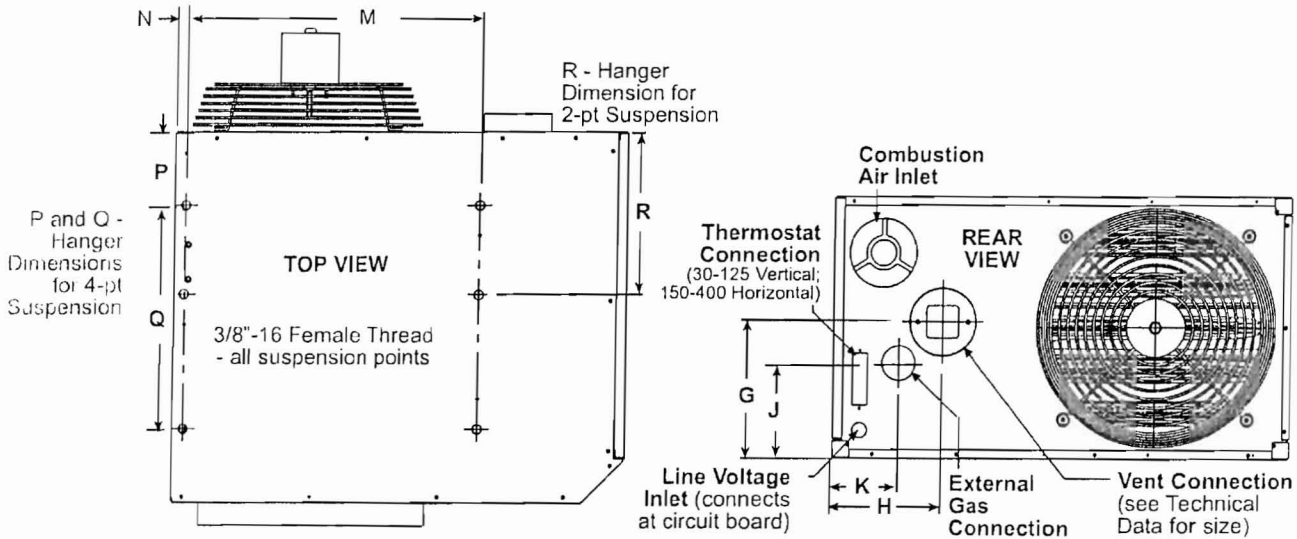

**CLEARANCES FROM COMBUSTIBLES**

Size	Top		Flue Connector		Access Panel		Non-Access Side		Bottom*		Rear	
	inches	mm	inches	mm	inches	mm	inches	mm	inches	mm	inches	mm
30-125	1	25	6	152	18	457	1	25	1	25	18	457
150-400	4	102	6	152	18	457	2	51	1	25	18	457

\*Suspend the heater so that the bottom is a minimum of 5' (1.5M) above the floor.

# TTW<sup>2</sup>

## Residential Power Vent Energy Saver Gas Water Heater

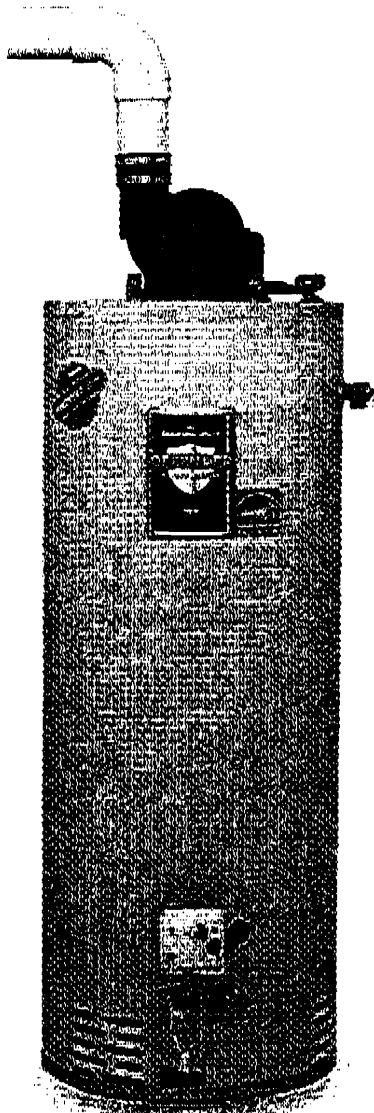

Photo is of  
M-2-TW-50T6FBN

The TTW<sup>2</sup> FVIR Defender Safety System<sup>®</sup> Models Feature (50 and 65 gallon models, only):

- **ENERGY STAR<sup>®</sup> Qualified**—These models qualify for the January 1st, 2009 minimum ENERGY STAR<sup>®</sup> EF requirement, as well as most utility rebate programs.
- **Advanced ScreenLok<sup>®</sup> Technology Flame Arrestor Design**—Flame arrestor is designed to prevent ignition of flammable vapor outside of the water heater.
- **Flammable Vapor Sensor**—Electronic sensor prevents burner operation if flammable vapors are detected. The sensor will also prevent operation if there is ongoing flammable vapor burn inside the combustion chamber.
- **Maintenance Free**—No regular cleaning of air inlet openings or flame arrestor is required under normal conditions.
- **Sight Window**—Offers a view into the combustion chamber to observe the operation of the pilot and burner.
- **Pedestal Base**—Rugged and durable base allows easy transport and positioning, and provides corrosion resistant contact with floor.

All TTW<sup>2</sup> Models Feature:

- **Powerful Blower Motor**—Our design has higher torque for greater resistance to outside winds and the power to eliminate problems with difficult venting situations. This significantly quieter motor runs cooler for a considerably longer operational life.
- **Factory Installed HydroJet<sup>®</sup> 2" Total Performance System**—Cold water inlet sediment reducing device helps prevent sediment build up in tank. Increases first hour delivery of hot water while minimizing temperature build up at top of tank.
- **Vitraglas<sup>®</sup> Lining**—Bradford White water heater tanks are protected from the corrosive effects of hot water by a ceramic porcelain-like coating. The exclusive high silica ceramic lining provides a tough interior surface for our water heater tank.
- **Spark to Pilot Ignition System**—Eliminates the constant burning pilot used on other water heaters. This device results in savings of pilot gas during standby periods. (110 VAC required to heater).
- **Electronic Gas Control Valve**—The integrated, immersion gas control valve offers more precise temperature control for higher first hour delivery and also allows water temperature adjustment without removing the cover. The control is equipped with an LED to display heater status and aid in diagnostics.
- **Horizontal and Vertical Venting**—With 3" or 4" PVC, ABS or CPVC (Maximum equivalent vent length on reverse side).
- **2" Non-CFC Foam Insulation**—Covers the sides and top of tank to save energy by retarding loss of heat. Also increases jacket rigidity.
- **Water Connections**—3/4" NPT factory installed true dielectric fittings. Extends water heater life and eases installation.
- **Factory Installed Heat Traps**—Design incorporates a flexible disk that reduces heat loss in piping and eliminates the potential for noise generation.
- **Protective Magnesium Anode Rod**—Provides added protection against corrosion for long trouble-free service.
- **Side Connections**—3/4" NPT female side tapings allow easy connections for space heating applications.
- **T&P Relief Valve**—Included.
- **Brass Drain Valve**.
- **Design Certified by CSA International (formerly AGA and CGA).**



**6 or 10-Year Limited Tank Warranties / 6-Year Limited Warranty on Component Parts.**

For more information on warranty, please visit [www.bradfordwhite.com](http://www.bradfordwhite.com)

For products installed in USA, Canada and Puerto Rico. Some states do not allow limitations on warranties. See complete copy of the warranty included with the heater.

MANUFACTURED UNDER ONE OR MORE OF THE FOLLOWING U.S. PATENTS: 5,954,492; 5,781,378; 5,943,984; 5,081,696; 5,988,117; 6,142,216; 5,199,385; 5,574,822; 5,372,185; 5,485,879; 5,277,171; (B1)5,341,770; 5,660,165; 5,596,952; 5,682,868; 4,904,428; 5,023,031; 5,000,893; 4,869,448; 4,829,883; 4,808,358; 5,115,767; 5,092,519; 5,052,346; 4,416,222; 4,628,184; 4,861,968; 4,672,919; Re. 34,534; 7,270,087 B2. OTHER U.S. AND FOREIGN PATENT APPLICATIONS PENDING. CURRENT CANADIAN PATENTS: 1,272,914; 1,280,043; 1,289,832; 2,045,862; 2,112,515; 2,108,186; 2,107,012; 2,092,105; 2,409,271 Defender Safety System<sup>®</sup>, ScreenLok<sup>®</sup>, TTW<sup>2</sup>, Vitraglas<sup>®</sup> and HydroJet<sup>®</sup> are registered trademarks of Bradford White<sup>®</sup> Corporation.

253-B-0109-A

# Residential Power Vent Gas Water Heater



## TTW® 2 Energy Saver Models

NATURAL GAS AND LIQUID PROPANE GAS

Meet or exceed ASHRAE 90.1b (current standard) C.E.C. Listed  
80% Recovery Efficiency

Model Number	Capacity		Recovery 90°F Rise*				A Floor to Vent Conn. In.	B Jacket Dia. In.	C Vent Size In.	D Floor to T&P Conn. In.	E Floor to Gas Conn. In.	F Floor to Space Heating Return In.	G Floor to Space Heating Outlet In.	H Floor to Heater Top In.	J Floor to Water Conn. In.	K Depth In.	Approx. Shipping Weight lbs.		
	U.S. Gal.	Imp. Gal.	Nat. BTU/Hr. Input	LP BTU/Hr. Input	Nat. U.S. GPH	Nat. Imp. U.S. GPH												LP U.S. GPH	LP Imp. GPH
M-2-TW-50T6FBN	48	40	57,000	60,000	72	60	65	54	65 1/2	22	3	50%	11%	13%	50%	58%	57%	26 1/2	188
M-2-TW-65T6FBN	65	54	70,000	63,000	75	63	68	56	69	24	3	53%	11%	13%	53%	59%	60%	28 1/2	222
M-2-TW-75T6BN	75	62	76,000	75,500	82	68	81	67	69 1/2	26	3	53%	15	17%	63	60%	61 1/2	31	277

Model Number	Capacity		Recovery 50°C Rise*				A Floor to Vent Conn. mm.	B Jacket Dia. mm.	C Vent Size mm.	D Floor to T&P Conn. mm.	E Floor to Gas Conn. mm.	F Floor to Space Heating Return mm.	G Floor to Space Heating Outlet mm.	H Floor to Heater Top mm.	J Floor to Water Conn. mm.	K Depth mm.	Approx. Shipping Weight kg.
	Liters	kW Input	Nat. kW Input	LP kW Input	Nat. Liters/Hour	LP Liters/Hour											
M-2-TW-50T6FBN	182	19.6	17.6	273	245	1673	500	76	1273	298	343	1273	1432	1467	673	86	
M-2-TW-65T6FBN	240	20.5	18.5	285	257	1753	610	76	1360	298	343	1360	1511	1543	730	101	
M-2-TW-75T6BN	284	22.9	22.1	310	306	1772	650	76	1345	381	451	1345	1530	1562	787	126	

Propane models feature a Titanium Stainless Steel propane burner. For Propane (LP) models change suffix "BN" to "SX".

M-2-TW-75 features a Cast Iron burner. For Propane (LP) model change suffix "BN" to "CX".

For 10 year models, change suffix from "6" to "10".

\*Based on manufacturer's rated recovery efficiency.

110 V.A.C. Required for Power Venting / 110 V.A.C. 60HZ 3.1 Amperes.

M-2-TW-75T does not qualify for ENERGY STAR®.

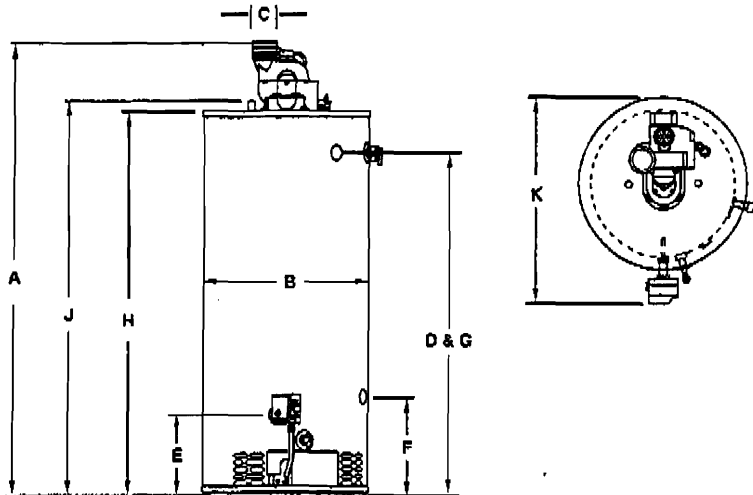

Note: (M-2-TW75 will not have a pedestal base).

	3" Vent Pipe	4" Vent Pipe
M-2-TW50		
M-2-TW65		
M-2-TW75		
Max. Equivalent Length	180 ft	140 ft
Min. Equivalent Length	7 ft	15 ft
Number of 90° Elbows	2	2
	50 ft	170 ft

Subtract 5ft. for each additional 90° elbow  
† For high altitude installations, consult the installation instructions.

\*\*M-2-TW75 Max. 3" vent length is 50ft.

### Meets NAECA Requirements

#### General

All gas water heaters are certified at 300 PSI (2068 kPa) test pressure and 150 PSI (1034 kPa) working pressure.

All water connections are 3/4" NPT (19mm) on 1 1/2" (279mm) centers, all gas connections are 1/2" (13mm).

All models design certified by CSA International (formerly AGA/CGA), ANSI Z-21.10.1 and/or 10.3 and peak performance rated.

*Dimensions and specifications subject to change without notice in accordance with our policy of continuous product improvement.*

#### Suitable for Water (Potable) Heating and Space Heating

Toxic chemicals, such as those used for boiler treatment, shall NEVER be introduced into this system. This unit may NEVER be connected to any existing heating system or component(s) previously used with a non-potable water heating appliance.



For U.S. and Canada field service, contact your professional installer or local Bradford White sales representative.

Sales 800-523-2931 • Fax 215-641-1670 / Technical Support 800-334-3393 • Fax 269-795-1089 • Warranty 800-531-2111 • Fax 269-795-1089

International: Telephone 215-641-9400 • Telefax 215-641-9750 / www.bradfordwhite.com

BRADFORD WHITE-CANADA INC. Sales / Technical Support 866-690-0961 / 905-238-0100 • Fax 905-238-0105 / www.bradfordwhite.com

## Built to be the Best™

©2009, Bradford White Corporation. All rights reserved.