

56 LEDGEWOOD DR.  
FALMOUTH, MAINE 04105  
CEL. (207) 632-5320  
MIKE@CDDHOME.COM

PROJECT NAME  
**SCOTT RES.**

PROJECT LOCATION  
LOT 41  
PAMELA RD  
PORTLAND, MAINE  
BUILT BY

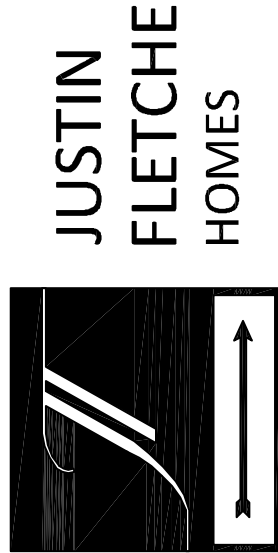

SHEET NAME  
**DETAILS**

© ALL RIGHTS RESERVED  
ALL IDEAS, DESIGNS AND PLANS INDICATED OR REPRESENTED BY THESE DRAWINGS ARE THE PROPERTY OF CURRAN DRAFTING AND DESIGN, INC. AND WERE CREATED AND DEVELOPED FOR USE ON OR IN CONNECTION WITH THE SPECIFIED PROJECT NAME & SHALL BE REPRODUCED OR COPIED BY ANYONE FOR ANY PURPOSE WITHOUT THE WRITTEN PERMISSION OF CURRAN DRAFTING AND DESIGN, INC. THESE PLANS ARE INTENDED FOR A ONE-COPY USE ONLY. ANY REPRODUCTION OF THESE PLANS WITHOUT THE WRITTEN PERMISSION OF CURRAN DRAFTING AND DESIGN, INC. IS PROHIBITED. THIS TITLE BLOCK IS NOT "RED" IN COLOR.  
DRAWN BY: M.P.C.  
CHECKED BY: M.P.C.  
SCALE: AS-NOTED  
DATE: 08/03/17  
FILE NUMBER 17-0034  
REVISIONS:  
▽

**A-7**

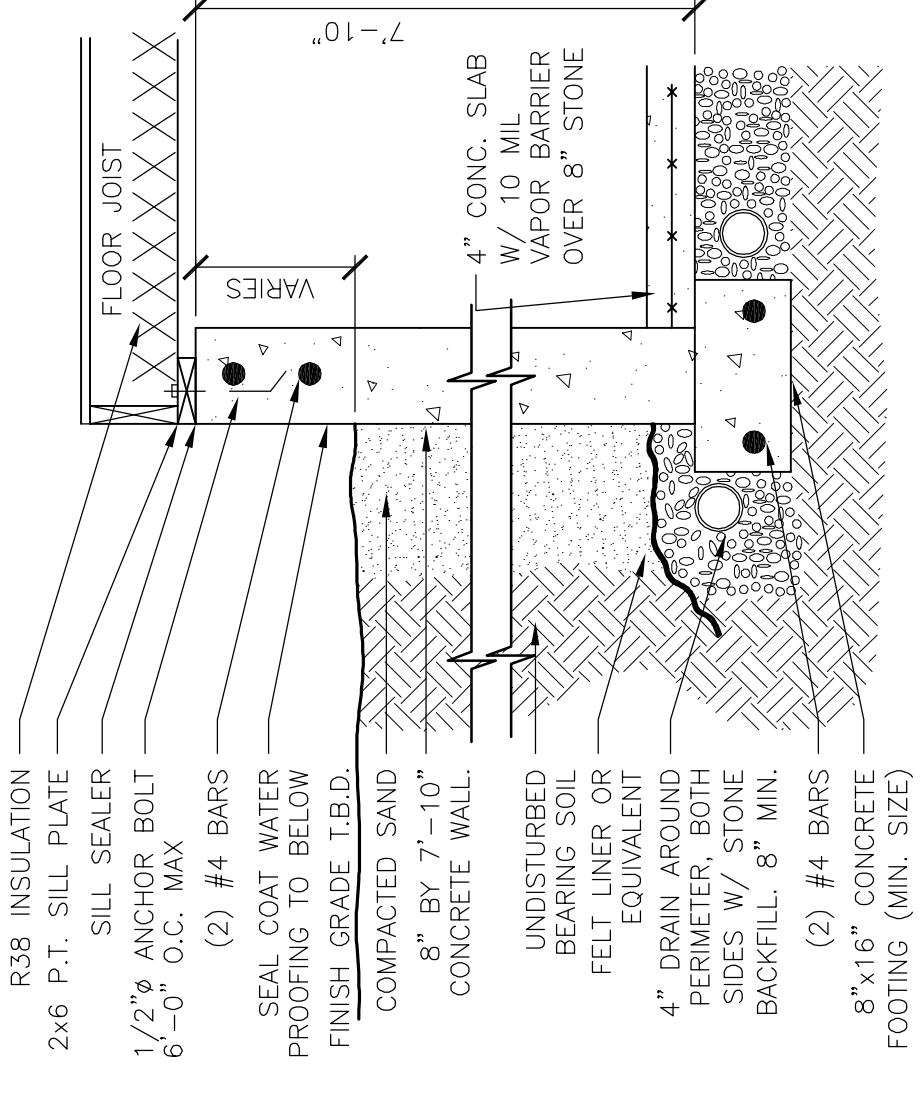

**1 SLAB & FOUND. WALL DETAIL**  
A7 3/4" = 1'-0"

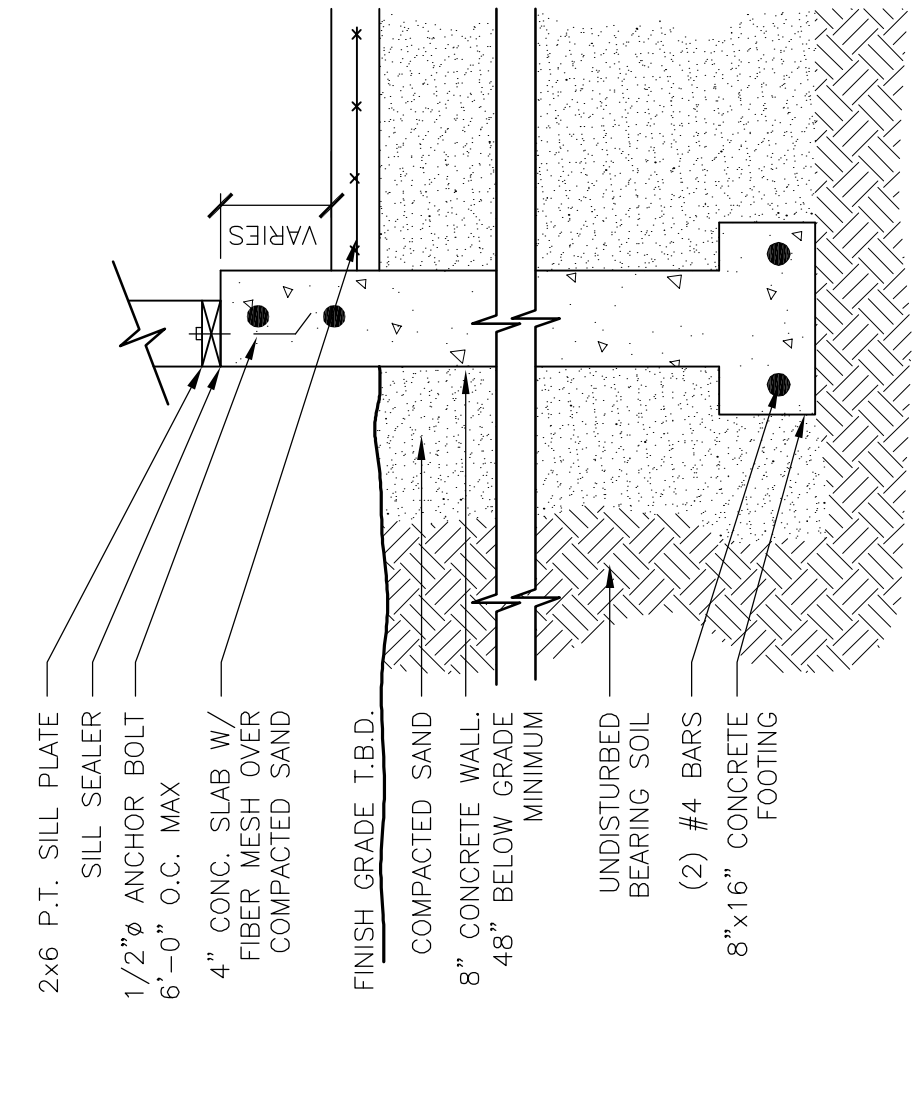

**2 SLAB & FROST WALL @ GARAGE**  
A7 3/4" = 1'-0"

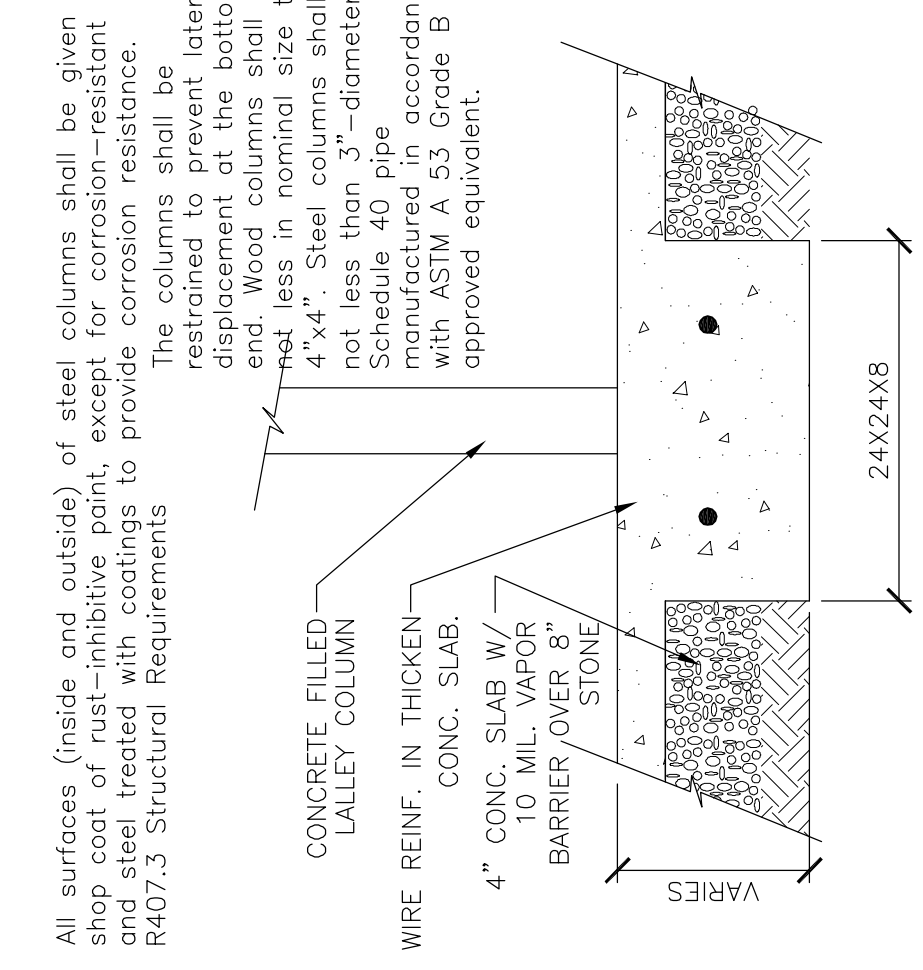

**3 THICKEN SLAB DETAIL**  
A7 3/4" = 1'-0"

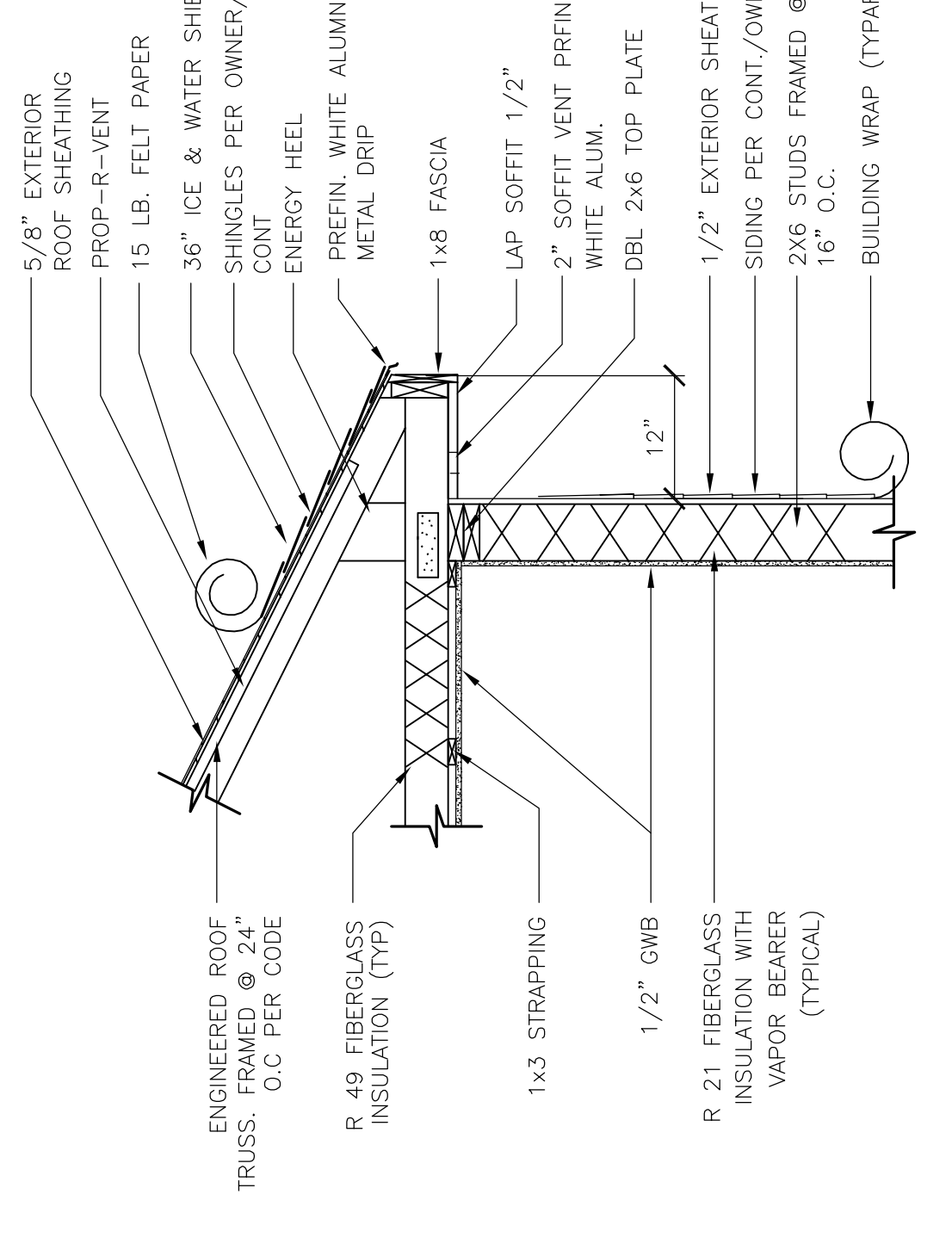

**4 WALL, ROOF & SOFFIT DETAIL**  
A7 3/4" = 1'-0"

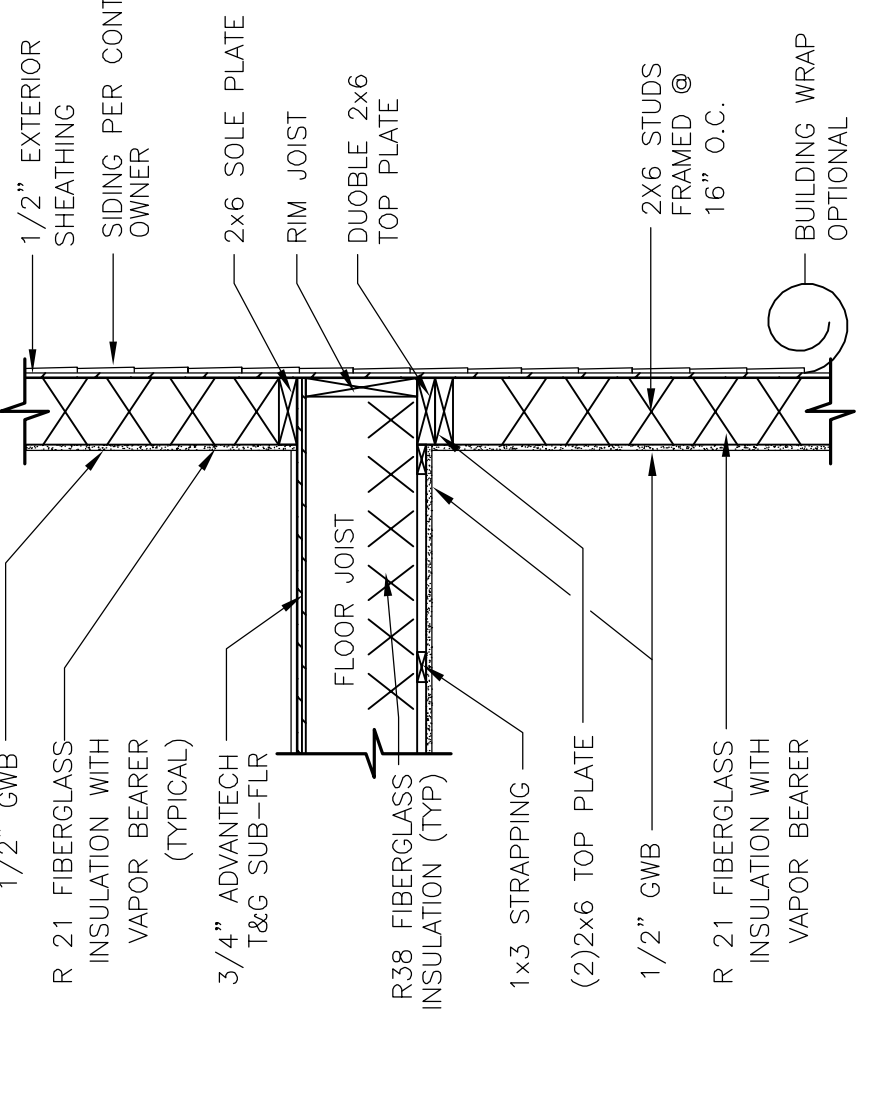

**5 EXTERIOR WALL DETAIL**  
A7 3/4" = 1'-0"

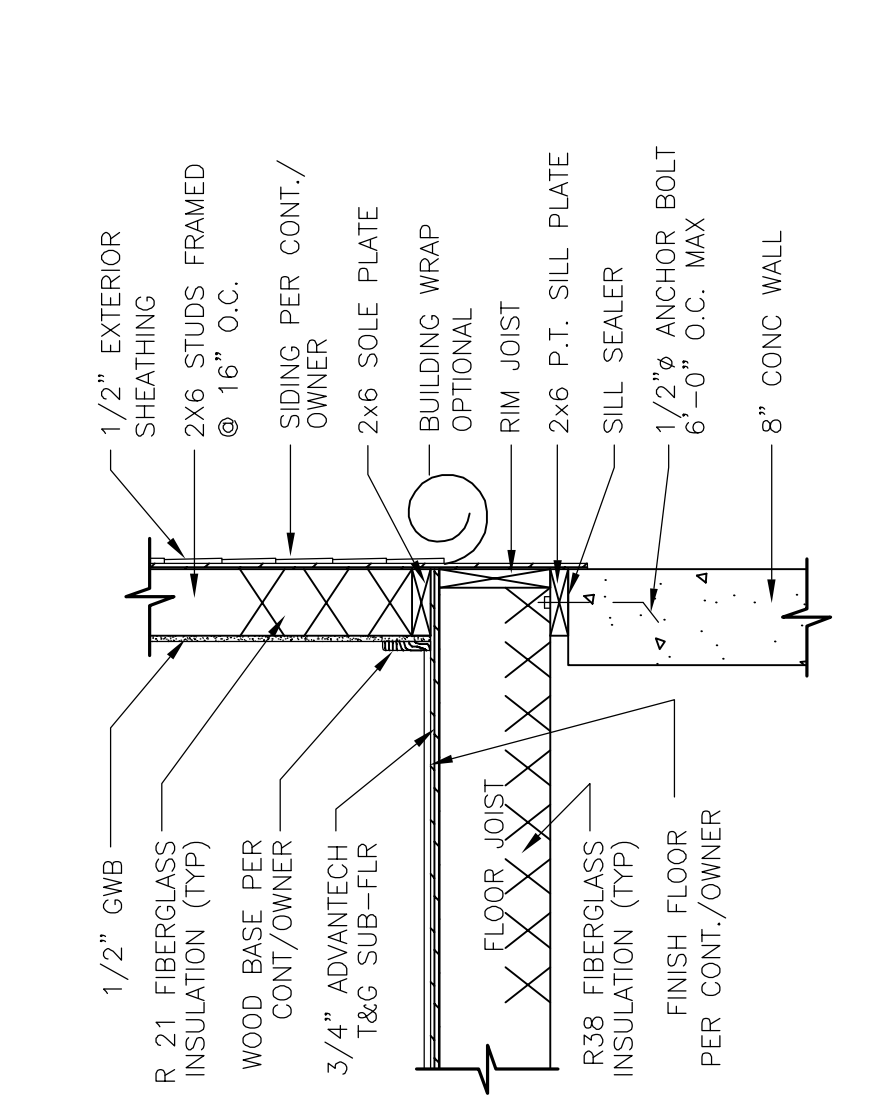

**6 WALL BASE DETAIL**  
A7 3/4" = 1'-0"

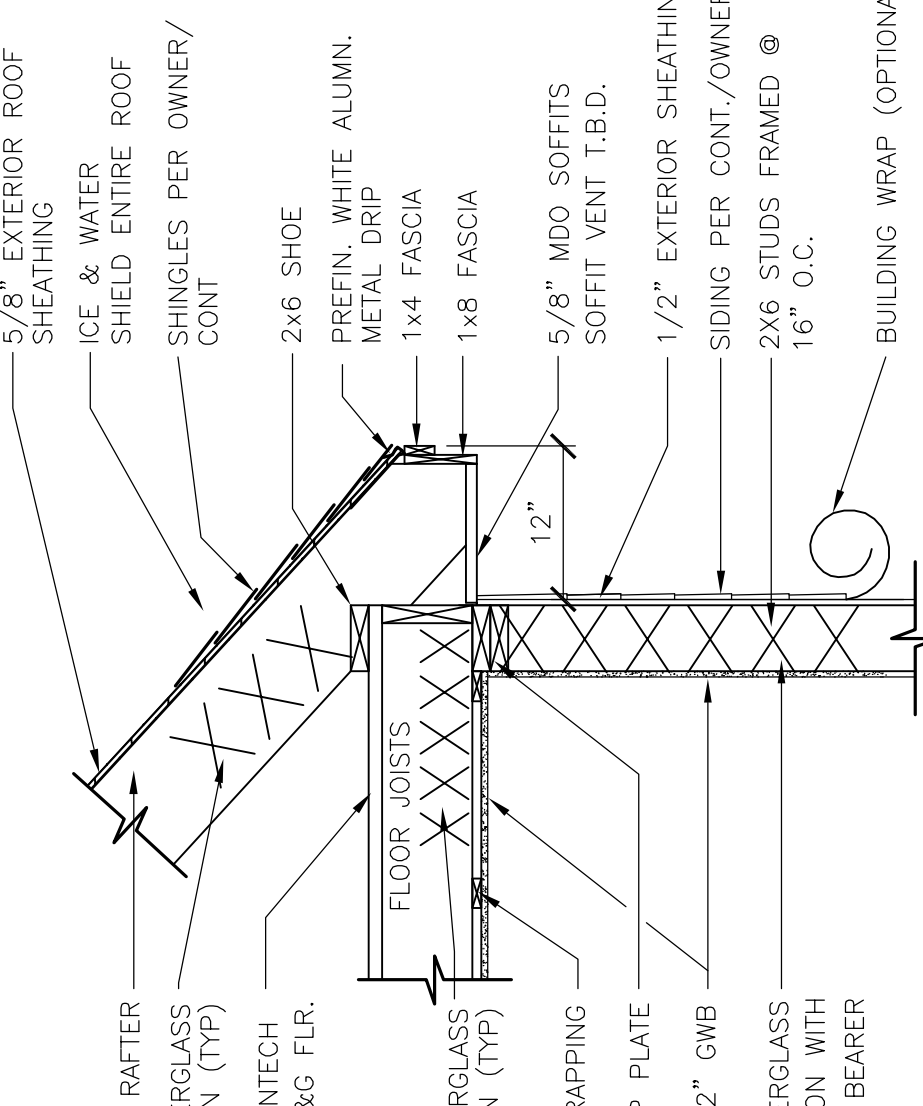

**7 SOFFIT DETAIL @ DOMER**  
A7 3/4" = 1'-0"

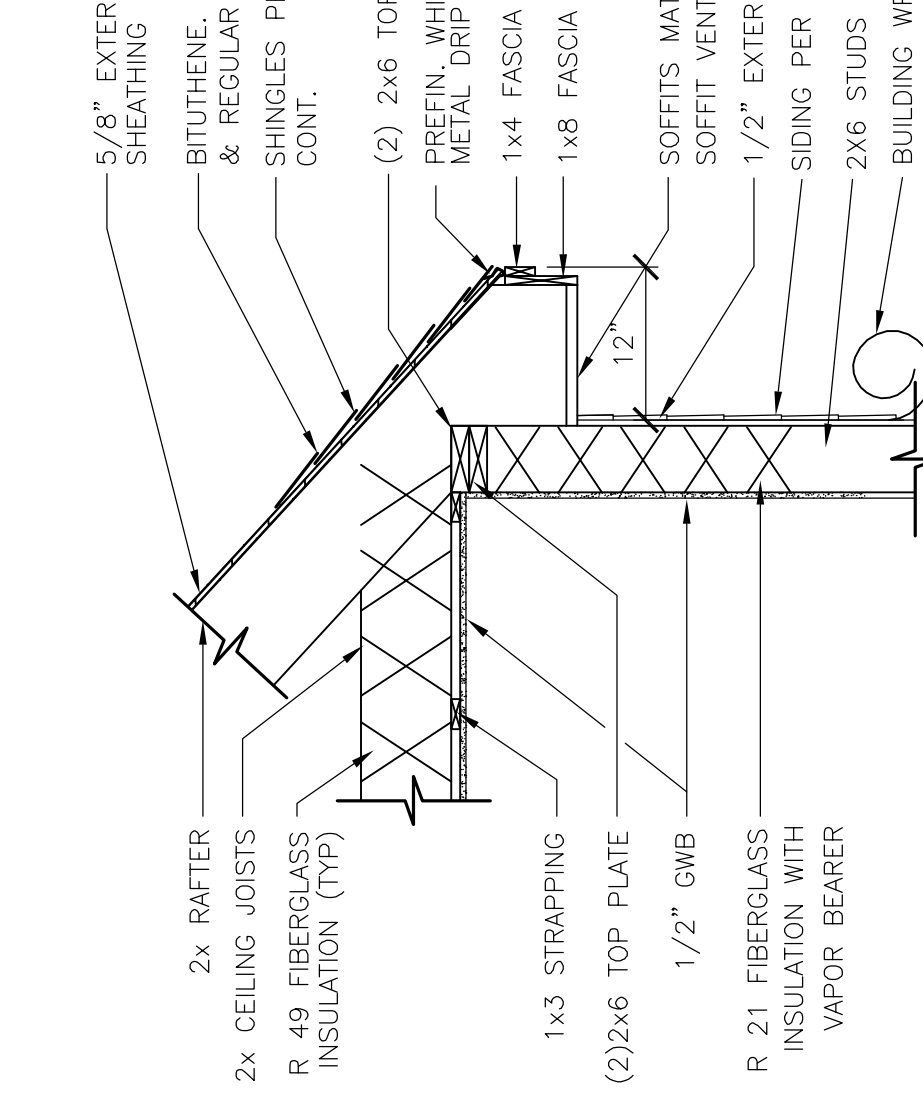

**8 SOFFIT DETAIL**  
A7 3/4" = 1'-0"

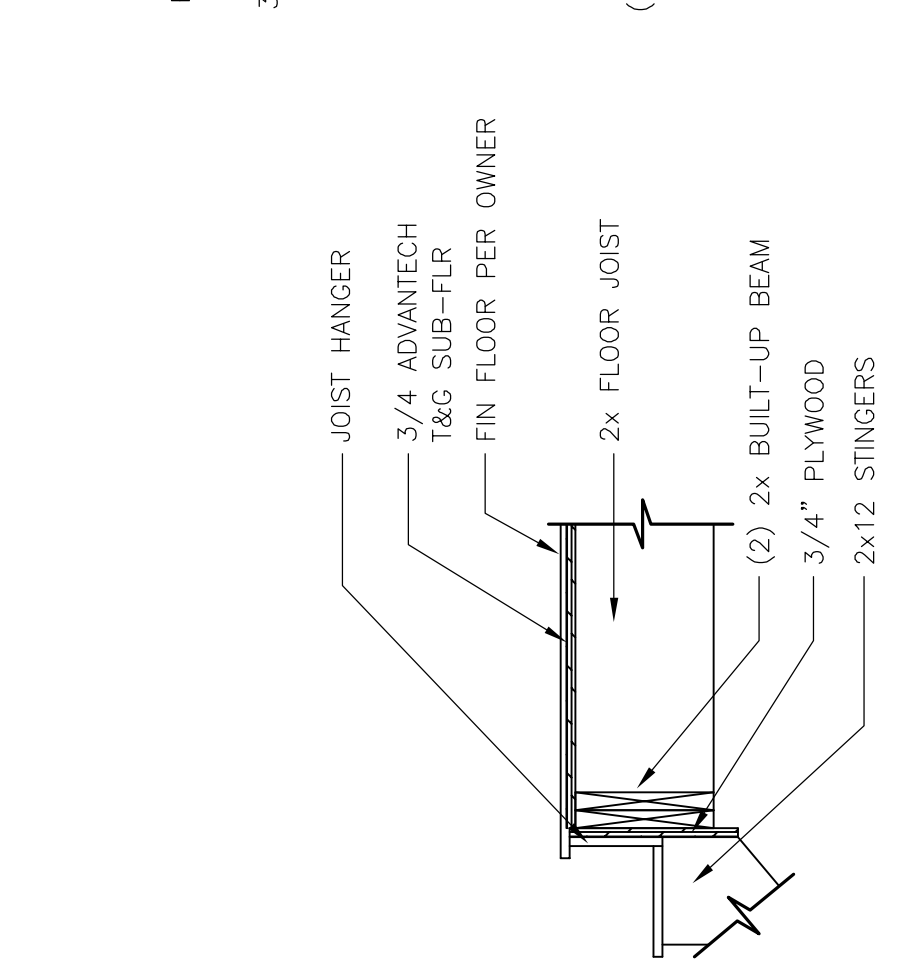

**9 STAIR ATTACHMENT DETAIL**  
A7 3/4" = 1'-0"

All surfaces (inside and outside) of steel columns shall be given a shop coat of rust-inhibitive paint, except for corrosion-resistant steel and steel treated with coatings to provide corrosion resistance. R407.3 Structural Requirements  
The columns shall be designed to prevent lateral displacement at the bottom end. Wood columns shall be not less than nominal size than 4"x4". Steel columns shall be not less than 3"-diameter. Schedule 40 pipe minimum. Manufacture in accordance with ASTM A513, Grade B or approved equivalent.

NOTE: DRAWINGS ARE PROVIDED FOR INFORMATIONAL PURPOSES ONLY. I, USER, USES, CONSTRUCTION, THE CONTRACTOR, SHALL BE RESPONSIBLE FOR LOCAL CODES, ORDINANCES, PERMITS, BUILDING DEPARTMENTS AND LOCAL OFFICES. EMPLOYEES OF CURRAN DRAFTING AND DESIGN, INC. ARE NOT REGISTERED ARCHITECTS OR ENGINEERS. ALL DIMENSIONS AND SPECIFICATIONS TO BE DERIVED BY CONTRACTOR BEFORE THE START OF CONSTRUCTION. CURRAN DRAFTING AND DESIGN, INC. IS NOT RESPONSIBLE FOR ANY CHANGES TO THE DRAWINGS MADE BY THE CLIENT AND/OR CONTRACTOR.

CLIENT \_\_\_\_\_  
CLIENT \_\_\_\_\_