

**City of Portland, Maine - Building or Use Permit Application**  
 389 Congress Street, 04101 Tel: (207) 874-8703, Fax: (207) 874-8716

Permit No: 09-1370	Issue Date:	CBL: 389 C009001
-----------------------	-------------	---------------------

Location of Construction: 77 Carter St	Owner Name: Littlefield Sara G	Owner Address: 77 Carter St	Phone:
Business Name:	Contractor Name: self	Contractor Address: Portland	Phone:
Lessee/Buyer's Name	Phone:	Permit Type: HVAC	Zone: R5

Past Use: Single Family	Proposed Use: Single Family / Install two 30" Lennox fire boxes inserted into the fireplaces.	Permit Fee: \$40.00	Cost of Work: \$1,500.00	CEO District: 5
Proposed Project Description: Install two 30" Lennox fire boxes inserted into the fireplaces.		FIRE DEPT: <input type="checkbox"/> Approved <input type="checkbox"/> Denied	INSPECTION: Use Group: R3 Type: HVAC Signature: Jm 12/2/09	
		PEDESTRIAN ACTIVITIES DISTRICT (P.A.D.) Action: <input type="checkbox"/> Approved <input type="checkbox"/> Approved w/Conditions <input type="checkbox"/> Denied Signature: Date:		

Permit Taken By: gg	Date Applied For: 12/02/2009	<b>Zoning Approval</b>		
------------------------	---------------------------------	------------------------	--	--

- This permit application does not preclude the Applicant(s) from meeting applicable State and Federal Rules.
- Building permits do not include plumbing, septic or electrical work.
- Building permits are void if work is not started within six (6) months of the date of issuance. False information may invalidate a building permit and stop all work..

Special Zone or Reviews <input type="checkbox"/> Shoreland <input type="checkbox"/> Wetland <input type="checkbox"/> Flood Zone <input type="checkbox"/> Subdivision <input type="checkbox"/> Site Plan Maj <input type="checkbox"/> Minor <input type="checkbox"/> MM <input type="checkbox"/> Date: Jm 12/2	Zoning Appeal <input type="checkbox"/> Variance <input type="checkbox"/> Miscellaneous <input type="checkbox"/> Conditional Use <input type="checkbox"/> Interpretation <input type="checkbox"/> Approved <input type="checkbox"/> Denied Date:	Historic Preservation <input checked="" type="checkbox"/> Not in District or Landmark <input checked="" type="checkbox"/> Does Not Require Review <input type="checkbox"/> Requires Review <input type="checkbox"/> Approved <input type="checkbox"/> Approved w/Conditions <input type="checkbox"/> Denied Date: Jm 12/2
--	--	--

**PERMIT ISSUED**

DEC - 2 2009

City of Portland

**CERTIFICATION**

I hereby certify that I am the owner of record of the named property, or that the proposed work is authorized by the owner of record and that I have been authorized by the owner to make this application as his authorized agent and I agree to conform to all applicable laws of this jurisdiction. In addition, if a permit for work described in the application is issued, I certify that the code official's authorized representative shall have the authority to enter all areas covered by such permit at any reasonable hour to enforce the provision of the code(s) applicable to such permit.

SIGNATURE OF APPLICANT	ADDRESS	DATE	PHONE
RESPONSIBLE PERSON IN CHARGE OF WORK, TITLE		DATE	PHONE

**BUILDING PERMIT INSPECTION PROCEDURES**

**Please call 874-8703 or 874-8693 (ONLY )**

**to schedule your inspections as agreed upon**

**Permits expire in 6 months, if the project is not started or ceases for 6 months.**

The Owner or their designee is required to notify the inspections office for the following inspections and provide adequate notice. Notice must be called in 48-72 hours in advance in order to schedule an inspection:

**By initializing at each inspection time, you are agreeing that you understand the inspection procedure and additional fees from a "Stop Work Order" and "Stop Work Order Release" will be incurred if the procedure is not followed as stated below.**

**A Pre-construction Meeting will take place upon receipt of your building permit.**

  X   **Final inspection required at completion of work.**

Certificate of Occupancy is not required for certain projects. Your inspector can advise you if your project requires a Certificate of Occupancy. All projects DO require a final inspection.

**If any of the inspections do not occur, the project cannot go on to the next phase, REGARDLESS OF THE NOTICE OR CIRCUMSTANCES.**

**CERIFICATE OF OCCUPANICES MUST BE ISSUED AND PAID FOR, BEFORE THE SPACE MAY BE OCCUPIED.**

James J. Jones  
Signature of Applicant/Designee

12-2-09  
Date

Thomas M. Markley  
Signature of Inspections Official

12/2/09  
Date

**City of Portland, Maine - Building or Use Permit**  
 389 Congress Street, 04101 Tel: (207) 874-8703, Fax: (207) 874-8716

<b>Permit No:</b> 09-1370	<b>Date Applied For:</b> 12/02/2009	<b>CBL:</b> 389 C009001
------------------------------	--	----------------------------

<b>Location of Construction:</b> 77 Carter St	<b>Owner Name:</b> Littlefield Sara G	<b>Owner Address:</b> 77 Carter St	<b>Phone:</b>
<b>Business Name:</b>	<b>Contractor Name:</b> self	<b>Contractor Address:</b> Portland	<b>Phone:</b>
<b>Lessee/Buyer's Name</b>	<b>Phone:</b>	<b>Permit Type:</b> HVAC	

<b>Proposed Use:</b> Single Family / Install two 30" Lennox fire boxes inserted into the fireplaces.	<b>Proposed Project Description:</b> Install two 30" Lennox fire boxes inserted into the fireplaces.
---	---

<b>Dept:</b> Zoning	<b>Status:</b> Approved with Conditions	<b>Reviewer:</b> Tom Markley	<b>Approval Date:</b> 12/02/2009
<b>Note:</b>			<b>Ok to Issue:</b> <input checked="" type="checkbox"/>
1) This is NOT an approval for an additional dwelling unit. You SHALL NOT add any additional kitchen equipment including, but not limited to items such as stoves, microwaves, refrigerators, or kitchen sinks, etc. Without special approvals. 2) This property shall remain a single family dwelling. Any change of use shall require a separate permit application for review and approval. 3) This permit is being approved on the basis of plans submitted. Any deviations shall require a separate approval before starting that work.			
<b>Dept:</b> Building	<b>Status:</b> Approved with Conditions	<b>Reviewer:</b> Tom Markley	<b>Approval Date:</b> 12/02/2009
<b>Note:</b>			<b>Ok to Issue:</b> <input checked="" type="checkbox"/>
1) The installation must comply with the State of Maine Gas Regulations. 2) Application approval based upon information provided by applicant. Any deviation from approved plans requires separate review and approval prior to work.			



LSVFSD-18



LSVFSD-24



LSVFSD-30

**SHADOWDANCE™ LOG SET BTU RATING**

Log Set Type	Millivolt Valve (VN, VP)	
	High Setting	Low Setting
18" Natural Gas	37,000	24,500
24" Natural Gas	37,000	24,500
30" Natural Gas	37,000	24,500
18" Propane	37,000	28,000
24" Propane	37,000	28,000
30" Propane	37,000	28,000

**PERFORMANCE INFORMATION**

Percent of Allowable Per ANSI Z21.11.2

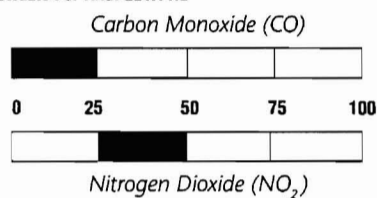

Test results by independent laboratories confirm that Shadowdance™ gas logs meet or exceed current and applicable nationally recognized standards and recommendations for indoor air quality and are among the cleanest-burning unvented products when measuring allowable levels of combustion byproducts such as carbon monoxide and nitrogen dioxide.

**MINIMUM FIREBOX DIMENSIONS**

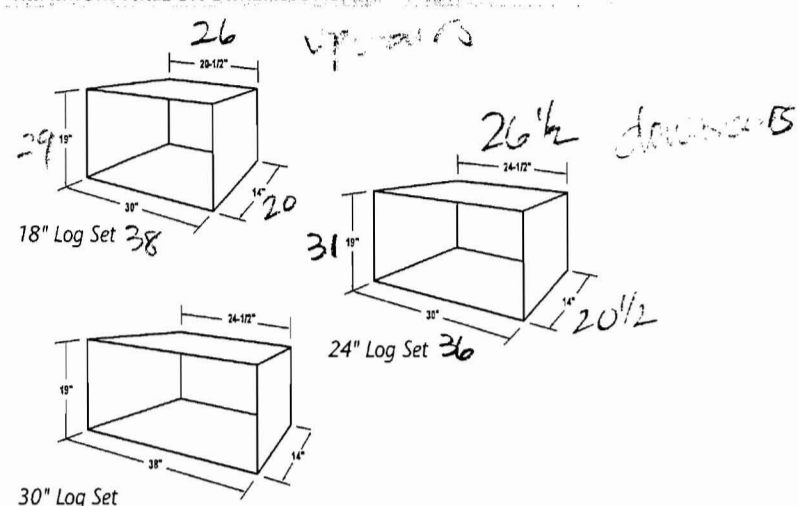

**PRODUCTS YOU CAN COUNT ON**

Lennox is committed to providing you with high-quality products. A qualified dealer can help you find the right product to give you years of comfort and enjoyment.



HEARTH PRODUCTS  
Innovation never felt so good.™

© Lennox Industries Inc. 2008

Visit us at [www.lennox.com](http://www.lennox.com), or contact us at 1-800-9-LENNOX.

785230M 05/08

**IMPORTANT NOTES:**

As with any heating appliance, fireplace or stove, this appliance is extremely hot during operation. Read and understand all operating instructions before using this appliance. For further information, consult your dealer.

Local conditions, such as elevation and choice of fuel will affect overall appearance of the fire and heating performance. Performance can also vary with home design and insulation, ceiling height, accessories chosen and appliance location.

Diagrams, illustrations and photographs are not to scale – consult installation instructions. Product designs, materials, dimensions, specifications, colors and prices are subject to change or discontinuance without notice.

This appliance complies with ANSI Z21.11.2A-1997 Unvented gas-fired room heater (U.S.) and ANSI Z21.60.1996/CGA 2.26.1996 Vented decorative appliance (U.S. and Canada).



Tested & Listed By  
**OTL**  
US  
OMNI-Test Laboratories, Inc.  
Beaverton Oregon USA

SHADOWDANCE™ GAS LOGS



Innovative logs, stacked on a glowing ember bed, produce authentic dancing flames for ambiance and classic comfort.

**LENNOX**

HEARTH PRODUCTS  
*Innovation never felt so good.™*

DAVE LENNOX  
*signature*  
COLLECTION



**Shadowdance™ 24" gas logs shown.**

■ Tall, dancing flames and a gorgeous, glowing ember bed are beautifully displayed in the Shadowdance™ dual-listed logs from the Dave Lennox *Signature™* Collection. Cast from real wood with exceptional detailing, these high-definition logs are beautiful to behold whether the fire is on or off. The dual-burner system provides taller, more realistic flames and can be adjusted to create the ideal atmosphere. Plus, while the ceramic ember bed radiates heat back into the room for enhanced comfort, its fixed-position design creates a more realistic appearance when the fire is off. Considerable in size, these logs proportionately fill existing fireplaces and complete the look of a vent-free or masonry fireplace, bringing warmth and ambiance to any room. ■





### STANDARD FEATURES

High-definition ceramic logs, molded from real wood, provide a realistic look and feel – burning or not

One-piece ceramic ember bed allows easy setup, helps radiate heat back into the living space and provides a more realistic appearance when the fire is off

Dual-burner system provides taller flames and a more realistic overall fire presentation

Variable flame control allows you to set flame height by reducing BTU input by up to 50%

Heavy-duty 5/8" diamond bar grate provides high-quality stability and durability

Oxygen Depletion Sensor monitors oxygen supply in the room and shuts off the unit if the amount of oxygen drops to an unsafe level

Log sets available to fit all Superior® vent-free universal fireboxes

Lava rock enhances realism

Dual-listed for flexible installation configurations – vented or vent-free

30" log set includes additional charred ember pieces

3-year limited warranty

### OPTIONAL ACCESSORIES

Standard or deluxe remote

Charred ember kit  
(optional for 18" and 24" log sets)



Remote control

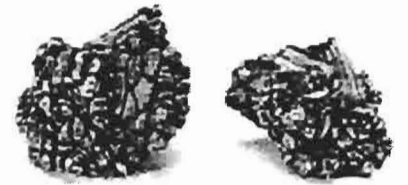

Charred ember kit  
(optional for 18" and 24" log sets)



**Shadowdance™ 18"** shown with optional charred ember kit



**Shadowdance 18"** shown



**Shadowdance 24"** shown



**Shadowdance 30"** shown



FILL IN AND SIGN WITH INK

# APPLICATION FOR PERMIT HEATING OR POWER EQUIPMENT

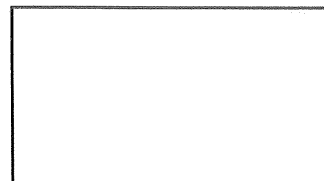

389 009

To the INSPECTOR OF BUILDINGS, PORTLAND, ME.

The undersigned hereby applies for a permit to install the following heating, cooking or power equipment in accordance with the Laws of Maine, the Building Code of the City of Portland, and the following specifications:

Location / CBL 77 Carter Street Use of Building Dwelling Date 12-2-09  
Name and address of owner of appliance Scott Glanville, Tina Forbes

Installer's name and address Champagne's Energy  
844 Old Post Rd, Arundel, ME Telephone (207) 283-1518

### Location of appliance:

- Basement
- Floor
- Attic
- Roof

### Type of Fuel:

- Gas
- Oil
- Solid

Appliance Name: 2 Lennox 30" firebox

U.L. Approved  Yes  No

Will appliance be installed in accordance with the manufacture's installation instructions?  Yes  No

IF NO Explain: \_\_\_\_\_

### The Type of License of Installer:

- Master Plumber # \_\_\_\_\_
- Solid Fuel # \_\_\_\_\_
- Oil # \_\_\_\_\_
- Gas # \_\_\_\_\_
- Other \_\_\_\_\_

### Type of Chimney:

Masonry Lined  
Factory built \_\_\_\_\_

Metal  
Factory Built U.L. Listing # \_\_\_\_\_

Direct Vent  
Type \_\_\_\_\_ UL# \_\_\_\_\_

### Type of Fuel Tank

- Oil
- Gas

Size of Tank 50 gal. for 2 fire places

Number of Tanks one

Distance from Tank to Center of Flame \_\_\_\_\_ feet.

Cost of Work: \$ 1500.00

Permit Fee: \$ 40.00

### Approved

### Approved with Conditions

Fire: \_\_\_\_\_

Ele.: \_\_\_\_\_

Bldg.: \_\_\_\_\_

See attached letter or requirement

Signature of Installer Tina Forbes - homeowner Inspector's Signature \_\_\_\_\_ Date Approved \_\_\_\_\_