

off Summit

City of Portland, Maine - Building or Use Permit Application
 389 Congress Street, 04101 Tel: (207) 874-8703, Fax: (207) 874-8716

Permit No. 020890	Issue Date: AUG 15 2002	CBL: 388A A037001
Location of Construction: 104 Frost Hill Rd	Owner Name: Muir Allan M & <i>B-3</i>	Owner Address: 104 Frost Hill Rd
Business Name:	Contractor Name: Applicant	Contractor Address: Portland
Lessee/Buyer's Name	Phone:	Permit Type: Additions - Dwellings
		Zone: <i>R-2</i>

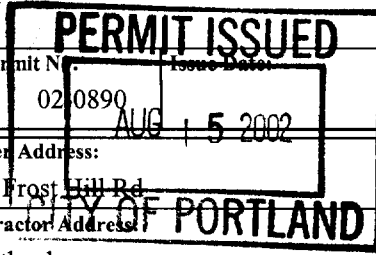

Past Use: Single Family	Proposed Use: Single Family
----------------------------	--------------------------------

Permit Fee: \$37.00	Cost of Work: \$1,500.00	CEO District: 2
FIRE DEPT: <i>N/A</i>	INSPECTION: Use Group: <i>R-3</i> Type: <i>SB</i>	
Signature:	Signature:	

Proposed Project Description:
 Addition of 12' x 24' Deck with stairs

PEDESTRIAN ACTIVITIES DISTRICT (P.A.D.)
 Action: Approved Approved w/Conditions Denied
 Signature: _____ Date: _____

Permit Taken By: gad	Date Applied For: 08/07/2002
-------------------------	---------------------------------

Zoning Approval		
1. This permit application does not preclude the Applicant(s) from meeting applicable State and Federal Rules. 2. Building permits do not include plumbing, septic or electrical work. 3. Building permits are void if work is not started within six (6) months of the date of issuance. False information may invalidate a building permit and stop all work..	Special Zone or Reviews <input type="checkbox"/> Shoreland <input type="checkbox"/> Wetland <input type="checkbox"/> Flood Zone <input type="checkbox"/> Subdivision <input type="checkbox"/> Site Plan Maj <input type="checkbox"/> Minor <input type="checkbox"/> MM <input type="checkbox"/> Date: <i>OK 8/13/02</i>	Zoning Appeal <input type="checkbox"/> Variance <input type="checkbox"/> Miscellaneous <input type="checkbox"/> Conditional Use <input type="checkbox"/> Interpretation <input type="checkbox"/> Approved <input type="checkbox"/> Denied Date: _____
	Historic Preservation <input checked="" type="checkbox"/> Not in District or Landmark <input type="checkbox"/> Does Not Require Review <input type="checkbox"/> Requires Review <input type="checkbox"/> Approved <input type="checkbox"/> Approved w/Conditions <input type="checkbox"/> Denied Date: _____	

CERTIFICATION

I hereby certify that I am the owner of record of the named property, or that the proposed work is authorized by the owner of record and that I have been authorized by the owner to make this application as his authorized agent and I agree to conform to all applicable laws of this jurisdiction. In addition, if a permit for work described in the application is issued, I certify that the code official's authorized representative shall have the authority to enter all areas covered by such permit at any reasonable hour to enforce the provision of the code(s) applicable to such permit.

SIGNATURE OF APPLICANT	ADDRESS	DATE	PHONE
RESPONSIBLE PERSON IN CHARGE OF WORK, TITLE		DATE	PHONE

DISPLAY THIS CARD ON PRINCIPAL FRONTAGE OF WORK CITY OF PORTLAND

BUILDING & INSPECTION

PERMIT

Permit Number: 020890

Please Read Application And Notes, If Any, Attached

This is to certify that Muir Allan M &/Applicant
has permission to Addition of 12' x 24' Deck with stairs
AT 104 Frost Hill Rd 388A A037001

provided that the person or persons, firm or corporation accepting this permit shall comply with all of the provisions of the Statutes of Maine and of the Ordinances of the City of Portland regulating the construction, maintenance and use of buildings and structures, and of the application on file in this department.

Apply to Public Works for street line and grade if nature of work requires such information.

Notification of inspection must be given and written permission procured before this building or part thereof is altered or closed-in. **HEAVY NOTICE IS REQUIRED.**

A certificate of occupancy must be procured by owner before this building or part thereof is occupied.

OTHER REQUIRED APPROVALS

Fire Dept. _____
Health Dept. _____
Appeal Board _____
Other _____
Department Name

Director - Building & Inspection Services

PENALTY FOR REMOVING THIS CARD

02-0898

All Purpose Building Permit Application

If you or the property owner owes real estate or personal property taxes or user charges on any property within the City, payment arrangements must be made before permits of any kind are accepted.

Location/Address of Construction: 104 Frost Hill Rd		
Total Square Footage of Proposed Structure	Square Footage of Lot	
Tax Assessor's Chart, Block & Lot Chart# 388 Block# AA Lot# 037	Owner: Allan M Muir	Telephone: 797. 8014
Lessee/Buyer's Name (If Applicable)	Applicant name, address & telephone: Allan M Muir same	Cost Of Work: \$ 3500 Fee: \$ 1,500 37-
Current use: <u>residence</u> <u>single family</u>		
If the location is currently vacant, what was prior use: _____		
Approximately how long has it been vacant: _____		
Proposed use: <u>deck replaced</u> <u>replace</u>		
Project description: <u>replace deck with joists and stairs</u>		
Contractor's name, address & telephone:		
Who should we contact when the permit is ready: <u>Allan Muir</u>		
Mailing address:		
We will contact you by phone when the permit is ready. You must come in and pick up the permit and review the requirements before starting any work, with a Plan Reviewer. A stop work order will be issued and a \$100.00 fee if any work starts before the permit is picked up. PHONE: 797. 8014		

IF THE REQUIRED INFORMATION IS NOT INCLUDED IN THE SUBMISSIONS THE PERMIT WILL BE AUTOMATICALLY DENIED AT THE DISCRETION OF THE BUILDING/PLANNING DEPARTMENT, WE MAY REQUIRE ADDITIONAL INFORMATION IN ORDER TO APPROVE THIS PERMIT.

I hereby certify that I am the Owner of record of the named property, or that the owner of record authorizes the proposed work and that I have been authorized by the owner to make this application as his/her authorized agent. I agree to conform to all applicable laws of this jurisdiction. In addition, if a permit for work described in this application is issued, I certify that the Code Official's authorized representative shall have the authority to enter all areas covered by this permit at any reasonable hour to enforce the provisions of the codes applicable to this permit.

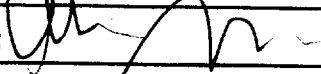
Signature of applicant: 	Date: 8-7-02
---	--------------

This is NOT a permit, you may not commence ANY work until the permit is issued. If you are in a Historic District you may be subject to additional permitting and fees with the Planning Department on the 4th floor of City Hall

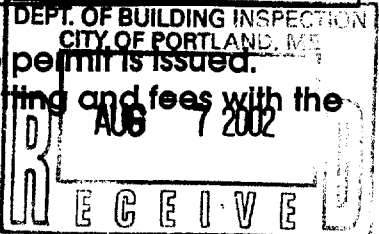

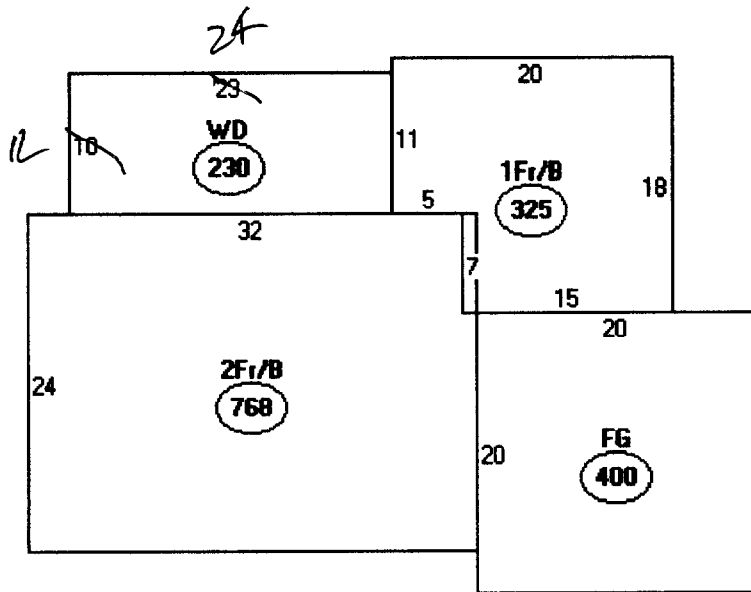

Descriptor/Area

A: 2Fr/B
768 sqft

B: WD
~~280~~ sqft 288

C: 1Fr/B
325 sqft

D: FG
400 sqft

1 2
768
288
325
400

1781
ok

10, 200' x 200' = 2040'



25' let back

FACSIMILE TRANSMITTAL SHEET

TO: ALAN MUIR	FROM: BOB COFFIN
COMPANY:	DATE: 7-18-02
FAX NUMBER: 791-1350	TOTAL NO. OF PAGES INCLUDING COVER: 8
PHONE NUMBER: 791-1365	SENDER'S REFERENCE NUMBER:
RE: DECK	YOUR REFERENCE NUMBER:

- URGENT
- FOR REVIEW
- PLEASE COMMENT
- PLEASE REPLY
- PLEASE RECYCLE

NOTES/COMMENTS:

Alan - The deck package info is attached. Please look it over & call if you have any questions.

Delivery - no charge - try to give us 2 day advance notice, if possible.

Contractors: TONN EMERY CEL 650-7312 (HE HAS SKETCH COPY)

DICK TORRES H. 846-9288/CEL. 831-8623

WILL PUSARO CEL 831-7933

(207)-846-5555 / FAX (207)-846-6127
258 MAIN STREET
YARMOUTH, MAINE 04096

Windham (207) 892-6711
409 Roosevelt Trail
Windham, ME 04062
1-800-360-6711 / Fax (207) 892-2948

Kennebunk (207) 985-6565
95 York Street
Kennebunk, ME 04043
1-800-296-6565 / Fax (207) 985-6194

Bargain Barn (207) 627-4453
Rte. 11, Casco, ME 04015
Fax (207) 627-6029

New Hampshire
1548 First NH Turnpike
Northwood, NH 03261
1-888-298-8899 / (603) 942-8877

Sanford (207) 324-4000
Junction Rt. 109 & 4
Sanford, ME 04073
Fax (207) 324-1218

Commercial Sales Division
1-800-838-6711 / Fax (207) 893-1719

Atlantic Kitchen Center
(207) 773-1227
Fax (207) 775-2850

Pittsfield (207) 487-6116
Pittsfield Industrial Park
Pittsfield, ME 04967
Fax (207) 487-5248

Installed Sales Division
1-800-360-6711

South Paris (207) 743-7946
223 Main Street
So. Paris, ME 04281
Fax (207) 743-5129

Casco (207) 627-4400
P.O. Box 299
Casco, ME 04015
1-800-471-4400 / Fax (207) 627-4100

Yarmouth (207) 846-5555
258 Main Street
Yarmouth, ME 04096
1-800-559-5564 / Fax (207) 846-6127

Construction Financing
(207)-627-4201 / Fax (207) 627-4513



BUILDING MATERIALS ESTIMATE

Prepared For: ALAN MUIR

Job Name: DECK 11'6" x 24'

Date: 7-18-02 Prepared By: BOB COFFIN

Cost of Materials:	=	\$ 1480.29
Shipping:	=	\$0.00
Sales Tax:	=	74.01
Total:	=	\$ 1554.28 NET

* Terms Governing Estimate:

- 1) Prices are guaranteed for 15 days unless otherwise specified in writing by your Hancock Lumber sales representative.
- 2) Prices are net unless otherwise specified in writing by your Hancock Lumber sales representative.
- 3) Payment terms are the 10th of the month following the month of the purchase unless otherwise specified in writing by your Hancock Lumber sales representative.
- 4) Our recommendation is that you supply your own material list to be priced. Hancock Lumber will create material lists per your specifications. However, material lists done by Hancock Lumber represent only our best estimate of materials and quantities needed to complete your project. Hancock Lumber assumes no responsibility for the accuracy of quantities.
- 5) If allowance figures have been used in this estimate they represent approximate costs. Allowance estimates are based only on past experiences with similar projects.
- 6) Prices of individual items are set with the assumption that you are interested in the entire material list. Hancock Lumber reserves the right to adjust prices if the material list is altered.
- 7) Hancock Lumber reserves the right to adjust prices based on unforeseen market circumstances.
- 8) Hancock Lumber has specialists available to assist you with your kitchen, bath and flooring designs and installation.
- 9) Hancock Lumber installs insulation and vinyl siding.

Manufacturing, Distribution & Construction Services for the 21st Century.

www.hancocklumber.com

Hancock Lumber

LOCATION: YARMOUTH

Standard quote

Phone: 846-5555

Fax: 846-6127

Sold to:

COFFIN/BOB

CASH SALES ONLY

YARMOUTH,

Ship to:

ALAN MUIR H.797-8014

104 FROST HILL RD

PORTLAND,

Account Ord Date Del Date Ent Order # Written By
COFF1008 07/18/02 16# 603656 Bob Coffin

Item Cd	Qty	Description	Ext Qty	Price	Net Amount
1 85TCUT	16 LFT	8" BUILDERS TUBE	16.000	0.620 LFT	9.92
2 80C	11 EA	800 REDI MIX CONCRETE	11.000	4.240 EA	46.64
3 10AB	4 EA	10" ANCHOR BOLT	4.000	0.340 EA	1.36
4 AB66	4 EA	SIMPSON ADJ.POST BASE AB66	4.000	14.000 EA	56.00
5 660PT	4 EA	6X6-8 PT	96.000	871.130 MBF	83.63
6 21012PT	3 EA	2X10-12 PT	60.000	703.610 MBF	42.22
7 HF	32 EA	HILLMAN FASTENERS 3/8"X 4 1/2" GALV LAG W/WASHER	32.000	0.760 EA	24.32
9 2100PT	2 EA	2X10-8 PT	26.670	612.020 MBF	16.32
10 21016PT	2 EA	2X10-16 PT	53.330	627.950 MBF	33.49
11 21010PT	1 EA	2X10-10 PT	16.670	695.950 MBF	11.60
12 240PT1	1 EA	2X4-8 PT #1	5.330	704.980 MBF	3.76
13 2412PT1	1 EA	2X4-12 PT #1	8.000	626.840 MBF	5.01
14 208PT	4 EA	2X8-8 PT	42.670	575.470 MBF	24.56
15 2810PT	3 EA	2X8-10 PT	40.000	640.960 MBF	25.64
15 2812PT	16 EA	2X8-12 PT	256.000	661.180 MBF	169.26
17 5468AC1	19 EACH	5/4X6X8' #1 PT - ORGANIC	95.000	1259.410 MBF	119.64
18 54612AC1	29 EACH	5/4X6X12' #1 PT - ORGANIC	217.500	1247.350 MBF	271.30
19 54616AC1	16 EACH	5/4X6X16' #1 PT - ORGANIC	160.000	1307.620 MBF	209.22
20 44BACQ	3 EACH	4X4X8' #1 PT - ORGANIC	32.000	878.140 MBF	28.10
21 3PTBACQ	78 EACH	3' PT BALUSTER - ORGANIC	78.000	0.950 EACH	74.10
22 CDRTB212	1 EA	12' CEDAR RAIL	1.000	40.490 EA	40.49
23 4PTBACQ	18 EACH	4' PT BALUSTER - ORGANIC	18.000	1.220 EACH	21.96
24 21210PT	3 EA	2X12-10 PT	60.000	682.430 MBF	40.95
25 1612PT	3 EA	1X6-12' PT	18.000	1195.910 MBF	21.53
26 1250AF	1 EACH	50' ROL 12"ALUM.FLASKING	1.000	14.810 EACH	14.81
27 5P166CN	3 BX	50' BOX 16D GALV. COMM NAIL	3.000	4.000 BX	12.00
28 5P2SCS	2 EACH	5# 2" CERAMIC SQ. SCREW	2.000	13.500 EACH	27.00
29 5P212SCS	1 EACH	5# 2 1/2 CERAMIC SQ. SCREW	1.000	12.550 EACH	12.55
30 HF	18 EA	HILLMAN FASTENERS 3/8"X 3 1/2" GALV LAG W/WASHER	18.000	0.630 EA	11.34
32 5043735	2 EA	6" GALV. HD STRAP HINGE	2.000	10.760 EA	21.52

Sub-Total 1480.24
Sales Tax 74.01

TOTAL 1554.25



Brookway-Smith Company

Brosco Architectural Group

Serving Greater Northeast Architects since 1890

Office and Exhibit Area:
148 DASCONE ROAD
(Route 93 - Exit 42)
ANDOVER, MA 01810

800-225-7912
FAX (24 hours) 800-242-4533

QUOTE #603658
APPROX.
2705F



DATE 7-19-02 JOB ALAN MUIR

ITEM	QUANTITY	DESCRIPTION	
SIGNATURE	4/4'	8" S.T.	
CEMENT	11	80# SAKRETE	
ANCHOR BOLTS	4	10" A.B.	
POST BASE	4	AB 6x6	
POSTS	4	6x6x8 PT	
LEDGER	3	2x10x12 PT	
BEAM + LEDGER BOLTS	40	3/8 x 4 1/2 GALV LOG WASHER	CHECK: MAY BE 2x12! (2) EVERY 3' ON LEDGER
MAIN BEAMS	2/8' 2/16'	2x10 PT	
RIM JOISTS	1	2x10x10 PT	
JOIST LEDGERS	1/8' 1/12	2x4 PT	TIP IN HALF INCLUDES BLOCKING
JOISTS	4/8' 3/10' 1 1/2	2x8 PT	
* DECKING	1 1/8' 1 1/12' 1 1/16'	5/4x6 PT-*	* TOTALS 1 1/8', 2 1/12', 1 1/16'
* RAILS TOP & SIDE	3/8' 1/2	" *	
RAIL POSTS	3	4x4 PT	ORGANIC P.T.
BALUSTERS	78	3' PT	
STAIR RAIL	1	12' CEDAR ← CEDAR	
STAIR BALUSTERS	18	4' PT	2/STEP
* STAIR TREADS	5	5/4x6x12 PT *	
STRINGERS	3	2x12x10 PT	
STEP RISERS	3	1x6x12 PT	
HARDWARE			
FLASHING	50'	1x12 ALUM.	
FRAMING NAILS	15 #	16d GALV	
DECK SCREWS	10 #	2" CERAMIC COATED	
RAIL SCREWS	5 #	2 1/2" " "	
RAIL POST BOLTS	18	3/8 x 3 1/2 GALV LOG WASHER	
STEP HINGES	2 PR	6" STRAP 5043735	

Available to serve you with Budget Prices, Window Detailing and Spec Writing



ENTRY DOOR SYSTEM
Wood and Steel
Hinged French Patio Doors

Andersen "Rain Sensitized"
Automatic Closing
ROOF WINDOWS

DATE 5-10-00 JOB HANCOCK LUMBER

DECK HANDRAIL ~~DETAILS~~

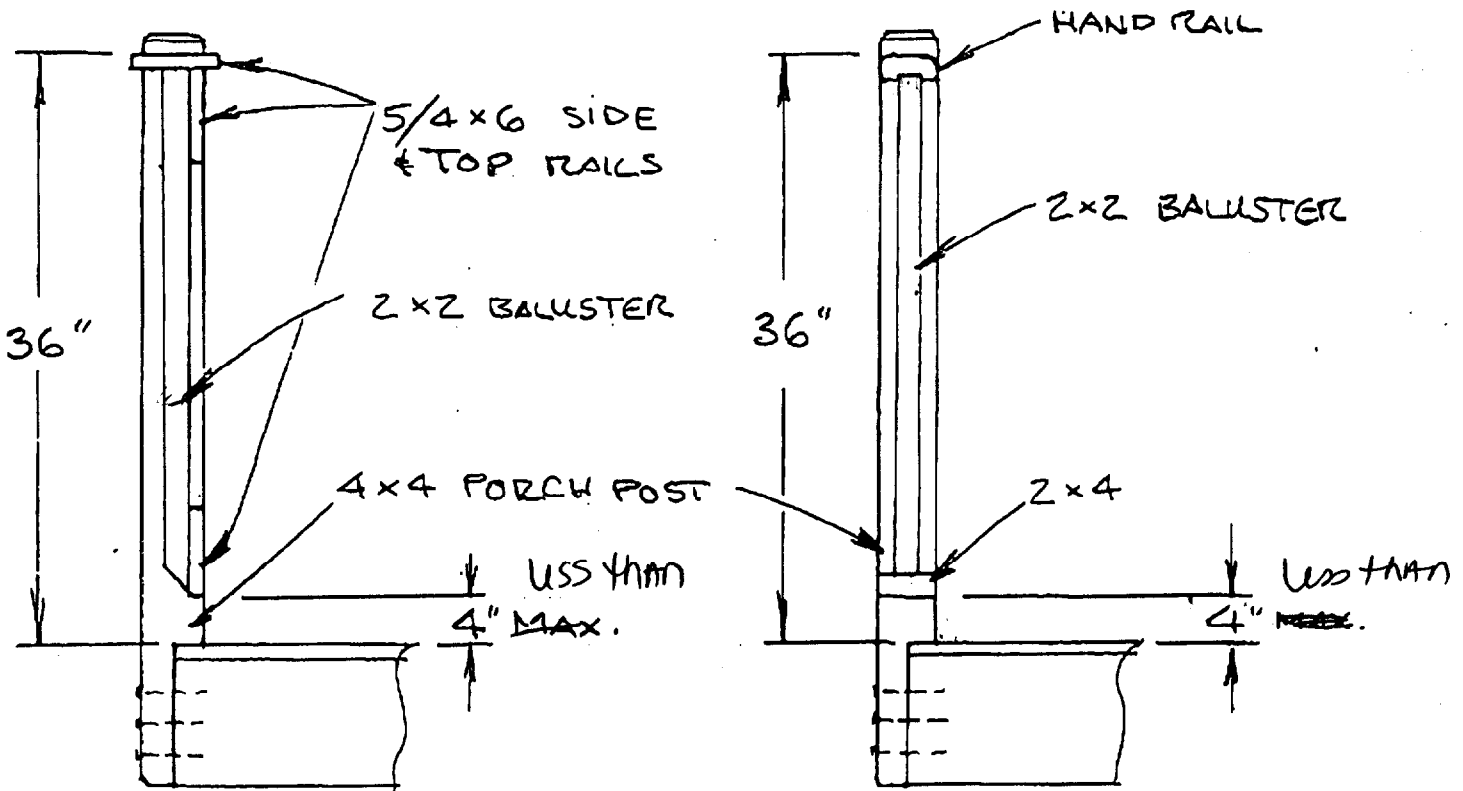

SYSTEM A

SYSTEM B

BE SURE TO CHECK LOCAL BUILDING CODES FOR RAILING REQUIREMENTS.

HANCOCK LUMBER
BOB COFFIN

Available to serve you with Budget Prices, Window Detailing and Spec Writing

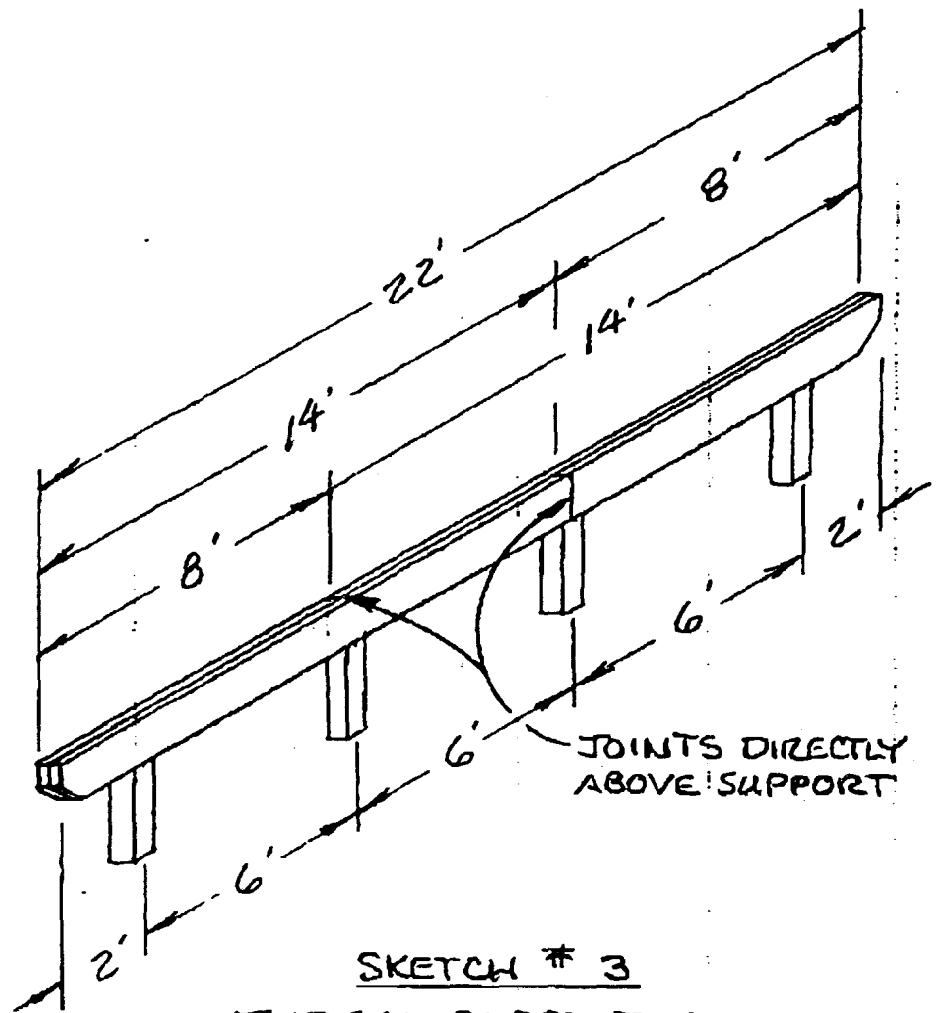

SKETCH # 3
TYPICAL SUPPORT BEAM

HANCOCK LUMBER
BOB COFFIN 2-4-02
SCALE: NONE

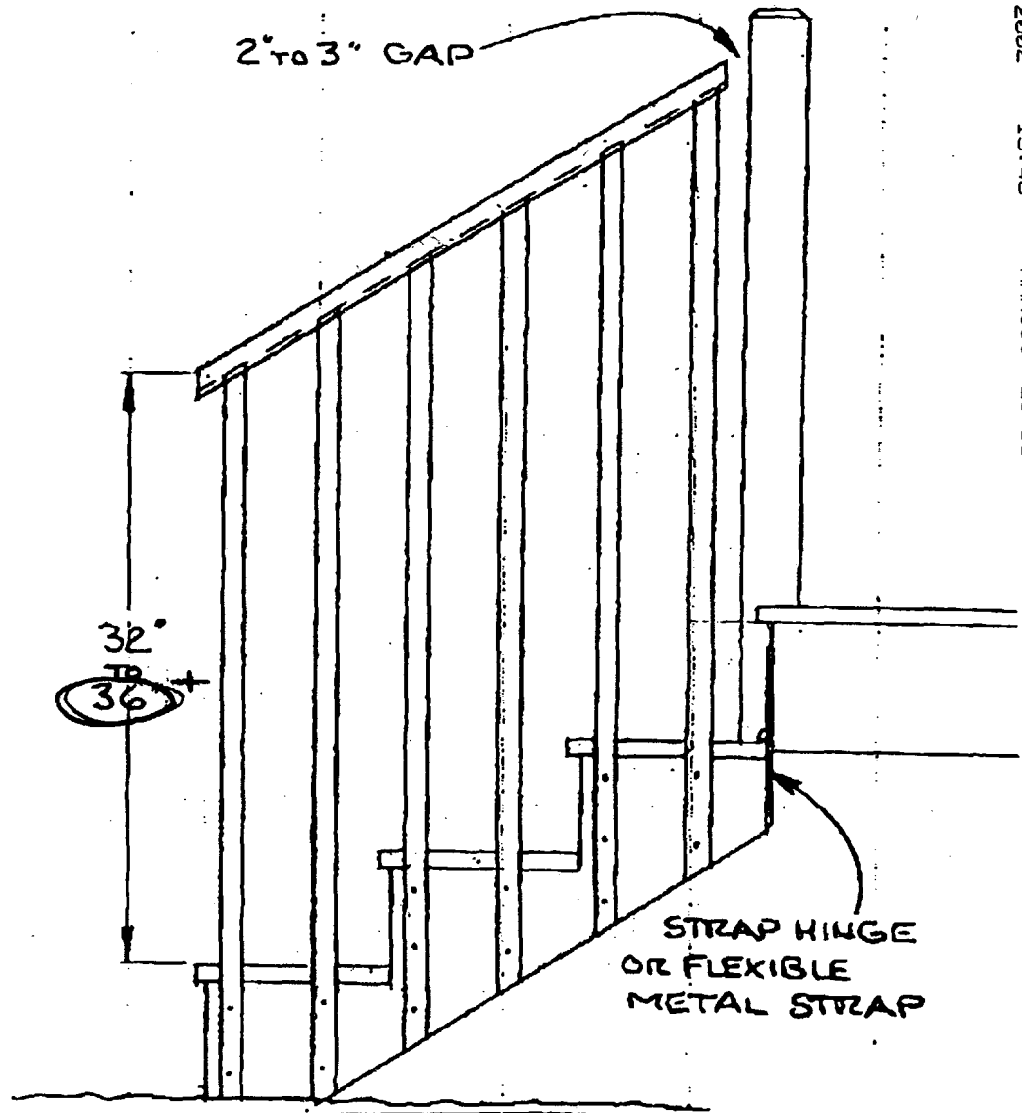

SKETCH #4 "FLOATING" STEPS

stairs 7 3/4" rise
10" tread

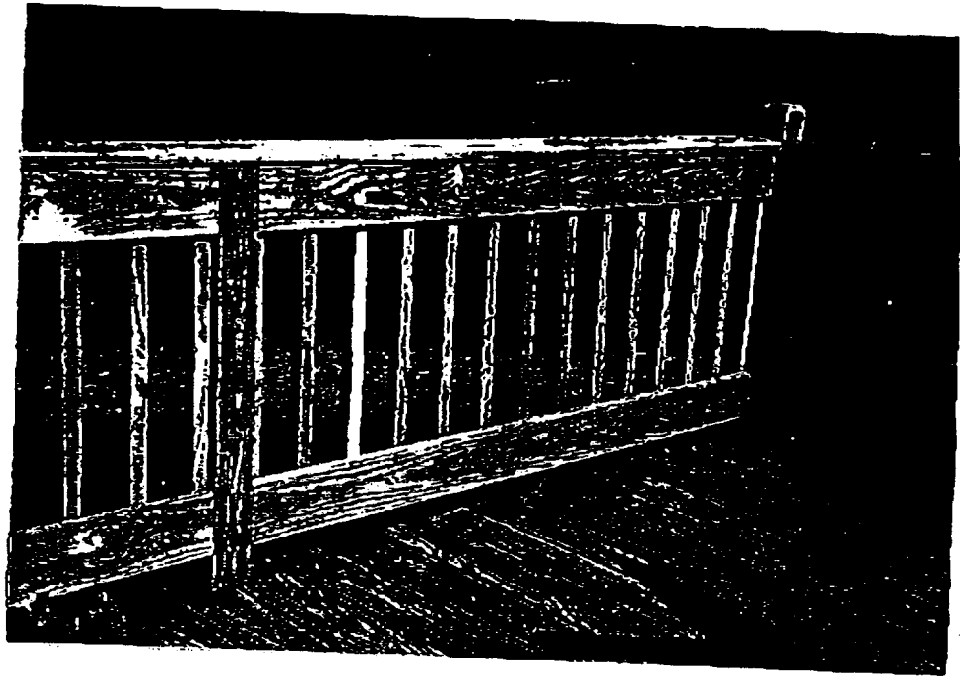
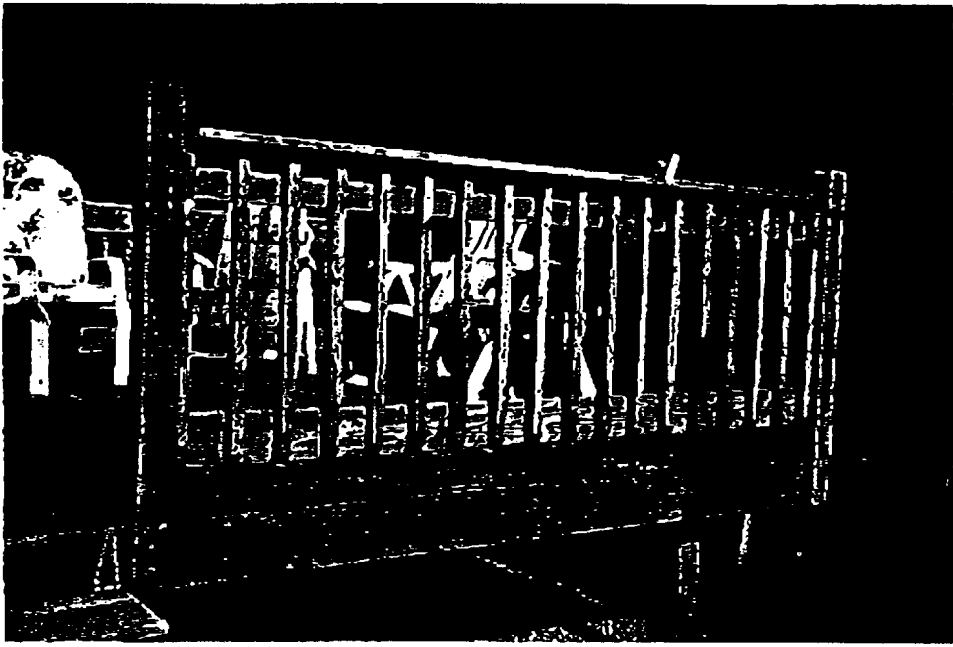

existing
to be replaced
"rotting"

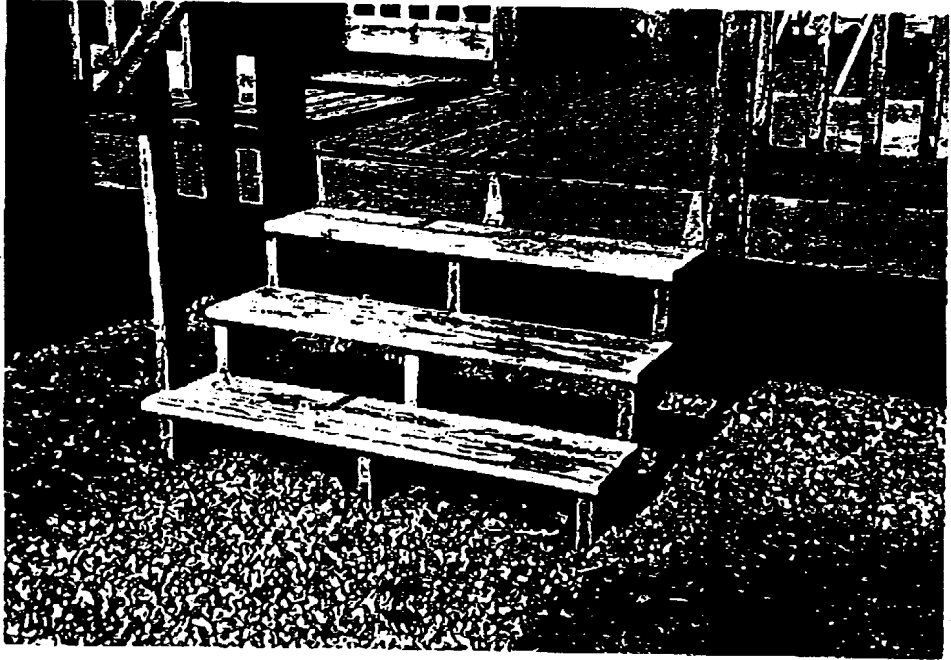

HOUSE

HOUSE

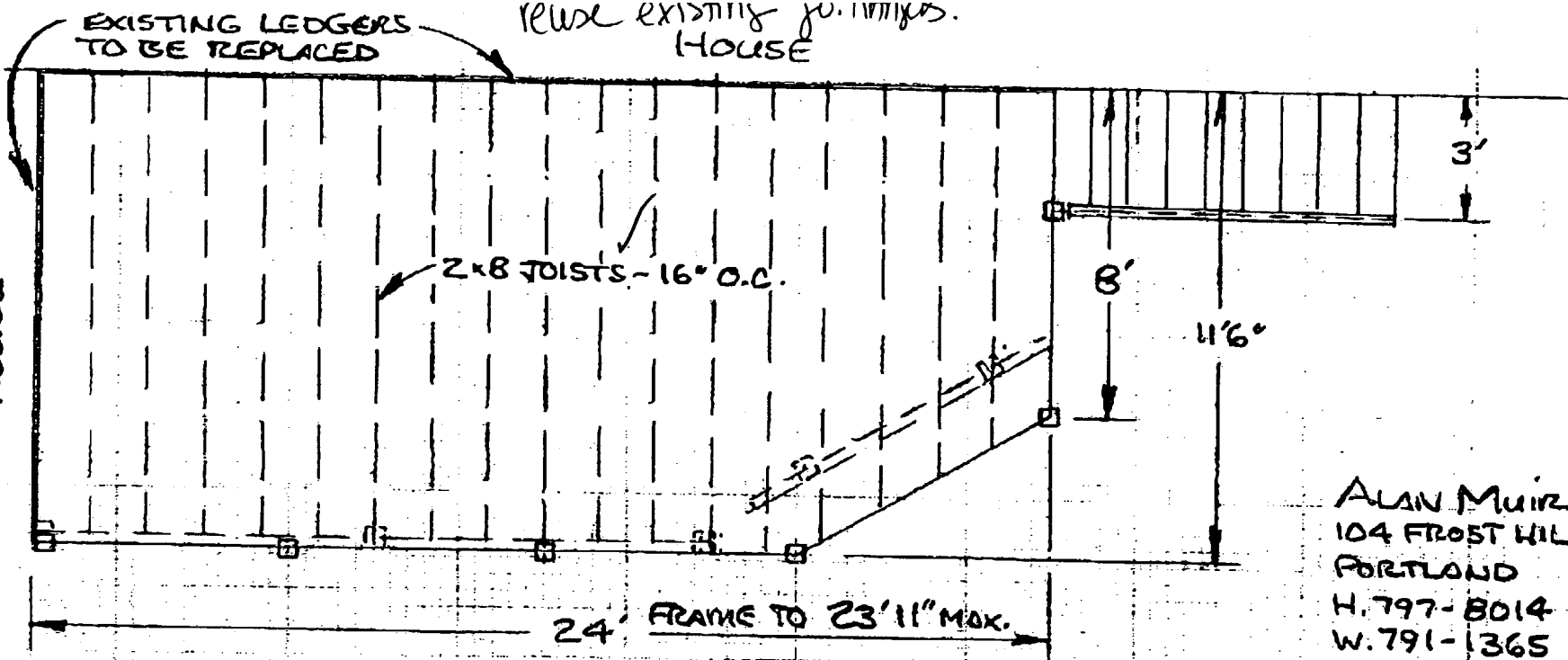

EXISTING LEDGERS TO BE REPLACED

REUSE EXISTING JOISTS. HOUSE

2x8 JOISTS - 16" O.C.

24' FRAME TO 23'11" MAX.

RAIL SYSTEM: A - SEE SKETCH & PHOTO

BALLISTERS 5" O.C. ±

8' APPROX.

CELLAR DOOR

6x6 PT

6'

8" SONOTUBES 4' IN GROUND

6'9" APPROX.

SEE STAIR SKETCH

ALAN MUIR
 104 FROST HILL RD
 PORTLAND
 H. 797-8014
 W. 791-1365

CHECK LOCAL BUILDING CODES

HANCOCK LUMBER
 BOB COFFIN 7-18-02
 SCALE: 1/4" = 12" APPROX.

BUILDING PERMIT INSPECTION PROCEDURES

Please call 874-8703 or ~~874-8693~~ to schedule your inspections as agreed upon

Permits expire in 6 months, if the project is not started or ceases for 6 months.

The Owner or their designee is required to notify the inspections office for the following inspections and provide adequate notice. Notice must be called in 48-72 hours in advance in order to schedule an inspection:

By initializing at each inspection time, you are agreeing that you understand the inspection procedure and additional fees from a "Stop Work Order" and "Stop Work Order Release" will be incurred if the procedure is not followed as stated below.

JB **Pre-construction Meeting:** Must be scheduled with your inspection team upon receipt of this permit. Jay Reynolds, Development Review Coordinator at 874-8632 must also be contacted at this time, before any site work begins on any project other than single family additions or alterations.

AW **Footing/Building Location Inspection:** Prior to pouring concrete

NA **Re-Bar Schedule Inspection:** Prior to pouring concrete

NA **Foundation Inspection:** Prior to placing ANY backfill

NA **Framing/Rough Plumbing/Electrical:** Prior to any insulating or drywalling

AW **Final/Certificate of Occupancy:** Prior to any occupancy of the structure or use. NOTE: There is a \$75.00 fee per inspection at this point.

Certificate of Occupancy is not required for certain projects. Your inspector can advise you if your project requires a Certificate of Occupancy. All projects DO require a final inspection

AW **If any of the inspections do not occur, the project cannot go on to the next phase, REGARDLESS OF THE NOTICE OR CIRCUMSTANCES.**

NA **CERIFICATE OF OCCUPANICES MUST BE ISSUED AND PAID FOR, BEFORE THE SPACE MAY BE OCCUPIED**

[Signature]
Signature of applicant/designee

8/20/02
Date

[Signature]
Signature of Inspections Official

8/20/02
Date

CBL: 388 AA037 Building Permit #: 020890