

**City of Portland, Maine - Building or Use Permit Application**

389 Congress Street, 04101 Tel: (207) 874-8703, Fax: (207) 874-8716

Permit No: 10-0408	Issue Date:	CBL: 338 L010001
-----------------------	-------------	---------------------

Location of Construction: 10 EASTLAWN RD	Owner Name: BRUCE HEIDI M	Owner Address: 10 EASTLAWN RD	Phone:
Business Name:	Contractor Name: Mainly Plumbing & Heating	Contractor Address: 674 Main Street Gorham	Phone: 2078544969
Lessee/Buyer's Name	Phone:	Permit Type: HVAC	Zone: R-3

Past Use: Single Family Home	Proposed Use: Single Family Home - install a Baxi HT - 380 natural gas in Basement	Permit Fee: \$110.00	Cost of Work: \$8,800.00	CEO District: 5
		FIRE DEPT: <input type="checkbox"/> Approved <input checked="" type="checkbox"/> Denied <i>MA</i>	INSPECTION: Use Group: HVAC Type: <i>State Eng Regs</i>	

Proposed Project Description: install a Baxi HT - 380 natural gas in Basement	Signature: <i>[Signature]</i>	Signature: <i>[Signature]</i>
PEDESTRIAN ACTIVITIES DISTRICT (P.A.D.)		
Action: <input type="checkbox"/> Approved <input type="checkbox"/> Approved w/Conditions <input type="checkbox"/> Denied		
Signature:		Date:

Permit Taken By: Idobson	Date Applied For: 04/28/2010	<b>Zoning Approval</b>
-----------------------------	---------------------------------	------------------------

- This permit application does not preclude the Applicant(s) from meeting applicable State and Federal Rules.
- Building permits do not include plumbing, septic or electrical work.
- Building permits are void if work is not started within six (6) months of the date of issuance. False information may invalidate a building permit and stop all work..

<b>Special Zone or Reviews</b> <input type="checkbox"/> Shoreland <input type="checkbox"/> Wetland <input type="checkbox"/> Flood Zone <input type="checkbox"/> Subdivision <input type="checkbox"/> Site Plan Major <input type="checkbox"/> Minor <input type="checkbox"/> MM <input type="checkbox"/> Date: <i>5/12/10</i>	<b>Zoning Appeal</b> <input type="checkbox"/> Variance <input type="checkbox"/> Miscellaneous <input type="checkbox"/> Conditional Use <input type="checkbox"/> Interpretation <input type="checkbox"/> Approved <input type="checkbox"/> Denied Date: <i>5/12/10</i>	<b>Historic Preservation</b> <input checked="" type="checkbox"/> Not in District or Landmark <input type="checkbox"/> Does Not Require Review <input type="checkbox"/> Requires Review <input type="checkbox"/> Approved <input type="checkbox"/> Approved w/Conditions <input type="checkbox"/> Denied Date: <i>[Signature]</i>
--	--	---

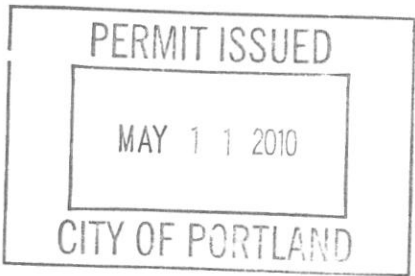

**CERTIFICATION**

I hereby certify that I am the owner of record of the named property, or that the proposed work is authorized by the owner of record and that I have been authorized by the owner to make this application as his authorized agent and I agree to conform to all applicable laws of this jurisdiction. In addition, if a permit for work described in the application is issued, I certify that the code official's authorized representative shall have the authority to enter all areas covered by such permit at any reasonable hour to enforce the provision of the code(s) applicable to such permit.

SIGNATURE OF APPLICANT	ADDRESS	DATE	PHONE
RESPONSIBLE PERSON IN CHARGE OF WORK, TITLE		DATE	PHONE

**City of Portland, Maine - Building or Use Permit**

389 Congress Street, 04101 Tel: (207) 874-8703, Fax: (207) 874-8716

Permit No: 10-0408	Date Applied For: 04/23/2010	CBL: 338 L010001
-----------------------	---------------------------------	---------------------

Location of Construction: 10 EASTLAWN RD	Owner Name: BRUCE HEIDI M	Owner Address: 10 EASTLAWN RD	Phone:
Business Name:	Contractor Name: Mainely Plumbing & Heating	Contractor Address: 674 Main Street Gorham	Phone (207) 854-4969
Lessee/Buyer's Name	Phone:	Permit Type: HVAC	

Proposed Use: Single Family Home - install a Baxi HT - 380 natural gas in Basement	Proposed Project Description: install a Baxi HT - 380 natural gas in Basement
---	--

**Dept:** Zoning      **Status:** Approved with Conditions      **Reviewer:** Marge Schmuckal      **Approval Date:** 04/26/2010

**Note:** **Ok to Issue:** ✓

- 1) Separate permits shall be required for future decks, sheds, pools, and/or garages.
- 2) This is NOT an approval for an additional dwelling unit. You SHALL NOT add any additional kitchen equipment including, but not limited to items such as stoves, microwaves, refrigerators, or kitchen sinks, etc. Without special approvals.
- 3) This property shall remain a single family dwelling. Any change of use shall require a separate permit application for review and approval.
- 4) This permit is being approved on the basis of plans submitted. Any deviations shall require a separate approval before starting that work.

**Dept:** Building      **Status:** Approved with Conditions      **Reviewer:** Tammy Munson      **Approval Date:** 05/10/2010

**Note:** **Ok to Issue:** ✓

- 1) The installation must comply with the State of Maine Gas Regulations.



# CITY OF PORTLAND, MAINE

Department of Building Inspections

## Original Receipt

4.26 20 10

Received from Mainely P&H

Location of Work 10 East Main

Cost of Construction \$ \_\_\_\_\_ Building Fee: \_\_\_\_\_

Permit Fee \$ \_\_\_\_\_ Site Fee: \_\_\_\_\_

Certificate of Occupancy Fee: \_\_\_\_\_

Total: 110

Building (IL) \_\_\_\_\_  Plumbing (I5) \_\_\_\_\_  Electrical (I2) \_\_\_\_\_  Site Plan (U2) \_\_\_\_\_

Other 110AC

CBL: 338 L 10

Check #: 28256 Total Collected \$ 110

**No work is to be started until permit issued.  
Please keep original receipt for your records.**

Taken by: [Signature]

WHITE - Applicant's Copy  
YELLOW - Office Copy  
PINK - Permit Copy



FILL IN AND SIGN WITH INK

# APPLICATION FOR PERMIT HEATING OR POWER EQUIPMENT

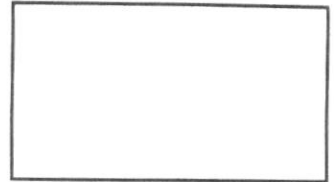

To the INSPECTOR OF BUILDINGS, PORTLAND, ME.

The undersigned hereby applies for a permit to install the following heating, cooking or power equipment in accordance with the Laws of Maine, the Building Code of the City of Portland, and the following specifications:

Location / CBL 10 Eastman St. Use of Building Single Family Date 4/20/10  
Name and address of owner of appliance Harold Bruce

Installer's name and address Marilyn Potts 674 Main St.  
Cashem, ME 04038 Telephone 854-4969

### Location of appliance:

- Basement  Floor
- Attic  Roof

### Type of Fuel:

- Gas  Oil  Solid

Appliance Name: Bears HT-380

U.L. Approved  Yes  No

Will appliance be installed in accordance with the manufacture's installation instructions?  Yes  No

IF NO Explain: \_\_\_\_\_

### The Type of License of Installer:

- Master Plumber # \_\_\_\_\_
- Solid Fuel # \_\_\_\_\_
- Oil # \_\_\_\_\_
- Gas # PNT347
- Other \_\_\_\_\_

### Type of Chimney:

- Masonry Lined  
Factory built \_\_\_\_\_

- Metal  
Factory Built U.L. Listing # \_\_\_\_\_

- Direct Vent  
Type Concentric Coaxial UL# \_\_\_\_\_

### Type of Fuel Tank

- Oil
- Gas Natural

Size of Tank \_\_\_\_\_

Number of Tanks \_\_\_\_\_

Distance from Tank to Center of Flame \_\_\_\_\_ feet.

Cost of Work: \$ 8800

Permit Fee: \$ 110

RECEIVED

APR 23 2010

Dept. of Building Inspections  
City of Portland Maine

### Approved

### Approved with Conditions

Fire: \_\_\_\_\_

Ele.: \_\_\_\_\_

Bldg.: \_\_\_\_\_

- See attached letter or requirement

Inspector's Signature \_\_\_\_\_

Date Approved \_\_\_\_\_

Signature of Installer \_\_\_\_\_

White - Inspection    Yellow - File    Pink - Applicant's    Gold - Assessor's Copy