

1 DECK BRACING
 Scale: 3/4" = 1'-0"

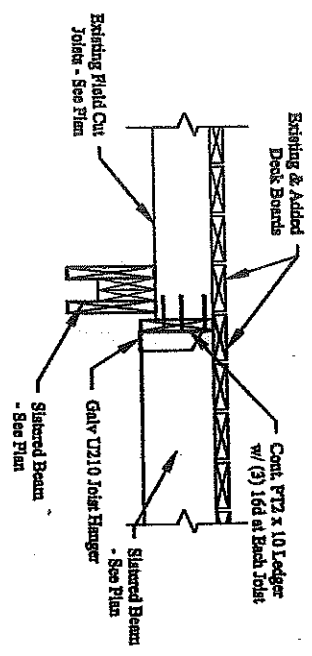

2 DECK @ EXIST. DECK
 Scale: 3/4" = 1'-0"

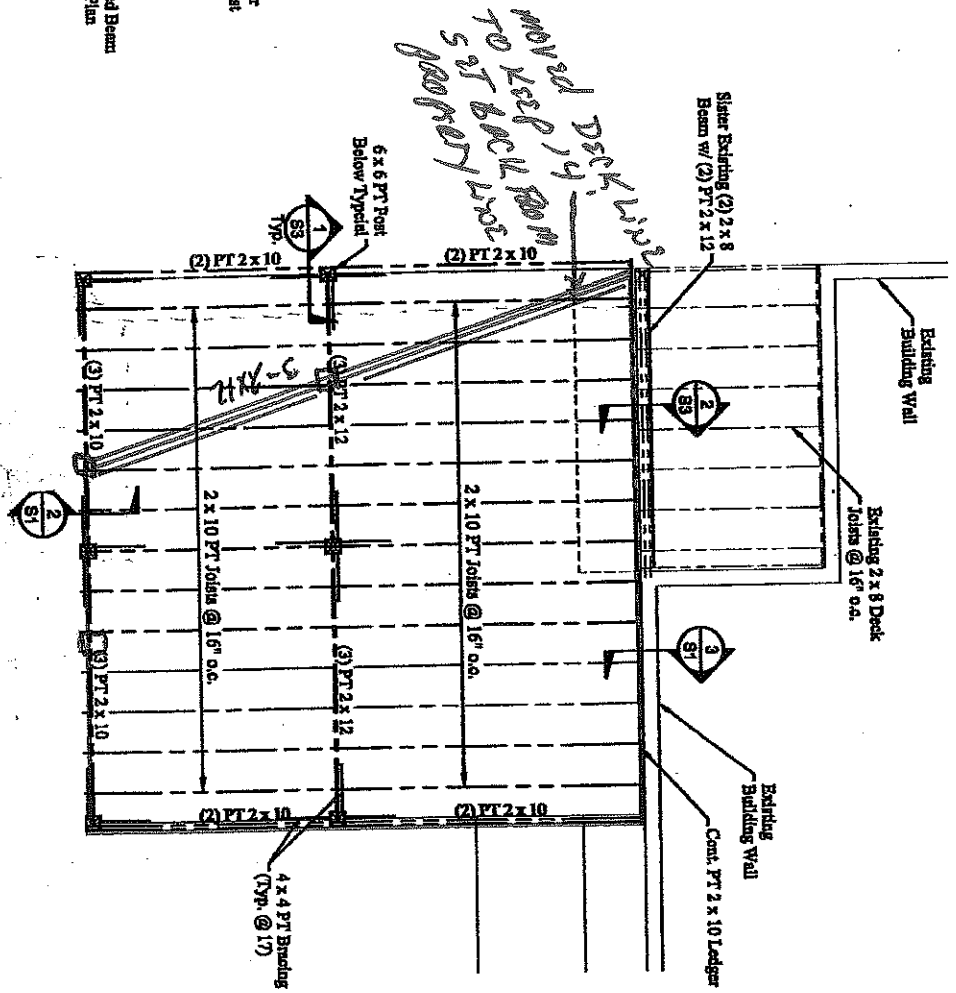

Handwritten note: Moved Deck Joist to 1st floor 5' 0" back from 5' 0" from post.

- NOTES:**
1. See structural notes sheet S1.
 2. Field verify all existing conditions and dimensions.
 3. Provide flashing to existing wall sheathing at ledger.
 4. Spike all buildup beams with 3 rows of galv. 16d nails @ 12" o.c.
- Deck Framing Plan
 Scale: 1/2" = 1'-0"

STATE OF MAINE
LARRY A. WICKROSK
 ENGINEER
 No. 5988

Project No: 01215
 Design By: Larry Wickrosc, P.E.
 Date: 07-20-2015

S3
 of 3

Rapolla Residence Deck
 15 Alice Court, Portland, Maine

EDP
 ENGINEERING DESIGN PROFESSIONALS
 Consulting Engineers
 P.O. BOX 693, FREEPORT, MAINE 04032 (207) 862-5825