

1 BASEMENT FDN. WALL
Scale: 1/2" = 1'-0"

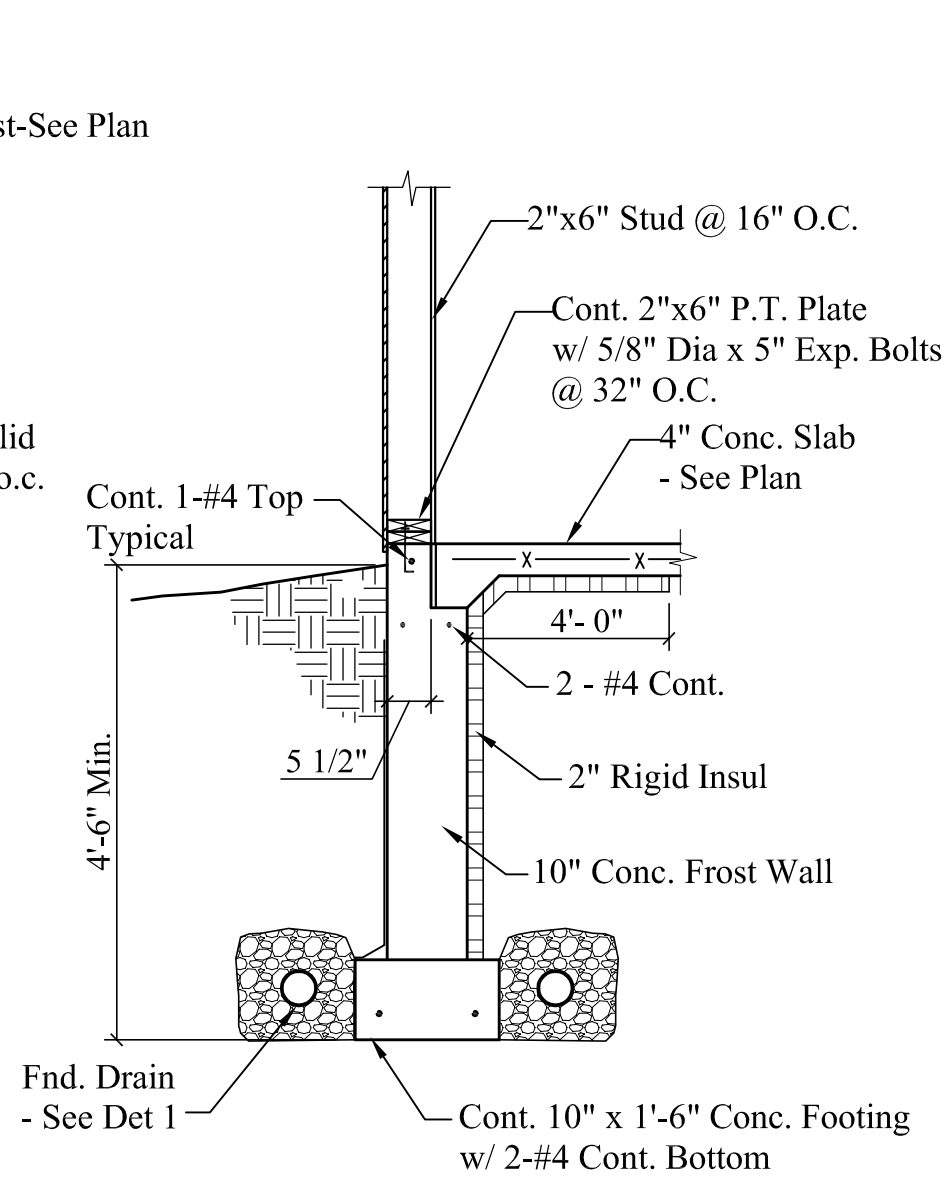

2 FOUNDATION @ STUD WALL
Scale: 1/2" = 1'-0"

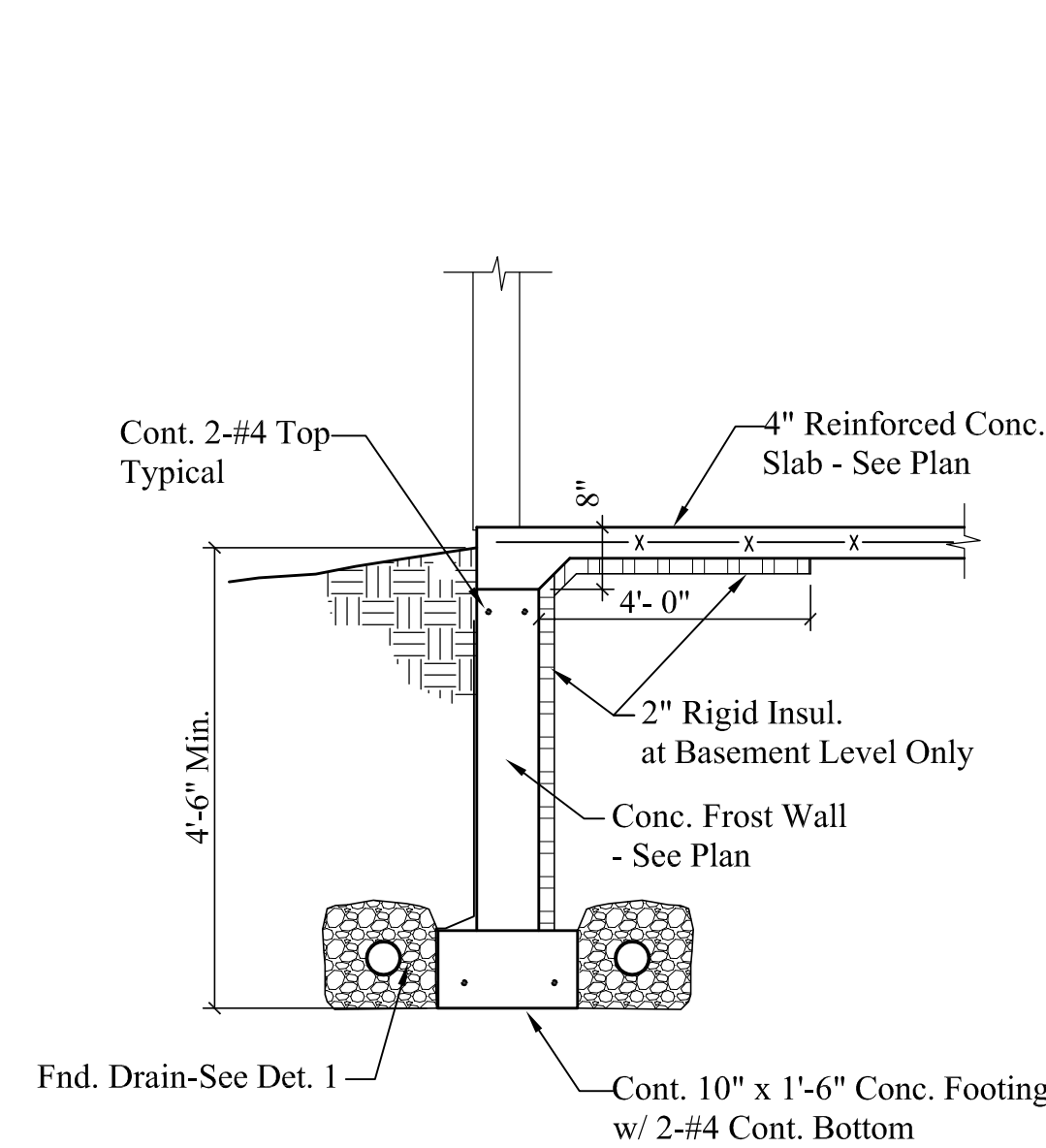

3 FROST WALL @ SLAB
Scale: 1/2" = 1'-0"

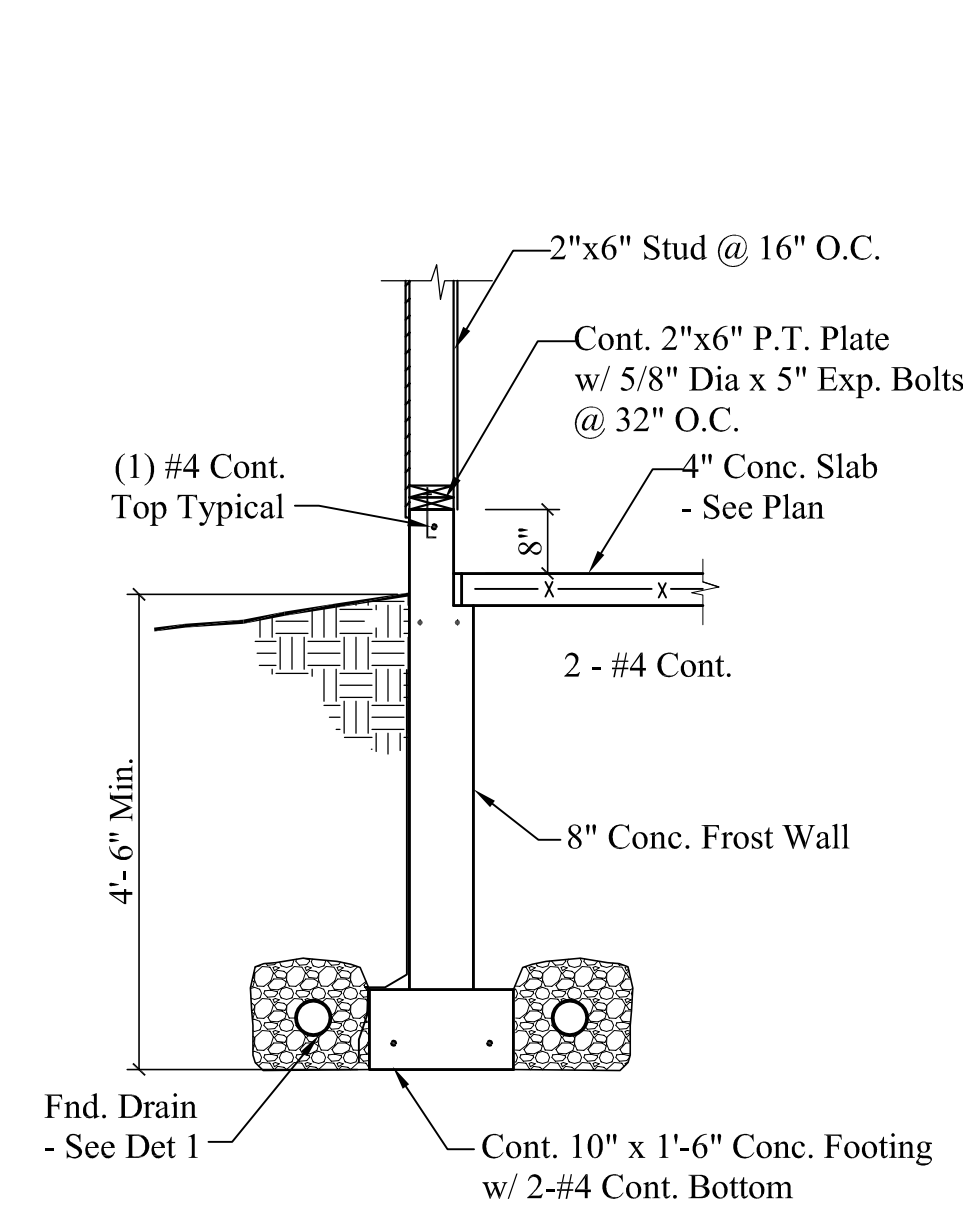

4 FROST WALL at GARAGE WALL
Scale: 1/2" = 1'-0"

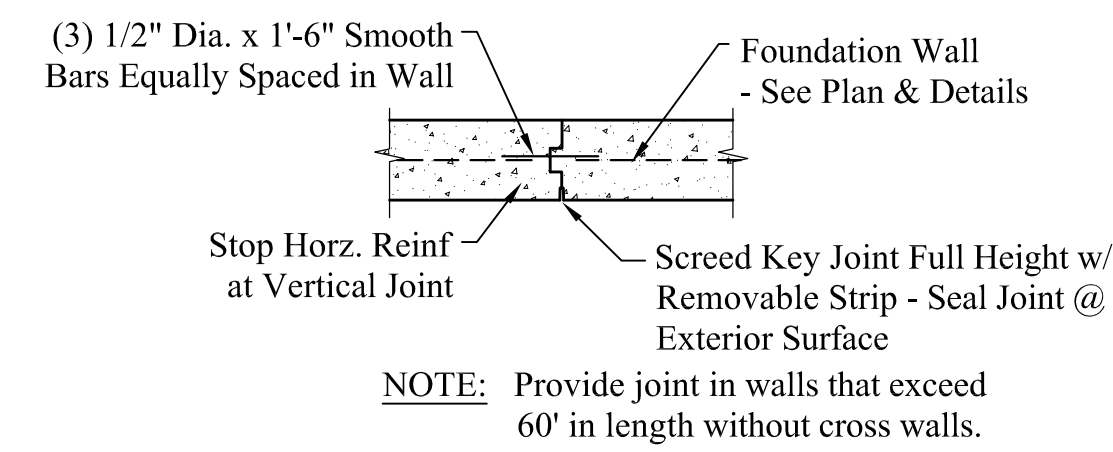

5 TYP. FLOOR & WALL JOINTS
Scale: 1/2" = 1'-0"

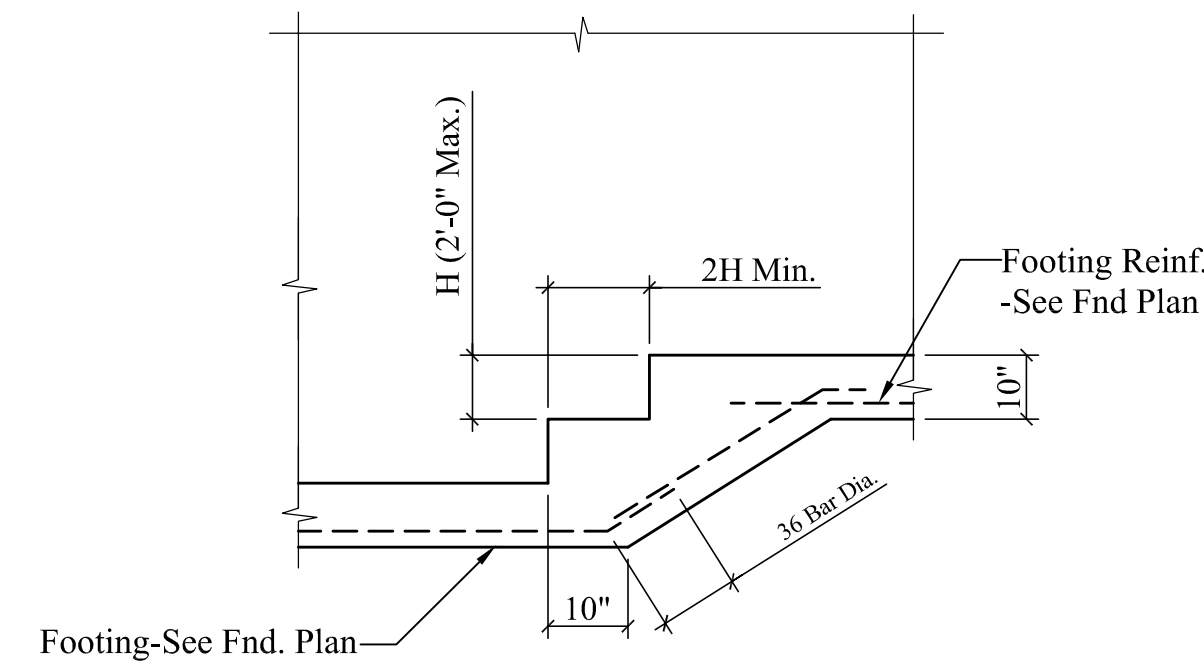

6 TYP STEP FOOTING DETAIL
Scale: 1/2" = 1'-0"

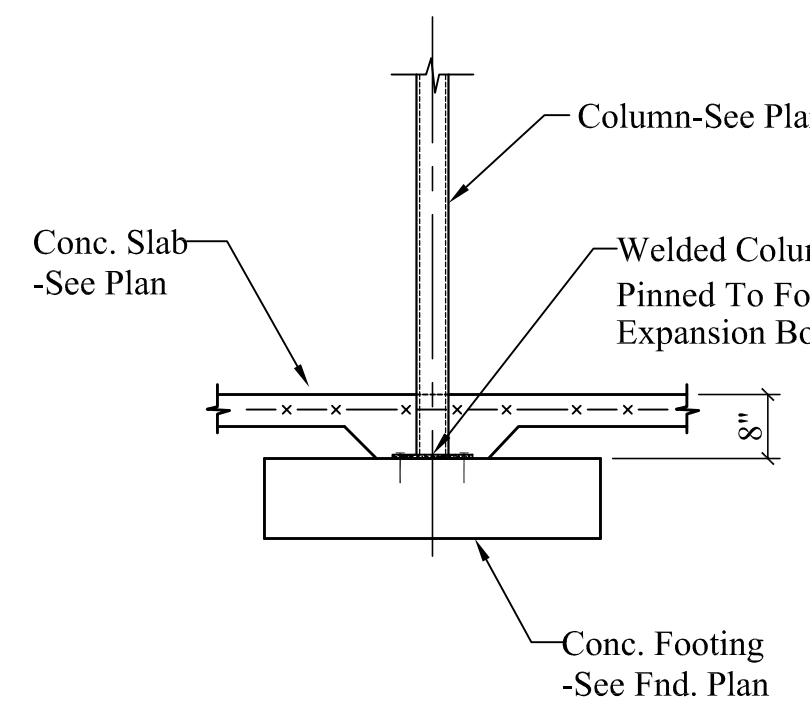

7 INTERIOR COLUMN FOOTING
Scale: 1/2" = 1'-0"

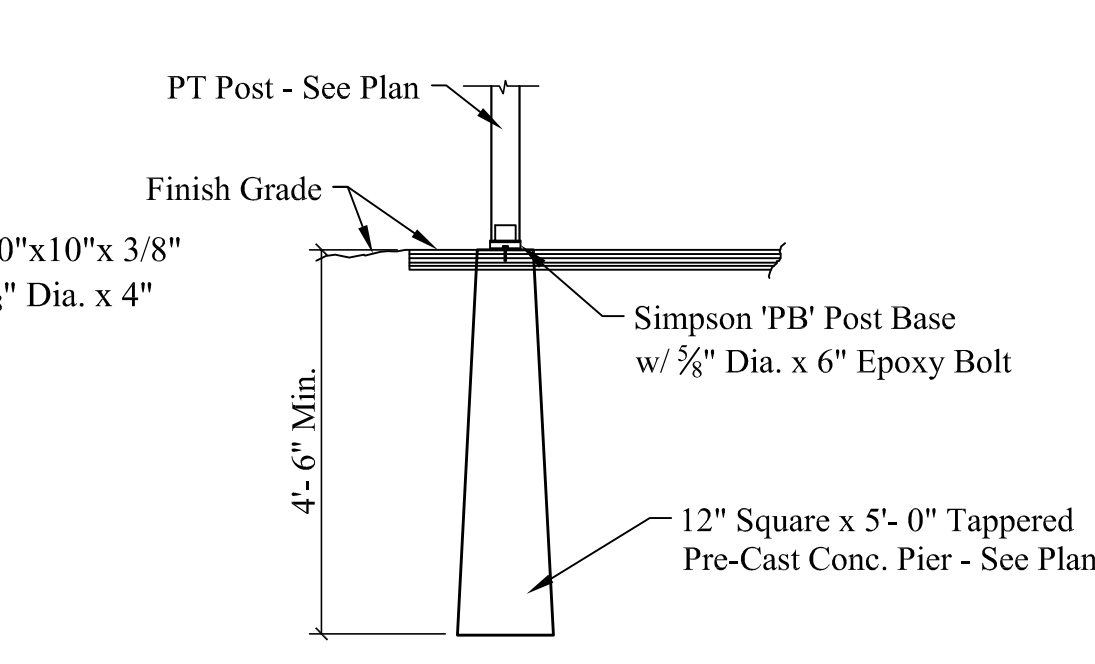

8 POST CONN. @ CONC. PIER
Scale: 1/2" = 1'-0"

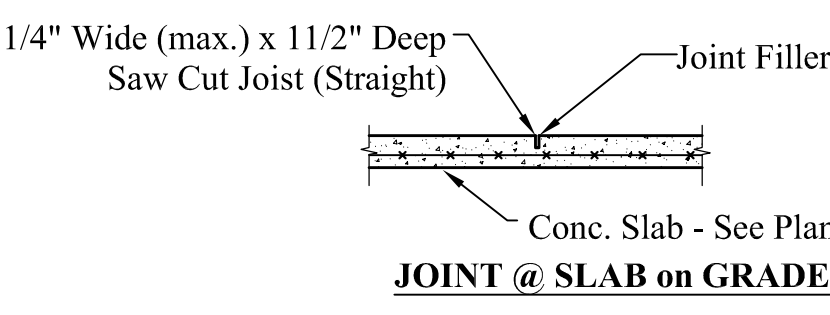

9 TYP. WALL & FTG REINF. @ CORNER
Scale: 1/2" = 1'-0"

STRUCTURAL NOTES:

CODE: Comply with the 2009 International Residential Code & MUBEC.

DESIGN LOADS:

Dead Loads: Roof = 15.0 psf, Floor = 10.0 psf.
Live Loads: Roof = 45.0 psf (Plus Drift), 1st Floor = 40.0 psf, 2nd Floor = 35.0 psf.
Wind Load: Building = 31.0 psf

FOUNDATIONS:

- Bear footings on firm, undisturbed dense native soil at 4"-0" minimum below lowest adjacent finish or natural grade, which ever is lower. Step footings to achieve these depths as required. If stone ledge is encountered place footing directly on ledge where exists.
- Assumed soil bearing pressure = 2,000 psf.
- Place foundation concrete only on clean, firm, dry bearing material. Dowel to stone ledge as detailed.
- Engineer shall be notified if stone ledge or marine clay is found during excavation.
- Place concrete slab over a 15 mil vapor barrier (taped and sealed at all joints) and locate over stone fill and drainage piping.
- Install 4" dia. perforated drain tile (rotate perforations to top of pipe) on exterior and interior of footing perimeter. Wrap all drain tile in filter fabric and encase with 3/4" crushed stone around entire pipe. Create a positive drain to atmosphere or dry well with drainage away from structure. Provide (2) stubs through slab for possible use in radon mitigation system. Contractor shall be responsible for any additional drainage requirements, such as sump pumps etc.
- All foundation wall exteriors shall be coated with damp proofing per manufacturer's spec. Damp proofing shall not be visible above final grade.
- See architectural drawings for additional information not shown.

CONCRETE:

- Concrete regular weight (144 pcf) with Type II cement per ASTM C150, aggregate per ASTM C33, and potable water. No fly-ash permitted in floor slab. Aggregate size = 1" maximum for footings and slab. Minimum compressive strength = 3000 psi for foundations and slab on grade and 4,000 psi for exterior slabs and sidewalks.
- Saw cuts for floor slab control joints (CJ) shall be made as soon as the slab can support the weight of the saw, but no more than 12 hours after placing concrete.
- Pitch all garage floor slabs 1/4" ft. toward over head door.

REINFORCING:

- ASTM A 615-S1, Grade 60 except #2 and #3 bars ASTM A615-S1: Grade 40.
- Lap splices in concrete: 42 bar diameters.
- Provide bent corner reinforcing to match and lap with horizontal reinforcing at corners and intersections of walls, and footings.
- Reinforcing shall be placed with 3" clearance at all surfaces.

STEEL:

- Rolled sections and plates: ASTM A-36, Fy = 36 ksi.
- Steel Lally Columns: ASTM A513, Fy = 32 ksi, 16 gage steel filled w/ 3,000 psi concrete.
- Steel Pipe Column: (not lally columns) ASTM A-36, Fy = 36 ksi.
- Bolts and plain anchors: ASTM A 307.
- Submit shop drawings. Fabricate after Engineers review.

WOOD:

- General:
 - Each piece of lumber shall be "S-DRY" and bear the grade stamp of a grading rules agency approved by the American Lumber Standards Committee.
 - Double up studs at jamb and under beams.
 - Do not notch or drill joists, beams or load bearing studs without approval.
- Connections:
 - Nail roof plywood with 8d common at 6" o.c. at all edges and boundary members and 10" o.c. at intermediate supports.
 - Glue floor plywood to all framing members and nail with 8d common at 6" o.c. at all plywood edges and boundary members and 10" o.c. at intermediate supports.
 - Nail CDX wall plywood with 10d common nails at 6" o.c. at all edges and boundary members and 12" o.c. at intermediate supports.
 - Nail Advantech R-6 wall sheathing with 0.131" Dia. x 3" common nails at 3" o.c. along all panel edges and 6" o.c. along intermediate supports.
- Structural Sawn Lumber:
 - 2 x 6 thru 2 x 14 joists: Spruce Pine Fir No. 2 with Fb (repetitive) = 1200 p.s.i.
 - Studs: Spruce Pine Fir No. 2 with Fb (repetitive) = 1200 p.s.i.
 - Laminated Veneer Lumber (LVL); Beams: Fb = 2,800 psi, Fv = 285 psi, E = 2,000 ksi; Posts: Fb = 2,400 psi, Fv = 190 psi, E = 1,800 ksi
- Plywood:
 - Roof Sheathing: C-D INT-APA (PSI-94) with exterior glue; 5/8" with Identification Index 48/24. Lay up with face grain perpendicular to supports. Stagger joints. Each plywood piece to be continuous over a minimum of two spans with a minimum width of 1'-0" unless blocking is provided at all joints.
 - Sub-flooring: C-D INT-APA (PSI-94) with exterior glue; 3/4" with Identification Index 48/24. Lay up with face grain perpendicular to supports. Stagger joints. Each plywood piece to be continuous over a minimum of two spans with a minimum width of 1'-0" unless blocking is provided at all joints.
 - Wall Sheathing: C-D INT-APA (PSI-74) with exterior glue; 1/2" CDX with Identification Index 24/0. All panel edges backed with 2" nominal or wider framing. Optional: Advantech R-6 Zip System, 7/16" OSB sheathing with 1" of foam. All panel edges backed with 2" nominal or wider framing.
- Light Metal Plate Connected Wood Trusses:
 - Design, fabricate, transport and erect per Truss Plate Institute Standards TPI-18 and BWT76.
 - Design for loads, in addition to member weights, as given under "DESIGN LOADS" above.
 - Submit design calculations and shop drawings. Fabricate after the Engineer's review. Include wood grades to be used.
 - All permanent and temporary bracing and fastening at bearings by truss manufacturer.
 - Comply with "SUPPLEMENTARY NOTES" below.
- Truss Joist Wood Trusses:
 - Design, fabricate and erect per ICC Evaluation Service Committee Report No. ESR-1153 for TJI joists.
 - Design, fabricate and erect per ICC Evaluation Service Committee Report No. ESR-1387 for TimberStrand LSL, MicroIam LVL & Parallam PSL members.
 - Design for loads, in addition to member weights, as given under "Design Loads" above.
 - Fire and sound ratings are to be established in accordance with assemblies as detailed in ICC ES ESR-1153 or the Directory of Listed Products, published by Intertek Testing Services.
 - TJI joists shall have "Flak Jacket" fire protection coating at first floor level or equivalent.
 - All "I" joists shall be manufactured with LVL flange material. Web material shall be equivalent to Performance Plus OSB.
 - Store product on site as recommended by product manufacturer.
 - Each of the joists shall be identified by a stamp indicating the joist series and ICC ES evaluation report number, manufacturer's name, plant number and the independent inspection agency's logo.
 - Submit product manufacturers "Specifier's Guide" for Engineer's review. Include wood grades to be used.
 - All permanent and temporary bracing and fastening at bearings by truss manufacturer.
 - Comply with "Supplementary Notes" below.

SUPPLEMENTARY NOTES:

- Verify all dimensions and conditions with architectural drawings prior to starting work. Notify the Engineer of any discrepancies or inconsistencies.
- Provide all necessary temporary bracing, shoring, guying or other means to avoid excessive stresses and to hold structural elements in place during construction.

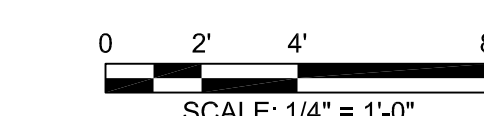

Mechanical, Electrical and Plumbing Design and Building Weatherization-Insulation-Ventilation by Others.

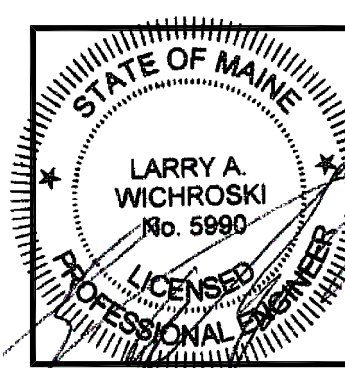
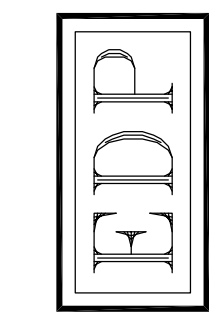

DESIGNED BY:	Larry A. Wichroski, P.E.
DRAWN BY:	LAW
JOB #:	04117
DATE:	10-18-2017

REVISIONS:	12-08-2017
------------	------------