



AquaSAFE™ FIRE SAFETY SYSTEM

Uponor
5925 148th Street West

Apple Valley, MN 55124
800-321-4739

A handwritten signature in blue ink, appearing to be "J. Grabarz", with a date "10-2" written below it.

Job Name : GRABARZ RESIDENCE - Two Head Calculation (H.22 & H.24)
Drawing : RESIDENTIAL
Location : 25 HAVERTYS WAY PORTLAND ME 04101
Remote Area : 1
Contract : 121109-42L
Data File : 121109-42L Grabaz Residence.wx2

HYDRAULIC DESIGN INFORMATION SHEET

Name - GRABARZ RESIDENCE Date - 11/15/12
Location - PORTLAND ME 04101
Building - RESIDENTIAL System No. - 1
Contractor - RSD PLUMB & HTG Contract No. - 121109-42L
Calculated By - BRENT KOTULA SET IV Drawing No. - 1
Construction: (X) Combustible () Non-Combustible Ceiling Height 8
OCCUPANCY - RESIDENTIAL

S Type of Calculation: ()NFPA 13 Residential ()NFPA 13R (X)NFPA 13D
Y Number of Sprinklers Flowing: ()1 (X)2 ()4 ()
S ()Other
T ()Specific Ruling Made by Date
E
M Listed Flow at Start Point - 13 Gpm System Type
Listed Pres. at Start Point - 9.14 Psi (X) Wet () Dry
D MAXIMUM LISTED SPACING 16 x 16 () Deluge () PreAction
E Domestic Flow Added - 0 Gpm Sprinkler or Nozzle
S Additional Flow Added - Gpm Make RELIABE-ASSEMBLIES Model AFC43
I Elevation at Highest Outlet - 117 Feet Size 3/8 K-Factor 4.3
G Note: Temperature Rating 165
N

Calculation Gpm Required 26.0983 Psi Required 50.17 At Ref Pt STR
Summary C-Factor Used: Overhead 150 Underground 150

W Water Flow Test: Pump Data: Tank or Reservoir:
A Date of Test - x Rated Cap. Cap.
T Time of Test - x @ Psi Elev.
E Static (Psi) - 52 Elev.
R Residual (Psi) - 47 Other Well
Flow (Gpm) - 300 Proof Flow Gpm
S Elevation - 91

P Location: STREET
P
L Source of Information: CONTRACTOR
Y

Water Supply Curve (C)

Uponsor
GRABARZ RESIDENCE - Two Head Calculation (H.22 & H.24)

City Water Supply:

C1 - Static Pressure : 52
C2 - Residual Pressure: 47
C2 - Residual Flow : 300

Demand:

D1 - Elevation : 11.261
D2 - System Flow : 26.0983
D2 - System Pressure : 50.166
Hose (Adj City) :
Hose (Demand) :
D3 - System Demand : 26.0983
Safety Margin : 1.779

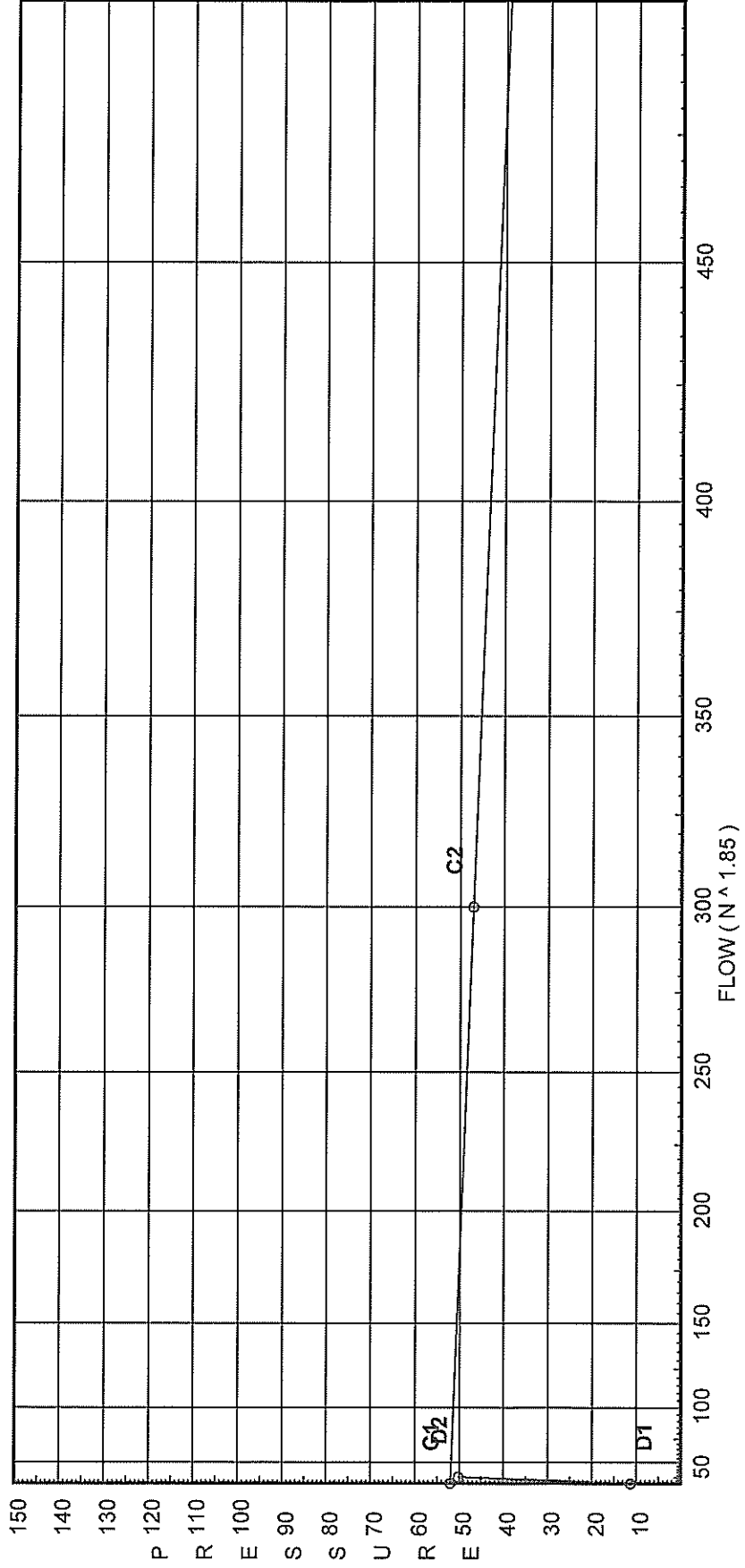

Fittings Used Summary

Uponsor GRABARZ RESIDENCE - Two Head Calculation (H.22 & H.24)

Page 3
Date 11/15/2012

Fitting Legend	Abbrev. Name	1/2	3/4	1	1 1/4	1 1/2	2	2 1/2	3	3 1/2	4	5	6	8	10	12	14	16	18	20	24
E	90' Standard Elbow	2	2	2	3	4	5	6	7	8	10	12	14	18	22	27	35	40	45	50	61
G	Generic Gate Valve	1	1	1	1	1	1	1	1	1	2	2	3	4	5	6	7	8	10	11	13
R	CPVC Coupling Tee - Run	1	1	1	1	1	1	2	2	0	0	0	0	0	0	0	0	0	0	0	0
T	90' Flow thru Tee	3	4	5	6	8	10	12	15	17	20	25	30	35	50	60	71	81	91	101	121
U	UnAdjusted Fitting	1	1	1	1	1	1	1	1	1	1	1	1	1	1	1	1	1	1	1	1
Utb	Aquaapex Tee - Branch	2	17	14	9	12	17	0	0	0	0	0	0	0	0	0	0	0	0	0	0
Utr	Aquaapex Tee - Run	1	2	2	4	2	1	0	0	0	0	0	0	0	0	0	0	0	0	0	0

Units Summary

Diameter Units Inches
 Length Units Feet
 Flow Units US Gallons per Minute
 Pressure Units Pounds per Square Inch

Flow Summary - NFPA 2007

Uponsor
GRABARZ RESIDENCE - Two Head Calculation (H.22 & H.24)

Page 4
Date 11/15/2012

SUPPLY ANALYSIS

<i>Node at Source</i>	<i>Static Pressure</i>	<i>Residual Pressure</i>	<i>Flow</i>	<i>Available Pressure</i>	<i>Total Demand</i>	<i>Required Pressure</i>
STR	52.0	47	300.0	51.945	26.1	50.166

NODE ANALYSIS

<i>Node Tag</i>	<i>Elevation</i>	<i>Node Type</i>	<i>Pressure at Node</i>	<i>Discharge at Node</i>	<i>Notes</i>
H.24	117.0	4.3	9.28	13.1	
H.22	117.0	4.3	9.14	13.0	
H.1	108.0		24.26		
H.2	108.0		24.29		
T.28	108.0		24.22		
H.3	108.0		24.18		
T.27	108.0		24.22		
M.31	108.0		24.27		
T.25	108.0		24.08		
H.4	108.0		24.26		
T.30	108.0		24.71		
H.5	108.0		24.29		
H.15	99.0		30.21		
H.6	108.0		24.38		
H.11	99.0		30.16		
H.8	108.0		24.45		
H.7	108.0		23.88		
T.33	99.0		30.54		
T.34	99.0		30.45		
T.35	99.0		30.46		
M.32	99.0		30.46		
H.10	99.0		30.37		
T.36	99.0		30.41		
T.37	99.0		30.37		
H.9	99.0		30.37		
H.12	117.0		16.43		
H.16	117.0		15.77		
H.14	117.0		15.42		
H.13	117.0		16.41		
H.17	99.0		30.28		
H.20	99.0		30.37		
T.38	117.0		15.57		
H.19	99.0		30.37		
H.18	117.0		19.49		
T.29	108.0		23.84		
M.41	117.0		19.71		
H.21	117.0		14.69		
H.23	117.0		13.24		
S.1	95.0		35.36		
MTR	91.0		45.12		
STR	91.0		50.17		

Final Calculations - Hazen-Williams

Uponor
GRABARZ RESIDENCE - Two Head Calculation (H.22 & H.24)

Page 5
Date 11/15/2012

Hyd. Ref. Point	Qa Qt	Dia. "C" Pf/Ft	Fitting or Eqv.	Ln.	Pipe Ftg's Total	Pt Pe Pf	Pt Pv Pn	*****	Notes	*****
H.24 to M.41	4.22	0.475 150.0	1T 21U	1.219 21.0	23.000 22.369	9.279 0.0			K Factor = 4.30	
	4.22	0.2298		0.0	45.369	10.427			Vel = 7.64	
	0.0 4.22					19.706			K Factor = 0.95	
H.22 to H.14	2.73	0.475 150.0	42U	42.0 0.0	19.000 42.300	9.140 0.0			K Factor = 4.30	
	2.73	0.1025		0.0	61.300	6.284			Vel = 4.94	
	0.0 2.73					15.424			K Factor = 0.70	
H.1 to H.2	0.15	0.475 150.0	42U	42.0 0.0	16.000 42.300	24.261 0.0				
	0.15	0.0005		0.0	58.300	0.029			Vel = 0.27	
	0.0 0.15					24.290			K Factor = 0.03	
T.28 to H.3	-0.23	0.475 150.0	1Utr 1R	1.0 1.0	11.000 23.150	24.215 0.0				
	-0.23	-0.0011	21U	21.0	34.150	-0.037			Vel = 0.42	
H.3 to T.26	0.53	0.475 150.0	1Utr 21U	1.0 21.0	3.000 23.150	24.178 0.0				
	0.3	0.0017	1R	1.0	26.150	0.045			Vel = 0.54	
	0.0 0.30					24.223			K Factor = 0.06	
T.27 to H.3	-0.29	0.475 150.0	1Utr 1R	1.0 1.0	5.000 23.150	24.225 0.0				
	-0.29	-0.0017	21U	21.0	28.150	-0.047			Vel = 0.53	
	0.0 -0.29					24.178			K Factor = -0.06	
M.31 to T.26	-0.30	0.475 150.0	1T 1R	1.219 1.0	25.000 2.219	24.269 0.0				
	-0.3	-0.0017		0.0	27.219	-0.046			Vel = 0.54	
	0.0 -0.30					24.223			K Factor = -0.06	
T.25 to H.1	0.46	0.475 150.0	1Utb 1R	2.0 1.0	22.000 24.150	24.084 0.0				
	0.46	0.0038	21U	21.0	46.150	0.177			Vel = 0.83	
	0.0 0.46					24.261			K Factor = 0.09	
M.31 to H.2	0.17	0.475 150.0	1T 21U	1.219 21.0	11.000 22.369	24.269 0.0				
	0.17	0.0006		0.0	33.369	0.021			Vel = 0.31	
	0.0 0.17					24.290			K Factor = 0.03	
H.3 to T.29	-0.82	0.475 150.0	1Utr 21U	1.0 21.0	7.000 23.150	24.178 0.0				
	-0.82	-0.0111	1R	1.0	30.150	-0.335			Vel = 1.48	
	0.0 -0.82					23.843			K Factor = -0.17	

Final Calculations - Hazen-Williams

Uponor
GRABARZ RESIDENCE - Two Head Calculation (H.22 & H.24)

Page 6
Date 11/15/2012

Hyd. Ref. Point	Qa Qt	Dia. "C" Pf/Ft	Fitting or Eqv.	Ln.	Pipe Ftng's Total	Pt Pe Pf	Pt Pv Pn	*****	Notes	*****
H.4 to T.28	-0.23 -0.23	0.475 150.0 -0.0011	21U 1R	21.0 1.0 0.0	22.000 22.150 44.150	24.262 0.0 -0.047			Vel = 0.42	
	0.0 -0.23					24.215			K Factor = -0.05	
H.4 to H.1	-0.02 -0.02	0.475 150.0 0.0	42U	42.0 0.0 0.0	12.000 42.300 54.300	24.262 0.0 -0.001			Vel = 0.04	
	0.0 -0.02					24.261			K Factor = 0	
T.30 to T.33	23.53 23.53	1.054 150.0 0.1136	1Utr	4.0 0.0 0.0	13.000 4.000 17.000	24.709 3.898 1.932			Vel = 8.65	
	0.0 23.53					30.539			K Factor = 4.26	
T.30 to M.31	-6.66 -6.66	0.862 150.0 -0.0293	1Utb	17.0 0.0 0.0	1.000 14.000 15.000	24.709 0.0 -0.440			Vel = 3.66	
	0.0 -6.66					24.269			K Factor = -1.35	
H.5 to H.2	0.03 0.03	0.475 150.0 0.0	42U	42.0 0.0 0.0	15.000 42.300 57.300	24.288 0.0 0.002			Vel = 0.05	
	0.0 0.03					24.290			K Factor = 0.01	
M.31 to H.4	-0.11 -0.11	0.475 150.0 -0.0003	1T 21U	1.219 21.0 0.0	5.000 22.369 27.369	24.269 0.0 -0.007			Vel = 0.20	
	0.0 -0.11					24.262			K Factor = -0.02	
T.27 to H.5	0.29 0.29	0.475 150.0 0.0017	1R 21U	1.0 21.0 0.0	16.000 22.150 38.150	24.225 0.0 0.063			Vel = 0.53	
	0.0 0.29					24.288			K Factor = 0.06	
H.4 to H.5	0.14 0.14	0.475 150.0 0.0004	42U	42.0 0.0 0.0	19.000 42.300 61.300	24.262 0.0 0.026			Vel = 0.25	
	0.0 0.14					24.288			K Factor = 0.03	
T.25 to H.7	-0.46 -0.46	0.475 150.0 -0.0038	1R 21U	1.0 21.0 0.0	30.000 22.150 52.150	24.084 0.0 -0.200			Vel = 0.83	
	0.0 -0.46					23.884			K Factor = -0.09	
H.15 to H.8	-1.21 -1.21	0.475 150.0 -0.0228	42U	42.0 0.0 0.0	39.000 42.300 81.300	30.209 -3.898 -1.857			Vel = 2.19	

Final Calculations - Hazen-Williams

Uponor
GRABARZ RESIDENCE - Two Head Calculation (H.22 & H.24)

Page 7
Date 11/15/2012

Hyd. Ref. Point	Qa Qt	Dia. "C" Pf/Ft	Fitting or Eqv.	Ln.	Pipe Ftng's Total	Pt Pe Pf	Pt Pv Pn	*****	Notes	*****
	0.0 -1.21					24.454			K Factor = -0.24	
M.31 to H.7	-0.62	0.475 150.0	1T 21U	1.219 21.0	36.000 22.369	24.269 0.0				Vel = 1.12
	-0.62	-0.0066		0.0	58.369	-0.385				
	0.0 -0.62					23.884			K Factor = -0.13	
H.6 to H.1	-0.29	0.475 150.0	42U	42.0 0.0	30.000 42.300	24.375 0.0				Vel = 0.53
	-0.29	-0.0016		0.0	72.300	-0.114				
	0.0 -0.29					24.261			K Factor = -0.06	
H.11 to H.6	-1.36	0.475 150.0	42U	42.0 0.0	25.000 42.300	30.165 -3.898				Vel = 2.46
	-1.36	-0.0281		0.0	67.300	-1.892				
	0.0 -1.36					24.375			K Factor = -0.28	
H.8 to H.2	-0.36	0.475 150.0	42U	42.0 0.0	27.000 42.300	24.454 0.0				Vel = 0.65
	-0.36	-0.0024		0.0	69.300	-0.164				
	0.0 -0.36					24.290			K Factor = -0.07	
H.6 to M.31	-0.39	0.475 150.0	21U 1T	21.0 1.219	16.000 22.369	24.375 0.0				Vel = 0.71
	-0.39	-0.0028		0.0	38.369	-0.106				
	0.0 -0.39					24.269			K Factor = -0.08	
H.8 to M.31	-0.45	0.475 150.0	21U 1T	21.0 1.219	29.000 22.369	24.454 0.0				Vel = 0.81
	-0.45	-0.0036		0.0	51.369	-0.185				
	0.0 -0.45					24.269			K Factor = -0.09	
H.8 to H.5	-0.41	0.475 150.0	42U	42.0 0.0	12.000 42.300	24.454 0.0				Vel = 0.74
	-0.41	-0.0031		0.0	54.300	-0.166				
	0.0 -0.41					24.288			K Factor = -0.08	
H.7 to H.6	0.68	0.475 150.0	42U	42.0 0.0	20.000 42.300	23.884 0.0				Vel = 1.23
	0.68	0.0079		0.0	62.300	0.491				
	0.0 0.68					24.375			K Factor = 0.14	
T.33 to S.1	26.10	1.054 150.0	1T	2.44 0.0	20.000 2.440	30.539 1.732				Vel = 9.60
	26.1	0.1377		0.0	22.440	3.090				
	0.0 26.10					35.361			K Factor = 4.39	

Final Calculations - Hazen-Williams

Uponor
GRABARZ RESIDENCE - Two Head Calculation (H.22 & H.24)

Page 8
Date 11/15/2012

Hyd. Ref. Point	Qa Qt	Dia. "C" Pf/Ft	Fitting or Eqv.	Ln.	Pipe Ftng's Total	Pt Pe Pf	Pt Pv Pn	*****	Notes	*****
T.33 to M.32	-2.57	0.862 150.0	1Utb	17.0 0.0	1.000 14.000	30.539 0.0				
	-2.57	-0.0050		0.0	15.000	-0.075			Vel = 1.41	
	0.0						30.464		K Factor = -0.47	
T.34 to M.32	0.42	0.475 150.0	1Utr 1R	1.0 1.0	1.000 3.219	30.450 0.0				
	0.42	0.0033	1T	1.219	4.219	0.014			Vel = 0.76	
	0.0						30.464		K Factor = 0.08	
T.34 to H.9	-0.42	0.475 150.0	1R 21U	1.0 21.0	2.000 22.150	30.450 0.0				
	-0.42	-0.0032		0.0	24.150	-0.077			Vel = 0.76	
	0.0						30.373		K Factor = -0.08	
T.35 to M.32	0.29	0.475 150.0	1Utr 1R	1.0 1.0	2.000 3.219	30.455 0.0				
	0.29	0.0017	1T	1.219	5.219	0.009			Vel = 0.53	
M.32 to H.10	-0.67	0.475 150.0	1T 21U	1.219 21.0	11.000 22.369	30.464 0.0				
	-0.38	-0.0027		0.0	33.369	-0.090			Vel = 0.69	
	0.0						30.374		K Factor = -0.07	
T.36 to M.32	0.60	0.475 150.0	1Utr 1R	1.0 1.0	5.000 3.219	30.413 0.0				
	0.6	0.0062	1T	1.219	8.219	0.051			Vel = 1.09	
	0.0						30.464		K Factor = 0.11	
T.37 to H.9	0.01	0.475 150.0	1Utr 1R	1.0 1.0	3.000 23.150	30.373 0.0				
	0.01	0.0	21U	21.0	26.150	0.0			Vel = 0.02	
	0.0						30.373		K Factor = 0	
H.11 to M.32	0.61	0.475 150.0	21U 1T	21.0 1.219	24.000 22.369	30.165 0.0				
	0.61	0.0064		0.0	46.369	0.299			Vel = 1.10	
	0.0						30.464		K Factor = 0.11	
H.9 to T.40	0.01	0.475 150.0	1Utr 21U	1.0 21.0	17.000 23.150	30.373 0.0				
	0.01	0.0	1R	1.0	40.150	0.0			Vel = 0.02	
	0.0						30.373		K Factor = 0	
H.9 to H.11	-0.42	0.475 150.0	42U	42.0 0.0	24.000 42.300	30.373 0.0				
	-0.42	-0.0031		0.0	66.300	-0.208			Vel = 0.76	
	0.0						30.165		K Factor = -0.08	

Final Calculations - Hazen-Williams

Uponsor
GRABARZ RESIDENCE - Two Head Calculation (H.22 & H.24)

Page 9
Date 11/15/2012

Hyd. Ref. Point	Qa Qt	Dia. "C" Pf/Ft	Fitting or Eqv.	Ln.	Pipe Ftnng's Total	Pt Pe Pf	Pt Pv Pn	*****	Notes	*****
H.15 to H.10	0.36	0.475 150.0	42U	42.0 0.0	24.000 42.300	30.209 0.0				
	0.36	0.0025		0.0	66.300	0.165			Vel = 0.65	
	0.0 0.36					30.374			K Factor = 0.07	
T.36 to H.15	-0.60	0.475 150.0	1R 21U	1.0 21.0	11.000 22.150	30.413 0.0				
	-0.6	-0.0062		0.0	33.150	-0.204			Vel = 1.09	
	0.0 -0.60					30.209			K Factor = -0.11	
H.12 to H.14	-1.05	0.475 150.0	42U	42.0 0.0	15.000 42.300	16.432 0.0				
	-1.05	-0.0176		0.0	57.300	-1.008			Vel = 1.90	
	0.0 -1.05					15.424			K Factor = -0.27	
H.16 to T.39	0.75	0.475 150.0	1Utr 21U	1.0 21.0	17.000 23.150	15.772 0.0				
	0.75	0.0093	1R	1.0	40.150	0.374			Vel = 1.36	
	0.0 0.75					16.146			K Factor = 0.19	
H.14 to T.38	0.51	0.475 150.0	1Utr 21U	1.0 21.0	9.000 23.150	15.424 0.0				
	0.51	0.0046	1R	1.0	32.150	0.149			Vel = 0.92	
	0.0 0.51					15.573			K Factor = 0.13	
H.13 to T.39	-0.75	0.475 150.0	21U 1R	21.0 1.0	6.000 22.150	16.407 0.0				
	-0.75	-0.0093		0.0	28.150	-0.261			Vel = 1.36	
	0.0 -0.75					16.146			K Factor = -0.19	
H.16 to H.12	0.88	0.475 150.0	42U	42.0 0.0	10.000 42.300	15.772 0.0				
	0.88	0.0126		0.0	52.300	0.660			Vel = 1.59	
	0.0 0.88					16.432			K Factor = 0.22	
H.13 to H.12	0.15	0.475 150.0	42U	42.0 0.0	11.000 42.300	16.407 0.0				
	0.15	0.0005		0.0	53.300	0.025			Vel = 0.27	
	0.0 0.15					16.432			K Factor = 0.04	
H.14 to H.13	1.17	0.475 150.0	42U	42.0 0.0	4.000 42.300	15.424 0.0				
	1.17	0.0212		0.0	46.300	0.983			Vel = 2.12	
	0.0 1.17					16.407			K Factor = 0.29	
H.17 to H.11	-0.33	0.475 150.0	42U	42.0 0.0	11.000 42.300	30.275 0.0				
	-0.33	-0.0021		0.0	53.300	-0.110			Vel = 0.60	

Final Calculations - Hazen-Williams

Uponor
GRABARZ RESIDENCE - Two Head Calculation (H.22 & H.24)

Page 10
Date 11/15/2012

Hyd. Ref. Point	Qa Qt	Dia. "C" Pf/Ft	Fitting or Eqv.	Ln.	Pipe Ftng's Total	Pt Pe Pf	Pt Pv Pn	*****	Notes	*****
	0.0 -0.33					30.165			K Factor = -0.06	
H.20 to H.10	0.01	0.475 150.0	42U	42.0 0.0	30.000 42.300	30.373 0.0			Vel = 0.02	
	0.0 0.01					30.374			K Factor = 0	
T.38 to H.16	0.51	0.475 150.0	1R 21U	1.0 21.0	21.000 22.150	15.573 0.0			Vel = 0.92	
	0.0 0.51					15.772			K Factor = 0.13	
H.17 to H.15	-0.25	0.475 150.0	42U	42.0 0.0	11.000 42.300	30.275 0.0			Vel = 0.45	
	0.0 -0.25					30.209			K Factor = -0.05	
M.32 to H.20	-0.27	0.475 150.0	1T 21U	1.219 21.0	41.000 22.369	30.464 0.0			Vel = 0.49	
	0.0 -0.27					30.373			K Factor = -0.05	
H.19 to T.35	0.29	0.475 150.0	21U 1R	21.0 1.0	28.000 22.150	30.374 0.0			Vel = 0.53	
	0.0 0.29					30.455			K Factor = 0.05	
H.19 to H.10	0.0	0.475 150.0	42U	42.0 0.0	37.000 42.300	30.374 0.0			Vel = 0	
	0.0 0.0					30.374			K Factor = 0	
H.18 to H.12	-2.08	0.475 150.0	42U	42.0 0.0	7.000 42.300	19.487 0.0			Vel = 3.77	
	0.0 -2.08					16.432			K Factor = -0.51	
H.7 to H.13	-1.76	0.475 150.0	42U	42.0 0.0	36.000 42.300	23.884 -3.898			Vel = 3.19	
	0.0 -1.76					16.407			K Factor = -0.43	
T.37 to H.20	-0.01	0.475 150.0	1R 21U	1.0 21.0	38.000 22.150	30.373 0.0			Vel = 0.02	
	0.0 -0.01					30.373			K Factor = 0	

Final Calculations - Hazen-Williams

Uponsor
GRABARZ RESIDENCE - Two Head Calculation (H.22 & H.24)

Page 11
Date 11/15/2012

Hyd. Ref. Point	Qa Qt	Dia. "C" Pf/Ft	Fitting or Eqv.	Ln.	Pipe Ftng's Total	Pt Pe Pf	Pt Pv Pn	*****	Notes	*****
T.29 to H.18	-0.82 -0.82	0.475 150.0 -0.0111	1R 21U	1.0 21.0 0.0	19.000 22.150 41.150	23.843 -3.898 -0.458			Vel = 1.48	
	0.0 -0.82						19.487		K Factor = -0.19	
M.41 to H.18	0.63 0.63	0.475 150.0 -0.0068	1T 21U	1.219 21.0 0.0	10.000 22.369 32.369	19.706 0.0 -0.219			Vel = 1.14	
H.18 to M.41	-1.26 -0.63	0.475 150.0 0.0068	1T 21U	1.219 21.0 0.0	10.000 22.369 32.369	19.487 0.0 0.219			Vel = 1.14	
	0.0 -0.63						19.706		K Factor = -0.14	
H.19 to T.40	-0.01 -0.01	0.475 150.0 0.0	21U 1R	21.0 1.0 0.0	19.000 22.150 41.150	30.374 0.0 -0.001			Vel = 0.02	
	0.0 -0.01						30.373		K Factor = 0	
M.41 to T.30	16.86 16.86	1.054 150.0 0.0614		0.0 0.0 0.0	18.000 0.0 18.000	19.706 3.898 1.105			Vel = 6.20	
	0.0 16.86						24.709		K Factor = 3.39	
H.16 to H.21	-1.11 -1.11	0.475 150.0 -0.0195	42U	42.0 0.0 0.0	13.000 42.300 55.300	15.772 0.0 -1.079			Vel = 2.01	
	0.0 -1.11						14.693		K Factor = -0.29	
H.17 to H.20	0.29 0.29	0.475 150.0 0.0017	42U	42.0 0.0 0.0	17.000 42.300 59.300	30.275 0.0 0.098			Vel = 0.53	
	0.0 0.29						30.373		K Factor = 0.05	
H.19 to H.17	-0.29 -0.29	0.475 150.0 -0.0016	42U	42.0 0.0 0.0	20.000 42.300 62.300	30.374 0.0 -0.099			Vel = 0.53	
	0.0 -0.29						30.275		K Factor = -0.05	
M.41 to H.22	3.98 3.98	0.475 150.0 -0.2057	1T 21U	1.219 21.0 0.0	29.000 22.369 51.369	19.706 0.0 -10.566			Vel = 7.21	
H.22 to M.41	-7.96 -3.98	0.475 150.0 0.2057	1T 21U	1.219 21.0 0.0	29.000 22.369 51.369	9.140 0.0 10.566			Vel = 7.21	
	0.0 -3.98						19.706		K Factor = -0.90	
H.21 to M.31	2.94 2.94	0.475 150.0 0.1174	21U 1T	21.0 1.219 0.0	26.000 22.369 48.369	14.693 3.898 5.678			Vel = 5.32	

Final Calculations - Hazen-Williams

Uponor
GRABARZ RESIDENCE - Two Head Calculation (H.22 & H.24)

Page 12
Date 11/15/2012

Hyd. Ref. Point	Qa Qt	Dia. "C" Pf/Ft	Fitting or Eqv.	Ln.	Pipe Ftng's Total	Pt Pe Pf	Pt Pv Pn	*****	Notes	*****
	0.0 2.94						24.269		K Factor = 0.60	
H.23 to M.41	3.43	0.475 150.0	21U 1T	21.0 1.219	19.000 22.369	13.241 0.0				
	3.43	0.1563		0.0	41.369	6.465			Vel = 6.21	
	0.0 3.43						19.706		K Factor = 0.77	
H.21 to H.23	-1.36	0.475 150.0	42U	42.0 0.0	9.000 42.300	14.693 0.0				
	-1.36	-0.0283		0.0	51.300	-1.452			Vel = 2.46	
	0.0 -1.36						13.241		K Factor = -0.37	
H.22 to H.23	2.31	0.475 150.0	42U	42.0 0.0	12.000 42.300	9.140 0.0				
	2.31	0.0755		0.0	54.300	4.101			Vel = 4.18	
	0.0 2.31						13.241		K Factor = 0.63	
H.24 to H.21	2.69	0.475 150.0	42U	42.0 0.0	12.000 42.300	9.279 0.0				
	2.69	0.0997		0.0	54.300	5.414			Vel = 4.87	
	0.0 2.69						14.693		K Factor = 0.70	
H.24 to H.23	2.48	0.475 150.0	42U	42.0 0.0	4.000 42.300	9.279 0.0				
	2.48	0.0856		0.0	46.300	3.962			Vel = 4.49	
	0.0 2.48						13.241		K Factor = 0.68	
M.31 to H.24	-3.71	0.475 150.0	1T 21U	1.219 21.0	39.000 22.369	24.269 -3.898				
	-3.71	-0.1807		0.0	61.369	-11.092			Vel = 6.72	
	0.0 -3.71						9.279		K Factor = -1.22	
S.1 to MTR	26.10	1.054 150.0	2E	2.44 0.0	5.000 2.440	35.361 8.732			* Fixed loss = 7	
	26.1	0.1378		0.0	7.440	1.025			Vel = 9.60	
MTR to STR	0.0	1.314 150.0	1E 1T	2.247 4.495	100.000 7.304	45.118 0.0				
	26.1	0.0470	1G	0.562	107.304	5.048			Vel = 6.18	
	0.0 26.10						50.166		K Factor = 3.68	



June 6, 2012

Dear Professional Partner:

We are pleased to announce that the vast majority of our engineered polymer (EP) fittings as well as our larger-diameter Uponor AquaPEX® (up to 2") are now listed to UL 1821 and ULC/ORD-C199P for use in AquaSAFE™ Residential Fire Sprinkler Systems.

This listing allows even more efficiency and alternatives in AquaSAFE™ designs, providing the most comprehensive offering of both EP fittings and larger-dimension PEX for multipurpose residential fire sprinkler systems.

The following table offers an overview of all the Uponor products now listed to UL 1821 and ULC/ORD-C199P. For a comprehensive list of part numbers and part descriptions, refer to the following two pages.

Item	1/2"	3/4"	1"	1 1/4"	1 1/2"	2"
Uponor AquaPEX Tubing, White	X	X	X	X	X	X
ProPEX Rings	X	X	X	X	X	X
EP Couplings	X	X	X	X	X	X
EP Elbows	X	X	X	X	X	X
EP Tees	X	X	X	X	X	X
EP Reducing Tees	X	X	X	X	X	X
EP Plugs	X	X	X	X	X	X
Male Adapters	N/A	X	X	X	X	X
Female Adapters	N/A	X	X	X	X	X
Sweat Adapters	N/A	X	X	X	X	X

X = Existing listing
X = New listing

If you have further questions, please feel free to contact me at 800.321.4739, ext. 5387 or jayson.drake@uponor.com.

Best regards,

Jayson Drake
Director of Plumbing and Fire Safety

Uponor North America

Uponor, Inc.
5925 148th Street West
Apple Valley, MN 55124
Tel: (800) 321-4739
Fax: (952) 891-2008
Web: www.uponor-usa.com

Uponor Ltd.
2000 Argenta Road
Plaza 1, Suite 200
Mississauga, ON L5N 1W1
Tel: (888) 994-7726
Fax: (800) 638-9517
Web: www.uponor.ca



The following items are now listed to UL 1821 and ULC/ORD-C199P for use in Uponor AquaSAFE™ residential fire protection systems. For additional product and pricing information, refer to the Uponor Product Catalog online at www.uponorpro.com.

Part No.	Part Description
Tubing	
Multiple	1¼" Uponor AquaPEX White
Multiple	1½" Uponor AquaPEX White
Multiple	2" Uponor AquaPEX White
ProPEX Rings	
Q4691250	1¼" ProPEX Ring
Q4691500	1½" ProPEX Ring
Q4682000	2" ProPEX Ring
Couplings	
Q4775050	ProPEX EP Coupling, 1/2" PEX x 1/2" PEX
Q4775075	ProPEX EP Coupling, 1/2" PEX x 3/4" PEX
Q4777510	ProPEX EP Coupling, 3/4" PEX x 1" PEX
Q4777575	ProPEX EP Coupling, 3/4" PEX x 3/4" PEX
Q4771010	ProPEX EP Coupling, 1" PEX x 1" PEX
Q4771307	ProPEX EP Coupling, 1-1/4" PEX x 3/4" PEX
Q4771310	ProPEX EP Coupling, 1-1/4" PEX x 1" PEX
Q4771313	ProPEX EP Coupling, 1-1/4" PEX x 1-1/4" PEX
Q4771507	ProPEX EP Coupling, 1-1/2" PEX x 3/4" PEX
Q4771510	ProPEX EP Coupling, 1-1/2" PEX x 1" PEX
Q4771513	ProPEX EP Coupling, 1-1/2" PEX x 1-1/2" PEX
Q4771515	ProPEX EP Coupling, 1-1/2" PEX x 1-1/4" PEX
Q4772015	ProPEX EP Coupling, 2" PEX x 1-1/2" PEX
Q4772020	ProPEX EP Coupling, 2" PEX x 2" PEX
Elbows	
Q4760500	ProPEX EP Elbow, 1/2" PEX x 1/2" PEX
Q4760750	ProPEX EP Elbow, 3/4" PEX x 3/4" PEX
Q4761000	ProPEX EP Elbow, 1" PEX x 1" PEX
Q4761250	ProPEX EP Elbow, 1-1/4" PEX x 1-1/4" PEX
Q4761500	ProPEX EP Elbow, 1-1/2" PEX x 1-1/2" PEX
Q4762000	ProPEX EP Elbow, 2" PEX x 2" PEX
Tees	
Q4755050	ProPEX EP Tee, 1/2" PEX x 1/2" PEX x 1/2" PEX
Q4757575	ProPEX EP Tee, 3/4" PEX x 3/4" PEX x 3/4" PEX
Q4751010	ProPEX EP Tee, 1" PEX x 1" PEX x 1" PEX
Q4751313	ProPEX EP Tee, 1-1/4" PEX x 1-1/4" PEX x 1-1/4" PEX
Q4751515	ProPEX EP Tee, 1-1/2" PEX x 1-1/2" PEX x 1-1/2" PEX
Q4752000	ProPEX EP Tee, 2" PEX x 2" PEX x 2" PEX

Uponor North America

Uponor, Inc.
5925 148th Street West
Apple Valley, MN 55124
Tel: (800) 321-4739
Fax: (952) 891-2008
Web: www.uponor-usa.com

Uponor Ltd.
2000 Argentia Road
Plaza 1, Suite 200
Mississauga, ON L5N 1W1
Tel: (888) 994-7726
Fax: (800) 638-9517
Web: www.uponor.ca



Reducing Tees	
Q4755575	ProPEX EP Reducing Tee, 1/2" PEX x 1/2" PEX x 3/4" PEX
Q4757550	ProPEX EP Reducing Tee, 3/4" PEX x 3/4" PEX x 1/2" PEX
Q4757555	ProPEX EP Reducing Tee, 3/4" PEX x 1/2" PEX x 1/2" PEX
Q4757557	ProPEX EP Reducing Tee, 3/4" PEX x 1/2" PEX x 3/4" PEX
Q4757710	ProPEX EP Reducing Tee, 3/4" PEX x 3/4" PEX x 1" PEX
Q4751150	ProPEX EP Reducing Tee, 1" PEX x 1" PEX x 1/2" PEX
Q4751175	ProPEX EP Reducing Tee, 1" PEX x 1" PEX x 3/4" PEX
Q4751311	ProPEX EP Reducing Tee, 1-1/4" PEX x 1" PEX x 3/4" PEX
Q4751317	ProPEX EP Reducing Tee, 1-1/4" PEX x 1" PEX x 1" PEX
Q4751331	ProPEX EP Reducing Tee, 1-1/4" PEX x 1-1/4" PEX x 1" PEX
Q4751337	ProPEX EP Reducing Tee, 1-1/4" PEX x 1-1/4" PEX x 3/4" PEX
Q4751511	ProPEX EP Reducing Tee, 1-1/2" PEX x 1" PEX x 1" PEX
Q4751517	ProPEX EP Reducing Tee, 1-1/2" PEX x 1" PEX x 3/4" PEX
Q4751531	ProPEX EP Reducing Tee, 1-1/2" PEX x 1-1/4" PEX x 1" PEX
Q4751533	ProPEX EP Reducing Tee, 1-1/2" PEX x 1-1/4" PEX x 1-1/4" PEX
Q4751537	ProPEX EP Reducing Tee, 1-1/2" PEX x 1-1/4" PEX x 3/4" PEX
Q4751551	ProPEX EP Reducing Tee, 1-1/2" PEX x 1-1/2" PEX x 3/4" PEX
Q4751553	ProPEX EP Reducing Tee, 1-1/2" PEX x 1-1/2" PEX x 1-1/4" PEX
Q4751557	ProPEX EP Reducing Tee, 1-1/2" PEX x 1-1/2" PEX x 1" PEX
Q4751751	ProPEX EP Reducing Tee, 1" PEX x 3/4" PEX x 1" PEX
Q4751775	ProPEX EP Reducing Tee, 1" PEX x 3/4" PEX x 3/4" PEX
Q4752051	ProPEX EP Reducing Tee, 2" PEX x 1-1/2" PEX x 1" PEX
Q4752053	ProPEX EP Reducing Tee, 2" PEX x 1-1/2" PEX x 1-1/4" PEX
Q4752055	ProPEX EP Reducing Tee, 2" PEX x 1-1/2" PEX x 1-1/2" PEX
Q4752210	ProPEX EP Reducing Tee, 2" PEX x 2" PEX x 1" PEX
Q4752213	ProPEX EP Reducing Tee, 2" PEX x 2" PEX x 1-1/4" PEX
Q4752215	ProPEX EP Reducing Tee, 2" PEX x 2" PEX x 1-1/2" PEX
Q4752275	ProPEX EP Reducing Tee, 2" PEX x 2" PEX x 3/4" PEX
Q4752575	ProPEX EP Reducing Tee, 2" PEX x 1-1/2" PEX x 3/4" PEX
Plugs	
Q4350500	ProPEX EP Plug, 1/2" PEX
Q4350750	ProPEX EP Plug, 3/4" PEX
Q4351000	ProPEX EP Plug, 1" PEX
Q4351250	ProPEX EP Plug, 1-1/4" PEX
Q4351500	ProPEX EP Plug, 1-1/2" PEX
Q4352000	ProPEX EP Plug, 2" PEX
Male Adapters	
LF4521313	ProPEX LF Brass Male Threaded Adapter, 1-1/4" PEX x 1-1/4" NPT
LF4521515	ProPEX LF Brass Male Threaded Adapter, 1-1/2" PEX x 1-1/2" NPT
LF4522020	ProPEX LF Brass Male Threaded Adapter, 2" PEX x 2" NPT
Female Adapters	
LF4571313	ProPEX LF Brass Female Threaded Adapter, 1-1/4" PEX x 1-1/4" NPT
LF4571515	ProPEX LF Brass Female Threaded Adapter, 1-1/2" PEX x 1-1/2" NPT
LF4572020	ProPEX LF Brass Female Threaded Adapter, 2" PEX x 2" NPT
Sweat Adapters	
LF4511313	ProPEX LF Brass Sweat Adapter, 1-1/4" PEX x 1-1/4" Copper
LF4511515	ProPEX LF Brass Sweat Adapter, 1-1/2" PEX x 1-1/2" Copper
LF4512020	ProPEX LF Brass Sweat Adapter, 2" PEX x 2" Copper

Uponor North America

Uponor, Inc.

5925 148th Street West
Apple Valley, MN 55124
Tel: (800) 321-4739
Fax: (952) 891-2008
Web: www.uponor-usa.com

Uponor Ltd.

2000 Argentia Road
Plaza 1, Suite 200
Mississauga, ON L5N 1W1
Tel: (888) 994-7726
Fax: (800) 638-9517
Web: www.uponor.ca

Uponor AquaPEX® White

Submittal Information
Revision D: July 6, 2010

Project Information

Job Name:

Location:

Part No. Ordered:

Engineer:

Date Submitted:

Contractor:

Submitted By:

Manufacturer's Representative:

Approved By:

Technical Data

Material:	Crosslinked polyethylene PEX-a Engel Method; PEX 5006
Standard Grade Hydrostatic Ratings (PPI):	200°F (93°C) at 80 psi 180°F (82°C) at 100 psi 73.4°F (23°C) at 160 psi ½", ¾", and 1" AquaPEX® White only: 120°F (49°C) at 130 psi
Linear Expansion Rate:	1.1"/10°F (12°C)/100'



Product Information and Application Use

Uponor AquaPEX White is tubing used for hot and cold domestic potable water distribution, residential fire safety and radiant heating systems containing no ferrous corrodible components or where ferrous components are isolated from the tubing.

✓	Description	Part Number	I.D. (A)	O.D. (B)	Weight
<input type="checkbox"/>	¼" Uponor AquaPEX White, 100-ft. coil	F1040250	0.241"	0.375"	4.0 lbs.
<input type="checkbox"/>	¾" Uponor AquaPEX White, 400-ft. coil	F1090375	0.350"	0.500"	20.0 lbs.
<input type="checkbox"/>	¾" Uponor AquaPEX White, 1,000-ft. coil	F1120375	0.350"	0.500"	44.0 lbs.
<input type="checkbox"/>	½" Uponor AquaPEX White, 100-ft. coil*	F1040500	0.475"	0.625"	6.0 lbs.
<input type="checkbox"/>	½" Uponor AquaPEX White, 300-ft. coil*	F1060500	0.475"	0.625"	18.0 lbs.
<input type="checkbox"/>	½" Uponor AquaPEX White, 1,000-ft. coil*	F1120500	0.475"	0.625"	54.0 lbs.
<input type="checkbox"/>	⅝" Uponor AquaPEX White, 300-ft. coil	F1060625	0.574"	0.750"	28.0 lbs.
<input type="checkbox"/>	⅝" Uponor AquaPEX White, 1000-ft. coil	F1120625	0.574"	0.750"	86.0 lbs.
<input type="checkbox"/>	¾" Uponor AquaPEX White, 100-ft. coil*	F1040750	0.671"	0.875"	10.0 lbs.
<input type="checkbox"/>	¾" Uponor AquaPEX White, 300-ft. coil*	F1060750	0.671"	0.875"	34.0 lbs.
<input type="checkbox"/>	¾" Uponor AquaPEX White, 500-ft. coil*	F1100750	0.671"	0.875"	54.0 lbs.
<input type="checkbox"/>	1" Uponor AquaPEX White, 100-ft. coil*	F1041000	0.862"	1.125"	20.0 lbs.
<input type="checkbox"/>	1" Uponor AquaPEX White, 300-ft. coil*	F1061000	0.862"	1.125"	56.0 lbs.
<input type="checkbox"/>	1" Uponor AquaPEX White, 500-ft. coil*	F1101000	0.862"	1.125"	93.0 lbs.
<input type="checkbox"/>	1¼" Uponor AquaPEX White, 100-ft. coil	F1061250	1.054"	1.375"	34.0 lbs.
<input type="checkbox"/>	1¼" Uponor AquaPEX White, 300-ft. coil	F1021250	1.054"	1.375"	106.0 lbs.
<input type="checkbox"/>	1½" Uponor AquaPEX White, 100-ft. coil	F1061500	1.244"	1.625"	44.0 lbs.
<input type="checkbox"/>	1½" Uponor AquaPEX White, 300-ft. coil	F1021500	1.244"	1.625"	133.0 lbs.
<input type="checkbox"/>	2" Uponor AquaPEX White, 100-ft. coil	F1062000	1.629"	2.125"	68.2 lbs.
<input type="checkbox"/>	2" Uponor AquaPEX White, 200-ft. coil	F1052000	1.629"	2.125"	136.4 lbs.
<input type="checkbox"/>	2" Uponor AquaPEX White, 300-ft. coil	F1022000	1.629"	2.125"	204.6 lbs.
<input type="checkbox"/>	3" Uponor AquaPEX White, 100-ft. coil	F1063000	2.400"	3.125"	128.0 lbs.
<input type="checkbox"/>	3" Uponor AquaPEX White, 350-ft. coil	F1023000	2.400"	3.125"	442.0 lbs.

Installation

Approved fittings are ProPEX® fittings¹ for sizes ¾" through 2" AquaPEX. Use WIPEX™ fittings for 3" AquaPEX. Refer to the Uponor Professional Plumbing Installation Guide, Radiant Floor Heating Installation Handbook or AquaSAFE™ Residential Fire Sprinkler Installation Guide for more information.

Standards	Codes	Listings
CSA B137.5; ASTM F876; ASTM F877; ASTM F1960; ASTM-E84; ASTM-E119/UL 263	IPC; UPC; NSPC; NPC of Canada	*½", ¾", 1" UL 1821; *ULC/ORD - C 199 P; IAPMO; CSA; HUD; WARNOCK HERSEY; NSF; ITS; UL; ICC; ANSI/NSF 14- and 61-certified; AWWA C904 ² ; CAN/ULC S102.2 (U.S.: ¾" diameter and smaller; Canada: 1" diameter and smaller)

Related Applications





PEX-a Plumbing Systems
Radiant Heating and Cooling Systems
AquaSAFE Fire Safety Systems

Contact Information

Uponor, Inc.
5925 148th Street West
Apple Valley, MN 55124 USA
Phone: (800) 321-4739
Fax: (952) 891-2008
www.uponor-usa.com

Uponor Ltd.
2000 Argentinia Rd., Plaza 1, Ste. 200
Mississauga, ON L5N 1W1 CANADA
Phone: (888) 994-7726
Fax: (800) 638-9517
www.uponor.ca

¹ProPEX® is a registered trademark of Uponor, Inc. ProPEX™ is a trademark of Uponor Ltd.
²This listing is for ¾" AquaPEX tubing and larger.

Print Stream on Tubing	Explanation
UPONOR AquaPEX	Brand Name
PEX 5006	ASTM F2023 Testing I/A/W ASTM F876
½ IN	Tubing Size (Example: ½")
SDR9	Standard Dimensional Ratio of 9
 B137.5 POTABLE	Potable Water Listing by CSA
 130PSI 120° F (49° C) UL1821	Rating I/A/W UL 1821 (½", ¾" and 1" only)
ULC-ORD C199P ¹	Canadian Rating I/A/W UL1821 and C199P
 ASTM F876/F877/F2023	ASTM Tubing Standards Listed by NSF
ASTM F1960/F2080/F1807	ASTM Fitting Standards Listed by NSF
	IAPMO Reports 3558, 3960
ICC ESR-1099	ICC Evaluation Services Report ESR-1099
ICC ESR1529	ICC Evaluation Services Report ESR 1529
HUD MR1269d	HUD Material Release Report 1269d
WHI-LISTED CAN/US FS25/SD50	Warnock-Hersey Listing for 25/50 Plenum Rating
160PSI 73.4°F (23°C)/100PSI 180°F (82°C)/80PSI 200°F (93°C)	Hydrostatic Ratings from PPI in Accordance with ASTM F876
UPONOR PEX-a TUBING	Type of Crosslinking (PEX-a)
UN04950127 ²	Manufacturing Code to Audit Material Source
xxxxxx ³	Footage Marker in Increments of 3' (three feet)

¹ For ½-inch tubing only

² USA, Material Type, Extruder No., Year, Month, Day

³ Footage marking in increments of three feet (3')

Table 1-1: Print Stream Identification

ProPEX® Sprinkler Adapters and Fittings

Uponor offers sprinkler adapter fittings specifically designed for the AquaSAFE Fire Safety system. These fittings feature ProPEX connections and a standard ½" NPT outlet for connecting fire sprinklers.

Table 1-2 shows the required tubing length needed to approximate the equivalent pressure resistance of the different types of Uponor ProPEX fittings.

Calculated Equivalent Tubing Length

Fitting Type	Tubing Size	
	¾"	1"
Tee - Run	2'	2'
Tee - 90°	6'	6'
90° Elbow	5'	6'
Coupling	2'	2'

Table 1-2: Pressure Resistance (Fittings/Tubing)

ProPEX Lead-free (LF) Brass Fire Sprinkler Adapter Tee

Submittal Information

Revision A: Nov. 20, 2009

Project Information

Job Name:

Location:

Part No. Ordered:

Engineer:

Date Submitted:

Contractor:

Submitted By:

Manufacturer's Representative:

Approved By:

Technical Data

Material: C69300 Brass

Product Information and Application Use

Designed for use with 3/4" or 1" Uponor AquaPEX® tubing, the ProPEX® Lead-free Brass Fire Sprinkler Adapter Tee connects fire sprinklers to the Uponor residential AquaSAFE™ Looped multipurpose fire safety system, which combines fire sprinklers with a home's potable cold-water plumbing system. Use Uponor ProPEX fittings for the connections.

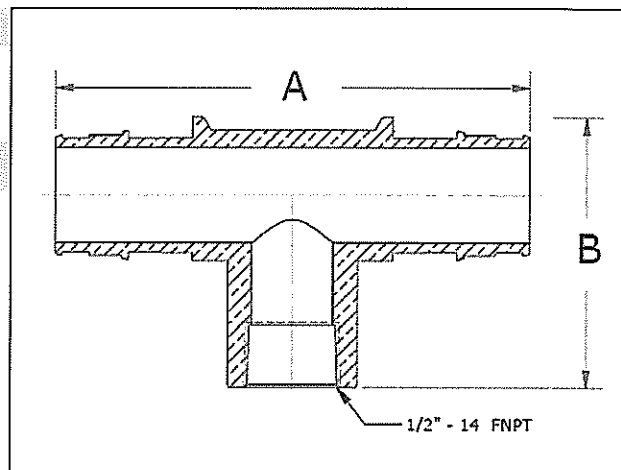

✓	Description	Part Number	A	B	Weight
<input type="checkbox"/>	ProPEX LF Brass Fire Sprinkler Adapter Tee, 1" PEX x 1" PEX x 1/2" FNPT	LF7701010	4.09"	2.325"	0.62 lbs.
<input type="checkbox"/>	ProPEX LF Brass Fire Sprinkler Adapter Tee, 3/4" PEX x 3/4" PEX x 1/2" FNPT	LF7707575	3.62"	2.325"	0.64 lbs.

Installation

Use the appropriate Uponor ProPEX Ring for the tubing. Install the tee using the Fire Sprinkler Adapter Mounting Bracket (A7750700) and Fire Sprinkler Adapter Push-on Nut (F7000005). For more information, refer to the Uponor AquaSAFE Looped System Installation Guide.

Related Products

A7750700: Fire Sprinkler Adapter Mounting Bracket, 3/4" and 1"

F7000005: Fire Sprinkler Adapter Push-on Nut

Standards

CAN/CSA B137.5; ASTM F877; ASTM F1960; UL 1821; ULC/ORD - C199P

Codes

IPC; UPC; NSPC; IRC; IMC; NPC of Canada

Listings

ANSI/NSF 14- and 61-certified; ICC ESR 1099; HUD MR 1269; IAPMO

Related Applications

PEX-a Plumbing Systems
AquaSAFE Fire Safety Systems

Contact Information

Uponor, Inc.
5925 148th Street West
Apple Valley, MN 55124 USA
Phone: (800) 321-4739
Fax: (952) 891-2008
www.uponor-usa.com

Uponor Ltd.
2000 Argentia Rd., Plaza 1, Ste. 200
Mississauga, ON L5N 1W1 CANADA
Phone: (888) 994-7726
Fax: (800) 638-9517
www.uponor.ca

¹ProPEX® is a registered trademark of Uponor, Inc. ProPEX™ is a trademark of Uponor Ltd.

Fire Sprinkler Adapter Mounting Bracket

Submittal Information
Revision A: Nov. 17, 2009

Project Information

Job Name:	
Location:	Part No. Ordered:
Engineer:	Date Submitted:
Contractor:	Submitted By:
Manufacturer's Representative:	Approved By:

Technical Data

Material: 1050 Annealed (spheroidized) spring steel

Product Information and Application Use

Uponor's Fire Sprinkler Adapter Mounting Bracket is designed to rigidly mount ProPEX® Lead-free Brass Fire Sprinkler Adapter Tees (LF7701010 and LF7707575) in Uponor AquaSAFE™ multi-purpose residential fire sprinkler systems.¹

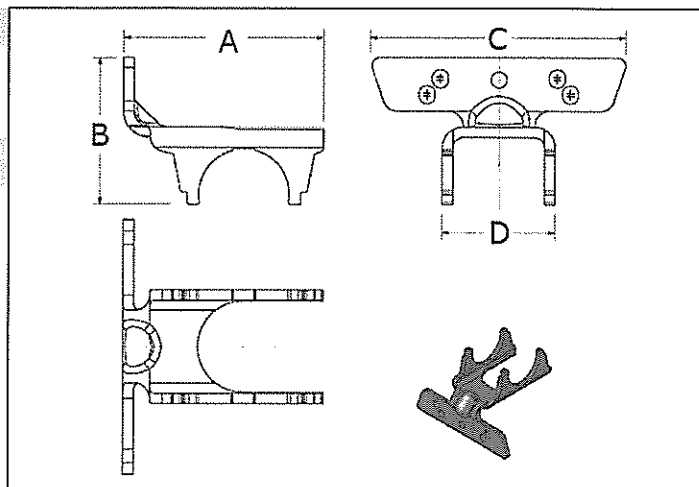

✓	Description	Part Number	A	B	C	D	Weight
<input type="checkbox"/>	Fire Sprinkler Adapter Mounting Bracket, 3/4" and 1"	A7750700	2.48"	1.84"	3.16"	1.42"	0.21 lbs.

Installation

Attach the sprinkler-mounting bracket or sprinkler adapter to the structure with two #10 x 1½" Pan Head, Full Thread Screws (F7001500) or equivalent. Refer to the sprinkler plan mounting details for correct placement of brackets and adapters, taking into account the ceiling type and sprinkler model. When installing adapter tee into bracket, use Fire Sprinkler Adapter Push-on Nut (F7000005). For more information, refer to the Uponor AquaSAFE Looped System Installation Guide.

Related Products

LF7701010: ProPEX Brass Fire Adapter Tee, 1" PEX x 1" PEX x ½" FNPT
LF7707575: ProPEX Brass Fire Adapter Tee, ¾" PEX x ¾" PEX x ½" FNPT

Standards

UL1821; ULC/ORD - C199P (for use with brass sprinkler adapter tees)

Codes

N/A

Listings

N/A

Related Applications

PEX-a Plumbing Systems
AquaSAFE Fire Safety Systems

Contact Information

Uponor, Inc.
5925 148th Street West
Apple Valley, MN 55124 USA
Phone: (800) 321-4739
Fax: (952) 891-2008
www.uponor-usa.com

Uponor Ltd.
2000 Argentia Rd., Plaza 1, Ste. 200
Mississauga, ON L5N 1W1 CANADA
Phone: (888) 994-7726
Fax: (800) 638-9517
www.uponor.ca

¹ProPEX® is a registered trademark of Uponor, Inc. ProPEX™ is a trademark of Uponor Ltd.

ProPEX® Fire Sprinkler Adapter

Submittal Information

Revision B: March 17, 2009

Project Information

Job Name:

Location:

Part No. Ordered:

Engineer:

Date Submitted:

Contractor:

Submitted By:

Manufacturer's Representative:

Approved By:

Technical Data

Material: 300 Series Stainless Steel

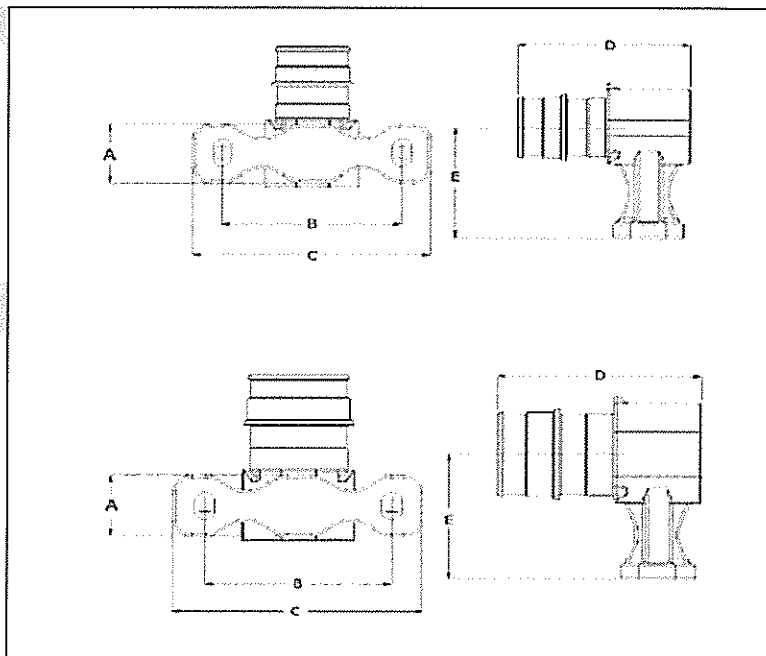

Product Information and Application Use

Use the ProPEX® Fire Sprinkler Adapter in conjunction with the appropriate sprinkler to provide a multi-purpose residential fire sprinkler system¹. For residential applications, the system is installed with the cold-potable portion of the Uponor plumbing system. Make connections with Uponor ProPEX fittings. These fittings are designed for use only with 3/4" or 1" AquaPEX® White tubing in the Uponor AQUASAFE® Looped System.

✓ Description	Part Number	A	B	C	D	E	Weight
<input type="checkbox"/> ProPEX Fire Sprinkler Adapter, 3/4" PEX x 1/2" FNPT	Q7517550	0.75"	1.88"	2.50"	1.82"	1.41"	0.268 lbs.
<input type="checkbox"/> ProPEX Fire Sprinkler Adapter, 1" PEX x 1/2" FNPT	Q7511050	0.75"	1.88"	2.50"	2.06"	1.54"	0.408 lbs.

Installation

Use appropriate ProPEX Ring for connecting the tubing. Refer to the AquaPEX Installation Handbook or the Uponor AQUASAFE® Installation Guide for additional information.

Standards

CAN/CSA B137.5; ASTM F877; ASTM F 1960

Codes

IPC; UPC; NSPC; IRC; IMC; NPC of Canada

Listings

ANSI/NSF 14- and 61-certified; U.P. Code; ICC ESR 1099; HUD MR 1269; UL 1821; ULC/ORD - C 199 P

Related Applications

PEX-a Plumbing Systems
AQUASAFE Fire Safety Systems

Contact Information

Uponor, Inc.
5925 148th Street West
Apple Valley, MN 55124 USA
Phone: (800) 321-4739
Fax: (952) 891-2008
www.uponor-usa.com

Uponor Ltd.
2000 Argentia Rd., Plaza 1, Ste. 200
Mississauga, ON L5N 1W1 CANADA
Phone: (888) 994-7726
Fax: (800) 638-9517
www.uponor.ca

¹ProPEX® is a registered trademark of Uponor, Inc. ProPEX™ is a trademark of Uponor Ltd.

ProPEX® Fire Sprinkler Adapter Elbow

Submittal Information
Revision B: March 17, 2009

Project Information

Job Name:

Location:

Part No. Ordered:

Engineer:

Date Submitted:

Contractor:

Submitted By:

Manufacturer's Representative:

Approved By:

Technical Data

Material: 300 Series Stainless Steel

Product Information and Application Use

Use the ProPEX® Fire Sprinkler Adapter Elbow in conjunction with the appropriate sprinkler to provide a multipurpose residential fire sprinkler system¹. The system is installed with the cold-potable portion of the Uponor plumbing system for residential applications. Make connections using Uponor ProPEX fittings. The fittings are designed for use only with ¾" or 1" AquaPEX® White tubing in the Uponor AQUASAFE® Looped System.

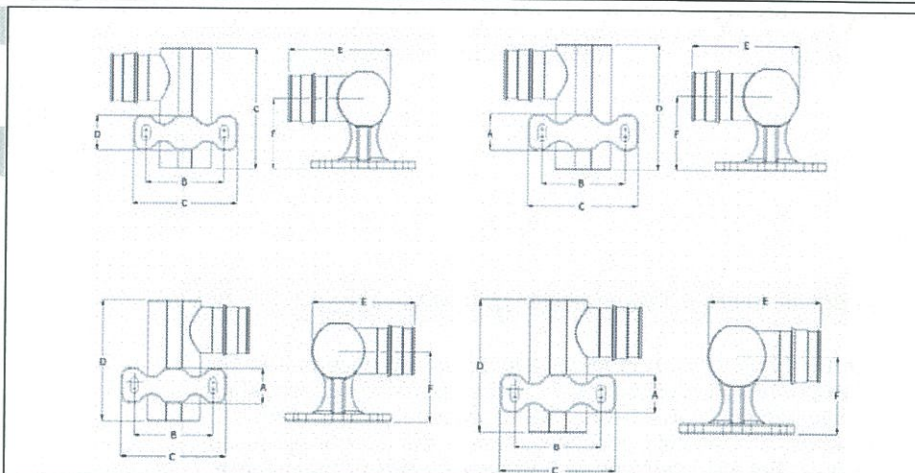

✓ Description	Part Number	A	B	C	D	E	F	Weight
<input type="checkbox"/> ProPEX Fire Sprinkler Adapter Right Elbow, ¾" PEX x ½" FNPT	Q7537550	2.25"	1.95"	1.41"	2.25"	1.95"	1.41"	0.410 lbs.
<input type="checkbox"/> ProPEX Fire Sprinkler Adapter Right Elbow, 1" PEX x ½" FNP	Q7531050	2.63"	2.43"	1.54"	2.63"	2.43"	1.54"	0.783 lbs.
<input type="checkbox"/> ProPEX Fire Sprinkler Adapter Left Elbow, ¾" PEX x ½" FNPT	Q7547550	2.25"	1.95"	1.41"	2.25"	1.95"	1.41"	0.410 lbs.
<input type="checkbox"/> ProPEX Fire Sprinkler Adapter Left Elbow, 1" PEX x ½" FNPT	Q7541050	2.63"	2.43"	1.54"	2.63"	2.43"	1.54"	0.783 lbs.

Installation

Use appropriate ProPEX Ring when connecting the tubing. Refer to the AquaPEX Installation Handbook or the Uponor AQUASAFE Installation Guide for additional information.

Standards

CAN/CSA B137.5; ASTM F877; ASTM F1960

Codes

IPC; UPC; NSPC; IRC; IMC; NPC of Canada

Listings

ANSI/NSF 14- and 61-certified; ICC ESR 1099; HUD MR 1269; IAPMO 3558; UL 1821; ULC/ORD - C 199 P

Related Applications

PEX-a Plumbing Systems
AQUASAFE Fire Safety Systems

Contact Information

Uponor, Inc.
5925 148th Street West
Apple Valley, MN 55124 USA
Phone: (800) 321-4739
Fax: (952) 891-2008
www.uponor-usa.com

Uponor Ltd.
2000 Argenta Rd., Plaza 1, Ste. 200
Mississauga, ON L5N 1W1 CANADA
Phone: (888) 994-7726
Fax: (800) 638-9517
www.uponor.ca

¹ProPEX® is a registered trademark of Uponor, Inc. ProPEX™ is a trademark of Uponor Ltd.

ProPEX® Ring

Submittal Information
Revision B: April 13, 2011

Project Information

Job Name:

Location:

Part No. Ordered:

Engineer:

Date Submitted:

Contractor:

Submitted By:

Manufacturer's Representative:

Approved By:

Technical Data

Material: PEX-a (Engel Method)

Density: 926 to 940 kg/m³

Degree of Crosslinking: 70% to 89%



Product Information and Application Use

Manufactured from PEX-a material, Uponor ProPEX® Rings are required to make a proper ProPEX connection.¹ Red print on the rings indicates hot lines. The ½", ¾" and 1" ProPEX Ring with Stop includes a leading edge chamfer and stop edge.

✓	Description	Part Number	Length	i.d.	o.d.	Weight
<input type="checkbox"/>	ProPEX Ring, ⅜"	Q4690302	0.54"	0.49"	0.74"	0.005 lbs.
<input type="checkbox"/>	ProPEX Ring with Stop, ½" (red print)	Q4690511	0.63"	0.63"	0.87"	0.006 lbs.
<input type="checkbox"/>	ProPEX Ring with Stop, ½"	Q4690512	0.63"	0.63"	0.87"	0.006 lbs.
<input type="checkbox"/>	ProPEX Ring, ⅝"	Q4680625	0.79"	0.75"	1.00"	0.008 lbs.
<input type="checkbox"/>	ProPEX Ring with Stop, ¾"	Q4690756	0.87"	0.88"	1.13"	0.012 lbs.
<input type="checkbox"/>	ProPEX Ring, 1"	Q4681000	1.10"	1.13"	1.42"	0.020 lbs.
<input type="checkbox"/>	ProPEX Ring with Stop, 1"	Q4691000	1.10"	1.13"	1.42"	0.020 lbs.
<input type="checkbox"/>	ProPEX Ring, 1¼"	Q4681250	1.35"	1.38"	1.66"	0.030 lbs.
<input type="checkbox"/>	ProPEX Ring, 1½"	Q4681500	1.61"	1.63"	1.91"	0.040 lbs.
<input type="checkbox"/>	ProPEX Ring, 2"	Q4682000	1.97"	2.14"	2.61"	0.133 lbs.

Installation

Square cut the Uponor ProPEX tubing. Remove excess material. Slide the ProPEX Ring over the end of the tubing (maximum 1/16" over-hang). When using the ½" ProPEX Ring with stop edge, slide the ring on (i.e., chamfered edge first) until the end of the tubing contacts the stop edge. Expand tubing and ring. Rotate tool a quarter turn after each expansion to prevent the formation of grooves. Remove the expansion tool and fully seat the tubing and ring against the shoulder of the fitting. You should make ProPEX connections at temperatures above 5°F / -15°C. For more information, refer to the AquaPEX® Professional Plumbing Installation Handbook, AquaSAFE™ Fire Safety Installation Guide or the Uponor Radiant Installation Handbook.

Standards

ASTM F1960

Codes

IPC; UPC; NSPC; NPC of Canada

Listings

UL 1821 (½", ¾" and 1"); ULC/ORD - C 199 P (½", ¾" and 1"); HUD MR 1269; ICC ESR 1099; ANSI/NSF 14- and 61-certified

Related Applications

PEX-a Plumbing Systems
Radiant Heating and Cooling Systems
AquaSAFE Fire Safety Systems

Contact Information

Uponor, Inc.
5925 148th Street West
Apple Valley, MN 55124 USA
Phone: (800) 321-4739
Fax: (952) 891-2008
www.uponor-usa.com

Uponor Ltd.
2000 Argentia Road, Plaza 1, Suite 200
Mississauga, ON L5N 1W1 CANADA
Phone: (888) 994-7726
Fax: (800) 638-9517
www.uponor.ca

¹ProPEX® is a registered trademark of Uponor, Inc. ProPEX™ is a trademark of Uponor Ltd.

ProPEX® Lead-free (LF) Brass Sweat Adapter

Submittal Information
Revision A: Jan. 20, 2010

Project Information

Job Name:

Location:

Part No. Ordered:

Engineer:

Date Submitted:

Contractor:

Submitted By:

Manufacturer's Representative:

Approved By:

Technical Data

Material: C69300 Brass

Product Information and Application Use

ProPEX® Lead-free Brass Sweat Adapters transition Uponor PEX tubing to copper pipe.¹ Adapters are approved for use in hot and cold potable water systems, hydronic radiant heating systems and the AquaSAFE™ Residential Fire Safety System. These adapters are safe for direct burial in soil.

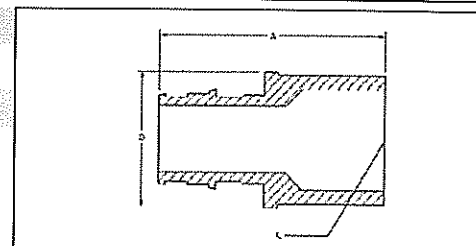

✓	Description	Part Number	A	B	C	Weight
<input type="checkbox"/>	ProPEX LF Brass Sweat Adapter, 3/8" PEX x 1/2" Copper	LF4513850	1.32"	0.721"	0.50" CU	0.08 lbs.
<input type="checkbox"/>	ProPEX LF Brass Sweat Adapter, 1/2" PEX x 1/2" Copper	LF4515050	1.44"	0.750"	0.50" CU	0.08 lbs.
<input type="checkbox"/>	ProPEX LF Brass Sweat Adapter, 1/2" PEX x 3/4" Copper	LF4515075	1.63"	0.989"	0.75" CU	0.16 lbs.
<input type="checkbox"/>	ProPEX LF Brass Sweat Adapter, 3/4" PEX x 1/2" Copper	LF4517550	1.67"	1.070"	0.50" CU	0.16 lbs.
<input type="checkbox"/>	ProPEX LF Brass Sweat Adapter, 3/4" PEX x 3/4" Copper*	LF4517575	2.04"	1.070"	0.75" CU	0.30 lbs.
<input type="checkbox"/>	ProPEX LF Brass Sweat Adapter, 3/4" PEX x 1" Copper	LF4517510	2.17"	1.258"	1.00" CU	0.31 lbs.
<input type="checkbox"/>	ProPEX LF Brass Sweat Adapter, 1" PEX x 1" Copper*	LF4511010	2.40"	1.345"	1.00" CU	0.30 lbs.
<input type="checkbox"/>	ProPEX LF Brass Sweat Adapter, 1 1/4" PEX x 1 1/4" Copper	LF4511313	2.63"	1.640"	1.25" CU	0.50 lbs.
<input type="checkbox"/>	ProPEX LF Brass Sweat Adapter, 1 1/2" PEX x 1 1/2" Copper	LF4511515	2.75"	1.875"	1.50" CU	0.50 lbs.
<input type="checkbox"/>	ProPEX LF Brass Sweat Adapter, 2" PEX x 2" Copper	LF4512020	3.53"	3.00"	2.00" CU	2.00 lbs.

Installation

Use the appropriate Uponor ProPEX Ring for the tubing (sold separately). Do not solder within 18 inches of the ProPEX Fitting. Refer to AquaPEX® Professional Plumbing Installation Guide, Radiant Floor Heating Installation Handbook or AquaSAFE™ Residential Fire Sprinkler Installation Guide for additional information.

Standards

CAN/CSA B137.5; ASTM F877; ASTM F1960

Codes

IPC; UPC; NSPC; NPC of Canada

Listings

HUD MR 1269; ICC ESR 1099; ANSI/NSF 14- and 61-certified; U.P. Code, Annex G; *UL 1821; *ULC/ORD C199P

Related Applications

PEX-a Plumbing Systems
Uponor Residential Fire Safety Systems
Radiant Heating and Cooling Systems
Snow and Ice Melting Systems
Permafrost Protection Systems
Turf Conditioning Systems

Contact Information

Uponor, Inc.
5925 148th Street West
Apple Valley, MN 55124 USA
Phone: (800) 321-4739
Fax: (952) 891-1409
www.uponor-usa.com

Uponor Ltd.
2000 Argentia Rd., Plaza 1, Ste. 200
Mississauga, ON L5N 1W1 CANADA
Phone: (888) 994-7726
Fax: (800) 638-9517
www.uponor.ca

¹ProPEX® is a registered trademark of Uponor, Inc. ProPEX™ is a trademark of Uponor Ltd.

ProPEX® Lead-free (LF) Brass Female Threaded Adapter

Submittal Information
Revision A: Jan. 20, 2010

Project Information

Job Name:

Location:

Part No. Ordered:

Engineer:

Date Submitted:

Contractor:

Submitted By:

Manufacturer's Representative:

Approved By:

Technical Data

Material: C69300 Brass

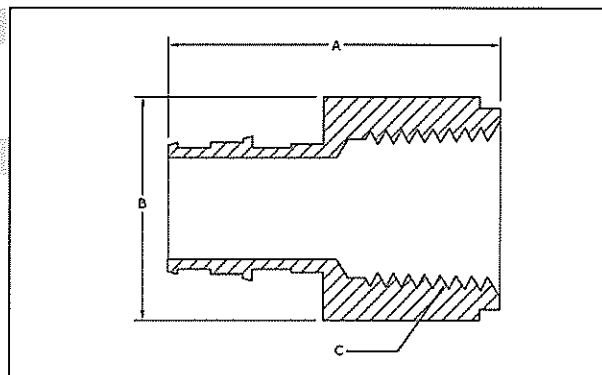

Product Information and Application Use

The ProPEX® Lead-free Brass Female Threaded Adapter connects Uponor PEX tubing to female NPT threads.¹ Use these fittings in hot and cold domestic potable water systems or in any radiant heating system. One end of the adapter is manufactured with the Uponor ProPEX Fitting for connections to Wirsbo hePEX™ tubing or Uponor AquaPEX® tubing. The other end of the adapter connects to copper. These adapters are safe for direct burial in soil.

✓	Description	Part Number	A	B	C	Weight
<input type="checkbox"/>	ProPEX LF Brass Female Threaded Adapter, ½" PEX x ½" NPT	LF4575050	1.57"	1" HEX	½" NPT	0.20 lbs.
<input type="checkbox"/>	ProPEX LF Brass Female Threaded Adapter, ½" PEX x ¾" NPT	LF4575075	1.75"	1⅜" HEX	¾" NPT	0.40 lbs.
<input type="checkbox"/>	ProPEX LF Brass Female Threaded Adapter, ¾" PEX x ¾" NPT*	LF4577575	1.87"	1⅝" HEX	¾" NPT	0.20 lbs.
<input type="checkbox"/>	ProPEX LF Brass Female Threaded Adapter, ¾" PEX x 1" NPT	LF4577510	2.21"	1½" HEX	1" NPT	0.40 lbs.
<input type="checkbox"/>	ProPEX LF Brass Female Threaded Adapter, 1" PEX x 1" NPT	LF4571010	2.44"	1½" HEX	1" NPT	0.45 lbs.
<input type="checkbox"/>	ProPEX LF Brass Female Threaded Adapter, 1¼" PEX x 1¼" NPT	LF4571313	2.57"	2" HEX	1¼" NPT	1.00 lbs.
<input type="checkbox"/>	ProPEX LF Brass Female Threaded Adapter, 1½" PEX x 1½" NPT	LF4571515	2.75"	2½" HEX	1½" NPT	2.20 lbs.
<input type="checkbox"/>	ProPEX Brass Female Threaded Adapter, 2" PEX x 2" NPT	LF4572020	3.53"	3" HEX	2" NPT	2.20 lbs.

Installation

ProPEX Tool and ProPEX Rings (sold separately) are required for connecting the PEX tubing. For more information, refer to the AquaPEX Professional Plumbing Installation Guide or the Radiant Floor Heating Installation Handbook.

Standards

CAN/CSA B137.5; ASTM F877; ASTM F1960

Codes

IPC; UPC; NSPC; NPC of Canada

Listings

ANSI/NSF 14- and 61-certified; ICC ESR 1099; HUD MR 1269; U.P. Code, Annex G; *UL 1821; *ULC/ORD C199P

Related Applications

PEX-a Plumbing Systems
Radiant Heating and Cooling Systems
Snow and Ice Melting Systems
Permafrost Protection Systems
Turf Conditioning Systems

Contact Information

Uponor, Inc.
5925 148th Street West
Apple Valley, MN 55124 USA
Phone: (800) 321-4739
Fax: (952) 891-1409
www.uponor-usa.com

Uponor Ltd.
2000 Argentia Rd., Plaza 1, Ste. 200
Mississauga, ON L5N 1W1 CANADA
Phone: (888) 994-7726
Fax: (800) 638-9517
www.uponor.ca

¹ProPEX® is a registered trademark of Uponor, Inc. ProPEX™ is a trademark of Uponor Ltd.

ProPEX® Lead-free (LF) Brass Male Threaded Adapter

Submittal Information
Revision A: Jan. 28, 2010

Project Information

Job Name:

Location:

Part No. Ordered:

Engineer:

Date Submitted:

Contractor:

Submitted By:

Manufacturer's Representative:

Approved By:

Technical Data

Material: C69300 Brass

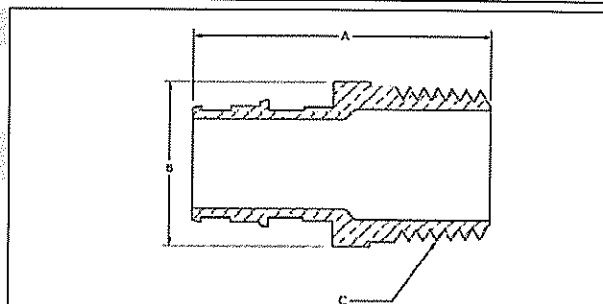

Product Information and Application Use

ProPEX® Lead-free Male Threaded Adapters connect Uponor PEX tubing to male NPT threads.¹ These adapters are safe for direct burial in soil.

✓	Description	Part Number	A	B	C	Weight
<input type="checkbox"/>	ProPEX LF Brass Male Threaded Adapter, 3/8" PEX x 1/2" NPT	LF4523850	1.62"	7/8" HEX	1/2" NPT	0.11 lbs.
<input type="checkbox"/>	ProPEX LF Brass Male Threaded Adapter, 1/2" PEX x 1/2" NPT	LF4525050	1.73"	7/8" HEX	1/2" NPT	0.32 lbs.
<input type="checkbox"/>	ProPEX LF Brass Male Threaded Adapter, 1/2" PEX x 3/4" NPT	LF4525075	1.78"	1 1/8" HEX	3/4" NPT	0.18 lbs.
<input type="checkbox"/>	ProPEX LF Brass Male Threaded Adapter, 3/4" PEX x 3/4" NPT*	LF4527575	2.02"	1 1/8" HEX	3/4" NPT	0.20 lbs.
<input type="checkbox"/>	ProPEX LF Brass Male Threaded Adapter, 3/4" PEX x 1" NPT*	LF4527510	2.22"	1 3/8" HEX	1" NPT	0.35 lbs.
<input type="checkbox"/>	ProPEX LF Brass Male Threaded Adapter, 1" PEX x 3/4" NPT	LF4521075	2.25"	1 1/4" HEX	3/4" NPT	0.30 lbs.
<input type="checkbox"/>	ProPEX LF Brass Male Threaded Adapter, 1" PEX x 1" NPT*	LF4521010	2.46"	1 3/8" HEX	1" NPT	0.44 lbs.
<input type="checkbox"/>	ProPEX LF Brass Male Threaded Adapter, 1 1/4" PEX x 1 1/4" NPT	LF4521313	2.72"	1 3/4" HEX	1 1/4" NPT	0.75 lbs.
<input type="checkbox"/>	ProPEX LF Brass Male Threaded Adapter, 1 1/2" PEX x 1 1/2" NPT	LF4521515	3.00"	2 1/4" HEX	1 1/2" NPT	0.80 lbs.
<input type="checkbox"/>	ProPEX Brass Male Threaded Adapter, 2" PEX x 2" NPT	LF4522020	3.86"	2 1/2" HEX	2" NPT	1.90 lbs.

Installation

ProPEX Tool and ProPEX Rings (sold separately) are required for connecting the PEX tubing. Refer to the AquaPEX® Professional Plumbing Installation Guide or Radiant Floor Heating Installation Handbook for additional information.

Standards

CAN/CSA B137.5; ASTM F877; ASTM F1960

Codes

IPC; UPC; NSPC; NPC of Canada

Listings

ANSI/NSF 14- and 61-certified; HUD MR 1269; ICC ESR 1099; IAPMO 3558; U.P. Code, Annex G; *UL 1821; *ULC/ORD C199P

Related Applications

PEX-a Plumbing Systems
Radiant Heating and Cooling Systems
Snow and Ice Melting Systems
Permafrost Protection Systems
Turf Conditioning Systems

Contact Information

Uponor, Inc.
5925 148th Street West
Apple Valley, MN 55124 USA
Phone: (800) 321-4739
Fax: (952) 891-1409
www.uponor-usa.com

Uponor Ltd.
2000 Argentia Rd., Plaza 1, Ste. 200
Mississauga, ON L5N 1W1 CANADA
Phone: (888) 994-7726
Fax: (800) 638-9517
www.uponor.ca

¹ProPEX® is a registered trademark of Uponor, Inc. ProPEX™ is a trademark of Uponor Ltd.

ProPEX® Lead-free (LF) Brass Coupling

Submittal Information
Revision A: Jan. 28, 2010

Project Information

Job Name:

Location:

Part No. Ordered:

Engineer:

Date Submitted:

Contractor:

Submitted By:

Manufacturer's Representative:

Approved By:

Technical Data

Material C69300 Brass

Product Information and Application Use

ProPEX® Lead-free Brass Couplings are available for use in hot and cold domestic potable water systems.¹ Also approved for use in any radiant heating system. The coupling features the Uponor ProPEX Fitting for connections to Wirsbo hePEX™ tubing or Uponor AquaPEX® tubing. Couplings are safe for direct burial in soil.

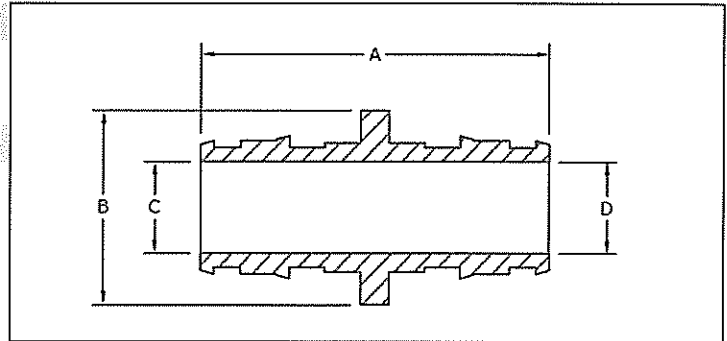

✓	Description	Part Number	A	B	C	D	Weight
<input type="checkbox"/>	ProPEX LF Brass Coupling, 3/8" PEX x 1/2" PEX	LF4543850	1.42"	0.740"	0.398"	0.280"	0.05 lbs
<input type="checkbox"/>	ProPEX LF Brass Coupling, 1/2" PEX x 1/2" PEX*	LF4545050	1.54"	0.740"	0.398"	N/A	0.07 lbs
<input type="checkbox"/>	ProPEX LF Brass Coupling, 3/4" PEX x 3/4" PEX*	LF4547575	2.02"	1.187"	0.595"	N/A	0.13 lbs
<input type="checkbox"/>	ProPEX LF Brass Coupling, 3/4" PEX x 1" PEX*	LF4547510	2.25"	1.345"	0.795"	0.595"	0.16 lbs
<input type="checkbox"/>	ProPEX LF Brass Coupling, 1" PEX x 1" PEX*	LF4541010	2.49"	1.345"	0.818"	N/A	0.20 lbs

Installation

ProPEX Tool and ProPEX Rings (sold separately) are required for connecting the PEX tubing. Use the appropriately sized Uponor ProPEX Ring for tubing connections. For more information, refer to the AquaPEX Professional Plumbing Installation Guide, the AquaSAFE™ Residential Fire Sprinkler Installation Guide or the Radiant Floor Heating Installation Handbook.

Standards

CAN/CSA B137.5; ASTM F877; ASTM F1960

Codes

IPC; UPC; NSPC; NPC of Canada

Listings

IAMPO 3558; HUD MR 1269; ICC ESR 1099; NSF 14- and 61-certified; U.P. Code, Annex G; *UL 1821; *ULC/ORD C199P

Related Applications

PEX-a Plumbing Systems
Uponor Residential Fire Safety Systems
Radiant Heating and Cooling Systems
Snow and Ice Melting Systems
Permafrost Protection Systems
Turf Conditioning Systems

Contact Information

Uponor, Inc.
5925 148th Street West
Apple Valley, MN 55124 USA
Phone: (800) 321-4739
Fax: (952) 891-2008
www.uponor-usa.com

Uponor Ltd.
2000 Argentia Rd., Plaza 1, Ste. 200
Mississauga, ON L5N 1W1 CANADA
Phone: (888) 994-7726
Fax: (800) 638-9517
www.uponor.ca

¹ProPEX® is a registered trademark of Uponor, Inc. ProPEX™ is a trademark of Uponor Ltd.

ProPEX® Brass Elbow

Submittal Information
Revision B: March 17, 2009

Project Information

Job Name:

Location:

Part No. Ordered:

Engineer:

Date Submitted:

Contractor:

Submitted By:

Manufacturer's Representative:

Approved By:

Technical Data

Material: B16 Copper Alloy UNS C36000

Product Information and Application Use

The brass ProPEX® Elbow is available for use in hot and cold domestic potable water systems, and in the AQUASAFE® Residential Fire Safety systems. Also approved for use in any hydronic heating and AquaPEX® plumbing systems, each end of the elbow is manufactured with the ProPEX fitting for connections to hePEX™ or any AquaPEX tubing.

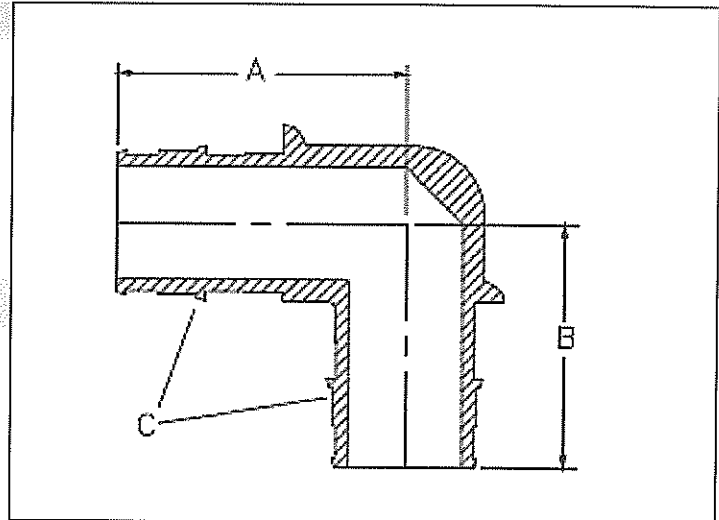

✓ Description	Part Number	A	B	C	Weight
<input type="checkbox"/> ProPEX Brass Elbow, 1/2" PEX x 1/2" PEX*	Q4710500	1.45"	1.48"	0.500"	0.10 lbs.
<input type="checkbox"/> ProPEX Brass Elbow, 5/8" PEX x 5/8" PEX	Q4710625	1.77"	1.57"	0.625"	0.15 lbs.
<input type="checkbox"/> ProPEX Brass Elbow, 3/4" PEX x 3/4" PEX*	Q4710750	2.04"	1.75"	0.750"	0.20 lbs.
<input type="checkbox"/> ProPEX Brass Elbow, 1" PEX x 1" PEX*	Q4711000	2.61"	2.28"	1.000"	0.30 lbs.
<input type="checkbox"/> ProPEX Brass Elbow, 2" PEX x 2" PEX	Q4712000	4.66"	4.36"	2.000"	2.20 lbs.

Installation

Use appropriate ProPEX Ring for connecting the tubing. Refer to the AquaPEX Installation Handbook, the Radiant Floor Installation Handbook or the Uponor AQUASAFE® Installation Guide for additional information.

Standards

CAN/CSA B137.5; ASTM F877; ASTM F 1960

Codes

IPC; UPC; NSPC; NPC of Canada

Listings

ANSI/NSF 14- and 61-certified; U.P. Code; ICC ESR 1099; HUD MR 1269; *UL 1821; *ULC/ORD C199P

Related Applications

PEX-a Plumbing Systems
AQUASAFE Fire Safety Systems
Uponor Radiant Floor heating Systems

Contact Information

Uponor, Inc.
5925 148th Street West
Apple Valley, MN 55124 USA
Phone: (800) 321-4739
Fax: (952) 891-2008
www.uponor-usa.com

Uponor Ltd.
2000 Argentia Rd., Plaza 1, Ste. 200
Mississauga, ON L5N 1W1 CANADA
Phone: (888) 994-7726
Fax: (800) 638-9517
www.uponor.ca

¹ProPEX® is a registered trademark of Uponor, Inc. ProPEX™ is a trademark of Uponor Ltd.

ProPEX® Lead-free (LF) Brass Tee

Submittal Information
Revision B: Jan. 28, 2010

Project Information

Job Name:	
Location:	Part No. Ordered:
Engineer:	Date Submitted:
Contractor:	Submitted By:
Manufacturer's Representative:	Approved By:

Technical Data

Material: C69300 Brass

Product Information and Application Use

Uponor's ProPEX® Lead-free Brass Tees are ideal for use in hot and cold domestic potable water systems.¹

This product is approved for use in the AquaSAFE™ Residential Fire Safety System. Also approved for any hydronic heating system application.

Each end of the ProPEX LF Brass Tee is manufactured with the Uponor ProPEX Fitting for connections to Wirsbo hePEX™ or Uponor AquaPEX® tubing. This product is safe for direct burial in soil.



✓	Description	Part Number	Length	Width	Weight
<input type="checkbox"/>	ProPEX LF Brass Tee, ½" PEX x ½" PEX x ½" PEX	LF4705050	2.52"	1.45"	0.20 lbs.
<input type="checkbox"/>	ProPEX LF Brass Tee, ¾" PEX x ¾" PEX x ¾" PEX	LF4707575	3.27"	1.93"	0.40 lbs.
<input type="checkbox"/>	ProPEX LF Brass Tee, 1" PEX x 1" PEX x 1" PEX	LF4701010	4.09"	2.42"	0.40 lbs.

Installation

ProPEX Tool and ProPEX Rings (sold separately) are required for connecting the PEX tubing. Do not solder within 18 inches of the ProPEX connection. Refer to the AquaPEX Professional Plumbing Installation Guide, AquaSAFE Homeowner Handbook or Radiant Floor Heating Installation Handbook for additional information.

Standards

CSA B137.5; ASTM F877; ASTM F1960

Codes

IPC; UPC; NSPC; NPC of Canada

Listings

IAPMO 3558; ANSI/NSF 14- and 61-certified; HUD MR 1269; ICC ESR 1099; UL 1821; ULC/ORD C 199P; U.P. Code, Annex G

Related Applications

PEX-a Plumbing Systems
Uponor Residential Fire Safety Systems
Radiant Heating and Cooling Systems

Contact Information

Uponor, Inc.
5925 148th Street West
Apple Valley, MN 55124 USA
Phone: (800) 321-4739
Fax: (952) 891-2008
www.uponor-usa.com

Uponor Ltd.
2000 Argenta Rd., Plaza 1, Ste. 200
Mississauga, ON L5N 1W1 CANADA
Phone: (888) 994-7726
Fax: (800) 638-9517
www.uponor.ca

¹ProPEX® is a registered trademark of Uponor, Inc. ProPEX™ is a trademark of Uponor Ltd.

ProPEX® Lead-free (LF) Brass Reducing Tee

Submittal Information
Revision B: Jan. 28, 2010

Project Information

Job Name:

Location:

Part No. Ordered:

Engineer:

Date Submitted:

Contractor:

Submitted By:

Manufacturer's Representative:

Approved By:

Technical Data

Material: C69300 Brass

Product Information and Application Use

Uponor's ProPEX® LF Brass Reducing Tee makes diverting connections for Uponor PEX tubing in supply and return mains.¹ This product is available for use in hot and cold domestic potable water systems, in any hydronic heating system and in the AquaSAFE™ Residential Fire Safety System. Uponor manufactures each end of the tee with the ProPEX Fitting for easy connections to Wirsbo hePEX™ or Uponor AquaPEX® tubing. This product is safe for direct burial in soil.

Note: Branch size is listed last in the part description.

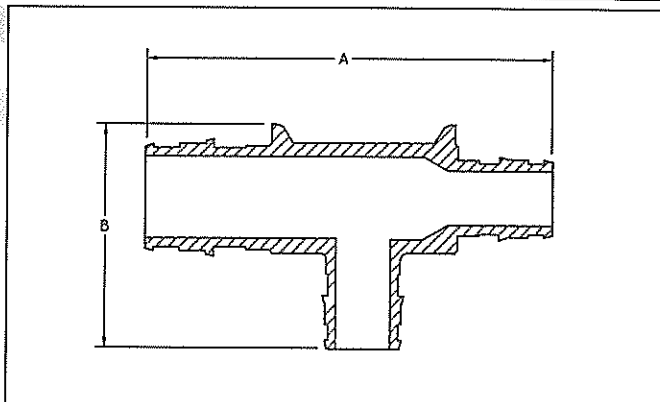

✓ Description	Part Number	A	B	Weight
<input type="checkbox"/> ProPEX LF Brass Reducing Tee, ¾" PEX x ¾" PEX x ½" PEX	LF4707550	3.27"	1.69"	0.40 lbs.
<input type="checkbox"/> ProPEX LF Brass Reducing Tee, ¾" PEX x ¾" PEX x 1" PEX	LF4707710	3.62"	2.42"	0.50 lbs.
<input type="checkbox"/> ProPEX LF Brass Reducing Tee, 1" PEX x ¾" PEX x ¾" PEX	LF4701775	3.86"	2.18"	0.30 lbs.
<input type="checkbox"/> ProPEX LF Brass Reducing Tee, 1" PEX x ¾" PEX x 1" PEX	LF4701751	3.86"	2.42"	0.40 lbs.
<input type="checkbox"/> ProPEX LF Brass Reducing Tee, 1" PEX x 1" PEX x ½" PEX	LF4701150	4.09"	1.95"	0.40 lbs.
<input type="checkbox"/> ProPEX LF Brass Reducing Tee, 1" PEX x 1" PEX x ¾" PEX	LF4701175	4.09"	2.18"	0.40 lbs.

Installation

ProPEX Tool and ProPEX Rings (sold separately) are required for connecting PEX tubing. Refer to the AquaPEX Professional Plumbing Installation Guide, the AquaSAFE Residential Fire Sprinkler Installation Guide or the Radiant Floor Heating Installation Handbook for additional information.

Standards

CAN/CSA B137.5; ASTM F877; ASTM F1960

Codes

IPC; UPC; NSPC; NPC of Canada

Listings

IAPMO 3558; ANSI/NSF 14- and 61-certified; HUD MR 1269; ICC ESR 1099; UL 1821; ULC/ORD C 199P; U.P. Code, Annex G

Related Applications

PEX-a Plumbing Systems
Uponor Residential Fire Safety Systems
Radiant Heating and Cooling Systems
Snow and Ice Melting Systems
Permafrost Protection Systems
Turf Conditioning Systems

Contact Information

Uponor, Inc.
5925 148th Street West
Apple Valley, MN 55124 USA
Phone: (800) 321-4739
Fax: (952) 891-2008
www.uponor-usa.com

Uponor Ltd.
2000 Argenta Rd., Plaza 1, Ste. 200
Mississauga, ON L5N 1W1 CANADA
Phone: (888) 994-7726
Fax: (800) 638-9517
www.uponor.ca

¹ProPEX® is a registered trademark of Uponor, Inc. ProPEX™ is a trademark of Uponor Ltd.

1" Branch Manifold with 1/2" ProPEX® Lead-free (LF) Outlets

Submittal Information
Revision A: Jan. 28, 2010

Project Information

Job Name:

Location:

Part No. Ordered:

Engineer:

Date Submitted:

Contractor:

Submitted By:

Manufacturer's Representative:

Approved By:

Technical Data

Material:	Type L Copper; C69300 Brass
Maximum Temperature (no pressure):	320°F (160°C)
Maximum Working Temperature/Pressure:	210°F at 150 psi (99°C at 10 bar)
Maximum Flow Rate at 5 fps:	12.8 gpm
Maximum Flow Rate at 8 fps:	20.5 gpm

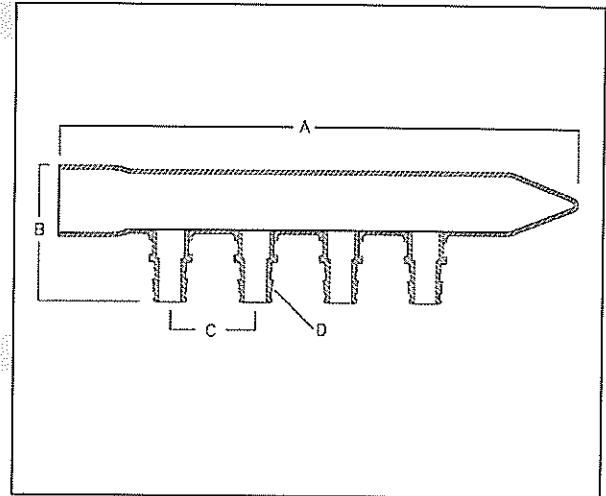

Product Information and Application Use

The Uponor 1" Copper Branch Manifold with 1/2" ProPEX® Lead-free outlets is used for hot and cold domestic potable water distribution systems.¹ The manifold has a 1" copper sweat fitting adapter supply connection. All outlets are configured with 1/2" ProPEX Lead-free brass connections.

✓ Description	Part Number	A	B	C	D	Weight
<input type="checkbox"/> 1" Branch Manifold with 1/2" ProPEX LF outlets, 4 outlets	LF2801050	8.95"	2.40"	1.50"	1/2"	0.80 lbs.
<input type="checkbox"/> 1" Branch Manifold with 1/2" ProPEX LF outlets, 6 outlets	LF2811050	11.95"	2.40"	1.50"	1/2"	1.10 lbs.
<input type="checkbox"/> 1" Branch Manifold with 1/2" ProPEX LF outlets, 8 outlets	LF2821050	14.95"	2.40"	1.50"	1/2"	1.40 lbs.
<input type="checkbox"/> 1" Branch Manifold with 1/2" ProPEX LF outlets, 10 outlets	LF2831050	17.95"	2.40"	1.50"	1/2"	1.70 lbs.
<input type="checkbox"/> 1" Branch Manifold with 1/2" ProPEX LF outlets, 12 outlets	LF2841050	20.95"	2.40"	1.50"	1/2"	1.90 lbs.

Installation

Use any product designed to mount 1" copper pipe as a mounting bracket. Any bend within 6 inches of the ProPEX connection to the manifold requires the use of a Tube Talon (F7050750) or Bend Support (A5110500 and A5150500). Refer to the AquaPEX® Professional Plumbing Installation Guide or the AquaSAFE™ Residential Fire Sprinkler Installation Guide for additional information.

Standards

CAN/CSA B137.5; ASTM F877; ASTM F1960

Codes

IPC; UPC; NSPC; NPC of Canada

Listings

UL 1821; ULC/ORD - C 199P; ICC ESR 1099; ANSI/NSF 14- and 61-certified; IAPMO; U.P. Code, Annex G

Related Applications

PEX-a Plumbing Systems
Uponor Residential Fire Safety Systems
Radiant Heating and Cooling Systems

Contact Information

Uponor, Inc.
5925 148th Street West
Apple Valley, MN 55124 USA
Phone: (800) 321-4739
Fax: (952) 891-2008
www.uponor-usa.com







Uponor Ltd.
2000 Argenta Rd., Plaza 1, Ste. 200
Mississauga, ON L5N 1W1 CANADA
Phone: (888) 994-7726
Fax: (800) 638-9517
www.uponor.ca

¹ProPEX® is a registered trademark of Uponor, Inc. ProPEX™ is a trademark of Uponor Ltd.

Reliable®

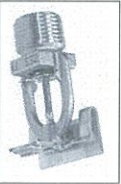
Model F1 Res and RFC Residential Sprinkler Design and Installation Guide

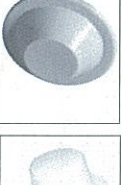
Bulletin 140 Rev J

			
F1 Res 30/30L Pendent 49/49L, 58/58L & 76	F1 Res 30/30L Recessed Pendent/F1 49/49L, 58/58L & 76	F1 Res 30/30L Recessed Pendent/FP 49/49L, 58/58L & 76	F1 Res 44/44L HSW
			
F1 Res 44/44L Recessed HSW/F2 & 58/58L	F1 Res 44/44L SWC 49/49L, 58/58L & 76	RFC 30/30L 49/49L, 49/49L	RFC 56

Sprinkler Model and Type	Sprinkler Identification Number	Reliable Bulletin Number
F1 Res 30/30L Pendent	R3511	Horizontal Ceilings - 135, 033
F1 Res 30/30L Recessed Pendent/F1	RA3311	Horizontal Ceilings - 135, 033
F1 Res 30/30L Recessed Pendent/CP		
F1 Res 49/49L Pendent	R3516, RA3316	Horizontal Ceilings - 135, 033
F1 Res 49/49L Recessed Pendent/F1		
F1 Res 49/49L Recessed Pendent/FP		
F1 Res 49/49L Concealed Pendent/CCP		
F1 Res 58/58L Pendent	R3513, RA3313	Horizontal Ceilings - 135, 033
F1 Res 58/58L Recessed Pendent/F1		
F1 Res 58/58L Recessed Pendent/FP		
F1 Res 58/58L Concealed Pendent/CCP		
RFC 30/30L, 43/43L & 49/49L Concealed Pendent	RA0811, RA0612, RA0616, RA3211, RA3212, RA3216	Horizontal Ceilings - 006, 032 Sloped Ceilings - 035
RFC 56 Concealed Pendent	RA0914	Horizontal Ceilings - 009
F1 Res 44/44L Horizontal Sidewall	R3531, RA3331	Horizontal Ceilings - 135, 033
F1 Res 44/44L Recessed Horizontal Sidewall		Sloped Ceilings - 035
F1 Res 44/44L SWC Concealed Horizontal Sidewall	R3531, RA3331	Horizontal Ceilings - 135, 033
F1 Res 58/58L Horizontal Sidewall	R3533, RA3335	Horizontal Ceilings - 135, 033
F1 Res 58/58L Recessed Horizontal Sidewall/FP		
F1 Res 76 Pendent/F1 Res 76 Recessed Pendent/F1	R7618	Horizontal Ceilings - 135, 176
F1 Res 76 Recessed Pendent/FP		
F1 Res 76 Concealed Pendent/CCP		

Table A
Model F1 Res and Model RFC Residential Sprinklers

The Reliable Automatic Sprinkler Co., Inc., 103 Fairview Park Drive, Elmstord, New York 10523

General

Reliable residential sprinklers utilize a fast response thermal element and are intended for use in only wet-pipe residential sprinkler systems designed in accordance with the following NFPA standards: NFPA 13D, Installation of Sprinkler Systems for One- and Two-Family Dwellings and Manufactured Homes; NFPA 13R, Installation of Sprinkler Systems for Residential Occupancies Up to and including Four Stories in Height; and for the residential portions of any occupancy as permitted by NFPA 13, Installation of Sprinkler Systems. Fast response and high wall wetting characteristics of residential sprinklers improve life safety by maintaining a tenable environment, providing escape time for occupants. NFPA 13D is appropriate for protection against fire hazards only in one- and two-family dwellings and manufactured homes. Residential portions of any other type of building or occupancy should be protected with residential sprinklers in accordance with NFPA 13, or in accordance with NFPA 13R. NFPA 13R is appropriate for use as an option to NFPA 13 only in those residential occupancies up to and including four stories in height. Where buildings are greater than four stories in height, or where buildings are of mixed use where residential is not the predominant occupancy, protect residential portions of such buildings with residential or quick response sprinklers in accordance with NFPA 13.

This document provides design guidelines for the Model F1/Res and RFC Residential Sprinklers shown in Table A, which are cULUs Listed to provide a minimum density of 0.05 gpm/ft², in accordance with the above-mentioned standards, manufacturer's instructions, and technical bulletins. Where documentation for residential sprinkler systems does not exist for particular applications, information based on NFPA 13 is used.

Residential fire sprinkler systems should only be designed and installed by competent individuals trained and experienced with automatic sprinkler system design and installation. Several criteria may apply to a given installation and the designer and/or installer must be familiar with the applicable codes, standards, and guidelines governing such an installation. The Reliable Model F1/Res and RFC residential sprinklers described herein must be installed and maintained in compliance with this document manufacturer's recommendations, with the latest published standards of the National Fire Protection Association (NFPA), and with any additional local jurisdictional requirements. Failure to comply may result in the impairment of sprinkler integrity and proper operation. Because of the various features of residential type architecture, there will be some compartment designs which cannot be fully sprinklered in accordance with the recommendations of NFPA 13, 13D, or 13R. In these instances, consult the Authority Having Jurisdiction for guidance and approval.

The owner is responsible for maintaining their fire protection system and associated devices in proper operating condition. Refer to NFPA 25, Inspection, Testing, and Maintenance of Water-Based Fire Protection Systems, for guidance on testing and maintenance of automatic sprinkler systems.

Approvals

All Reliable residential sprinklers have been designed and tested in accordance with the latest Edition of Underwriters Laboratories (UL) 1626, Standard for Residential Sprinklers for Fire Protection Service. Typically, they are cULUs Listed for installation under smooth, flat ceilings of unobstructed construction, unless otherwise noted in the specific listings, with specific approved spacing, flows, and pressures. Reliable residential sprinklers are cULUs Listed for installation on both horizontal ceilings with a maximum slope of 27/12 (9.4°) pitch, and sloped ceilings (where applicable) having maximum slopes of 4/12 (18.4°) and 8/12 (33.7°) pitch. The design criteria for residential sprinklers contained in the current NFPA 13D, 13R, and 13 Standards must be followed except as modified by the individual UL 1626 listing information, the information in the Reliable residential sprinkler bulletins, and this installation guide. The Authority Having Jurisdiction (AHJ) must make final approval for all residential sprinkler installations for compliance with all applicable codes, standards, and jurisdictional requirements.

One of the most important revisions of the Third Edition of UL 1626 is the new minimum density requirement for residential sprinklers manufactured after July 12, 2002. When establishing a minimum cULUs Listed flow rate, the manufacturer must use a minimum discharge rate over the specified coverage area corresponding to a 0.05 gpm/ft² density. In some cases, however, to successfully pass the UL 1626 fire tests, the UL Listed flow rate may be greater than the calculated 0.05 gpm/ft² density. Increased flow rates for horizontal sidewall type sprinklers, which exceed this minimum density, is common. Because this minimum density is a listing requirement, the use of residential sprinklers meeting this criterion is applicable to all editions of NFPA 13, 13R and 13D. The design criteria for residential sprinklers contained in the current NFPA Standards must be followed except as modified by the individual cULUs Listing information provided in the technical bulletins referenced in Table A.

Definitions

The following NFPA definitions are applicable to the terms used in this installation guide. Where terms are not included, refer to NFPA 13, NFPA 13D and NFPA 13R for official definitions:

Residential Sprinkler – A type of fast-response sprinkler that has a thermal element with an RTI of 50 (m-s)² or less, has been specifically tested for its ability to enhance survivability in the room of fire origin and listed for use in the protection of dwelling units. Residential sprinklers possess a fast response thermal element and produce a spray pattern that discharges water higher on the wall than a standard spray sprinkler.

Dwelling – Any building that contains not more than one or two dwelling units intended to be used, rented, leased, let or hired out to be occupied or that are occupied for habitation purposes.

Dwelling Unit – One or more rooms, arranged for the use of one or more individuals living together, as in a single housekeeping unit, that normally have cooking, living, sanitary, and sleeping facilities. Dwelling units include hotel rooms, dormitory rooms, condominiums, apartments, and similar living units.

Compartment – A compartment is a space completely enclosed by walls and a ceiling. The compartment enclosure is permitted to have openings (in walls) to an adjoining space, provided that soffits or lintels along the ceiling over the compartment opening has a minimum depth of 8 in. (203mm) from the ceiling. In other words, areas such as hallways, stairwells, and rooms must be separated by beams, lintels or soffits 8 or more inches in depth to be considered single compartments.

Obstructed Construction – Panel construction and other construction where beams, trusses, or other members impede heat flow or water distribution in a manner that materially affects the ability of sprinklers to control or suppress a fire. See NFPA 13 Appendix for detailed explanations of this type of construction.

Unobstructed Construction – Construction where beams, trusses, or other members do not impede heat flow or water distribution in a manner that materially affects the ability of sprinklers to control or suppress a fire. This type of construction has the following features: (1) horizontal structural members that are not solid; (2) openings of the structural members are at least 70% of the cross sectional area; (3) depth of the structural members do not exceed the least dimension of the openings; or (4) the spacing of structural members exceeds 7.5

feet on center. See NFPA 13 Appendix for detailed explanations of this type of construction.

Flat Ceiling – A continuous ceiling in a single plane.

Smooth Ceiling – A continuous ceiling free from significant irregularities, lumps or indentations.

Horizontal Ceiling – A ceiling that does not exceed a slope of 2/12 pitch (slope of 16.7% or 9.4°).

Sloped Ceiling – A ceiling exceeding a maximum slope of 2/12 (9.4°) pitch.

Installation Considerations

Residential sprinklers utilizing a glass bulb thermal element have orange protective caps and straps to provide temporary protection to the fragile glass bulb during shipping and installation.

- a. Do not install any bulb type sprinkler if the bulb is cracked or there is liquid missing from the bulb. While holding the sprinkler in the horizontal position, a small air bubble having an approximate diameter of 1/16" should be visible.
- b. The sprinkler is designed for installation with the protective strap in place using the appropriate sprinkler wrench.
- c. Sprinklers that are dropped during the installation process or that are installed on piping other than that in accordance with Item "a" shall be replaced, including sprinklers with protective caps or straps.
- d. Protective caps and straps shall be removed only using means in accordance with the manufacturer's installation instructions. They are not to be left on the sprinkler after the sprinkler system is placed in service.
- e. Protective caps and straps shall be removed only when water supply is made available to the sprinkler for the purposes of fire protection and placed in service.
- f. A leak-tight 1/2" NPT sprinkler joint should be obtained with a maximum torque of 14 ft-lbs to 21 ft-lbs. (approximately 2 turns past hand tight. Do not over tighten). Higher levels of torque may distort the sprinkler inlet or bend the frame, causing leakage or impairment of the sprinkler.

Where applicable, escutcheon plates must be installed. Absence of an escutcheon plate, where there is an annular space between the ceiling and the sprinkler, may delay sprinkler operation in the event of a fire. Never introduce any leak stopping additives to any fire sprinkler system.

3.

Residential sprinklers must be installed with the manufacturer's specified sprinkler wrench. Channel locks, crescent wrenches or anything other than the proper sprinkler wrench shall not be used.

Installing sprinklers in CPVC and copper piping systems require special considerations. Never install the sprinkler into the reducing fitting prior to attaching the reducing fitting to the system piping. When installing residential sprinklers or commercial sprinklers in a CPVC piping system, sprinklers must be installed only after the reducing fitting has been installed and the CPVC manufacturer's setting time for the primer and/or cement has passed. This is to ensure that the cement does not accumulate within the sprinkler. In copper piping systems, sprinklers must be installed only after the inside of the sprinkler drop and associated fittings have been wire-brushed to remove any residual flux. Residual flux can cause corrosion. Both of these conditions can impair and prevent proper sprinkler operation.

System Design Criteria

Permitted Sprinklers for Residential Sprinkler Systems

For NFPA 13D and 13R sprinkler systems, only listed residential sprinklers shall be used, with the following exceptions:

1. Listed standard dry-pendent or dry sidewall sprinklers shall be permitted to be extended into unheated areas not intended for living purposes.
2. Quick-response sprinklers shall be permitted to be used in mechanical closets.
3. For NFPA 13R systems, listed quick-response sprinklers shall be permitted to be installed in dwelling units meeting the definition of a compartment where no more than four (4) sprinklers are located within the dwelling unit.

Non-residential sprinklers are to be installed in accordance with the criteria specified by NFPA 13.

Residential Sprinkler Positioning and Spacing Requirements

When locating residential sprinklers, consideration must be given to sensitivity, sprinkler spacing, obstructions to discharge, temperature rating, and proximity to heat sources.

Sprinkler Sensitivity - Deflector Positioning

Residential pendant sprinklers not listed with specific positioning criteria must be positioned so that the deflector is within 1 in. to 4 in. (25.4 mm to 102 mm) from the ceiling. On flat, horizontal ceilings, Reliable Model F1 Res 49 pendent and recessed pendant sprinklers may also be positioned with the deflector 4" to 8" (102 mm to 203 mm) from the ceiling, in accordance with the listed flows and pressures shown in Bulletin 135. If located in

closets, it is permitted to install pendant sprinklers so that the deflector is within 12 inches (305 mm) of the ceiling. Residential sidewall sprinklers that have not been listed with specific positioning criteria must be positioned so that the deflectors are within 4 in. to 6 in. (102 mm to 152 mm) from the ceiling. Install sidewall sprinklers having listed positioning criteria in accordance with their listing. Under both horizontal and sloped ceilings, always align sprinkler deflectors so that the deflector is parallel with the plane of the ceiling surface.

Sprinkler Spacing Under Horizontal Ceilings

Several maximum coverage areas are used for residential sprinklers in accordance with minimum listed flows and pressures. The area of coverage must be equal to or greater than both the length and width of the hazard area. Residential sprinklers must be located not more than half the listed spacing nor less than 4" (102 mm) from walls. Adjacent sprinklers must be located no farther apart than the listed spacing; the minimum distance to prevent cold soldering, unless otherwise specified, is 8 feet (2.44 m).

When selecting an area of coverage, the suggested practice is to select one that can be adequately supplied by the available water supply, allowing for the installation of as few sprinklers as possible while observing all guidelines pertaining to obstructions and spacing. After selection of an area of coverage, sprinklers must be spaced according to the criteria set forth in the NFPA standards and this document.

Sprinkler Spacing Under Sloped Ceilings

For installation under sloped ceilings, several maximum coverage areas are also provided, but at different minimum flows and pressures than those for horizontal ceilings. The spacing of sprinklers is measured along the slope when determining the distance of walls and between sprinklers. Residential sprinklers may be located no more than 1/2 the listed spacing nor less than 4" (102 mm) from the peak of the sloped ceiling. Residential sprinklers located at the highest elevation must not be located more than 3 feet (0.9 m) measured vertically down from the peak. Refer to Reliable Bulletin 025 for listed coverage areas, flow and pressure requirements, and positioning criteria for residential sprinklers installed under sloped ceilings.

Obstruction to Water Distribution

Refer to Figures 1 through 13 for the location of sprinklers relative to obstructions. The discharge from residential sprinklers is directed radially outward and downward from the sprinkler. Sprinklers must be located such that there will not be any spaces shielded from distribution by walls, dividing partitions, or other dwell-

4.

ing construction features. If the sprinkler water distribution pattern is obstructed, the obstruction is to be considered the maximum distance of coverage for a given sprinkler. Additional sprinklers beyond the obstruction may be necessary unless the obstruction criteria contained herein can be met. Consult the appropriate NFPA standard and/or the AHJ for guidance regarding these situations.

Reliable flat plate concealed sprinklers, the Models RFC30 (301L), RFC43 (431L), RFC49 (491L) and RFC56, utilize a drop-down style deflector. The distance the deflector drops below the ceiling is needed when determining the position of the deflector above the bottom of an obstruction. These distances are as follows:

- Nonadjusted (cover plate flush to cup) - $\frac{1}{8}$ " (2mm)
- Adjusted (cover plate flush to cup) - $\frac{1}{8}$ " (2mm)

Continuous and Noncontinuous Obstructions

A minimum distance is required to be maintained between sprinklers and continuous obstructions, such as beams, soffits, and long horizontal light fixtures. See Figures 1, 2, 4, 5, 6, 7 and/or 13.

A minimum distance is also required to be maintained between sprinklers and noncontinuous obstructions, such as ceiling fans and certain light fixtures. The ceiling fan motor housing is the primary element that can obstruct the sprinkler discharge pattern. Testing has demonstrated that no adverse effects occur as a result of the ceiling fan's blade rotation in either direction.

With regards to location of sprinklers near light fixtures, there are two considerations: the amount of heat the light gives off and the light fixture as an obstruction. The minimum distance of a sprinkler relative to the light as a heat source is given in Table B. If the light is also an obstruction, then the obstruction criteria must be applied.

Table B – Minimum Distances for Ordinary and Intermediate Residential Sprinklers Relative to Specific Heat Sources

Heat Source	Minimum Distance from Edge of Source to Ordinary Temperature Sprinkler (135°F or 155°F)		Minimum Distance from Edge of Source to Intermediate Temperature Sprinkler (175°F)	
	In. (mm)	ft. (m)	In. (mm)	ft. (m)
Side of open or recessed fireplace	36 (914)	3 (0.91)	12 (305)	1 (0.30)
Front of recessed fireplace	60 (1524)	5 (1.52)	36 (914)	3 (0.91)
Coal or wood burning stove	42 (1067)	3 (0.91)	12 (305)	1 (0.30)
Kitchen range	18 (457)	1 (0.30)	9 (229)	0.7 (0.23)
Wall oven	18 (457)	1 (0.30)	9 (229)	0.7 (0.23)
Hold air flues	18 (457)	1 (0.30)	9 (229)	0.7 (0.23)
Uninsulated hot water pipes	12 (305)	1 (0.30)	6 (152)	0.5 (0.15)
Side of ceiling or wall-mounted hot air diffusers	24 (607)	2 (0.61)	12 (305)	1 (0.30)
Front of wall-mounted hot air diffusers	36 (914)	3 (0.91)	18 (457)	1.5 (0.46)
Hot water heater or furnace	6 (152)	0.5 (0.15)	3 (76)	0.2 (0.06)
Light Fixture 0.11 - 250 W	6 (152)	0.5 (0.15)	3 (76)	0.2 (0.06)
250 W - 450 W	12 (305)	1 (0.30)	6 (152)	0.5 (0.15)

relative to the minimum distance required from Table B. For noncontinuous obstructions, apply the "four times rule" as provided in NFPA 13 where it is determined that the sprinkler can spray to at least two sides of the obstruction, either over and under or around the obstruction on both sides. Sprinklers shall be positioned away from the obstruction a minimum distance of four times the maximum dimension of the obstruction. The maximum clear distance required shall be 36" (914mm).

Temperature Ratings

Ordinary temperature rated sprinklers (135°F [57°C] - 155°F [57°C]) are only permitted for installation where the maximum ambient ceiling temperature will not exceed 100°F (38°C). Where ambient ceiling temperatures are expected to exceed 100°F (38°C), use intermediate temperature-rated residential sprinklers (175°F [79°C]), which can be exposed to a maximum ambient temperature of 150°F (66°C). The following practices apply, unless higher expected ambient temperatures require a higher temperature rated sprinkler:

1. Sprinklers under glass or plastic skylights exposed to direct rays of the sun shall be of the intermediate temperature classification.
2. Sprinklers in an unventilated concealed space under insulated roof or in an unventilated attic shall be of the intermediate temperature classification.
3. Residential sprinklers must be located so as to prevent inadvertent operation due to exposure to normal heat sources. Sprinklers must be positioned a sufficient distance away from heat sources such as fireplaces, ovens, kitchen ranges, hot water pipes, water heaters, furnaces and associated duct work, and light fixtures. The following minimum distances in accordance with NFPA 13D and 13R must be maintained as indicated in Table B.

Hydraulic Design Requirements

Reliable residential sprinkler listings indicate minimum flow rates for each specified coverage area. Hydraulic calculations are required to verify adequate water supply at the hydraulically most remote single sprinkler operation. Where a compartment has more than one sprinkler, multiple sprinkler calculations are required, and each sprinkler must be calculated flowing identical minimum flow rates. No reduction in minimum flow requirements is provided for flowing multiple sprinklers. More design sprinklers may need to be calculated than the minimum stated by the NFPA standards where unusual conditions may result in more sprinklers operating. These conditions include sloped ceilings having a pitch greater than 8/12 (33.7°) or beamed ceilings qualifying as obstructed construction, as defined by NFPA 13. Consult with the AHJ regarding the number of "design sprinklers" for these types of applications.

NFPA 13D.

The number of design sprinklers under flat, smooth, horizontal ceilings shall include all sprinklers within a compartment, up to a maximum of two (2) sprinklers that requires the greatest hydraulic demand. The cULus Listed specific coverage criteria for systems designed to NFPA 13R are given in the technical bulletins referenced in Table A, as a function of the maximum allowable coverage area and temperature rating. For actual coverage areas less than or between those indicated in the respective bulletin, it is necessary to use the minimum required flow for the next largest area, as shown above.

For example, assuming the use of a pendant sprinkler, for an actual coverage area of 12 ft. x 14 ft. (3.7 m x 4.2 m), the specific coverage criteria for a 14 ft. x 14 ft. (4.2 m x 4.2 m) coverage area must be used. For an actual coverage area of 15 ft. x 15 ft. (4.6 m x 4.6 m), the specific coverage criteria for a 16 ft. x 16 ft. (4.9 m x 4.9 m) coverage area must be used.

NFPA 13R

The number of design sprinklers under flat, smooth, horizontal ceilings shall include all sprinklers within a compartment, up to a maximum of four (4) sprinklers, that requires the greatest hydraulic demand. The cULus Listed specific coverage criteria for systems designed to NFPA 13R are given in the technical bulletins referenced in Table A, as a function of the maximum allowable coverage area and temperature rating. For actual coverage areas less than or between those indicated in the respective bulletin, it is necessary to use the minimum required flow for the next largest area, as shown above.

NFPA 13

For residential sprinkler systems designed to NFPA 13, a minimum density of 0.1 gpm/ft² must be provided over the "design area" that includes the four (4) hydraulically most demanding sprinklers for the actual coverage areas being protected by the 4 sprinklers. The minimum required discharge from each of the four most hydraulically demanding sprinklers shall be the greater of the following:

1. The flow rates given in the Reliable Residential Sprinkler Technical Bulletins referenced in Table A for NFPA 13D and 13R as a function of temperature rating and maximum allowable coverage area (for actual coverage areas less than or between those indicated in the respective technical bulletin, it is required to use the minimum required flow for the next largest coverage area); or
2. A minimum discharge density of 0.1 gpm/ft² applied over the "design area" consisting of the four most hydraulically demanding sprinklers for the actual coverage areas being protected by the four sprinklers. The maximum dimension of the actual coverage area cannot be any greater than the maximum coverage area indicated in the technical bulletins referenced in Table A.

Design Note: Using the $A_s = S \times L$ method to determine the sprinkler protection area of coverage in accordance with NFPA 13, apply the 0.1 gpm/ft² density to this area to determine the minimum required flow. Compare this flow to the minimum 0.05 gpm/ft² cULus Listed flow for the appropriate coverage area in the technical bulletin for the specific residential sprinkler. If the flow stated in the technical bulletin is less than the calculated 0.1 gpm/ft² density flow required, the .1 density flow must then be used in the equation $Q = K \sqrt{P}$, solving for P, to establish the minimum required pressure using the sprinkler K-factor. **Note:** In many cases the listed flow of individual residential sprinklers may exceed the required minimum 0.05 gpm/ft² density. Reliable has available residential sprinklers with larger K-factors (K=5.6 and K=5.8) that will provide lower pressure demands for 0.1 gpm/ft² densities in NFPA 13 residential applications.

Example No. 1

If a room is 12 ft wide x 20 ft long (3.6 m x 6.1 m), the coverage area being considered would be 240 ft² (22.3 m²). Using an F1 Res-49 pendant sprinkler (1"-4" ceiling-to-deflector distance), the flow for a 20 ft x 20 ft (6.1 m x 6.1 m) coverage area is 20 gpm @ 16.7 psi (7.57 L/min @ 1.14 bar). However, based on a discharge density of 0.1 gpm/ft², the flow rate required would be 24 gpm (90.8 L). Therefore, 24 gpm (90.8 L/min) would be the minimum flow required for each design sprinkler. The corresponding pressure would be 24 psi (1.65 bar).

Example No. 2
 If a room is 10 ft wide x 20 ft long (3.0 m x 6.1 m), the coverage area being considered would be 200 ft² (18.6 m²). Using an F-1 Res 58 pendant sprinkler (1'-4" ceiling-to-deflector distance), the flow for a 20 ft x 20 ft (6.1 m x 6.1 m) coverage area is 22 gpm @ 14.4 psi (83.3 L/min @ 0.99 bar). Based on a discharge density of 0.1 gpm/ft², the flow rate required would only be 20 gpm (75.7 L/min). However, the flow of 22 gpm must still be used as the minimum flow for each design sprinkler, since this is the minimum cULus Listed flow for this sprinkler at the 20 ft x 20 ft coverage area.

Example No. 3
 For a situation where the coverage area per sprinkler is 16 ft x 8 ft (4.9 m x 2.4 m), or 128 ft² (11.9 m²), the F-1 Res 44 HSW, having a temperature rating of 155°F (69°C) and positioned 4" to 6" (101 mm to 152 mm) below the ceiling, requires a minimum flow of 16 gpm @ 13.3 psi (60.6 L/min @ .92 bar) for a 16 ft x 8 ft (4.9 m x 2.4 m) coverage area. Based on a minimum discharge of 0.1 gpm/ft², the flow rate needed would only be 12.8 gpm @ 10.2 psi (46.4 L/min @ 0.7 bar). However, the flow rate of 16 gpm (60.6 L/min) must still be used for each design sprinkler.

Sloped Ceilings
 Specific UL Listed flows, pressures and coverage areas for sloped ceilings are provided in Reliable Bulletin 035. Refer to this bulletin for hydraulic design requirements. The number of design sprinklers is the same as that specified for horizontal ceilings, with the exception of the Model F-Ras 44 HSW. This sprinkler requires a minimum 3 sprinkler design in a compartment when discharging across the slope, as specified in Bulletin 035.
 For systems designed to NFPA 13, 13D or 13R, where specific cULus Listed flows for sloped ceilings are not required, consult with the AHJ regarding the number of "design sprinklers" for sloped ceilings having a pitch greater than 2 in 12 (9.4%).
 cULus Listed flows and pressures do not exist for sloped ceilings having a pitch greater than 8/12 (33.7%). Again, consult with the AHJ regarding the number of "design sprinklers" for these types of applications. Listed areas of coverage must correspond to ceiling slope, and spacing of sprinklers under sloped ceilings is measured along the slope when determining distance off of walls and between sprinklers.

Care and Maintenance

It is recommended that automatic sprinkler systems be inspected and maintained in accordance with the criteria set forth in NFPA 25, Inspection, Testing and Maintenance of Water-Based Fire Protection Systems by a qualified inspection service.
 Do not clean the sprinklers with soap and water, detergents, ammonia, or any other cleaning fluid. Remove dust by using a soft brush or leather duster, or by gentle vacuuming with a soft bristle brush.
 Any sprinklers that have operated, been damaged or been painted outside of the factory shall be replaced with a new sprinkler. The new sprinkler shall have the same performance characteristics as the original sprinkler; that is, the same temperature rating, nominal K-factor, coverage area, and the same or lower flow rate requirements.
 Wet-pipe sprinkler systems must be maintained at a minimum temperature of 40°F (4°C). Exposure to freezing temperatures can damage system piping and residential sprinklers.
 Do not hang anything from sprinklers or sprinkler piping. Do not put curtains, drapes or valances around sprinklers. Doing so will obstruct the discharge pattern of the sprinkler.

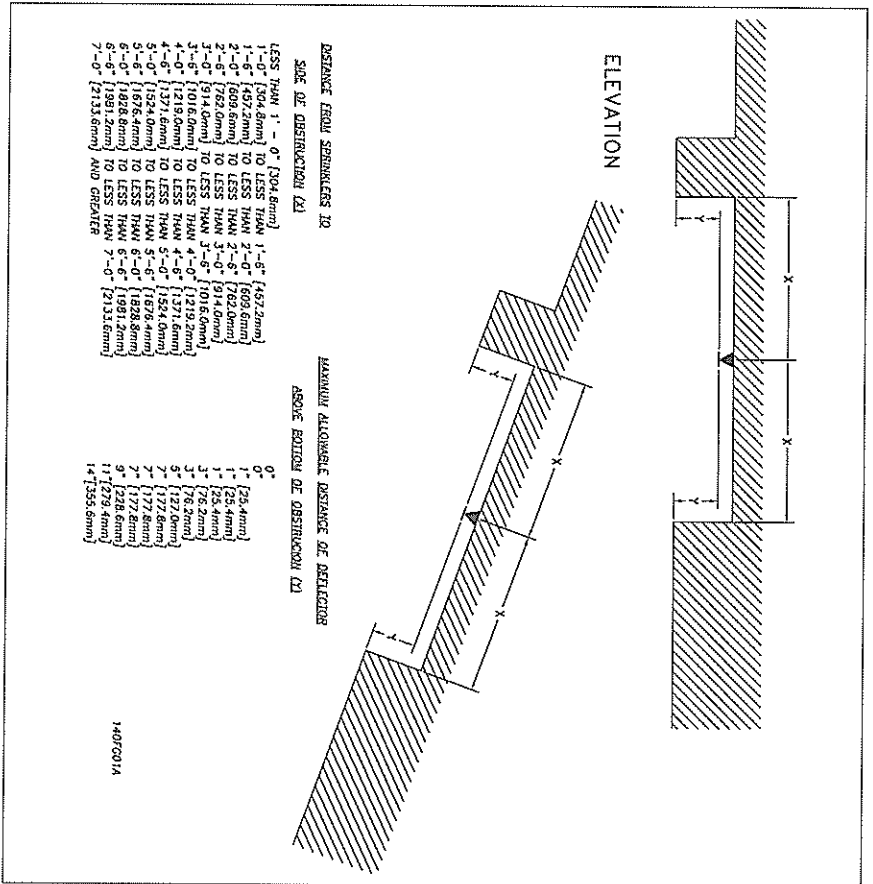

Figure 1 Position of sprinklers to avoid obstructions to discharge radially from pendant sprinklers.

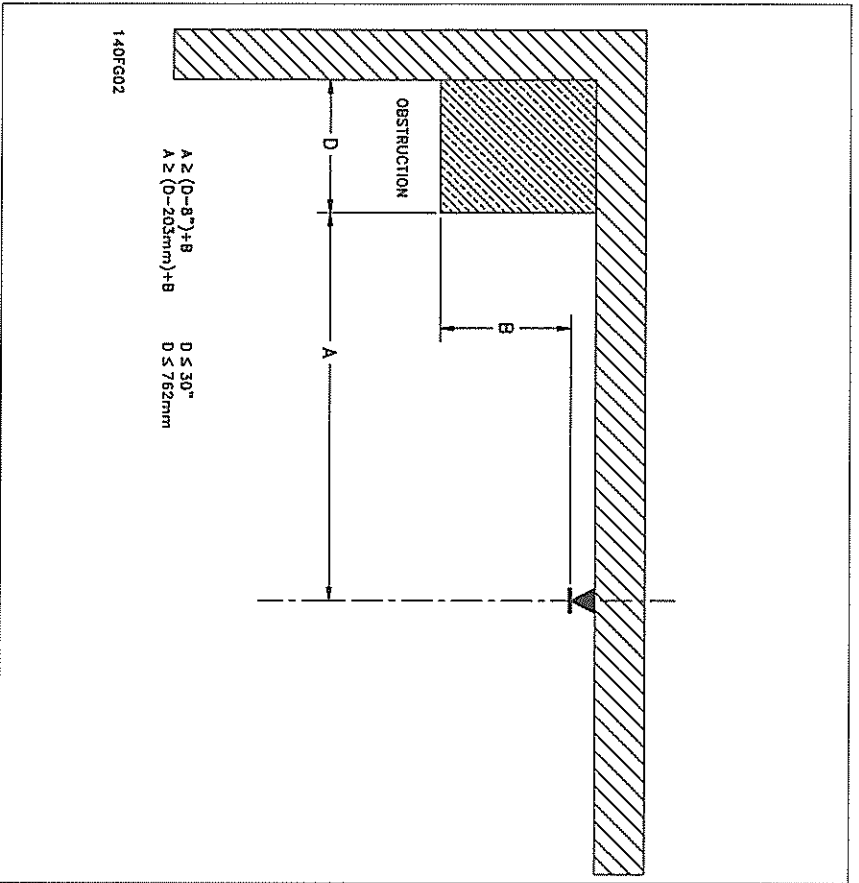

Figure 2
Positioning of pendant type sprinklers relative to obstructions against walls.

9.

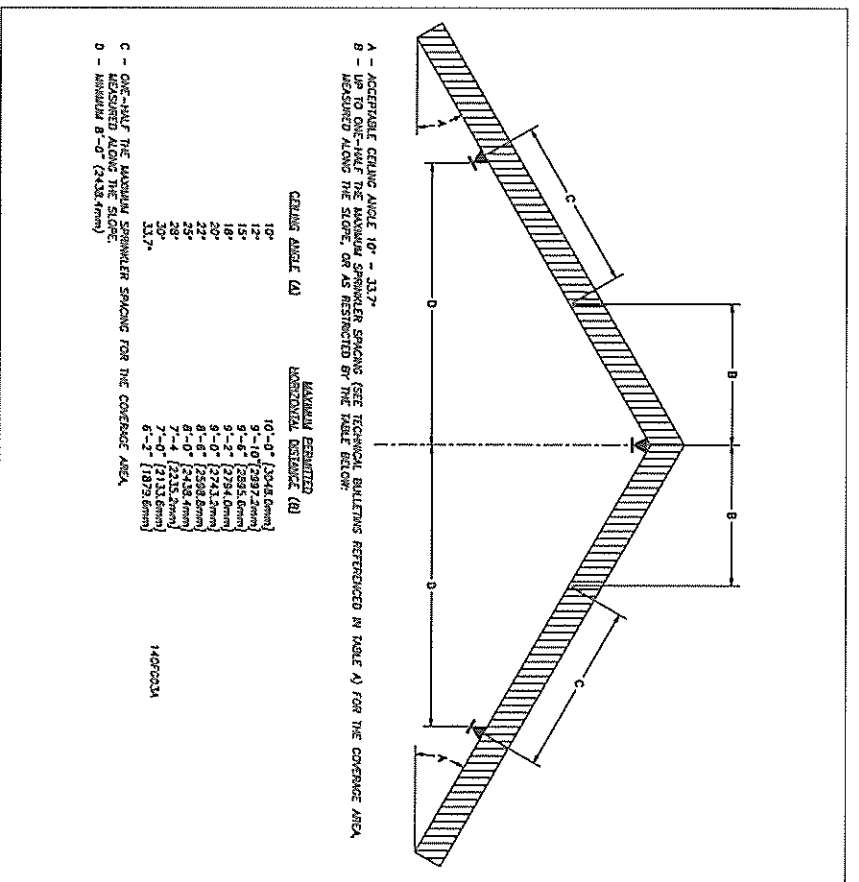

Figure 3
Sprinkler spacing for pendant sprinklers located at the peak.

10.

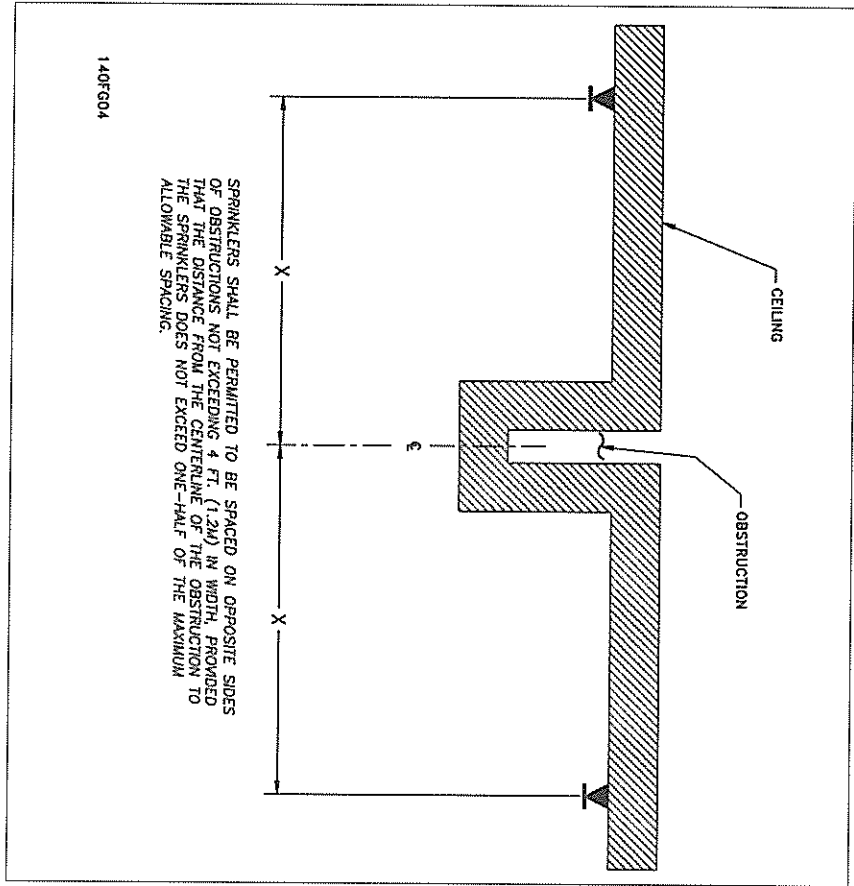

Figure 4
Positioning of pendent sprinklers relative to continuous obstructions at the ceiling.

11.

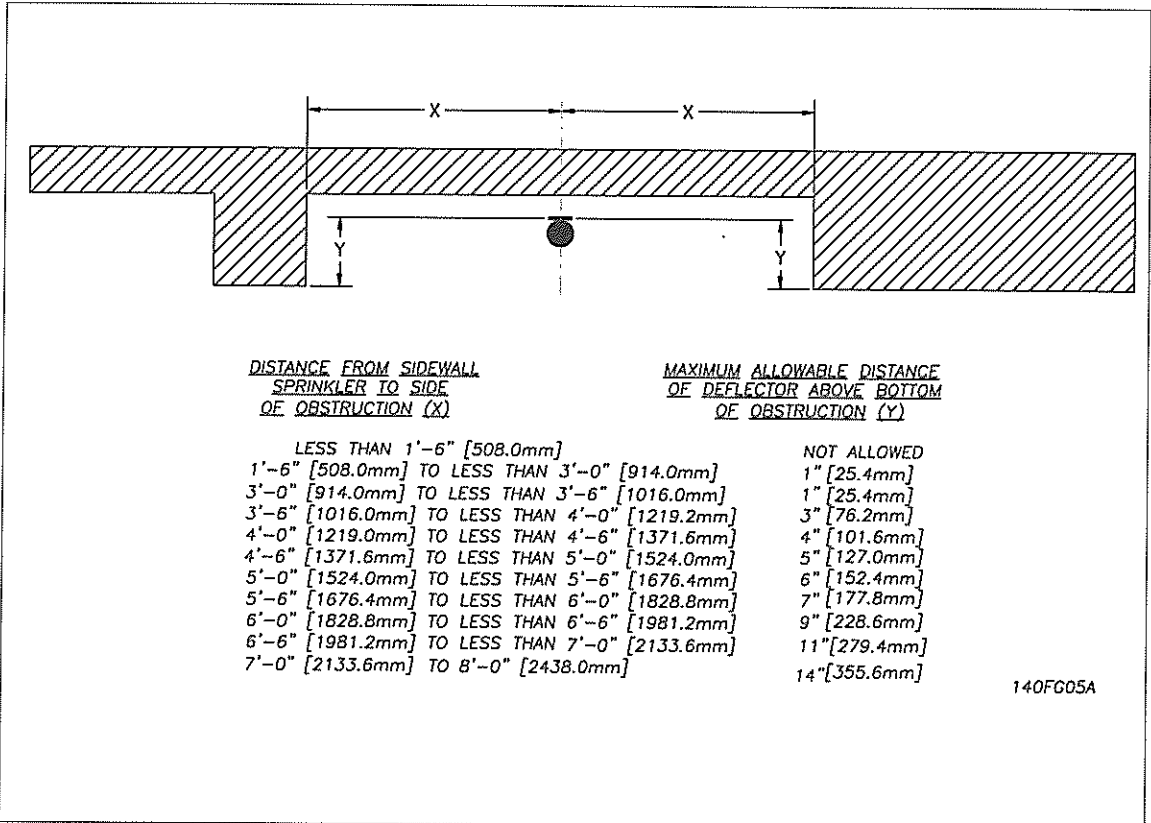

Figure 5
Positioning of sidewall sprinklers to avoid obstructions along the wall.

12.

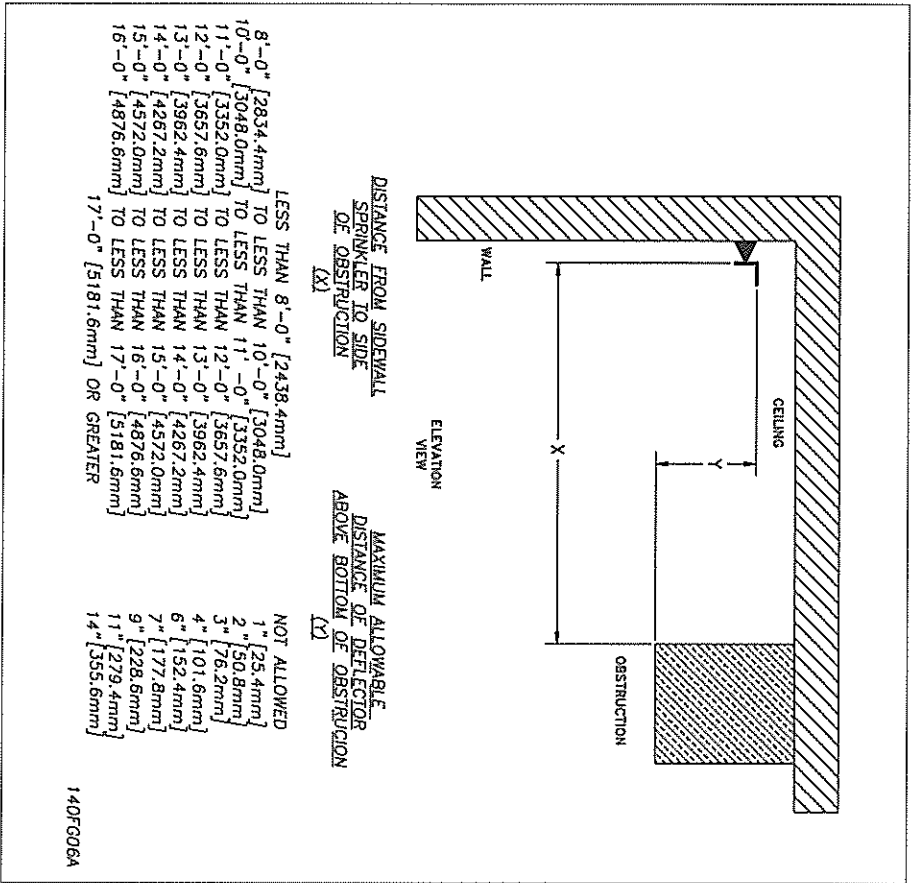

Figure 6
Positioning of sidewall sprinklers to avoid obstructions.

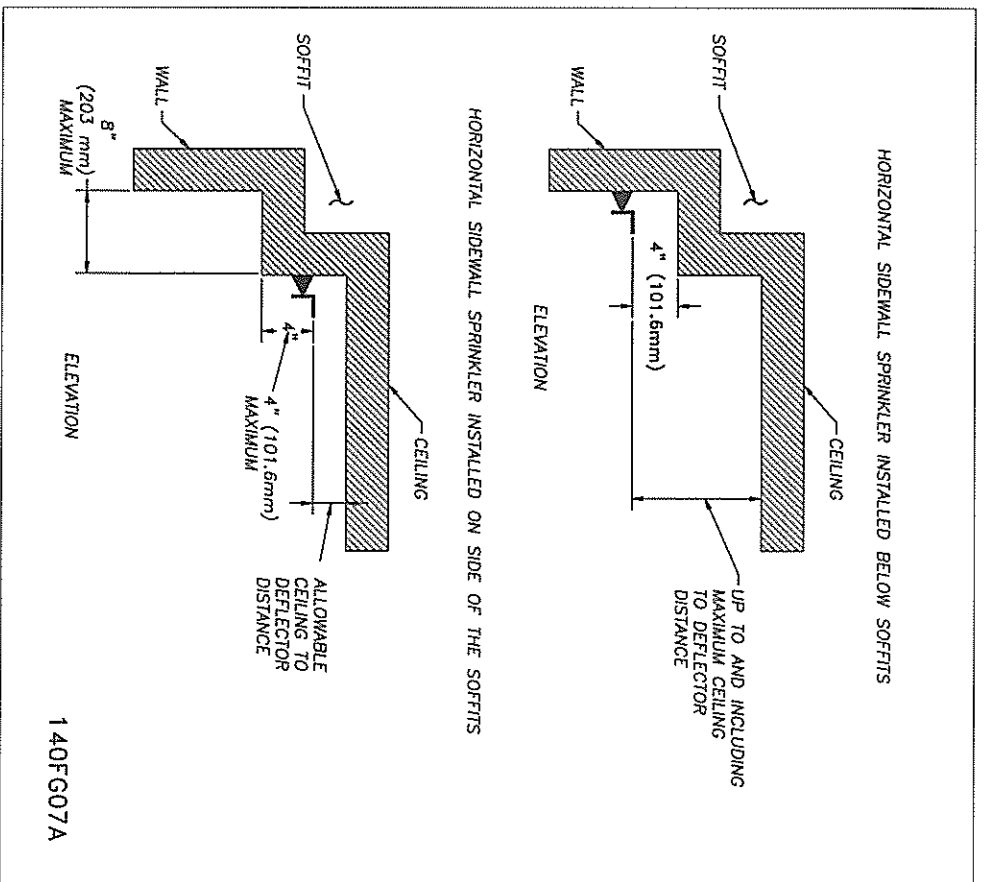

Figure 7
Positioning of HSW sprinklers relative to continuous obstructions along a wall.

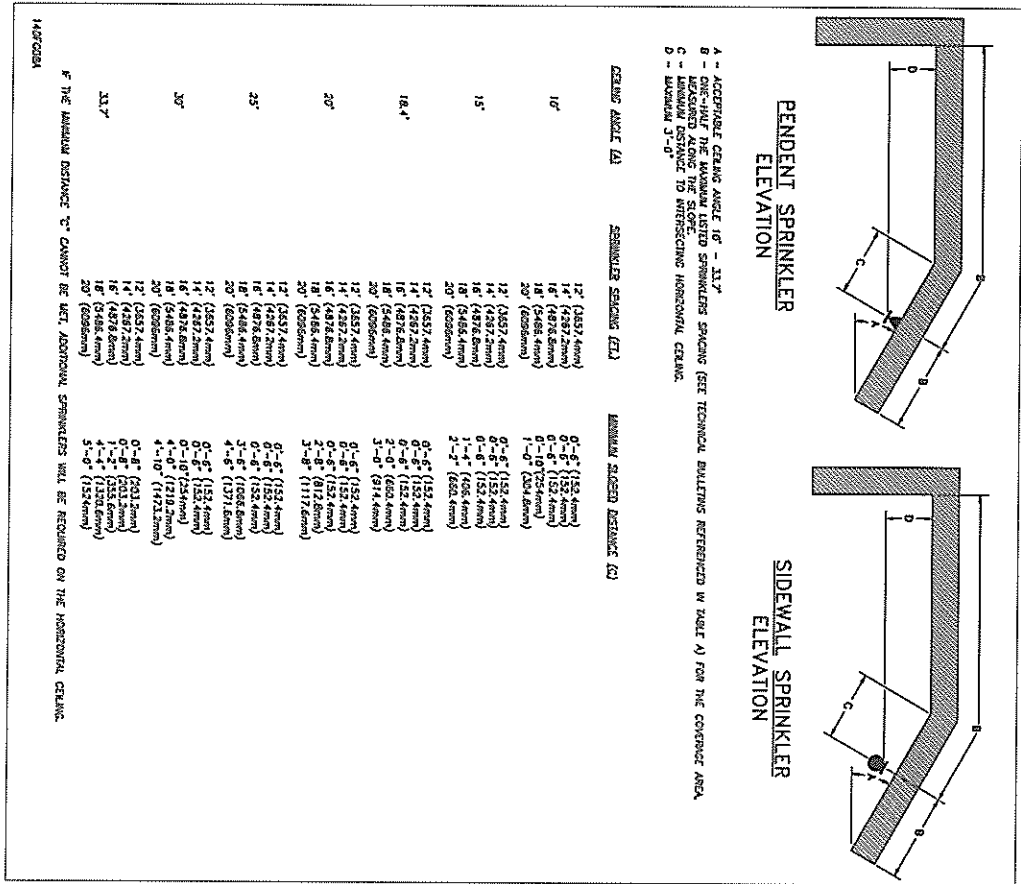

Figure 8
Obstruction to discharge by intersecting horizontal ceiling

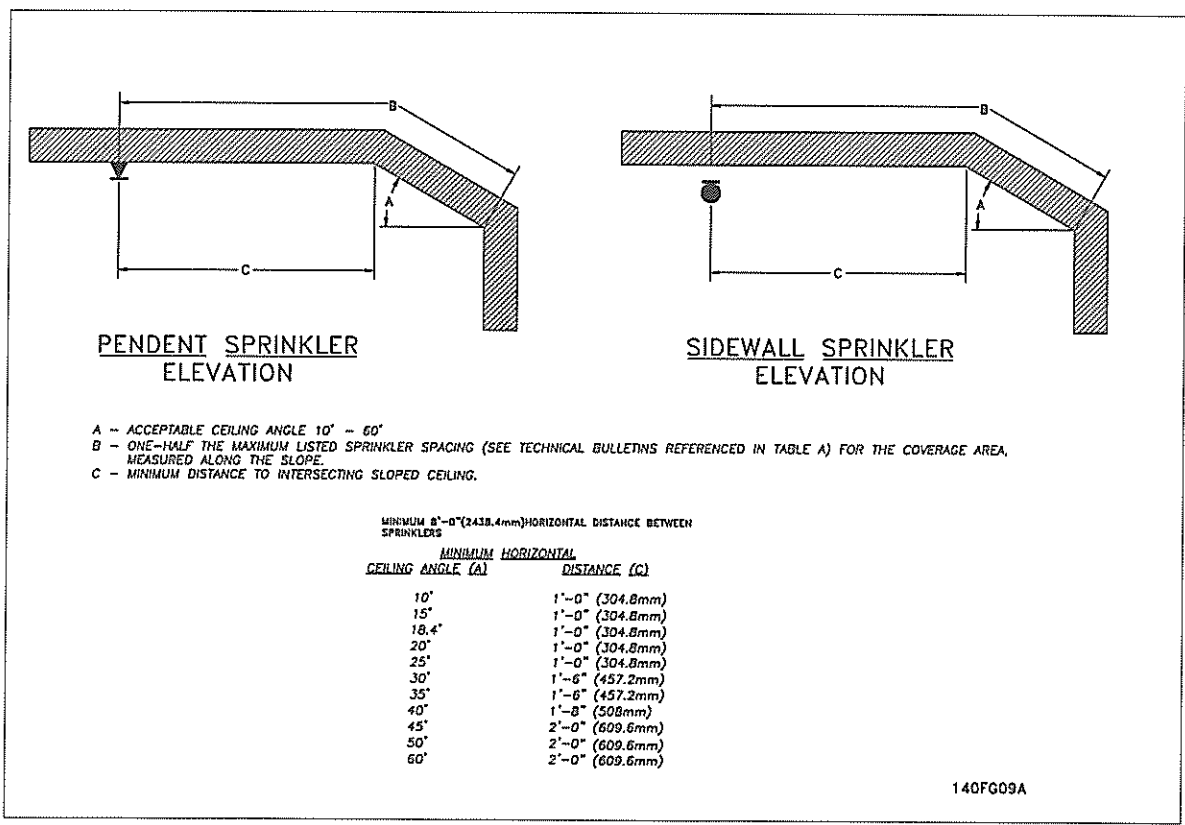

Figure 9
Obstruction to discharge by intersecting sloped ceiling.

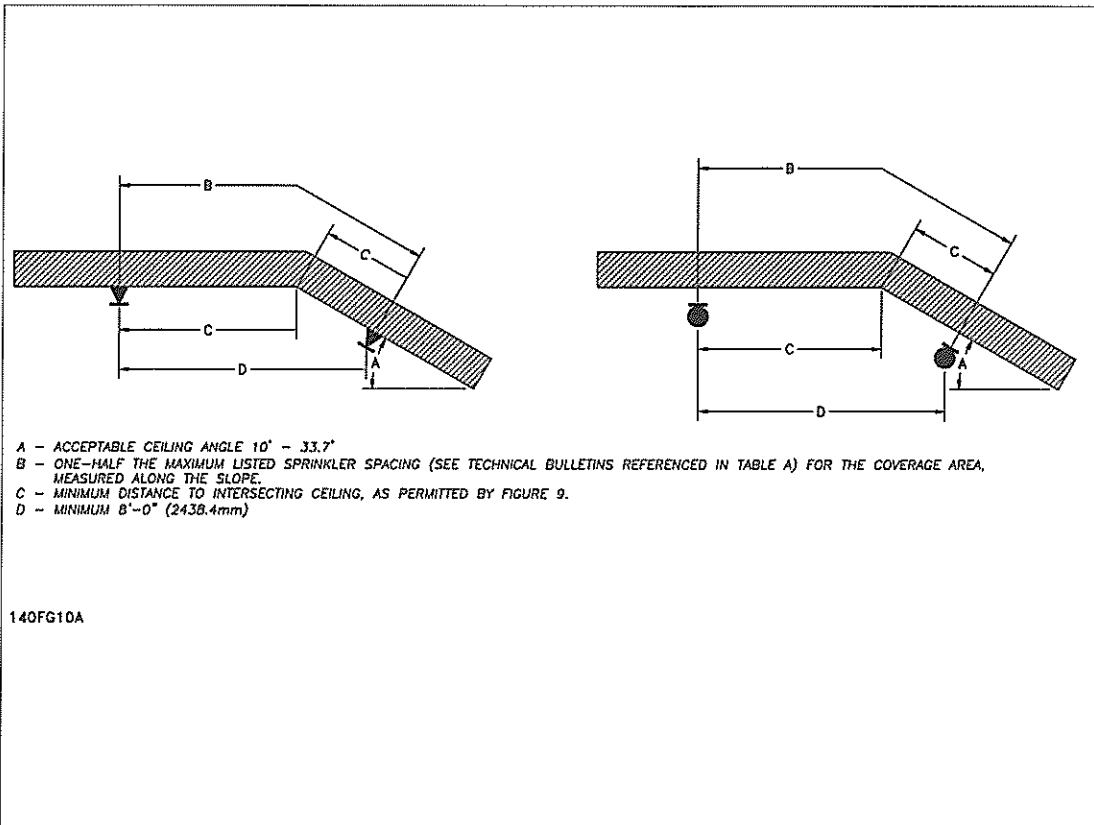

Figure 10
 Minimum distance between sprinklers on intersecting ceilings.

17.

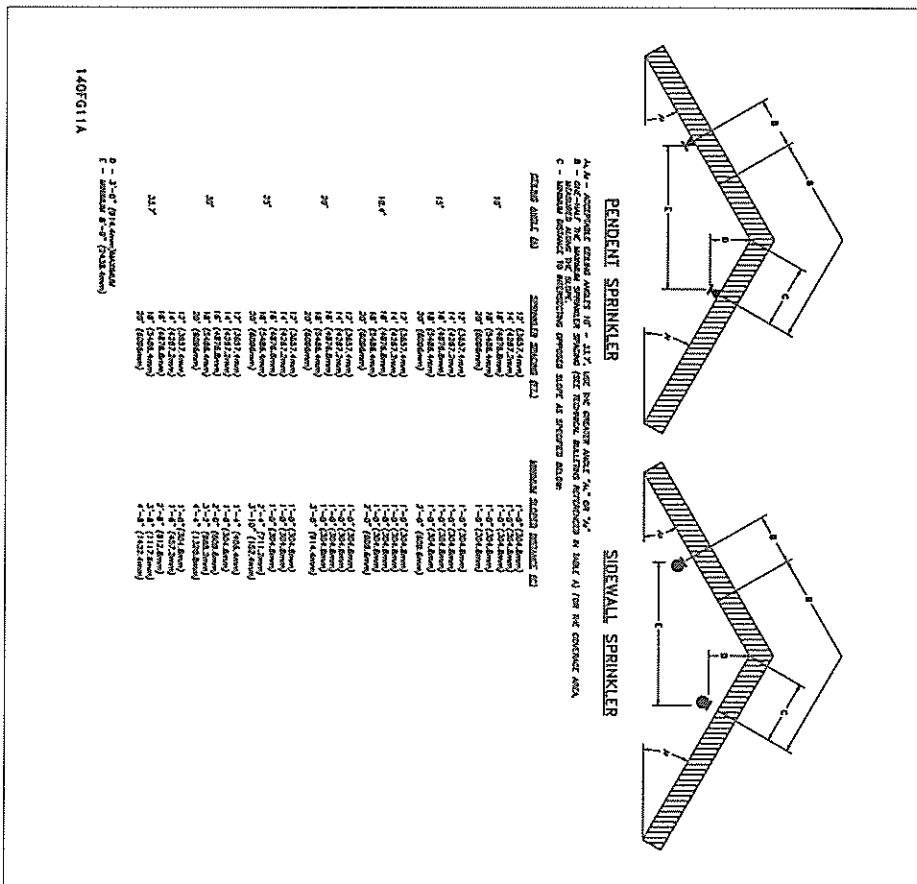

Figure 11
 Non-symmetric sprinkler locations on opposing slopes.

18.

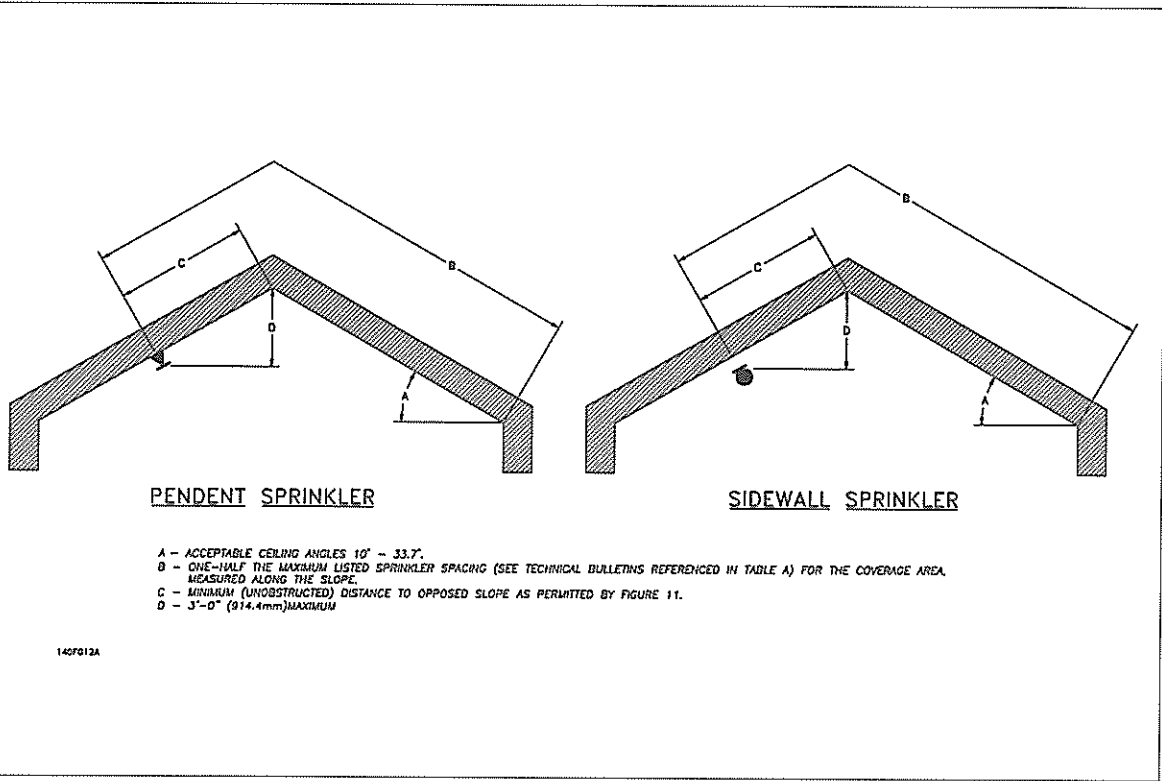

Figure 12
Single sprinkler coverage criteria for cathedral ceilings.



The Reliable Automatic Sprinkler Co., Inc.
 (800) 431-1389 Sales Offices
 (800) 848-6051 Sales Fax
 (914) 829-2042 Corporate Offices
 www.reliable sprinkler.com Internet Address

Recycled Paper
 Revision lines indicate updates or new data
 EG, Printed in U.S.A. 02/11 P/N 293970031

The equipment presented in this bulletin is to be installed in accordance with the latest published Standards of the National Fire Protection Association, Factory Mutual Research Corporation, or other similar organizations and also with the provisions of governmental codes or ordinances whenever applicable. Products manufactured and distributed by Reliable have been producing life and property for over 90 years, and are installed and serviced by the most highly qualified and reputable sprinkler contractors located throughout the United States, Canada and foreign countries.

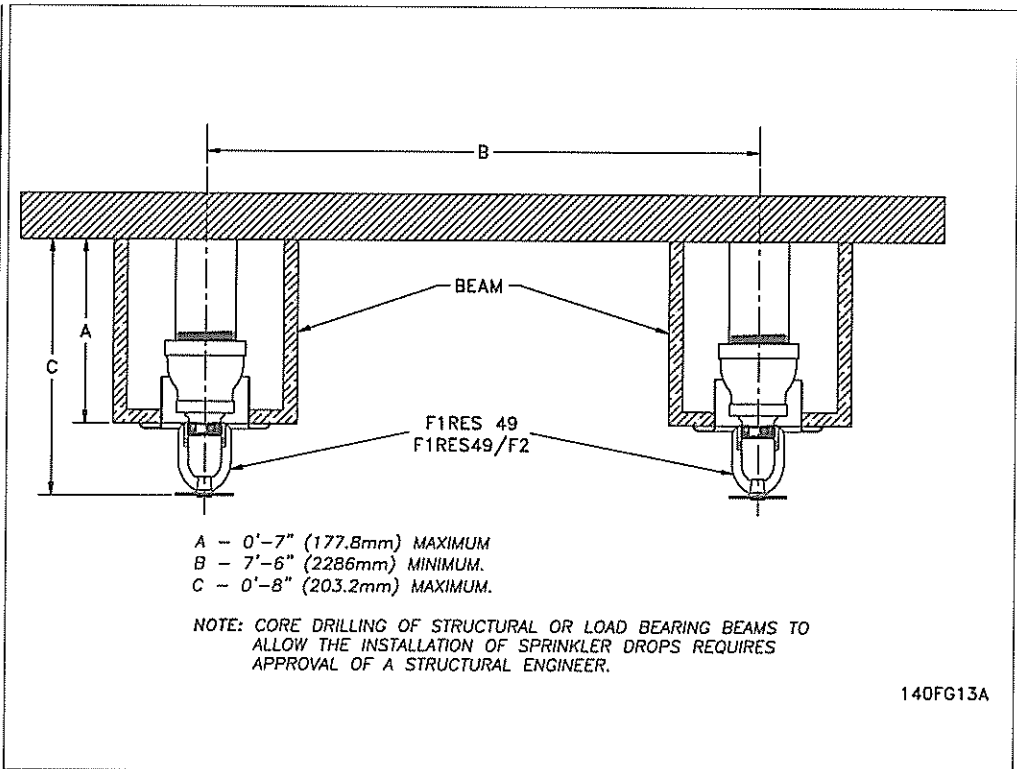

Figure 13
Pendant sprinkler positioning for beamed ceiling.

Reliable®

Model RFC30 (SIN RA0611)
 Model RFC43 (SIN RA0612)
 Model RFC49 (SIN RA0616)
 Residential Flat Concealed
 Sprinklers

A Residential Flat Concealed Sprinkler engineered for a minimum design density of 0.05 gpm/ft² with low GPM requirements.

Features

1. Very low water flow requirements.
2. ½" (13mm) Total adjustment.
3. Thread-On/Thread-Off or Push-On/Thread Off cover attachment option.
4. Smooth aesthetic ceiling profile.
5. Available in brass, chrome and black plated or painted finishes.

Listings & Approval

1. Listed by Underwriters Laboratories, and certified by UL for Canada (cULus)
2. NYC MEA 258-93-E

UL Listing Categories

Residential Automatic Sprinklers

UL Guide Number

VKKW

Product Description

Model RFC30, RFC43 and RFC49 Concealed Residential Sprinklers are fast response residential fusible solder link automatic sprinklers. Residential sprinklers differ from standard sprinklers primarily in their response time and water distribution patterns.

Model RFC30, RFC43 and RFC49 sprinklers discharge water in a hemispherical pattern below the sprinkler deflector. Residential distribution patterns are higher and generally contain a finer droplet size than standard sprinkler patterns.

The combination of speed of operation and high discharge pattern required for residential sprinklers has demonstrated, in fire testing, an ability for controlling residential fires, and thereby providing significant evacuation time for occupants.

The RFC30, RFC43 and RFC49 Sprinklers provide the best form of fire protection by combining an attractive appearance and ½" (13mm) of cover adjustment for ease of installation. The small diameter cover plate is easily and positively attached and blends into the ceiling, concealing



the most dependable fire protection available, an automatic sprinkler system.

The RFC30, RFC43 and RFC49 are UL Listed Residential Sprinklers to be installed in the residential portions of any occupancy in accordance with NFPA 13, 13R, & 13D.

The RFC30, RFC43 and RFC49 can reduce the need for precise cutting of drop nipples. The threaded cover plate assembly can be adjusted without tools to fit accurately against the ceiling. The fire protection system need not be shut down to adjust or remove the cover plate assembly.

Application and Installation

The RFC30, RFC43 and RFC49, for residential installations, use a 165°F (74°C) fusible solder link in a tuning fork style sprinkler frame with a drop-down deflector. This assembly is recessed into the ceiling and concealed by a flat cover plate. The cover plate is attached to the skirt, using 135°F (57°C) ordinary temperature classification solder. When the ceiling temperature rises, the solder holding the cover plate releases the cover allowing the deflector to drop into position and exposing the sprinkler inside to

ceiling temperature. The subsequent operation of the solder link opens the waterway and causes the deflector to drop into position to distribute the discharging water in a hemispherical pattern below the sprinkler deflector. Any adjustment of thread engagement between the cover plate and cup will assure that the drop-down deflector is properly located below the ceiling. The residential distribution pattern contains a finer droplet size than a standard sprinkler, and the pattern produces significantly higher wall wetting.

After a 2⁵/₈ inch diameter hole is cut in the ceiling, the sprinkler is to be installed with the Model FC Wrench. When installing a sprinkler, the wrench is first positioned into the sprinkler/cup assembly and around the hexagonal body of the sprinkler frame. The Wrench must bottom out against the cup in order to ensure proper, safe installation. The sprinkler is then tightened into the pipe fitting. When inserting or removing the wrench from the sprinkler/cup assembly, care should be taken to prevent damage to the sprinkler. **DO NOT WRENCH ON ANY OTHER PART**

OF THE SPRINKLER/CUP ASSEMBLY. MODEL RFC30, RFC43 AND RFC49 CONCEALED SPRINKLERS MUST BE INSTALLED ONLY WITH 135°F RATED COVERS.

Note: A leak tight 1/2" NPT (R1/2) sprinkler joint can be obtained with a torque of 8-18 ft-lbs (10,8 - 24,4 N-m). Do not tighten sprinklers over maximum recommended torque. It may cause leakage or impairment of the sprinklers.

Cover assemblies provide up to 1/2" (13mm) of adjustment. Turn the cover clockwise until the flange is in contact with the ceiling. For the push-on/thread-off option, the cover assembly is pushed onto the cup and final adjustment is made by turning the cover clockwise until the skirt flange makes full contact with the ceiling. Cover removal requires turning in the counter-clockwise direction.

In ceilings that have a plenum space above the sprinkler, the plenum space may have neutral or negative pressurization but must not be positively pressurized. Inspect all sprinklers after installation to ensure that the gap between the cover plate and ceiling and the 4 slots in the cup are all open and free from any air flow impediment.

Temperature Rating

Sprinkler	Cover Plate	Max. Ambient Temp.
165°F/74°C	135°F/57°C	100°F/38°C

Installation Data: RFC30 (SIN RA0611)

Thread Size inch (mm)	K Factor	Sprinkler Spacing ft. (m)	Maximum Distance to Wall ft. (m)	Minimum Distance between sprinklers ft. (m)	Minimum Required Sprinkler Discharge	
					Flow gpm (Lpm)	Press. psi (bar)
1/2" (15mm)	3.0	12 x 12 (3.6x3.6)	6 (1.83)	8 (2.43)	9 (34.1)	9.0 (0.62)
1/2" (15mm)	3.0	14 x 14 (4.3x4.3)	7 (2.13)	8 (2.43)	10 (37.8)	11 (0.76)

Note: 1 bar = 100 Kpa

Installation Data: RFC43 (SIN RA0612)

Thread Size inch (mm)	K Factor	Sprinkler Spacing ft. (m)	Maximum Distance to Wall ft. (m)	Minimum Distance between sprinklers ft. (m)	Minimum Required Sprinkler Discharge	
					Flow gpm (Lpm)	Press. psi (bar)
1/2" (15mm)	4.3	12 x 12 (3.6x3.6)	6 (1.83)	8 (2.43)	12 (45)	7.8 (0.54)
1/2" (15mm)	4.3	14 x 14 (4.3x4.3)	7 (2.13)	8 (2.43)	13 (49)	9.1 (0.63)
1/2" (15mm)	4.3	16 x 16 (4.9x4.9)	8 (2.43)	8 (2.43)	13 (49)	9.1 (0.63)
1/2" (15mm)	4.3	18 x 18 (5.5x5.5)	9 (2.74)	8 (2.43)	18 (68)	17.5 (1.21)
1/2" (15mm)	4.3	20 x 20 (6.0x6.0)	10 (3.05)	8 (2.43)	21 (79)	23.8 (1.64)

Note: 1 bar = 100 Kpa

Installation Data: RFC49 (RA0616)

Thread Size inch (mm)	K Factor	Sprinkler Spacing ft. (m)	Maximum Distance to Wall ft. (m)	Minimum Distance between sprinklers ft. (m)	Minimum Required Sprinkler Discharge	
					Flow gpm (Lpm)	Press. psi (bar)
1/2" (15mm)	4.9	12 x 12 (3.6x3.6)	6 (1.83)	8 (2.43)	13 (49)	7.0 (0.48)
1/2" (15mm)	4.9	14 x 14 (4.3x4.3)	7 (2.13)	8 (2.43)	13 (49)	7.0 (0.48)
1/2" (15mm)	4.9	16 x 16 (4.9x4.9)	8 (2.43)	8 (2.43)	13 (49)	7.0 (0.48)
1/2" (15mm)	4.9	18 x 18 (5.5x5.5)	9 (2.74)	8 (2.43)	17 (64.3)	12.0 (0.83)
1/2" (15mm)	4.9	20 x 20 (6.0x6.0)	10 (3.05)	8 (2.43)	20 (75.7)	16.7 (1.14)

Note: 1 bar = 100 Kpa

FOR SLOPED CEILING APPLICATIONS SEE RASCO BULLETIN 035.

Maintenance

Model RFC30, RFC43 and RFC49 Concealed Sprinklers should be inspected quarterly and the sprinkler system maintained in accordance with NFPA 25. Do not clean sprinklers with soap and water, ammonia or any other cleaning fluids. Remove dust by using a soft brush or gentle vacuuming. Remove any sprinkler cover plate assembly which has been painted (other than factory applied) or damaged in any way. A stock of spare sprinklers should be maintained to allow quick replacement of damaged or operated sprinklers. Prior to installation, sprinklers should be maintained in the original cartons and packaging until used to minimize the potential for damage to sprinklers that would cause improper operation or non-operation.

Model RFC30, RFC43 and RFC49 Residential Concealed Sprinkler Specification

Sprinklers shall be cULus Listed low flow residential concealed sprinklers with drop-down deflector and adjustable flat cover plate engineered for a minimum design density of 0.05 gpm/ft². Sprinkler frame and deflector shall be of bronze frame construction having a 1/2" NPT thread. Thermal element shall consist of an approved black-painted beryllium-nickel fusible solder link with symmetric lever mechanism, maintaining a Teflon-coated Belleville spring washer and machined brass cap water seal assembly containing no plastic parts. Sprinkler K-factor shall be nominal 3.0 (44), 4.3 (62.4), and 4.91 (70) having a 5/16", 3/8" and 7/16" orifice. Temperature rating shall be Ordinary 165°F (74°C); cover plate temperature rating to be 135°F (57°C). Cover plate assembly shall

consist of a brass cover plate and copper alloy retainer flange allowing a 1/2" cover plate adjustment. Any secure engagement between the cover plate and the cup will assure that the drop-down deflector is properly located below the ceiling. A plastic protective cap shall be provided and factory installed inside the sprinkler cup to protect the drop-down sprinkler deflector from damage, which could occur during construction before the cover plate is installed. Standard cover finish: [Chrome] [White] [Specialty – specify]. Residential concealed sprinklers shall be Reliable Model RFC30, SIN RA0611 (Bulletin 006), Model RFC43, SIN RA0612 (Bulletin 006) or Model RFC49, SIN RA0616 (Bulletin 006).

Ordering Information Specify:

1. Sprinkler Model
2. Cover Plate Finish
3. Thread-On or Push-On Feature

Cover Plate Finishes ⁽¹⁾

Standard Finishes
Chrome White
Special Application Finishes
Bright Brass Black Plating Black Paint Off White Satin Chrome

⁽¹⁾ Other colors and finishes available. Consult factory for details.

Note: Paint or any other coatings applied over the factory finish will void all approvals and warranties.

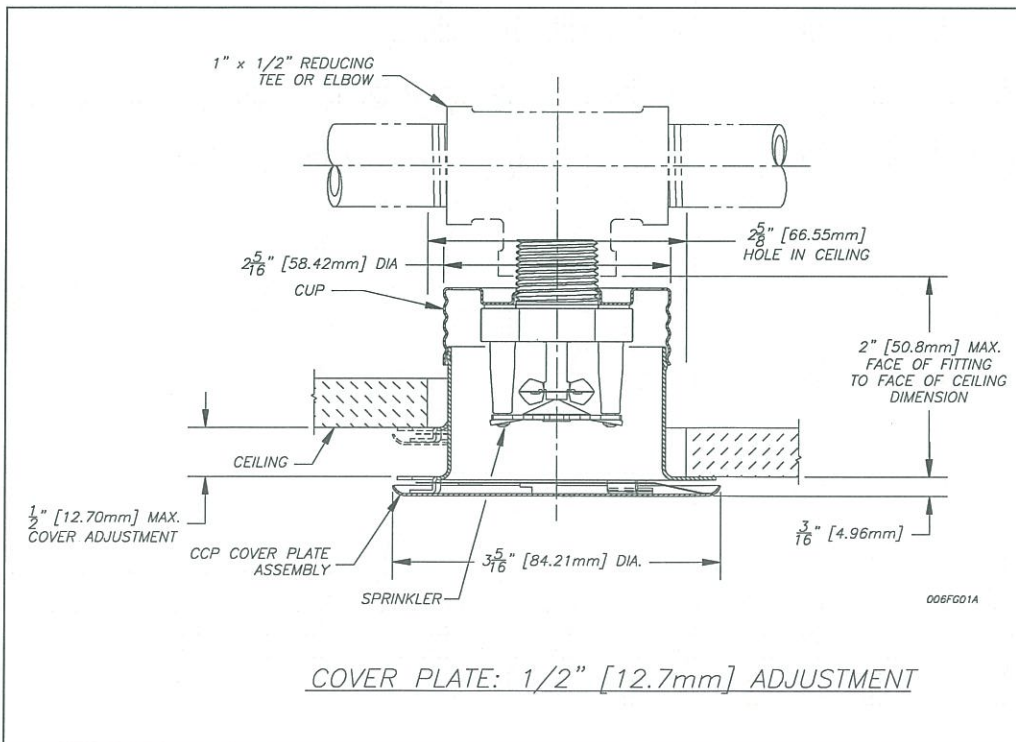

Reliable...For Complete Protection

Reliable offers a wide selection of sprinkler components. Following are some of the many precision-made Reliable products that guard life and property from fire around the clock.

- Automatic sprinklers
- Flush automatic sprinklers
- Recessed automatic sprinklers
- Concealed automatic sprinklers
- Adjustable automatic sprinklers
- Dry automatic sprinklers
- Intermediate level sprinklers
- Open sprinklers
- Spray nozzles
- Alarm valves
- Retarding chambers
- Dry pipe valves
- Accelerators for dry pipe valves
- Mechanical sprinkler alarms
- Electrical sprinkler alarm switches
- Water flow detectors
- Deluge valves
- Detector check valves
- Check valves
- Electrical system
- Sprinkler emergency cabinets
- Sprinkler wrenches
- Sprinkler escutcheons and guards
- Inspectors test connections
- Sight drains
- Ball drips and drum drips
- Control valve seals
- Air maintenance devices
- Air compressors
- Pressure gauges/identification signs
- Fire department connection

The equipment presented in this bulletin is to be installed in accordance with the latest published Standards of the National Fire Protection Association, Factory Mutual Research Corporation, or other similar organizations and also with the provisions of governmental codes or ordinances whenever applicable. Products manufactured and distributed by Reliable have been protecting life and property for over 90 years, and are installed and serviced by the most highly qualified and reputable sprinkler contractors located throughout the United States, Canada and foreign countries.

Manufactured by

Reliable[®]

The Reliable Automatic Sprinkler Co., Inc.
(800) 431-1588 Sales Offices
(800) 848-6051 Sales Fax
(914) 829-2042 Corporate Offices
www.reliablesprinkler.com Internet Address



Recycled
Paper

Revision lines indicate updated or new data.

EG. Printed in U.S.A 02/11 P/N 999970261