

**City of Portland, Maine - Building or Use Permit Application**

389 Congress Street, 04101 Tel: (207) 874-8703, Fax: (207) 874-8716

<b>PERMIT ISSUED</b>		
Permit No: 05-1840	Issue Date: JAN 11 2006	CBL: 382A D026001
Location of Construction: 17 LONGVIEW DR	Owner Name: NIAL CONSTRUCTION INC	Owner Address: 191 STATE RD #2
Business Name:	Contractor Name: Pine State Plumbing & Heating	Contractor Address: CITY OF PORTLAND PO Box 6308 Scarborough 2073212261
Lessee/Buyer's Name:	Phone:	Permit Type: HVAC
Past Use: Single Family	Proposed Use: Single Family install a direct vent fireplace w/ LP gas	Permit Fee: \$39.00
		Cost of Work: \$1,100.00
		CEO District: 5
		FIRE DEPT: <input checked="" type="checkbox"/> Approved <input type="checkbox"/> Denied
		INSPECTION: Use Group: <i>R-3/U</i> Type: <i>HAC</i> <i>State Gas Regs</i>
		Signature: _____
		Signature: _____
		PEDESTRIAN ACTIVITIES DISTRICT (P.A.D.):
		Action: <input type="checkbox"/> Approved <input type="checkbox"/> Approved w/Conditions <input type="checkbox"/> Denied
		Signature: _____ Date: _____

Permit Taken By: dmartin	Date Applied For: 12/30/2005
-----------------------------	---------------------------------

**Zoning Approval**

- This permit application does not preclude the Applicant(s) from meeting applicable State and Federal Rules.
- Building permits do not include plumbing, septic or electrical work.
- Building permits are void if work is not started within six (6) months of the date of issuance. False information may invalidate a building permit and stop all work..

Special Zone or Reviews <input type="checkbox"/> Shoreland <input type="checkbox"/> Wetland <input type="checkbox"/> Flood Hazard <input type="checkbox"/> Site Plan Maj <input type="checkbox"/> Minor <input type="checkbox"/> MM <input type="checkbox"/> Date: <i>1/13/06</i>	Zoning Appeal <input type="checkbox"/> Variance <input type="checkbox"/> Miscellaneous <input type="checkbox"/> Conditional Use <input type="checkbox"/> Interpretation <input type="checkbox"/> Approved <input type="checkbox"/> Denied Date: <i>01/13/06</i>	Historic Preservation <input checked="" type="checkbox"/> Not in District or Landmark <input type="checkbox"/> Does Not Require Review <input type="checkbox"/> Requires Review <input type="checkbox"/> Approved <input type="checkbox"/> Approved w/Conditions <input type="checkbox"/> Denied Date: <i>01/13/06</i>
---	--	---

SCANNED

*Closed out*

**CERTIFICATION**

I hereby certify that I am the owner of record of the named property, or that the proposed work is authorized by the owner of record and that I have been authorized by the owner to make this application as his authorized agent and I agree to conform to all applicable laws of this jurisdiction. In addition, if a permit for work described in the application is issued, I certify that the code official's authorized representative shall have the authority to enter all areas covered by such permit at any reasonable hour to enforce the provision of the code(s) applicable to such permit.

SIGNATURE OF APPLICANT	ADDRESS	DATE	PHONE
RESPONSIBLE PERSON IN CHARGE OF WORK, TITLE		DATE	PHONE

**City of Portland, Maine - Building or Use Permit**

389 Congress Street, 04101 Tel: (207) 874-8703, Fax: (207) 874-8716

Permit No:	Date Applied For:	CBL:
05-1840	12/30/2005	382A D026001

Location of Construction: 17 LONGVIEW DR	Owner Name: NIAL CONSTRUCTION INC	Owner Address: 191 STATE RD # 2	Phone:
Business Name:	Contractor Name: Pine State Plumbing & Heating	Contractor Address: PO Box 6308 Scarborough	Phone: (207) 321-2261
Lessee/Buyer's Name	Phone:	Permit Type: HVAC	

Proposed Use: Single Family install a direct vent fireplace w/ LP gas	Proposed Project Description: Installing a direct vent fireplace w/ LP gas
--	---

Dept: Zoning      Status: Approved      Reviewer: Tammy Munson      Approval Date: 01/13/2006  
Note:      Ok to Issue:

Dept: Building      Status: Approved with Conditions      Reviewer: Tammy Munson      Approval Date: 01/13/2006  
Note:      Ok to Issue:

1) The installation must comply with the State of Maine Gas Regulations.



FILL IN AND SIGN WITH INK

# APPLICATION FOR PERMIT HEATING OR POWER EQUIPMENT

382 AD 026

Big duct #  
050325

To the INSPECTOR OF BUILDINGS, PORTLAND, ME.

The undersigned hereby applies for a permit to install the following heating, cooking or power equipment in accordance with the Laws of Maine, the Building Code of the City of Portland, and the following specifications:

Location / CBL 17 LONGVIEW DRIVE Use of Building HOME Date 12-23-05  
Name and address of owner of appliance NICK'S CONSTRUCTION

Installer's name and address RICHARD A. PROFENNO HEATING  
58 CHRISTY RD PORTLAND ME Telephone 7974953 - CELL 674408

**Location of appliance:**  
 Basement  Floor  
 Attic  Roof

**Type of Fuel:**  
 Gas  Oil  Solid

**Appliance Name:** PERKLESS BURNER WB  
U.L. Approved  Yes  No

Will appliance be installed in accordance with the manufacture's installation instructions?  Yes  No

IF NO Explain: \_\_\_\_\_

**The Type of License of Installer:**  
 Master Plumber # \_\_\_\_\_  
 Solid Fuel # \_\_\_\_\_  
 Oil # MS30000600  
 Gas # \_\_\_\_\_  
 Other \_\_\_\_\_

**Type of Chimney:**  
 Masonry Lined  
Factory built \_\_\_\_\_

Metal  
Factory Built U.L. Listing # \_\_\_\_\_

Direct Vent  
Type \_\_\_\_\_ UL# \_\_\_\_\_

**Type of Fuel Tank**  
 Oil  
 Gas

Size of Tank 275

Number of Tanks 1

Distance from Tank to Center of Flame 25 feet.

Cost of Work: \$ 5000.00

Permit Fee: \$ Code

**Approved**

Fire: \_\_\_\_\_  
Ele.: \_\_\_\_\_  
Bldg.: q Howe

**Approved with Conditions**

See attached letter or requirement  
Inspector's Signature \_\_\_\_\_ Date Approved \_\_\_\_\_

Signature of Installer \_\_\_\_\_

White - Inspection    Yellow - File    Pink - Applicant's    Gold - Assessor's Copy

PINE STATE PLUMBING & HEATING, INC.  
P.O. Box 6308  
Scarborough, ME 04070-6308  
Tel: 207-321-2261  
Fax: 207-321-2270  
5 Industry Rd  
South Portland, ME 04106



# FAX

To: Donna From: Steve McCusker  
Company: \_\_\_\_\_ Pages: 6  
Fax: 874-8716 Date: 12-22-05  
Subject: \_\_\_\_\_

Comments:

Room Above garage

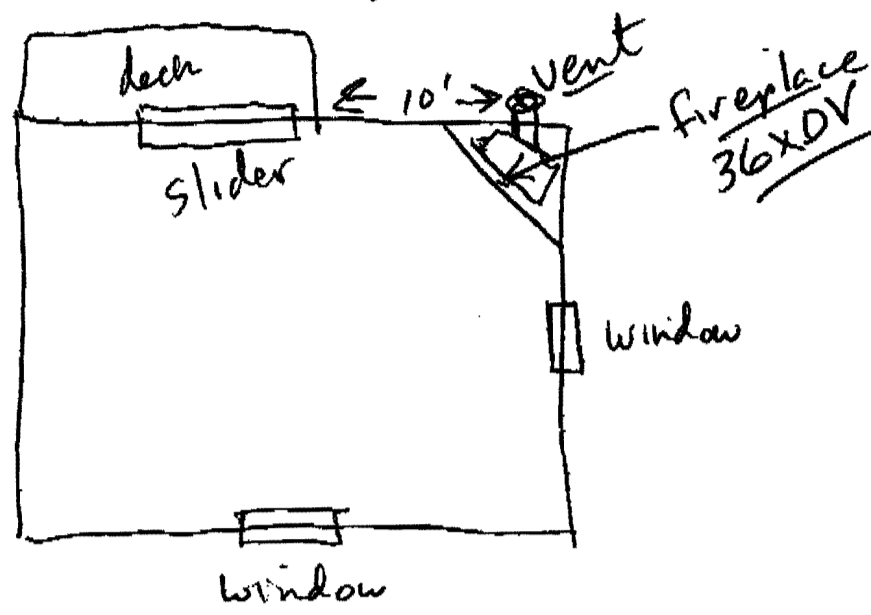

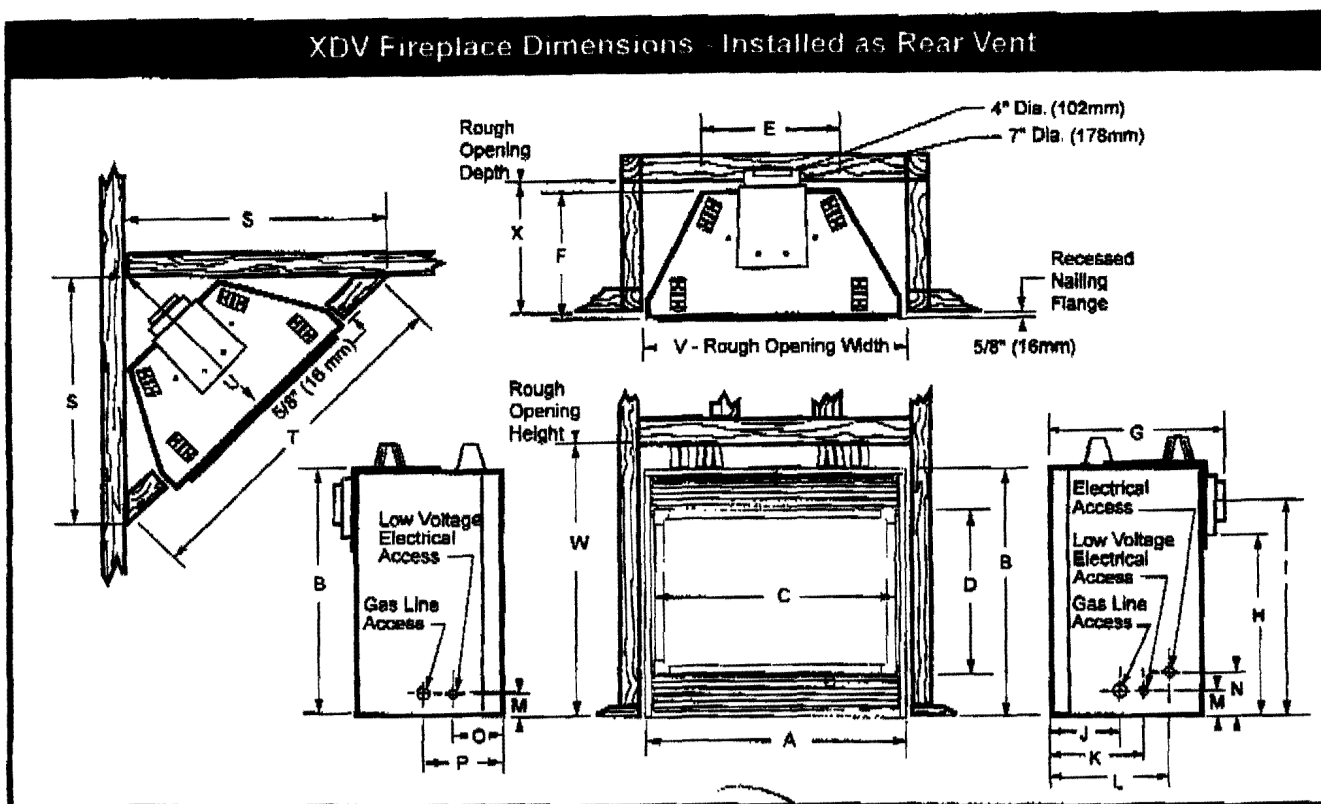

Fig. 2 Fireplace specifications and framing dimensions.

Ref.	33XDV	36XDV	39 XDV
A	33" (838 mm)	36" (914 mm)	39" (991 mm)
B	28 1/2" (733 mm)	34 1/2" (870 mm)	34 1/2" (870 mm)
C	31 1/2" (794 mm)	34 1/2" (870 mm)	37 1/2" (946 mm)
D	18 3/4" (466 mm)	23" (584 mm)	23" (584 mm)
E	22 3/4" (578 mm)	24" (610 mm)	27" (686 mm)
F	14 3/4" (365 mm)	15 1/2" (413 mm)	15 1/2" (413 mm)
G	18 3/4" (466 mm)	18 3/4" (478 mm)	18 3/4" (478 mm)
H	19 3/4" (487 mm)	24 1/2" (616 mm)	24 1/2" (616 mm)
I	22 1/2" (576 mm)	28 1/2" (714 mm)	28 1/2" (714 mm)
J	4 3/4" (118 mm)	5 3/4" (143 mm)	5 3/4" (143 mm)
K	5 3/4" (160 mm)	8" (203 mm)	8" (203 mm)
L	8 7/8" (225 mm)	11 7/8" (302 mm)	11 7/8" (302 mm)
M	2" (51 mm)	2" (51 mm)	2" (51 mm)
N	3 3/4" (85 mm)	3 1/4" (82 mm)	3 1/4" (82 mm)
O	4 3/4" (118 mm)	6 3/4" (171 mm)	6 3/4" (171 mm)
P	6 3/4" (162 mm)	9 1/4" (235 mm)	9 1/4" (235 mm)
<b>Framing Dimensions</b>			
S	36" (914 mm)	41 3/4" (1057 mm)	44" (1118 mm)
T	51" (1295 mm)	58 3/4" (1495 mm)	62 1/2" (1581 mm)
U	25 1/2" (641 mm)	28 3/4" (748 mm)	31 1/2" (790 mm)
V	33 1/2" (851 mm)	36 1/2" (927 mm)	39 1/2" (1003 mm)
W	31" (787 mm)	38 3/4" (980 mm)	38 3/4" (980 mm)
X	14 1/2" (378 mm)	16 3/4" (428 mm)	16 3/4" (428 mm)

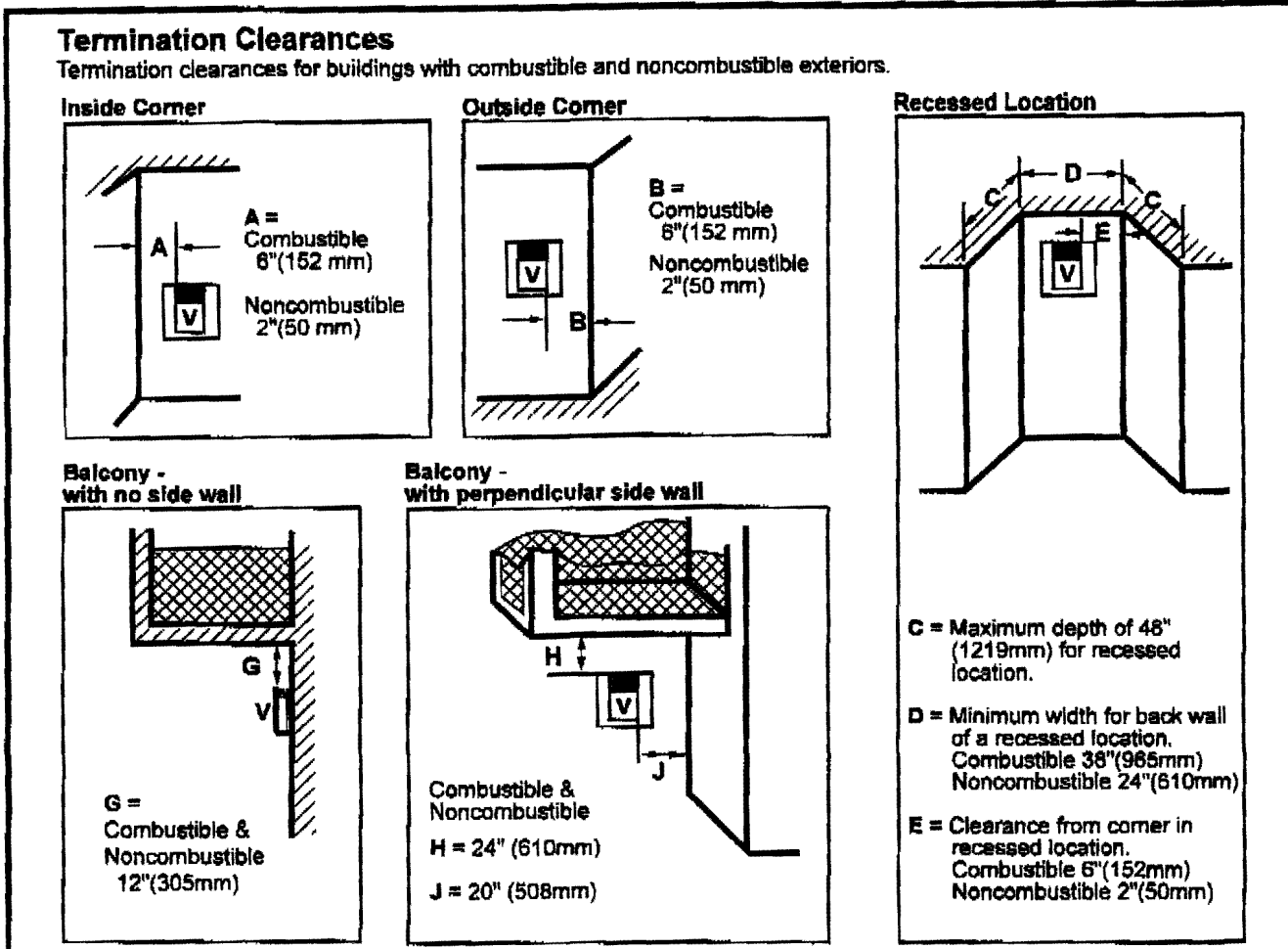

Fig. 16 Termination clearances.

General Information Assembling Vent Pipes

**Canadian Installations:**

Venting system must be installed in accordance with the current CSA-B149.1 installation code.

**USA Installations:**

The venting system must conform with local codes and/or the current National Fuel Gas code ANSI Z223.1/ NFPA 54.

Only venting components manufactured by CFM Corporation can be used in Direct Vent systems.

**Flex Vent Pipes**

Before joining the flex vent pipe to the unit, apply a bead of high temperature sealant\* (provided) to the 4" pipe exiting the fireplace. Secure flex vent pipe in place with a hose clamp (provided).

\*Be sure the flex pipe overlaps at least 1" (25mm) onto the collars of the fireplace and termination. If the termination has an internal bead, be sure to overlap and secure 1" (25mm) past the bead.

\* Be sure the flex vent is flat and flush with the flue or outer collar before proceeding. Apply a tug to be sure the vent will not slip off the collars. Repeat process with 7" flex vent pipe. The same procedure must be performed on the vent side.

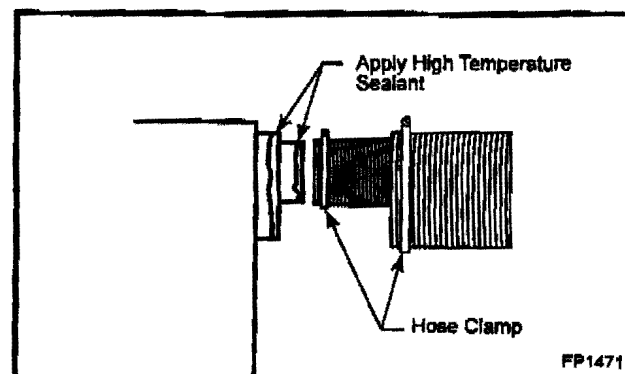
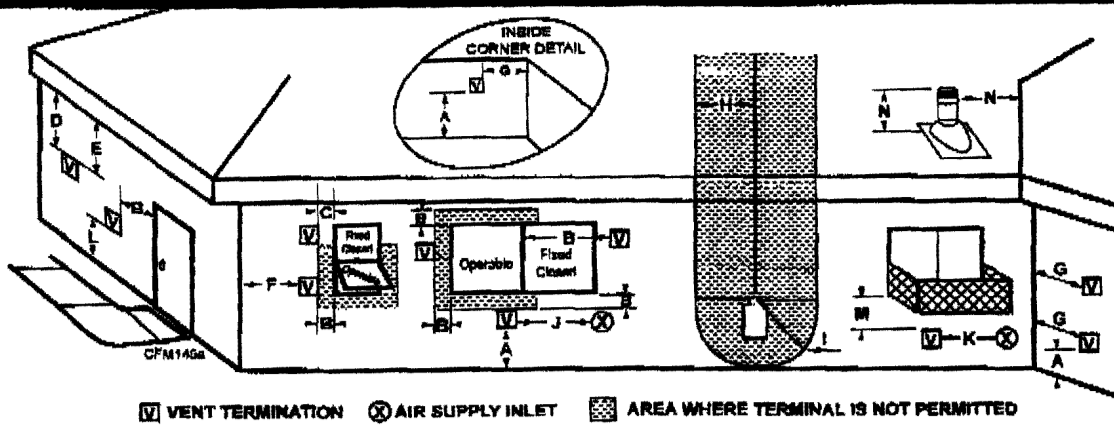

Fig. 17 Apply high temperature sealant to 4" and 7" pipes.

General Venting Information - Termination Location



	Canadian Installations <sup>1</sup>	US Installations <sup>2</sup>
A = Clearance above grade, veranda, porch, deck, or balcony	12" (30cm)	12" (30cm)
B = Clearance to window or door that may be opened	6" (15cm) for appliances < 10,000 Btuh (3kW), 12" (30cm) for appliances > 10,000 Btuh (3kW) and < 100,000 Btuh (30kW), 36" (91cm) for appliances > 100,000 Btuh (30kW)	6" (15cm) for appliances < 10,000 Btuh (3kW), 9" (23cm) for appliances > 10,000 Btuh (3kW) and < 50,000 Btuh (15kW), 12" (30cm) for appliances > 50,000 Btuh (15kW)
C = Clearance to permanently closed window	12" (305mm) recommended to prevent window condensation	12" (305mm) recommended to prevent window condensation
D = Vertical clearance to ventilated soffit located above the terminal within a horizontal distance of 2' (610mm) from the center line of the terminal	18" (458mm)	18" (458mm)
E = Clearance to unventilated soffit	12" (305mm)	12" (305mm)
F = Clearance to outside corner	see next page	see next page
G = Clearance to inside corner (see next page)	see next page	see next page
H = Clearance to each inside of center line extended above meter/regulator assembly	3' (91cm) within a height of 15' (5m) above the meter/regulator assembly	3' (91cm) within a height of 15' (5m) above the meter/regulator assembly
I = Clearance to service regulator vent outlet	3' (91cm)	3' (91cm)
J = Clearance to nonmechanical air supply inlet to building or the combustion air inlet to any other appliances	6" (15cm) for appliances < 10,000 Btuh (3kW), 12" (30cm) for appliances > 10,000 Btuh (3kW) and < 100,000 Btuh (30kW), 36" (91cm) for appliances > 100,000 Btuh (30kW)	6" (15cm) for appliances < 10,000 Btuh (3kW), 9" (23cm) for appliances > 10,000 Btuh (3kW) and < 50,000 Btuh (15kW), 12" (30cm) for appliances > 50,000 Btuh (15kW)
K = Clearance to a mechanical air supply inlet	6" (1.53m)	3' (91cm) above if within 10 feet (3m) horizontally
L = Clearance above paved sidewalk or paved driveway located on public property	7' (2.13m)†	7' (2.13m)†
M = Clearance under veranda, porch, deck or balcony	12" (30cm)‡	12" (30cm)‡
N = Clearance above a roof shall extend a minimum of 24" (610mm) above the highest point when it passes through the roof surface, and any other obstruction within a horizontal distance of 18" (450mm).		

<sup>1</sup> In accordance with the current CSA-B149 Installation Codes  
<sup>2</sup> In accordance with the current ANSI Z223.1/NFPA 54 National Fuel Gas Codes  
 † A vent shall not terminate directly above a sidewalk or paved driveway which is located between two single family dwellings and serves both dwellings  
 ‡ only permitted if veranda, porch, deck or balcony is fully open on a minimum 2 sides beneath the floor.  
 NOTE: 1. Local codes or regulations may require different clearances.  
 2. The special venting system used on Direct Vent Stoves are certified as part of the appliance, with clearances tested and approved by the listing agency.

10007920

13

**Clearance to Combustibles**

Top of Unit to Ceiling .....	36" (914 mm)
Front of Unit to Combustibles .....	36" (914 mm)
<b>Appliance</b>	
Top of Standoff .....	0" (0 mm)
Bottom .....	0" (0 mm)
Side .....	0" (0 mm)
Back .....	0" (0 mm)
<b>Venting</b>	
Concentric sections of DV Vent .....	1" (25 mm)
Nonconcentric sections of DV Vent	
Sides and Bottom .....	1" (25 mm)
Top .....	2" (51 mm)

**Mantels**

The height that a combustible mantel is fitted above the fireplace is dependent on the depth of the mantel. This also applies to the distance between the mantel leg (if fitted) and the fireplace.

For the correct mounting height and widths refer to Figs. 5a and 5b, and the following Mantel Charts.

The fitting of a bay window trim kit does not effect the distances and reference points referred to in the diagram and chart.

Noncombustible mantels and legs may be installed at any height and width around the appliance. When using paint or lacquer to finish the mantel, such paint or lacquer must be heat resistant to prevent discoloration.

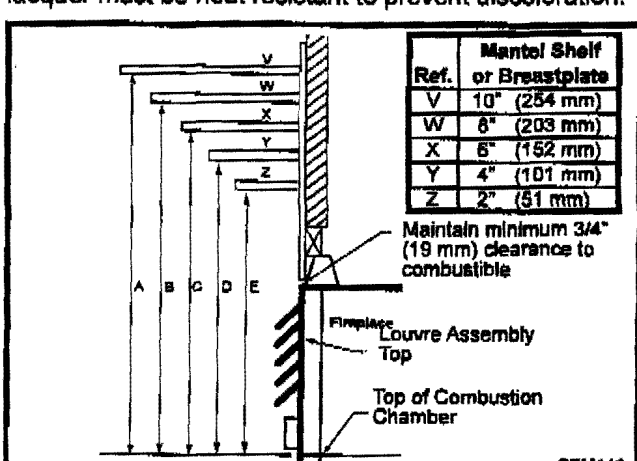

Mantel Chart			
Ref.	Mantel from Top of Combustion Chamber		
	33XDV/XDVR	36XDV	39XDV
A	18 1/2" (470 mm)	19" (482 mm)	20" (508 mm)
B	16 1/2" (419 mm)	17" (432 mm)	18" (457 mm)
C	14 1/2" (368 mm)	15" (381 mm)	16" (406 mm)
D	12 1/2" (318 mm)	13" (330 mm)	14" (355 mm)
E	10 1/2" (267 mm)	11" (279 mm)	12" (305 mm)

Fig. 5a Combustible mantel minimum installation.

10007920

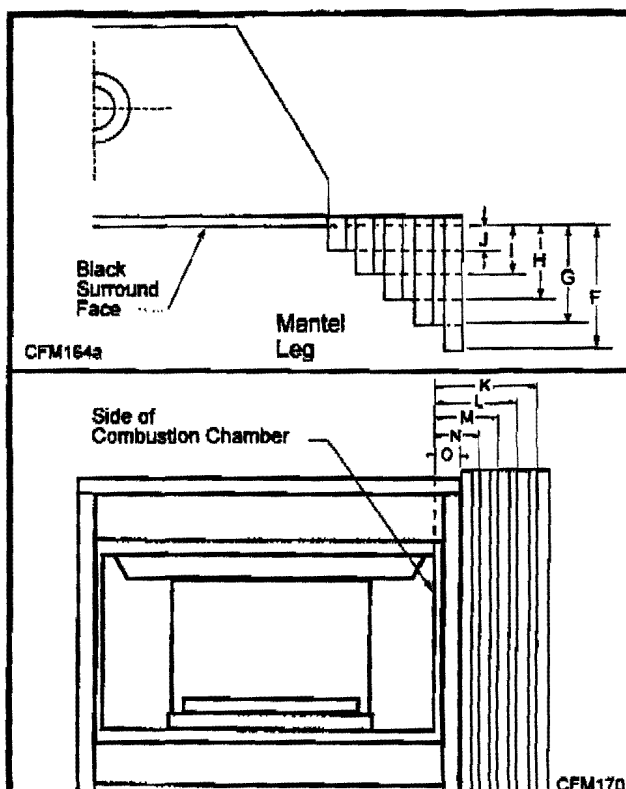

Ref.	Mantel Leg Depth	Ref.	Mantel Leg From Side of Comb. Opening
F	10" (254 mm)	K	11 1/2" (292 mm)
G	8" (203 mm)	L	9 1/2" (241 mm)
H	6" (152 mm)	M	7 1/2" (191 mm)
I	4" (101 mm)	N	5 1/2" (140 mm)
J	2" (50 mm)	O	3 1/2" (89 mm)

Fig. 5b Combustible mantel leg minimum installation.

**Hearth**

A hearth is not mandatory but is recommended for aesthetic purposes. We recommend a noncombustible hearth which projects out 12" (305mm) or more from the front of the fireplace.

**Cold climate installation recommendation:**

**When installing this unit against a non-insulated exterior wall or chase, it is mandatory that the outer walls be insulated to conform to applicable insulation codes.**

**Proposition 65 Warning:** Fuels used in gas, wood-burning or oil fired appliances, and the products of combustion of such fuels, contain chemicals known to the State of California to cause cancer, birth defects and other reproductive harm.  
California Health & Safety Code Sec. 25249.6

7



<b>INSTALLER/CONSUMER SAFETY INFORMATION</b>
<b>PLEASE READ THIS MANUAL BEFORE INSTALLING AND USING APPLIANCE</b>
<b>WARNING!</b> IF THE INFORMATION IN THIS MANUAL IS NOT FOLLOWED EXACTLY, A FIRE OR EXPLOSION MAY RESULT CAUSING PROPERTY DAMAGE, PERSONAL INJURY OR LOSS OF LIFE.
<b>FOR YOUR SAFETY</b> Installation and service must be performed by a qualified installer, service agency or the gas supplier.
<b>WHAT TO DO IF YOU SMELL GAS:</b> <ul style="list-style-type: none"> <li>• Do not try to light any appliance.</li> <li>• Do not touch any electric switch; do not use any phone in your building.</li> <li>• Immediately call your gas supplier from your neighbor's phone. Follow the gas suppliers instructions.</li> <li>• If you cannot reach your gas supplier call the fire department.</li> </ul>
<b>DO NOT STORE OR USE GASOLINE OR OTHER FLAMMABLE VAPORS AND LIQUIDS IN THE VICINITY OF THIS OR ANY OTHER APPLIANCE.</b>

# MAJESTIC VERMONT *Castings*

**Direct Vent Models:**

**33XDV, 33XDVR,  
36XDV, 39XDV**

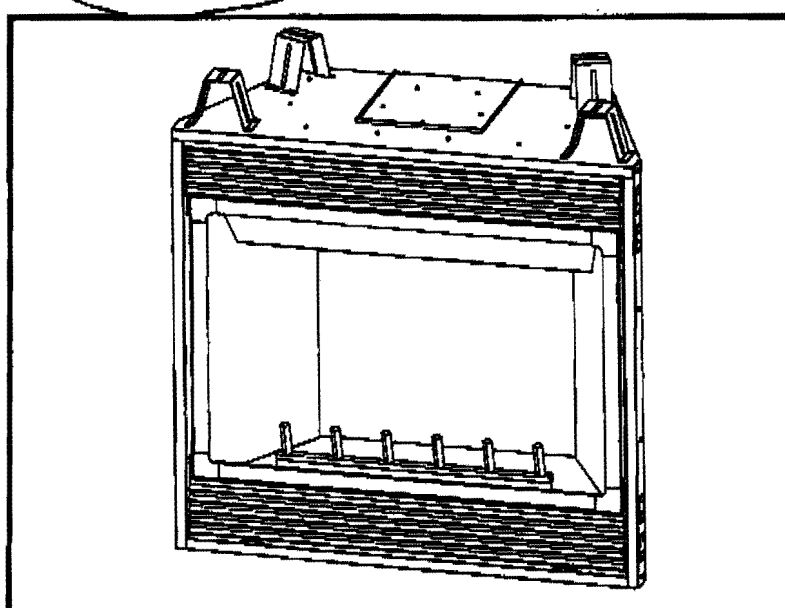

**Installation Instructions and  
Homeowner's Manual**



**CFM Specialty Home Products**

410 Admiral Blvd. - Mississauga, Ontario, Canada L5T 2N6 • 905-670-7777  
www.majesticproducts.com • www.vermontcastings.com

**INSTALLER: DO NOT DISCARD THIS MANUAL - LEAVE FOR HOMEOWNER**

10007920 11/05 Rev. 2