

DISPLAY THIS CARD ON PRINCIPAL FRONTAGE OF WORK

CITY OF PORTLAND

BU CTION

PERMIT

Permit Number: 091117

Please Read Application And Notes, If Any, Attached

This is to certify that VERRILLO PATRICIA P / Day Dipietro

has permission to Turn existing car port into garage

AT 56 FALL LN

CB 379 A005001

provided that the person or persons, firm or corporation accepting this permit shall comply with all of the provisions of the Statutes of Maine and of the Ordinances of the City of Portland regulating the construction, maintenance and use of buildings and structures, and of the application on file in this department.

Apply to Public Works for street line and grade if nature of work requires such information.

Notification of inspection must be given and written permission procured before this building or part thereof is lathed or otherwise red-in. 24 HOUR NOTICE IS REQUIRED.

A certificate of occupancy must be procured by owner before this building or part thereof is occupied.

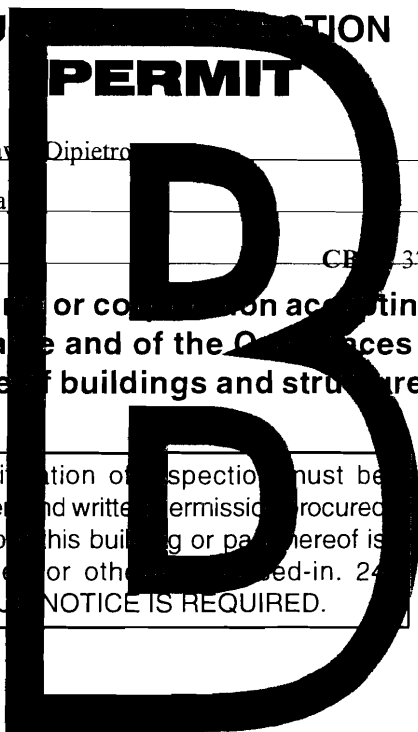

OTHER REQUIRED APPROVALS

Fire Dept. _____

Health Dept. _____

Appeal Board _____

Other _____

Department Name

Thomas H. MacLellan 10/13/09
Director - Building & Inspection Services

PENALTY FOR REMOVING THIS CARD

BUILDING PERMIT INSPECTION PROCEDURES

Please call 874-8703 or 874-8693 (ONLY)

to schedule your inspections as agreed upon

Permits expire in 6 months, if the project is not started or ceases for 6 months.

The Owner or their designee is required to notify the inspections office for the following inspections and provide adequate notice. Notice must be called in 48-72 hours in advance in order to schedule an inspection:

By initializing at each inspection time, you are agreeing that you understand the inspection procedure and additional fees from a "Stop Work Order" and "Stop Work Order Release" will be incurred if the procedure is not followed as stated below.

A Pre-construction Meeting will take place upon receipt of your building permit.

 X **Footing/Building Location Inspection: Prior to pouring concrete or setting precast piers**

 X **Framing/Rough Plumbing/Electrical: Prior to Any Insulating or drywalling**

 X **Final inspection required at completion of work.**

Certificate of Occupancy is not required for certain projects. Your inspector can advise you if your project requires a Certificate of Occupancy. All projects DO require a final inspection.

If any of the inspections do not occur, the project cannot go on to the next phase, REGARDLESS OF THE NOTICE OR CIRCUMSTANCES.

CERIFICATE OF OCCUPANICES MUST BE ISSUED AND PAID FOR, BEFORE THE SPACE MAY BE OCCUPIED.



Signature of Applicant/Designee

 10-13-09

Date



Signature of Inspections Official

 10-13-09

Date

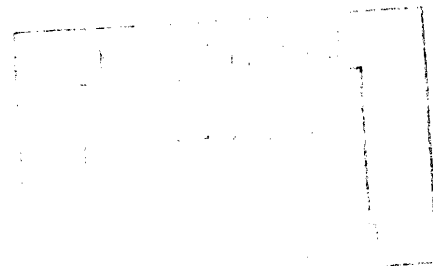

City of Portland, Maine - Building or Use Permit Application

389 Congress Street, 04101 Tel: (207) 874-8703, Fax: (207) 874-8716

Permit No: 09-1117	Issue Date:	CBL: 379 A005001
-----------------------	-------------	---------------------

Location of Construction: 56 FALL LN	Owner Name: VERRILLO PATRICIA P	Owner Address: 56 FALL LN	Phone:
Business Name:	Contractor Name: David Dipietro	Contractor Address: 221 Virginia Street Portland	Phone 2078317914
Lessee/Buyer's Name	Phone:	Permit Type: Additions - Dwellings	Zone: R-2

Past Use: Single Family Home	Proposed Use: Single Family Home - Turn existing car port into garage	Permit Fee: \$90.00	Cost of Work: \$7,000.00	CEO District: 5	130904 1
		FIRE DEPT: <input type="checkbox"/> Approved <input type="checkbox"/> Denied	INSPECTION: Use Group: R3 Type: SB IRC 2003		

Proposed Project Description: Turn existing car port into garage	Signature:	Signature: <i>Jm 10/13/09</i>
PEDESTRIAN ACTIVITIES DISTRICT (P.A.D.)		
Action: <input type="checkbox"/> Approved <input type="checkbox"/> Approved w/Conditions <input type="checkbox"/> Denied		
Signature: _____ Date: _____		

Permit Taken By: Ldobson	Date Applied For: 10/07/2009	Zoning Approval
-----------------------------	---------------------------------	------------------------

<p>1. This permit application does not preclude the Applicant(s) from meeting applicable State and Federal Rules.</p> <p>2. Building permits do not include plumbing, septic or electrical work.</p> <p>3. Building permits are void if work is not started within six (6) months of the date of issuance. False information may invalidate a building permit and stop all work..</p>	<p>Special Zone or Reviews</p> <input type="checkbox"/> Shoreland <input type="checkbox"/> Wetland <input type="checkbox"/> Flood Zone <input type="checkbox"/> Subdivision <input type="checkbox"/> Site Plan Maj <input type="checkbox"/> Minor <input type="checkbox"/> MM <input type="checkbox"/> Date: <i>10/8/09</i>	<p>Zoning Appeal</p> <input type="checkbox"/> Variance <input type="checkbox"/> Miscellaneous <input type="checkbox"/> Conditional Use <input type="checkbox"/> Interpretation <input type="checkbox"/> Approved <input type="checkbox"/> Denied Date: _____	<p>Historic Preservation</p> <input checked="" type="checkbox"/> Not in District or Landmark <input type="checkbox"/> Does Not Require Review <input type="checkbox"/> Requires Review <input type="checkbox"/> Approved <input type="checkbox"/> Approved w/Conditions <input type="checkbox"/> Denied Date: _____

CERTIFICATION

I hereby certify that I am the owner of record of the named property, or that the proposed work is authorized by the owner of record and that I have been authorized by the owner to make this application as his authorized agent and I agree to conform to all applicable laws of this jurisdiction. In addition, if a permit for work described in the application is issued, I certify that the code official's authorized representative shall have the authority to enter all areas covered by such permit at any reasonable hour to enforce the provision of the code(s) applicable to such permit.

SIGNATURE OF APPLICANT ADDRESS DATE PHONE

RESPONSIBLE PERSON IN CHARGE OF WORK, TITLE DATE PHONE

11/4/09 - checked foundation wall for
Bachfield - OK - Setbacks OK - NO ISSUES -
OK to start building.

John

City of Portland, Maine - Building or Use Permit

389 Congress Street, 04101 Tel: (207) 874-8703, Fax: (207) 874-8716

Permit No: 09-1117	Date Applied For: 10/07/2009	CBL: 379 A005001
------------------------------	--	----------------------------

Location of Construction: 56 FALL LN	Owner Name: VERRILLO PATRICIA P	Owner Address: 56 FALL LN	Phone:
Business Name:	Contractor Name: David Dipietro	Contractor Address: 221 Virginia Street Portland	Phone (207) 831-7914
Lessee/Buyer's Name	Phone:	Permit Type: Additions - Dwellings	

Proposed Use: Single Family Home - Turn existing car port into garage	Proposed Project Description: Turn existing car port into garage
---	--

Dept: Zoning	Status: Approved with Conditions	Reviewer: Marge Schmuckal	Approval Date: 10/08/2009
Note:	Ok to Issue: <input checked="" type="checkbox"/>		
<ol style="list-style-type: none"> 1) Separate permits shall be required for future decks, sheds, pools, and/or garages. 2) This is NOT an approval for an additional dwelling unit. You SHALL NOT add any additional kitchen equipment including, but not limited to items such as stoves, microwaves, refrigerators, or kitchen sinks, etc. Without special approvals. 3) This property shall remain a single family dwelling. Any change of use shall require a separate permit application for review and approval. 4) This permit is being approved on the basis of plans submitted. Any deviations shall require a separate approval before starting that work. 			
Dept: Building	Status: Approved with Conditions	Reviewer: Tom Markley	Approval Date: 10/13/2009
Note:	Ok to Issue: <input checked="" type="checkbox"/>		
<ol style="list-style-type: none"> 1) Separate permits are required for any electrical, plumbing, sprinkler, fire alarm or HVAC or exhaust systems. Separate plans may need to be submitted for approval as a part of this process. 2) Application approval based upon information provided by applicant. Any deviation from approved plans requires separate review and approval prior to work. 			

Comments:
10/7/2009-mes: I asked David D. To remeasure the front setback. His submittal shows the carport to be 24' from the front property line instead of the 25' required. David thought it was much more than that. He will get back to me.
10/8/2009-mes: David came in and revised the front set back - He said it measured 30 feet. OK per zoning



General Building Permit Application

If you or the property owner owes real estate or personal property taxes or user charges on any property within the City, payment arrangements must be made before permits of any kind are accepted.

Location/Address of Construction: 56 FALL LANE			
Total Square Footage of Proposed Structure/Area 360		Square Footage of Lot 13,090	Number of Stories 1
Tax Assessor's Chart, Block & Lot Chart# Block# Lot# 379 A 5	Applicant *must be owner, Lessee or Buyer* Name LEWIS VERRILLI Address 56 FALL LANE City, State & Zip PORTLAND		Telephone: 8317914
Lessee/DBA (If Applicable)	Owner (if different from Applicant) Name Address City, State & Zip	Cost Of Work: \$ 7,000 C of O Fee: \$ Total Fee: \$ 90	
Current legal use (i.e. single family) CAR PORT Number of Residential Units 1 If vacant, what was the previous use? Proposed Specific use: GARAGE Is property part of a subdivision? NO If yes, please name Project description: TURN CAR PORT INTO GARAGE			
Contractor's name: DAVID DIPIETRO			
Address: 221 VIRGINIA ST PORTLAND			
City, State & Zip ME 04103		Telephone: 8317914	
Who should we contact when the permit is ready: DAVID		Telephone:	
Mailing address: SAME			

Please submit all of the information outlined on the applicable Checklist. Failure to do so will result in the automatic denial of your permit.

In order to be sure the City fully understands the full scope of the project, the Planning and Development Department may request additional information prior to the issuance of a permit. For further information or to download copies of this form and other applications visit the Inspections Division on-line at www.portlandmaine.gov, or stop by the Inspections Division office, room 315 City Hall or call 874-8703.

I hereby certify that I am the Owner of record of the named property, or that the owner of record authorized me to make this application as his/her authorized agent. I agree to conform to all applicable laws of this jurisdiction. In addition, if a permit for work described in this application is issued, I certify that the Code Official's authorized representative shall have the authority to enter all areas covered by this permit at any reasonable hour to enforce the provisions of the codes applicable to this permit.

Signature:

Date:

10-5-9

This is not a permit; you may not commence ANY work until the permit is issued

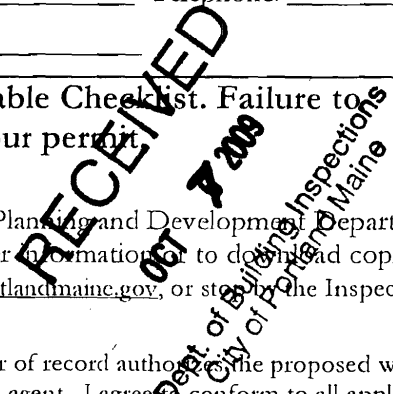

R2

lot size 13,090
land area per acre 19,000 sq ft
front 25' min - ~~25'~~ 31'
rear 25' min 65' max
side 12' min - 21' max
lot coverage - 20% = 2618 sq ft

existing 2150
deck 240 (20x12)
ramp 66.6 (40"x 20)
5456.6

← 12' →

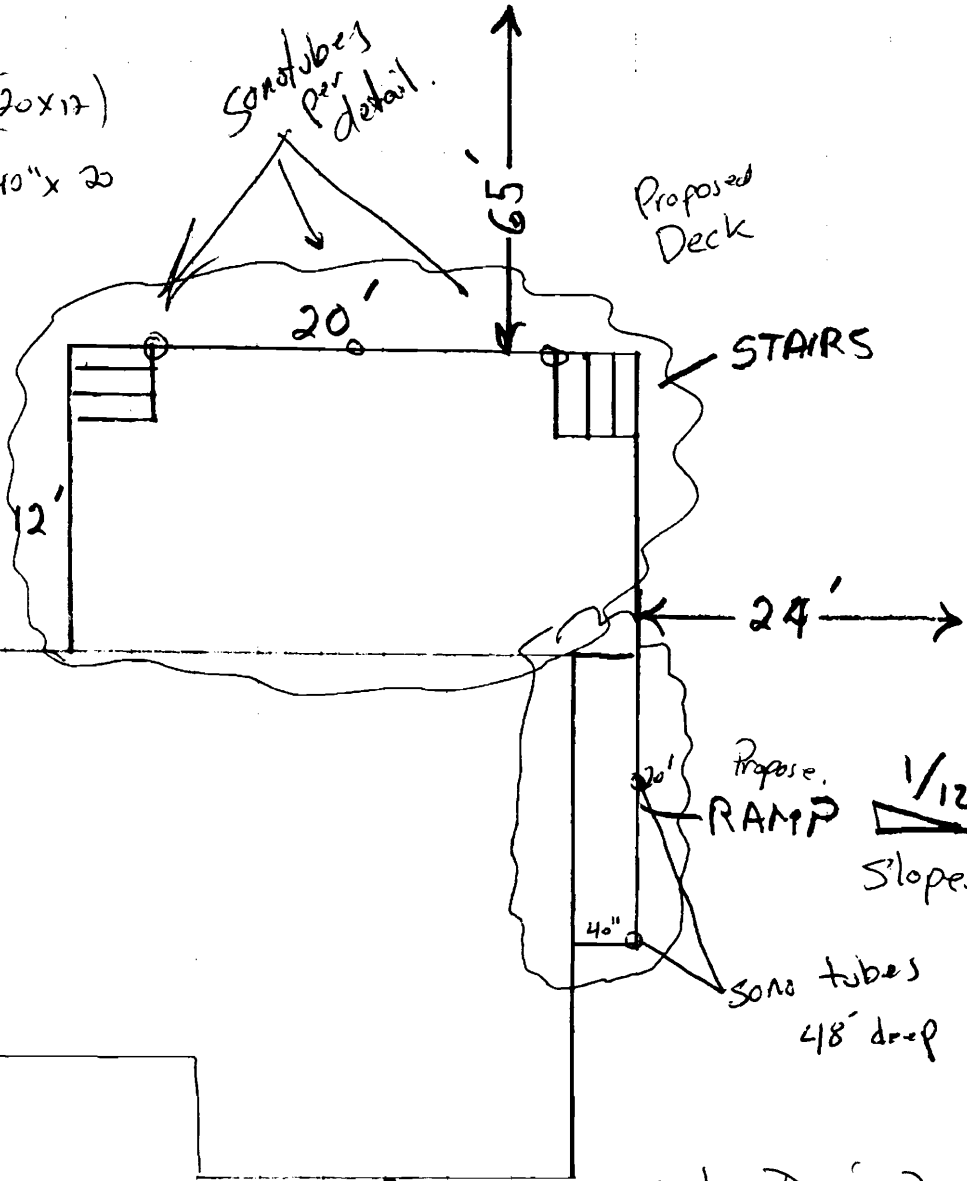
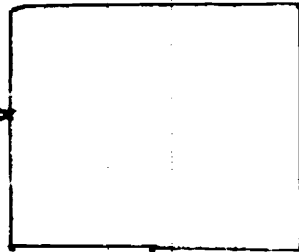

built 1962

R-2 Zone

10/8/09
of

FRONT: 25' min req - 30' shown
REAR: 25' req 65' from REAR of Bldg
SIDE: 12' req - 24' + shown

Fall Lane

30' ~~30'~~ revised by David Dipietro 10/8/09



56 FALL LANE

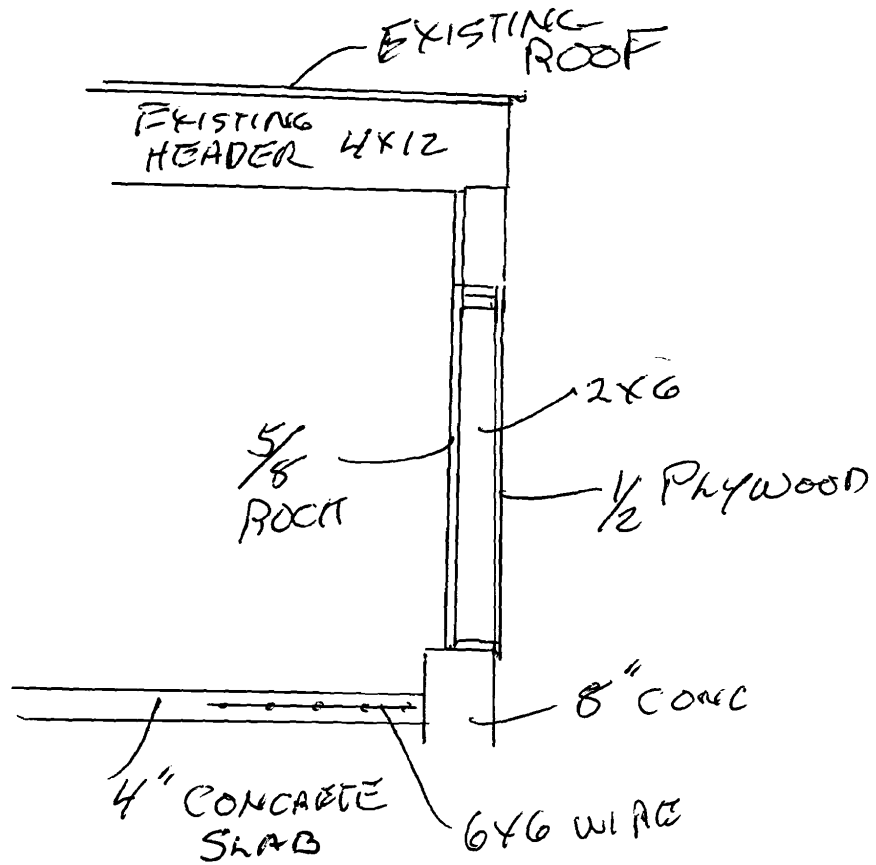
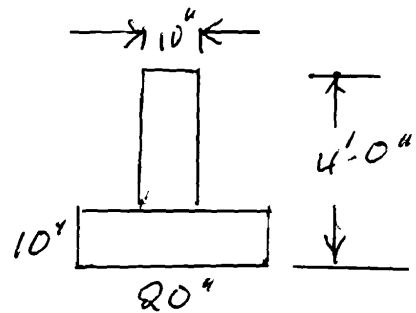

BUILDING PERMIT INSPECTION PROCEDURES

Please call 874-8703 or 874-8693 (ONLY)

to schedule your inspections as agreed upon

Permits expire in 6 months, if the project is not started or ceases for 6 months.

The Owner or their designee is required to notify the inspections office for the following inspections and provide adequate notice. Notice must be called in 48-72 hours in advance in order to schedule an inspection:

By initializing at each inspection time, you are agreeing that you understand the inspection procedure and additional fees from a "Stop Work Order" and "Stop Work Order Release" will be incurred if the procedure is not followed as stated below.

A Pre-construction Meeting will take place upon receipt of your building permit.

Footing/Building Location Inspection: Prior to pouring concrete or setting precast piers

Framing/Rough Plumbing/Electrical: Prior to Any Insulating or drywalling

Final inspection required at completion of work.

Certificate of Occupancy is not required for certain projects. Your inspector can advise you if your project requires a Certificate of Occupancy. All projects DO require a final inspection.

If any of the inspections do not occur, the project cannot go on to the next phase, REGARDLESS OF THE NOTICE OR CIRCUMSTANCES.

CERIFICATE OF OCCUPANICES MUST BE ISSUED AND PAID FOR, BEFORE THE SPACE MAY BE OCCUPIED.



Signature of Applicant/Designee

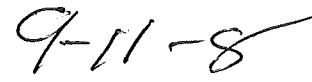

Date

Signature of Inspections Official

Date