

6 ELEVATION VIEW
A-6.1 N.T.S.
CLEAN RUN ON REPACK,
DROP-OFF, & DATA ENTRY

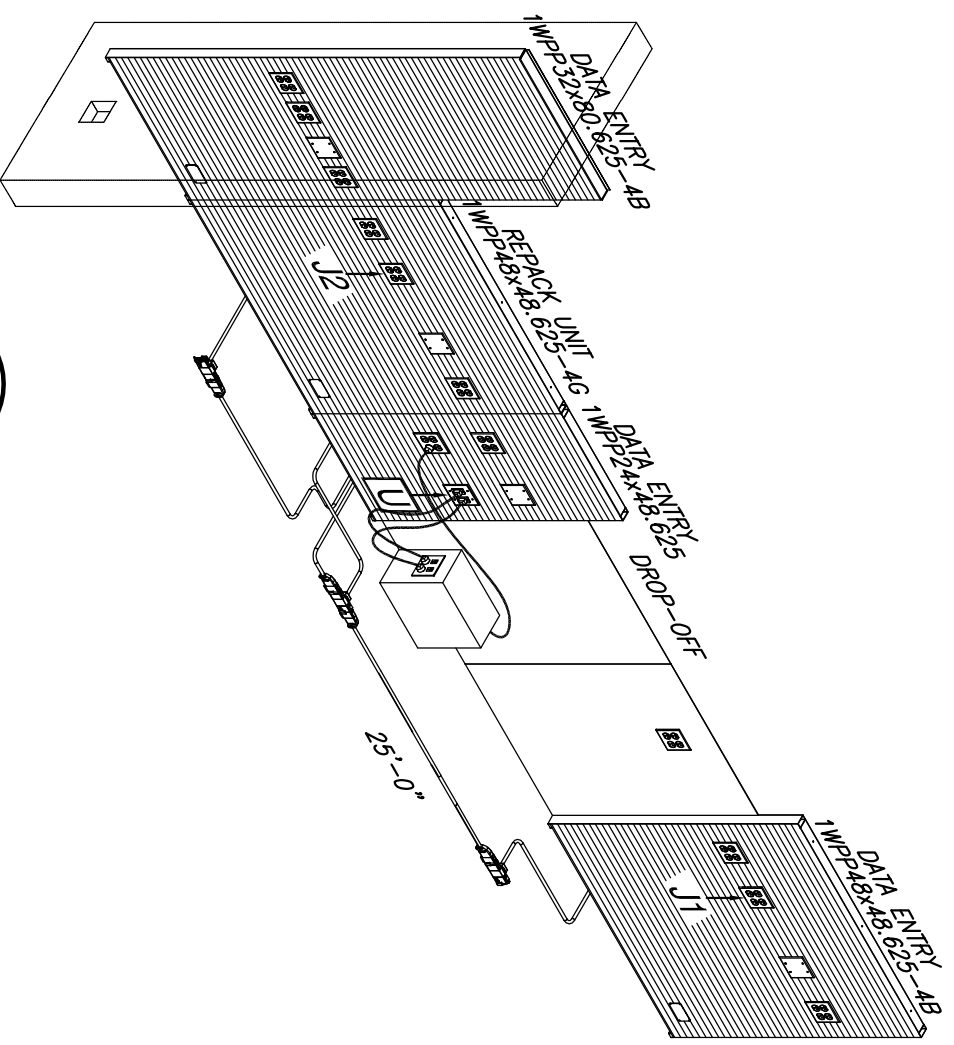

6 ELEVATION VIEW
A-6.1 N.T.S.
J1 & J2 RUN ON REPACK,
DROP-OFF, & DATA ENTRY

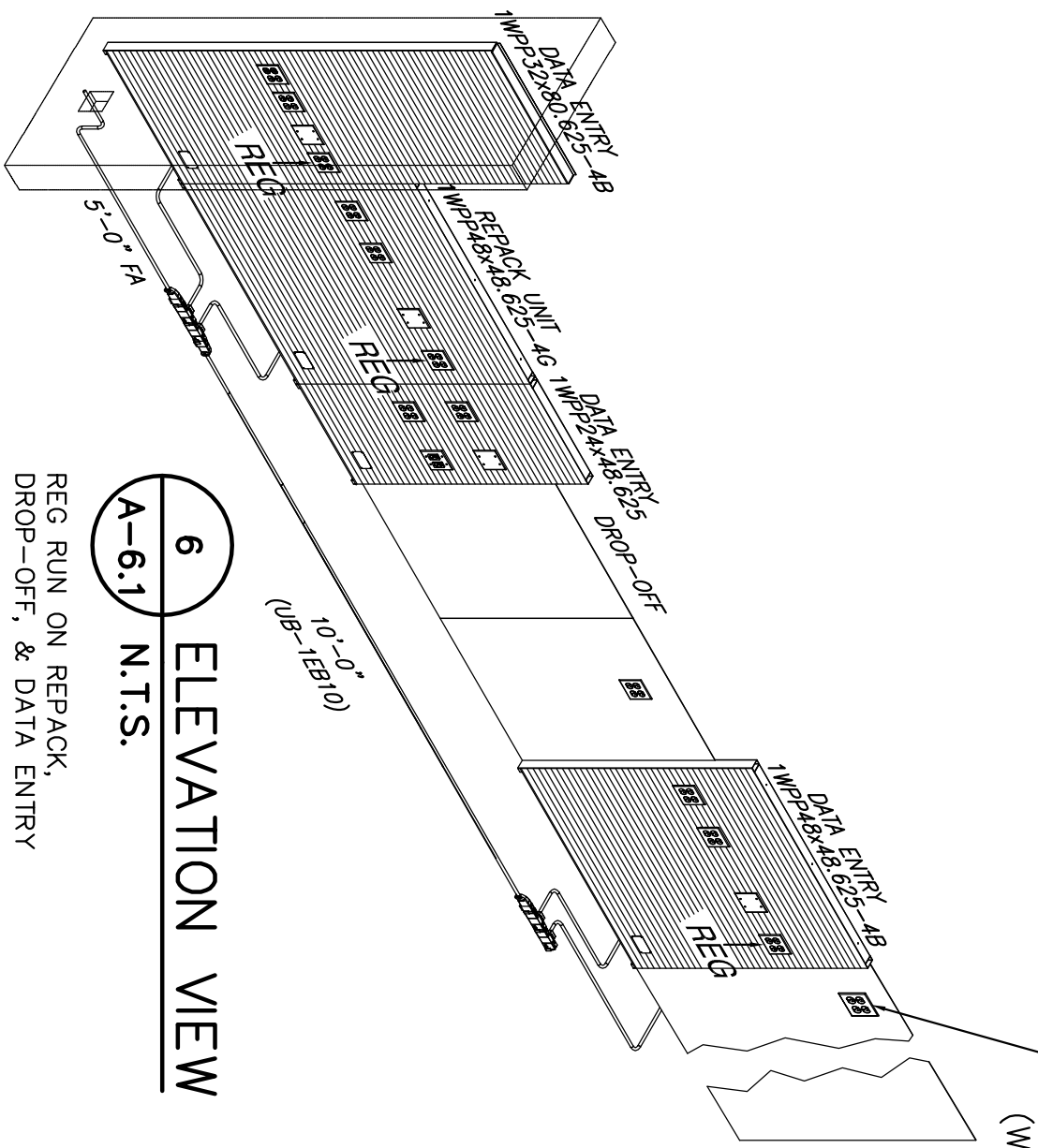

6 ELEVATION VIEW
A-6.1 N.T.S.
REG RUN ON REPACK,
DROP-OFF, & DATA ENTRY

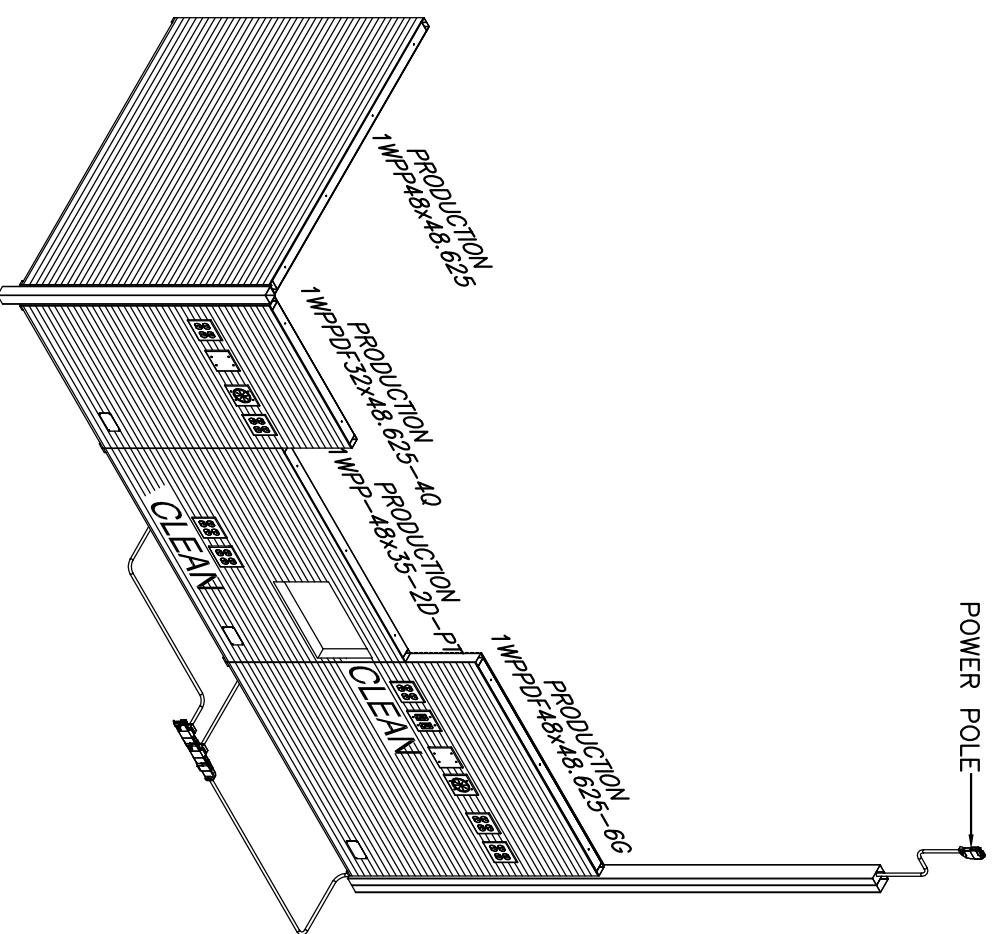

5 ELEVATION VIEW
A-6.1 N.T.S.
CLEAN RUN ON FILL SIDE
OF FILL STATION

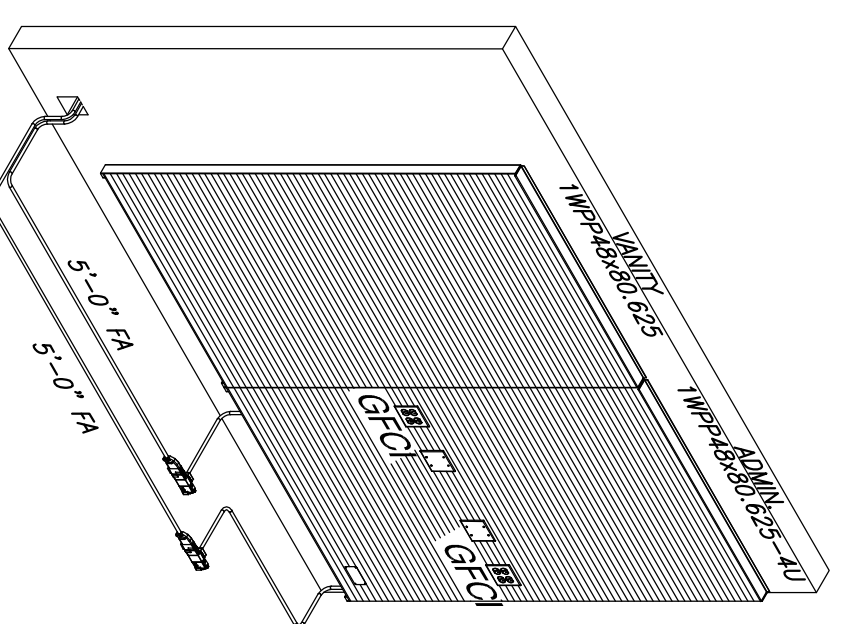

7 ELEVATION VIEW
A-6.1 N.T.S.
GFCI RUN ON ADMIN & VANITY

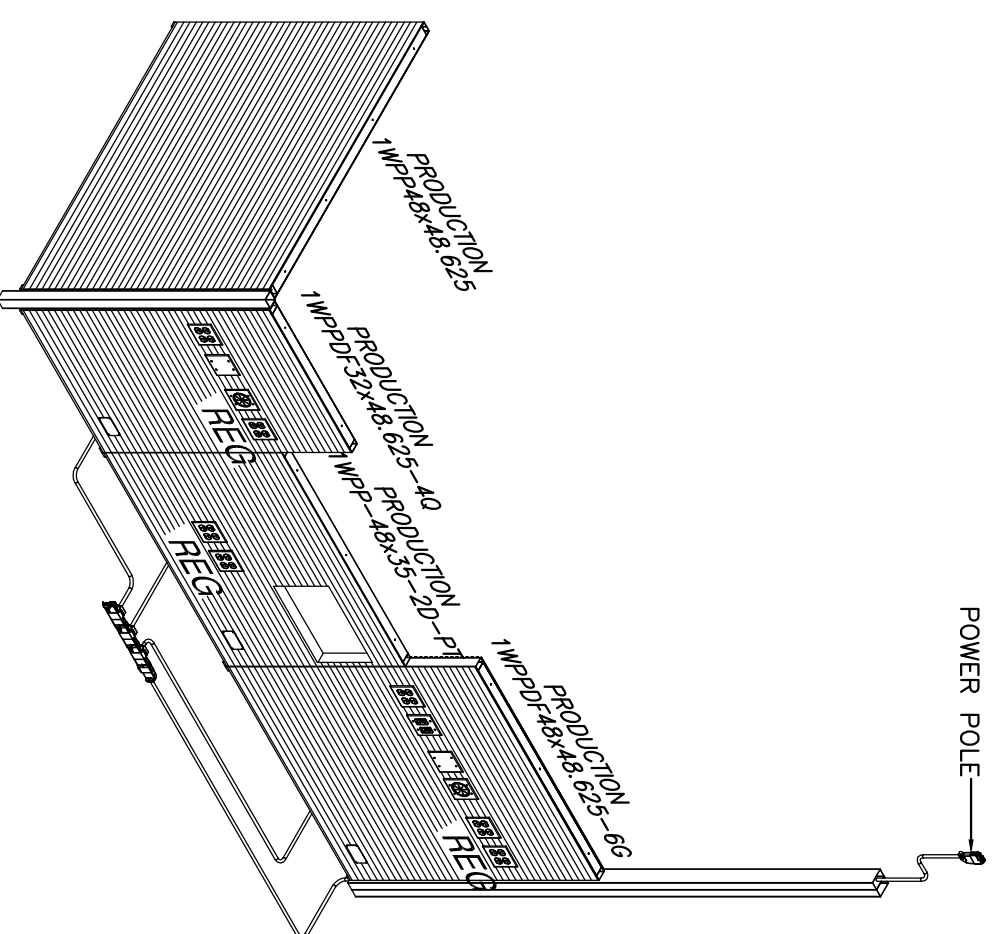

5 ELEVATION VIEW
A-6.1 N.T.S.
REG RUN ON FILL SIDE
OF FILL STATION

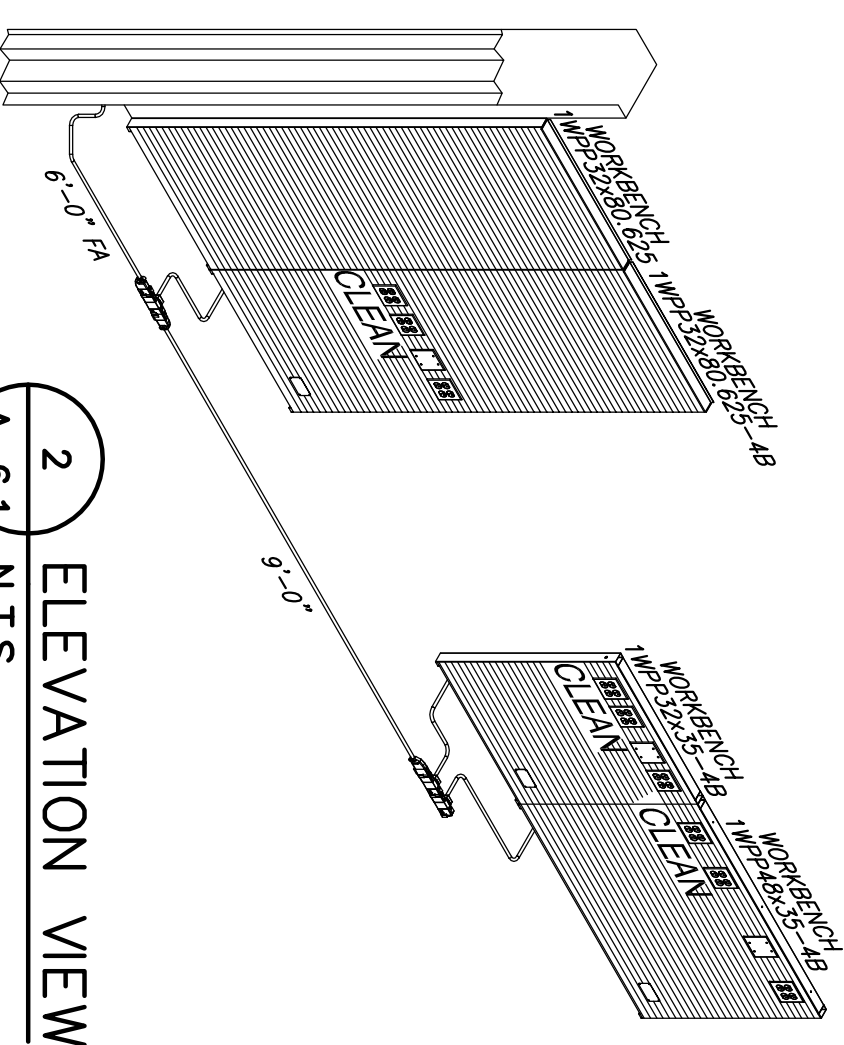

2 ELEVATION VIEW
A-6.1 N.T.S.
CLEAN RUN ON WORKBENCH

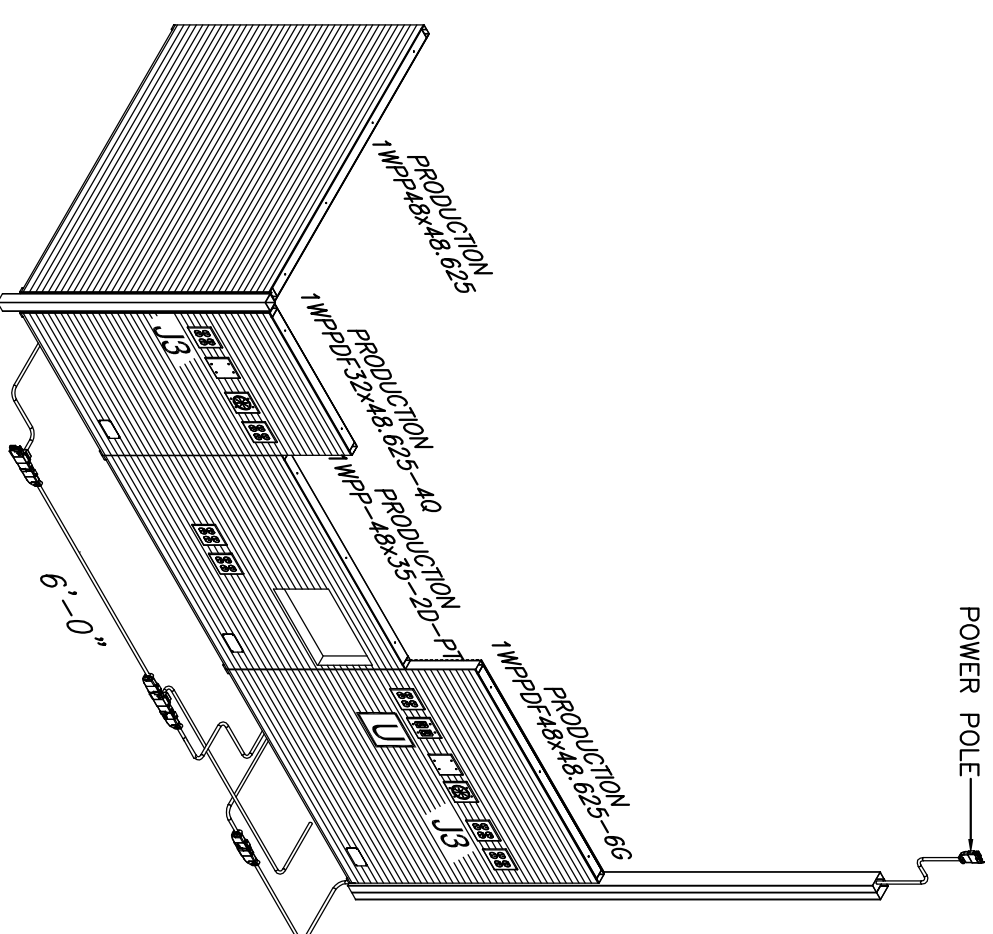

5 ELEVATION VIEW
A-6.1 N.T.S.
REG RUN ON FILL SIDE
OF FILL STATION

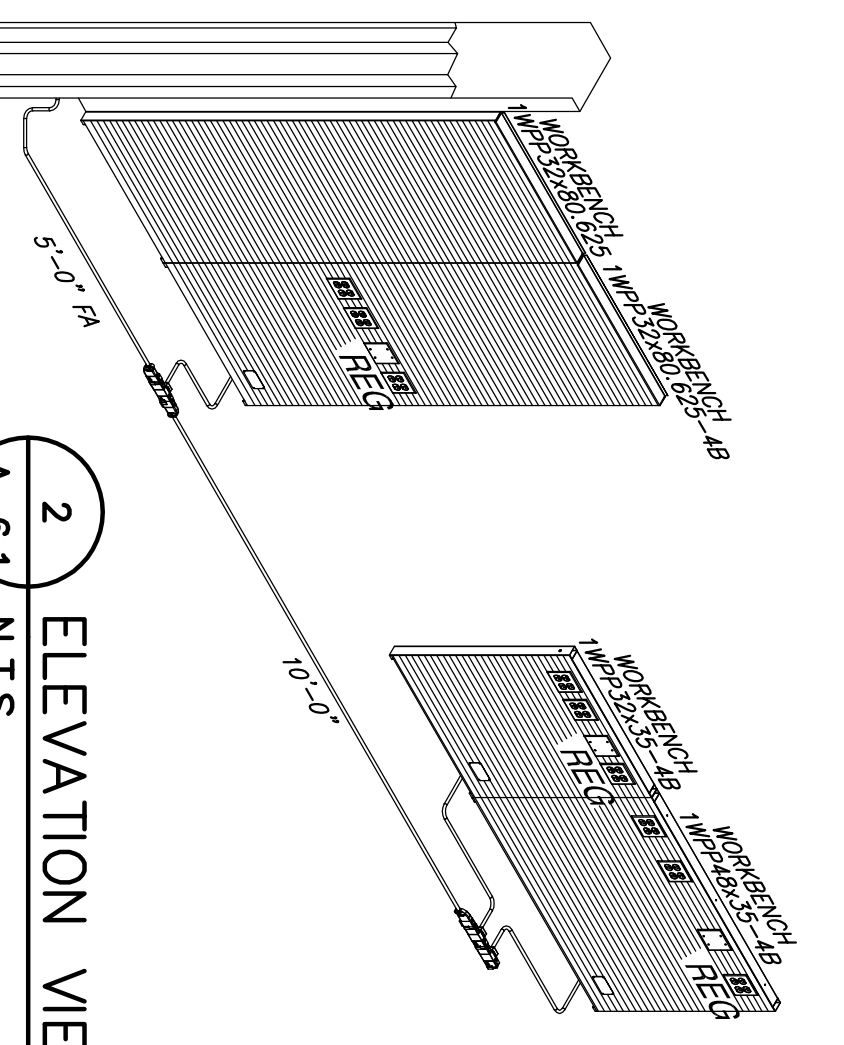

2 ELEVATION VIEW
A-6.1 N.T.S.
REG RUN ON WORKBENCH

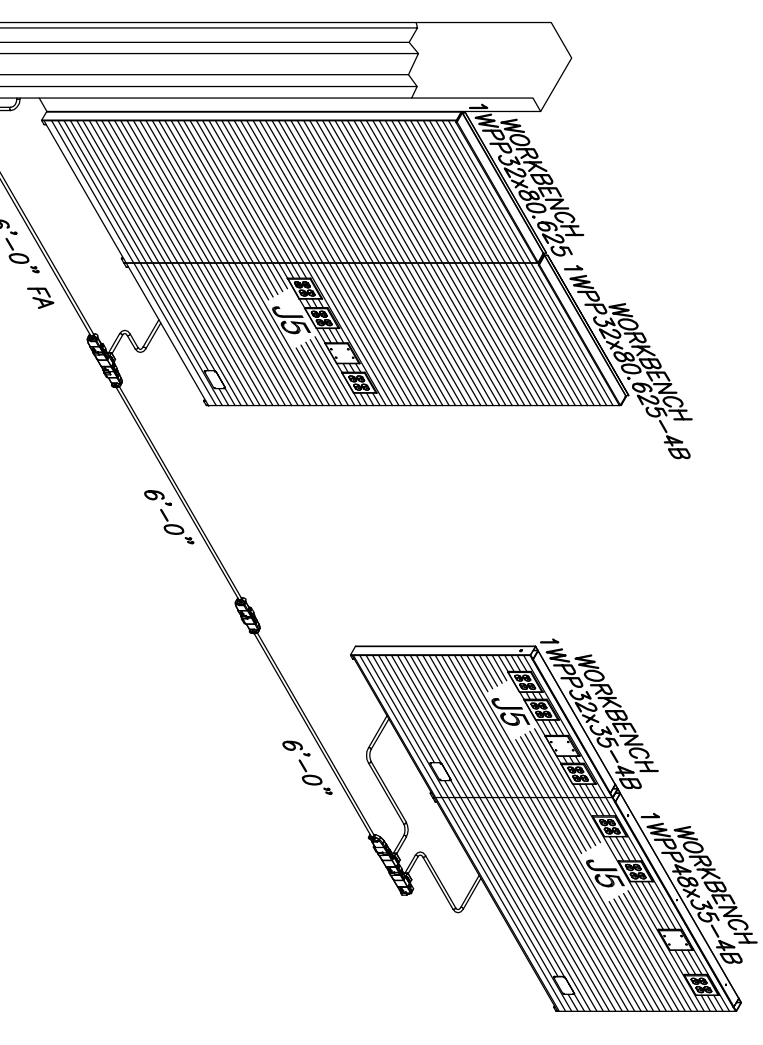

2 ELEVATION VIEW
A-6.1 N.T.S.
REG RUN ON WORKBENCH

A-48 x 81, A-48 x 31, B-48 x 31, C-48 x 31

6 ELEVATION VIEW
A-6.1 N.T.S.
CLEAN RUN ON DATA ENTRY
& CHECKOUT

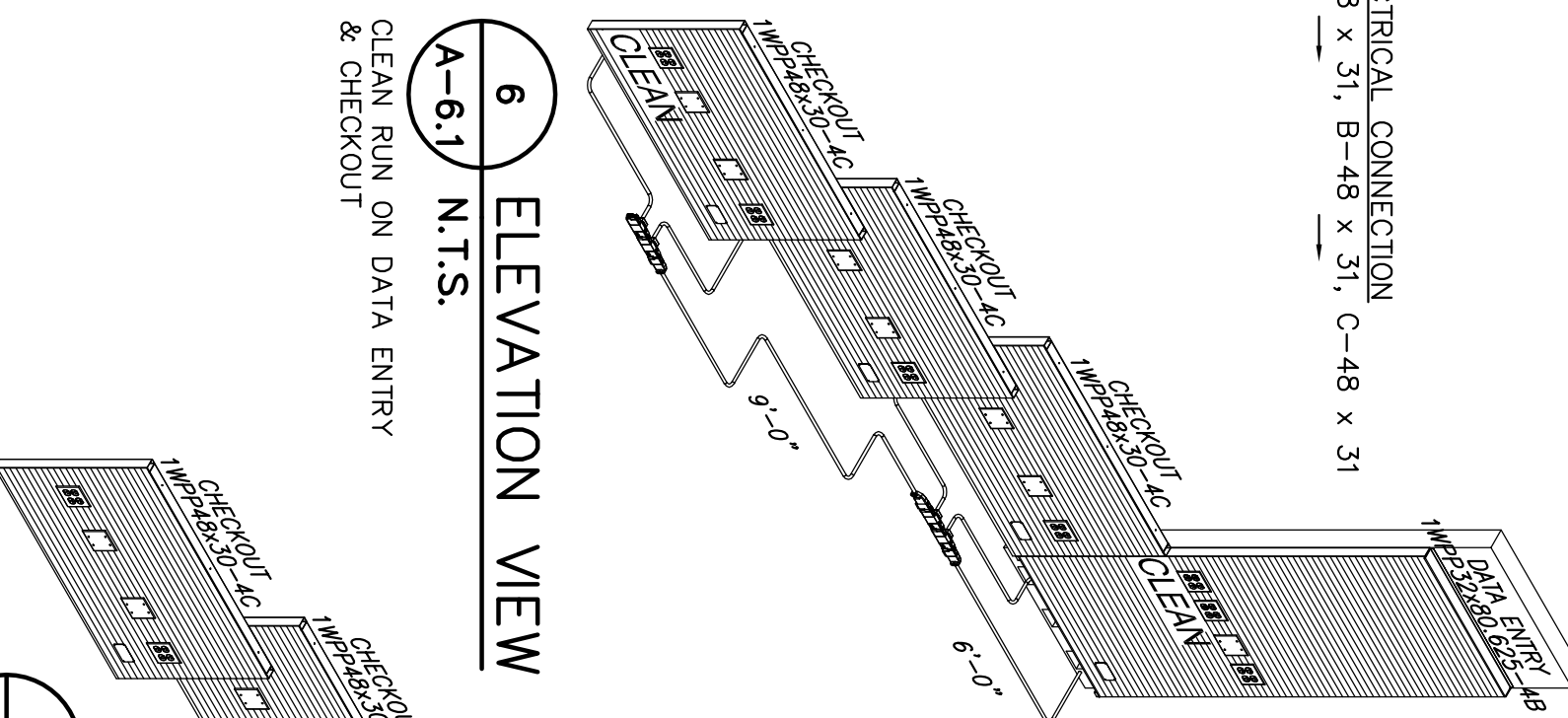

A-48 x 81, A-48 x 31, B-48 x 31, C-48 x 31

6 ELEVATION VIEW
A-6.1 N.T.S.
REG RUN ON DATA ENTRY
& CHECKOUT

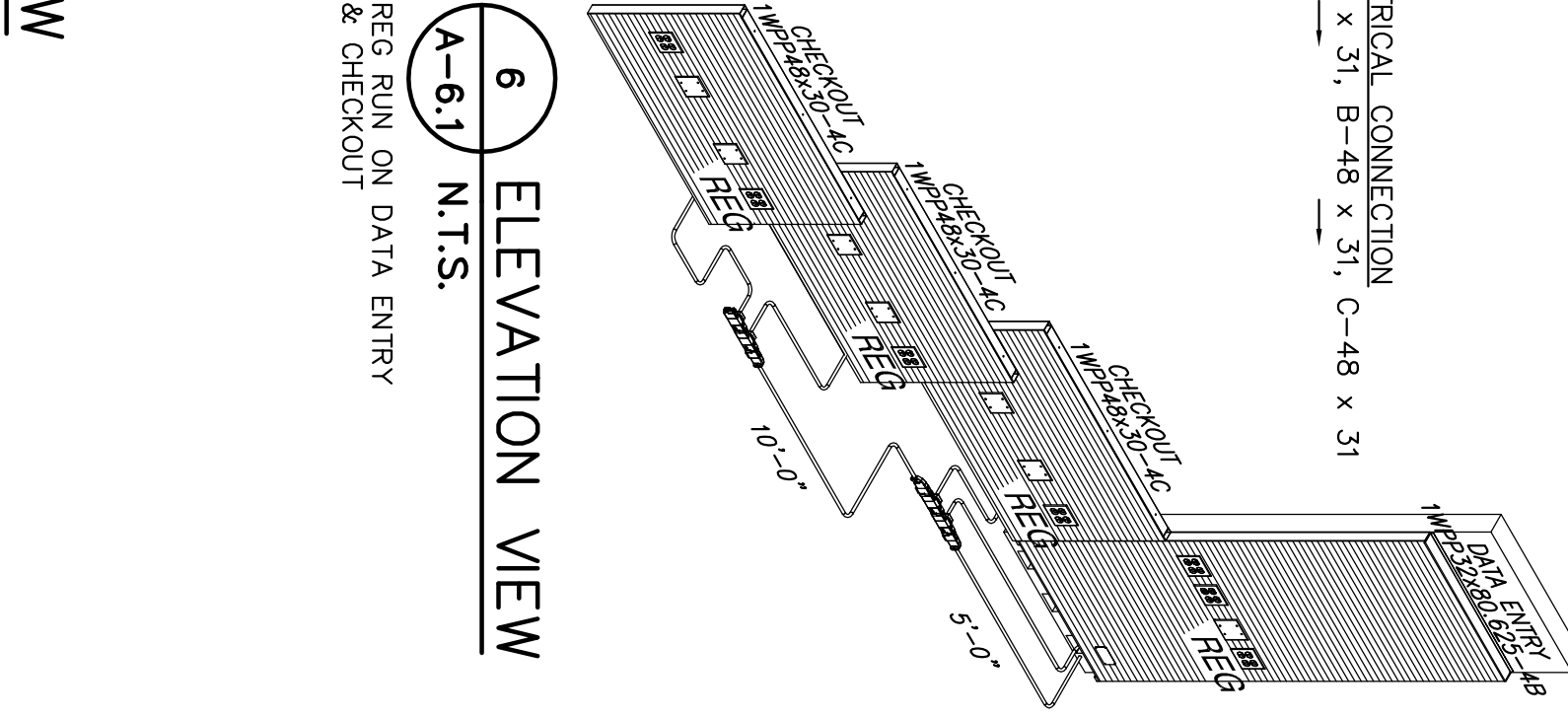

UPS CONNECTIONS ON I.A. UNIT
(AS APPLICABLE)

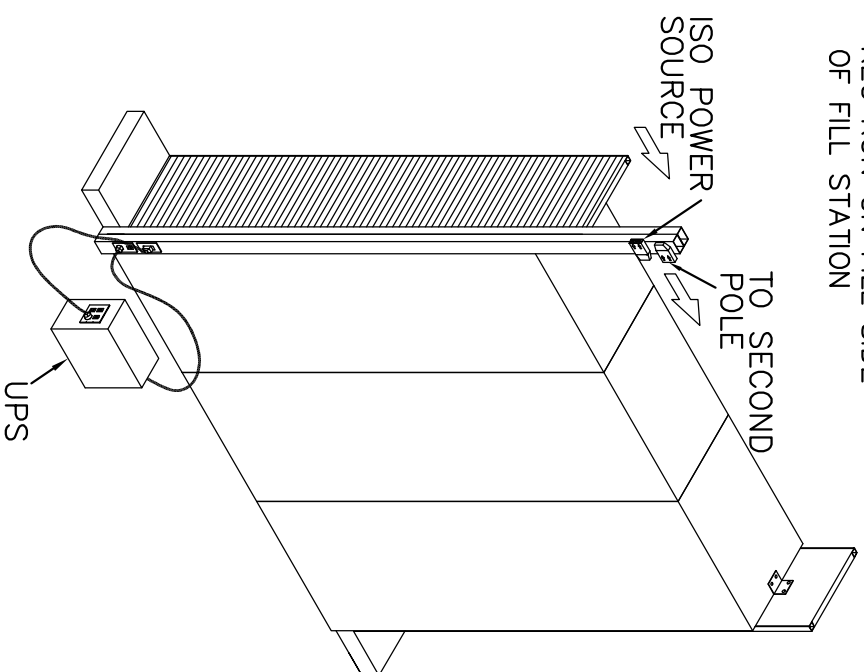

NOTE: ARROWS ADJACENT TO ELECTRICAL COMPONENTS INDICATE THE FLOW OF ELECTRICAL CURRENT. SEE SHEET A-6.1 FOR ELEVATION TAGS AND COMPONENT LOCATIONS.
QUESTIONS CONCERNING ELECTRICAL CONNECTIONS CALL UNIBER, 800-489-4882
NOTE: THIS EQUIPMENT IS FACTORY WIRE AND INCLUDED IN CONSTRUCTION PACKAGE FOR CONTRACTOR/OWNER'S CONVENIENCE. ENGINEER'S SEAL INDICATES ONLY GENERAL INTENT OF MODULAR SYSTEM. INSTALL EQUIPMENT IN COMPLIANCE WITH THE N.E.C., STATE AND LOCAL CODES.

2 ELEVATION VIEW
A-6.1 N.T.S.
REG RUN ON WORKBENCH

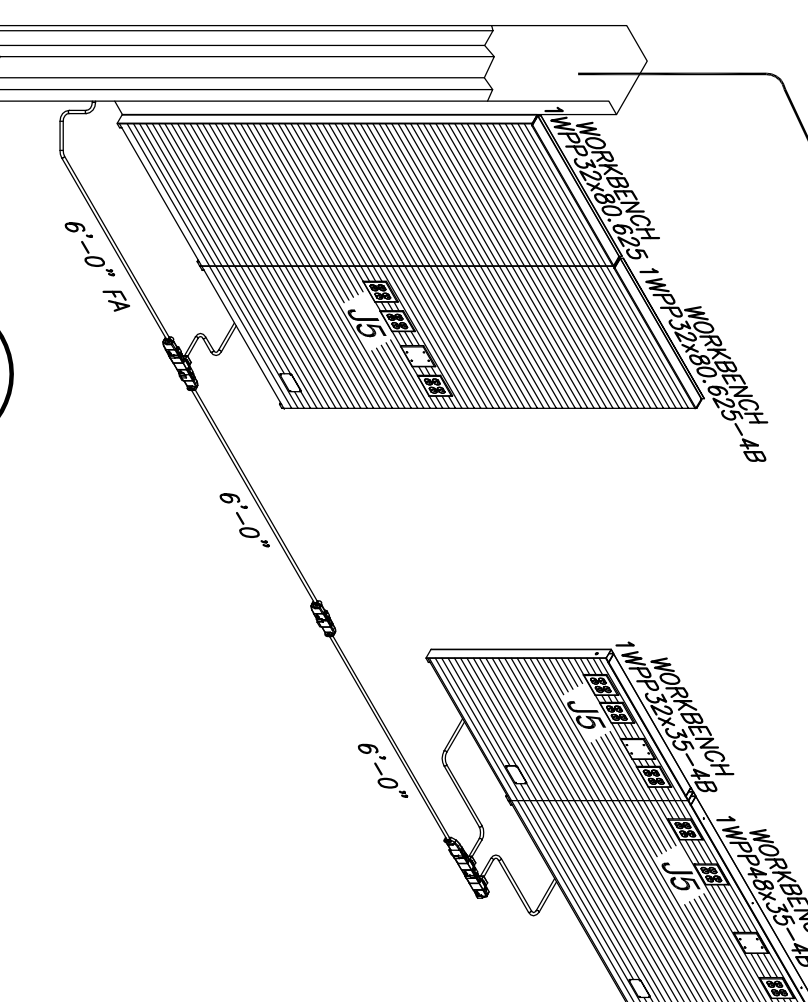

J & *J5* RUN ON WORKBENCH

5 ELEVATION VIEW
A-6.1 N.T.S.
UPS CONNECTIONS ON FILL SIDE OF FILL STATION

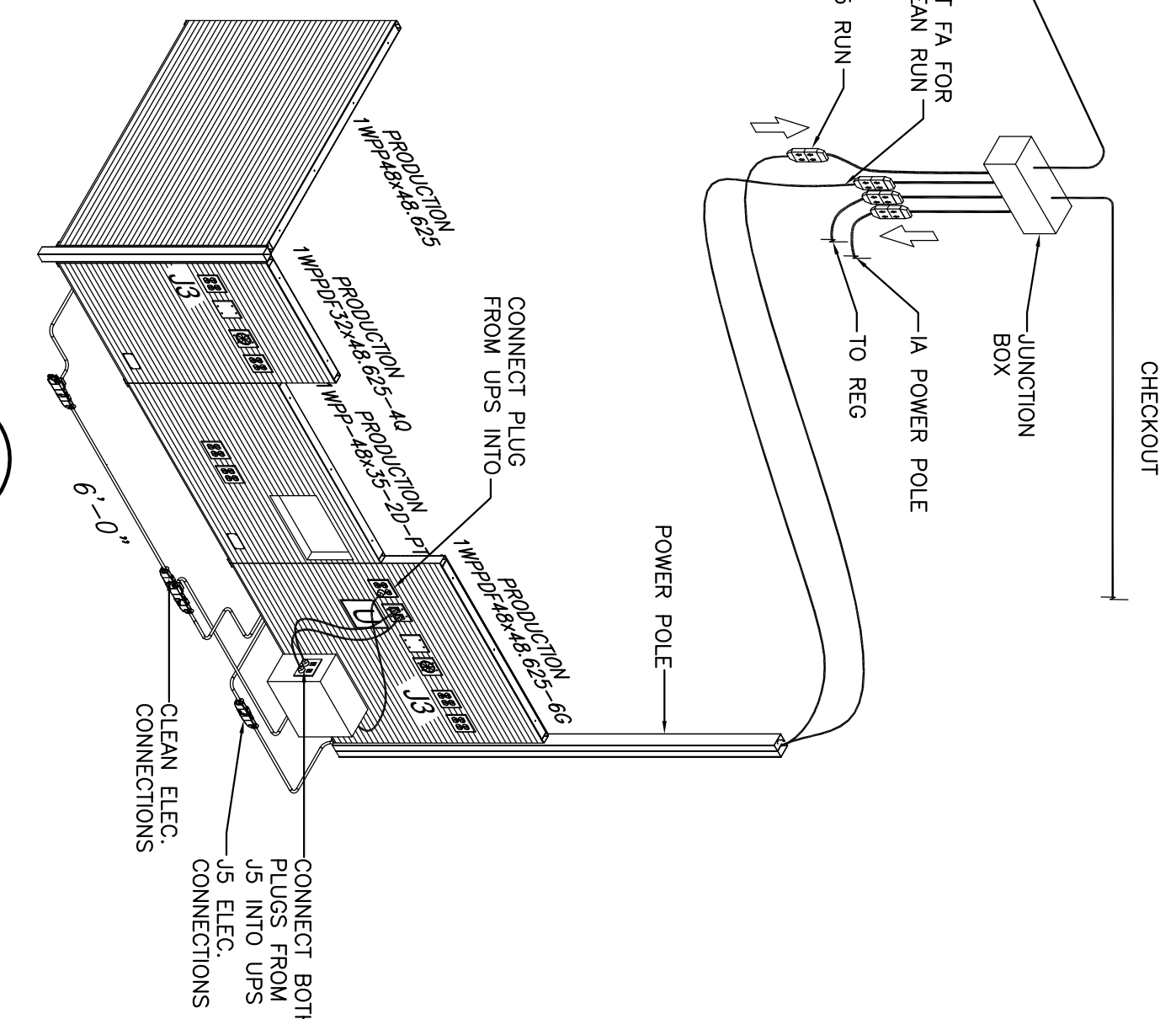

Copyright © 2008 by BKA Architects, Inc. The architectural plans, drawings, design, specifications and other arrangements on this sheet are and shall remain the property of BKA Architects, Inc. No part thereof shall be copied, disclosed to others, or used in connection with any work or project, other than the specified project for which they have been prepared and developed, without the express knowledge and written consent of BKA Architects, Inc.

DEVELOPER:
A & D REALTY, LLC
5 MILITIA DRIVE
LEWINGTON, MA 02421

NEW STORE NUMBER: 329
NORRIS PLAZA
91 AUBURN STREET
PORTLAND, MAINE

CONSULTANT:
R. W. Silliman Engineering
1100 N. Main Street, Suite 200
Portland, ME 04102
Phone: 603.233.2277 Fax: 603.233.2816
www.rwsilliman.com

SEAL:

UNIBER PHARMACY POWER INSTALLATION
SHEET NUMBER: E-1.4
ISSUED FOR CONSTRUCTION

REVISIONS:

DATE: 8/31/09
DRAWING BY: HYZ
JOB NUMBER: 209017

**142 Crescent Street
Brockton, MA 02302**
tel: 508.583.5003
fax: 508.584.2914
e-mail: bka@bkaarch.com

BKA Architects, Inc.
Architecture + Interiors