

IT IS IMPERATIVE THAT THE CONDITIONED AIR AT THE RETAIL LEVEL NOT MIX WITH THE UNCONDITIONED AIR IN THE ATTIC. G.C. SHALL MAKE SEVERAL VISUAL INSPECTIONS & SEAL ANY BREACHES. AND PROVIDE BATT INSULATION ALONG THE HORIZONTAL & VERTICAL PLANS OF THIS ENVELOPE (I.E. IN THE ATTIC, AT THE V.R.C.)

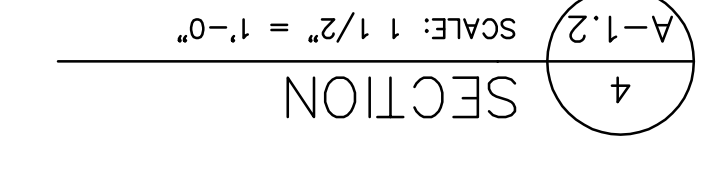
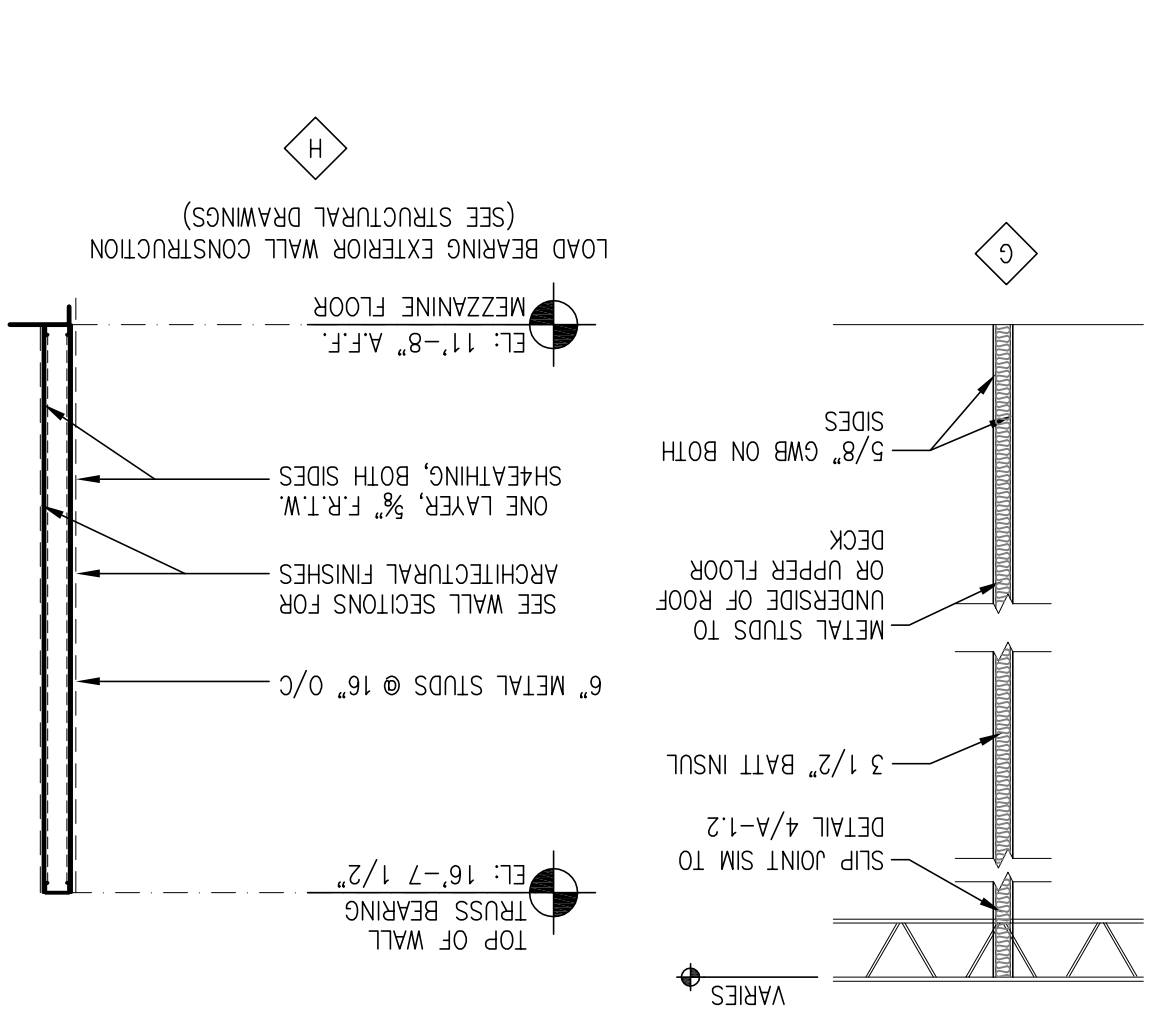
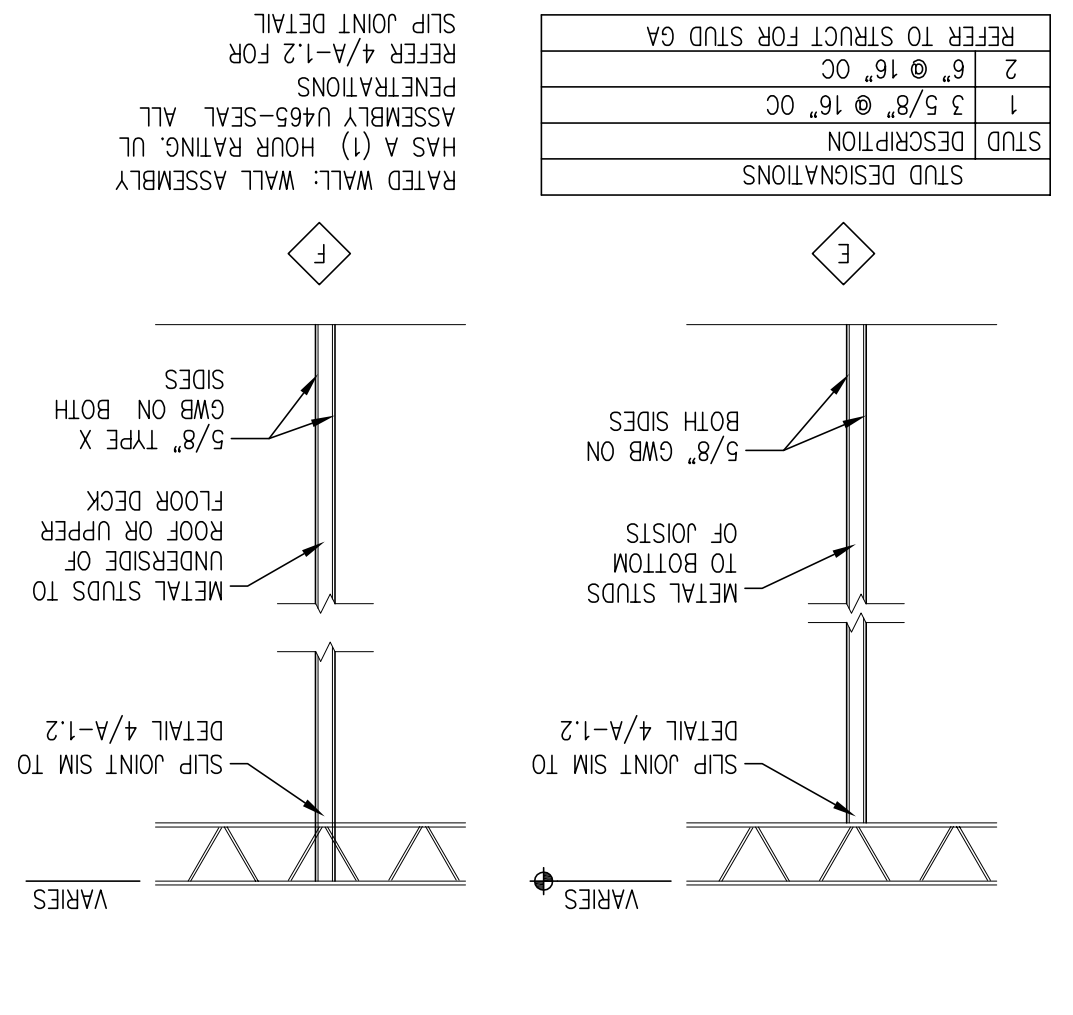
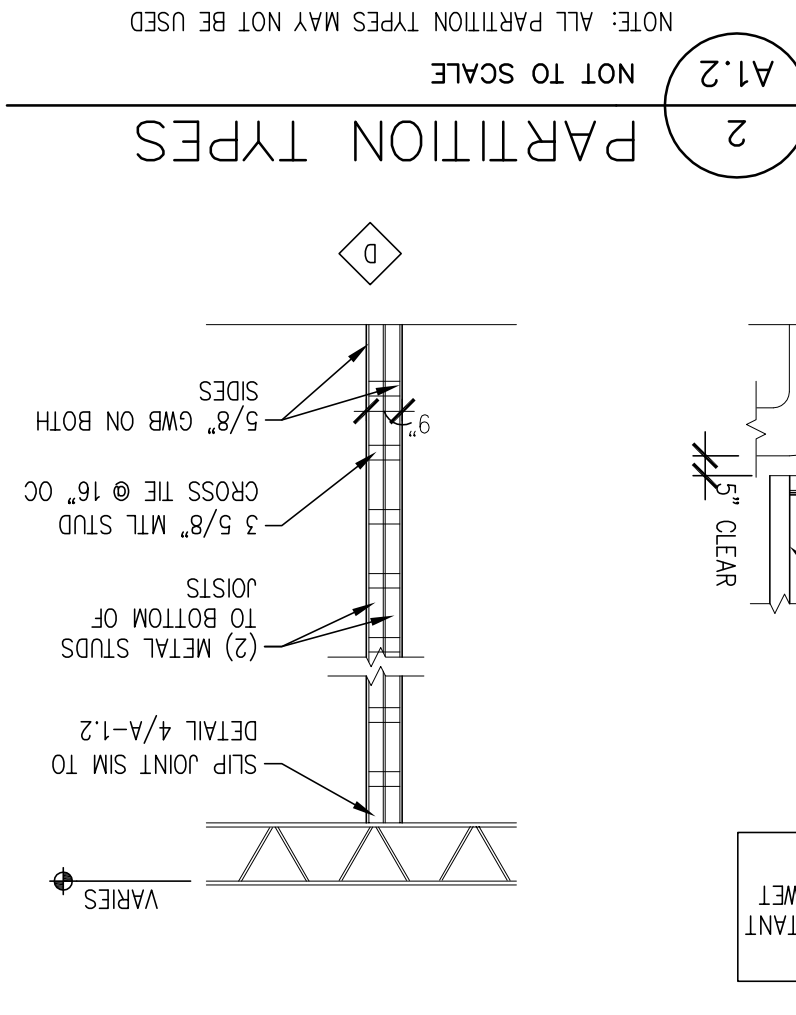
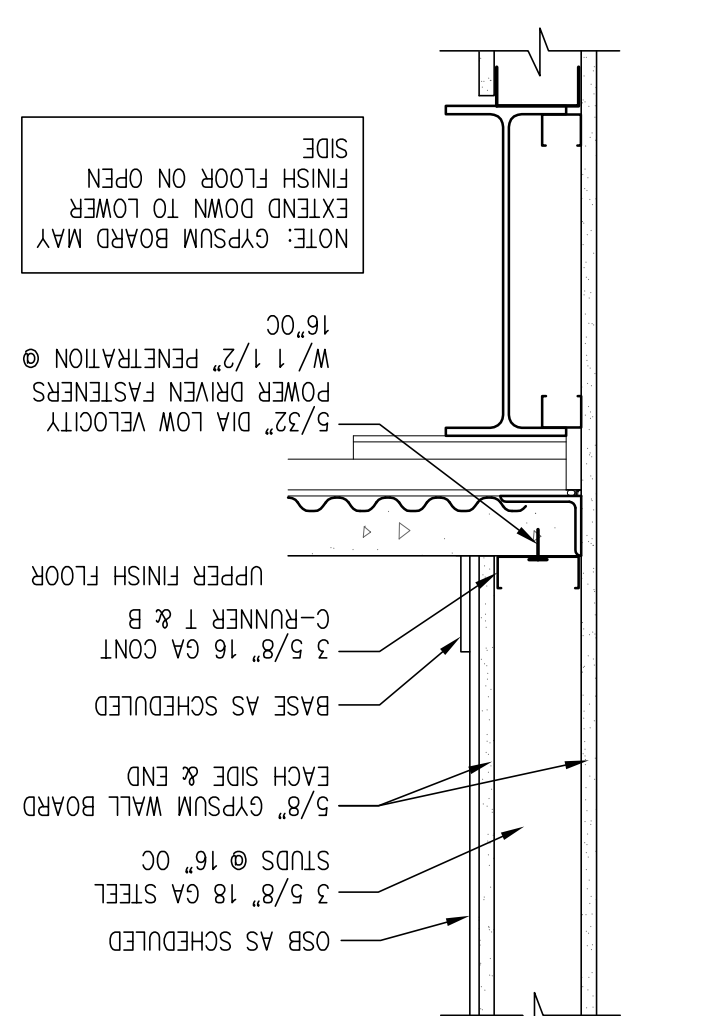
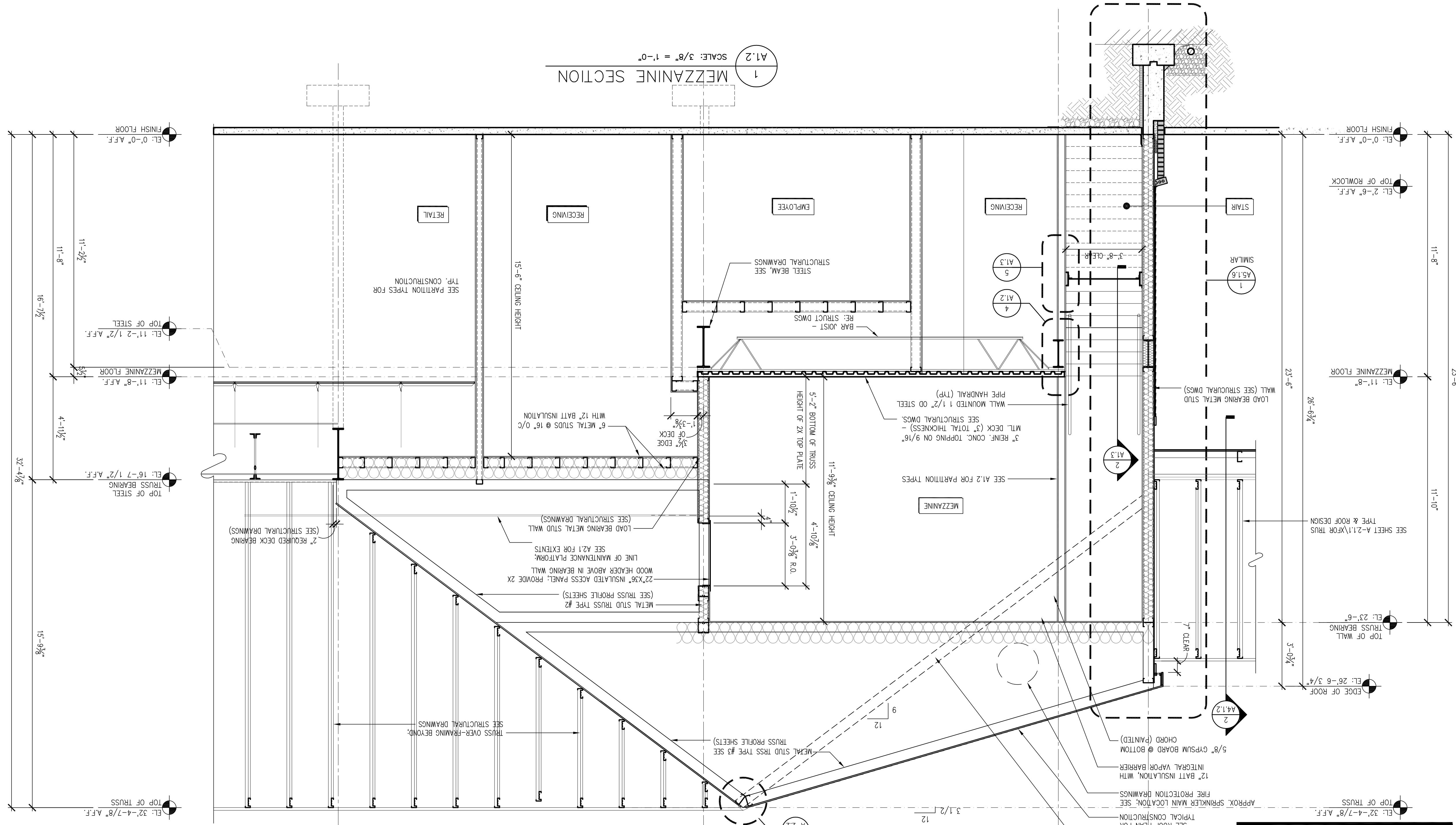

BKA Architects, Inc. Architecture + Interiors
 142 Crescent Street
 Brockton, MA 02302
 Tel: 508.583.5603
 Fax: 508.584.2914
 Email: bka@bkaarch.com

CONSULTANT:

NEW STORE NUMBER: 329
 NORTHGATE PLAZA
 91 AUBURN STREET
 PORTLAND, MAINE

DEVELOPER:
 A & D REALTY, LLC
 5 MILITIA DRIVE
 LEXINGTON, MA 02421

REVISIONS:

NO.	DATE	BY	DESCRIPTION
1	8/31/09	RTK	

JOB NUMBER: 209017
 TITLE: MEZZANINE SECTION & DETAILS
 SHEET NUMBER: A-1.2
 COMMENTS: ISSUED FOR CONSTRUCTION