

TELLER SECTION

SCALE: 1/2" = 1'-0"

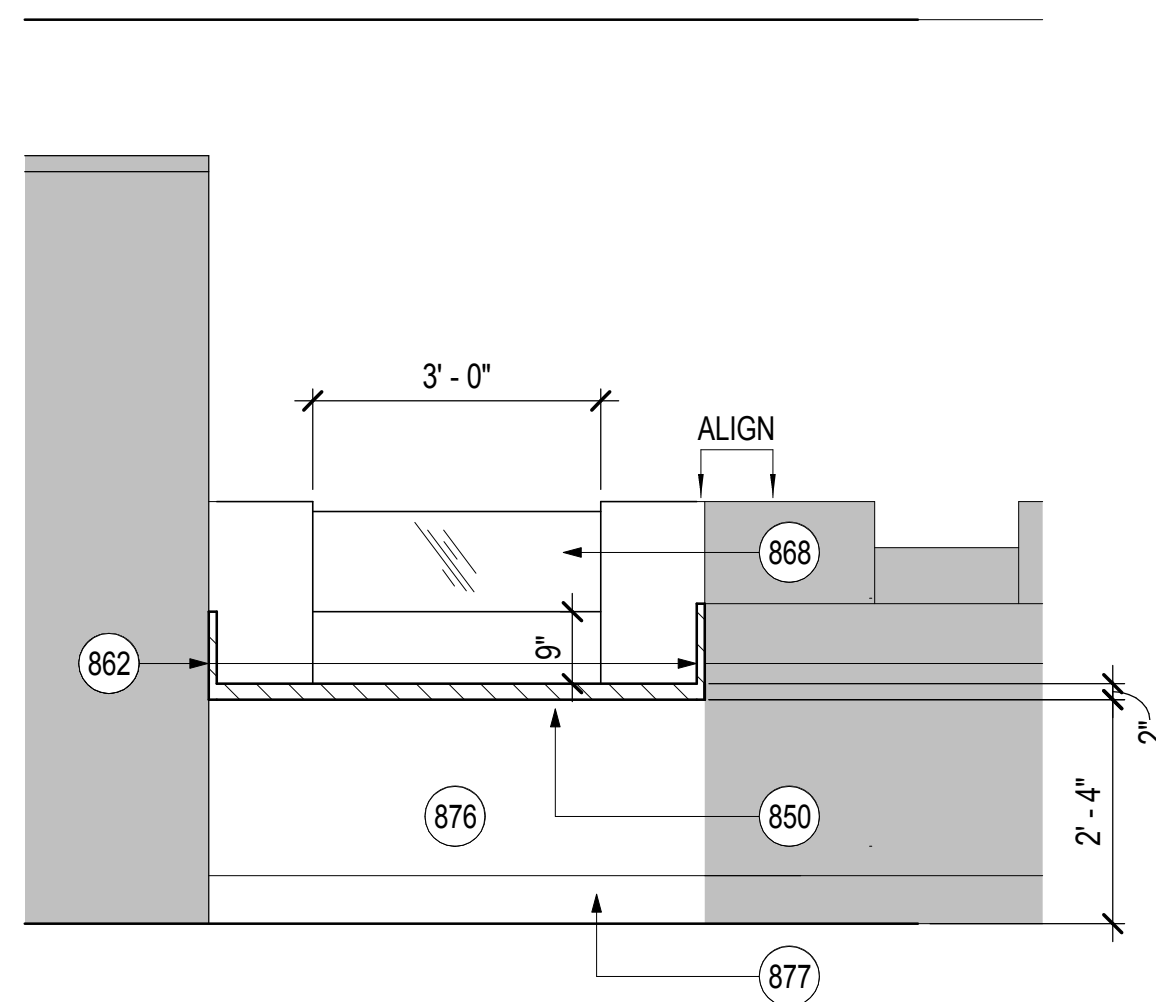

TELLER ELEVATION - CUSTOMER SIDE

SCALE: 1/2" = 1'-0"

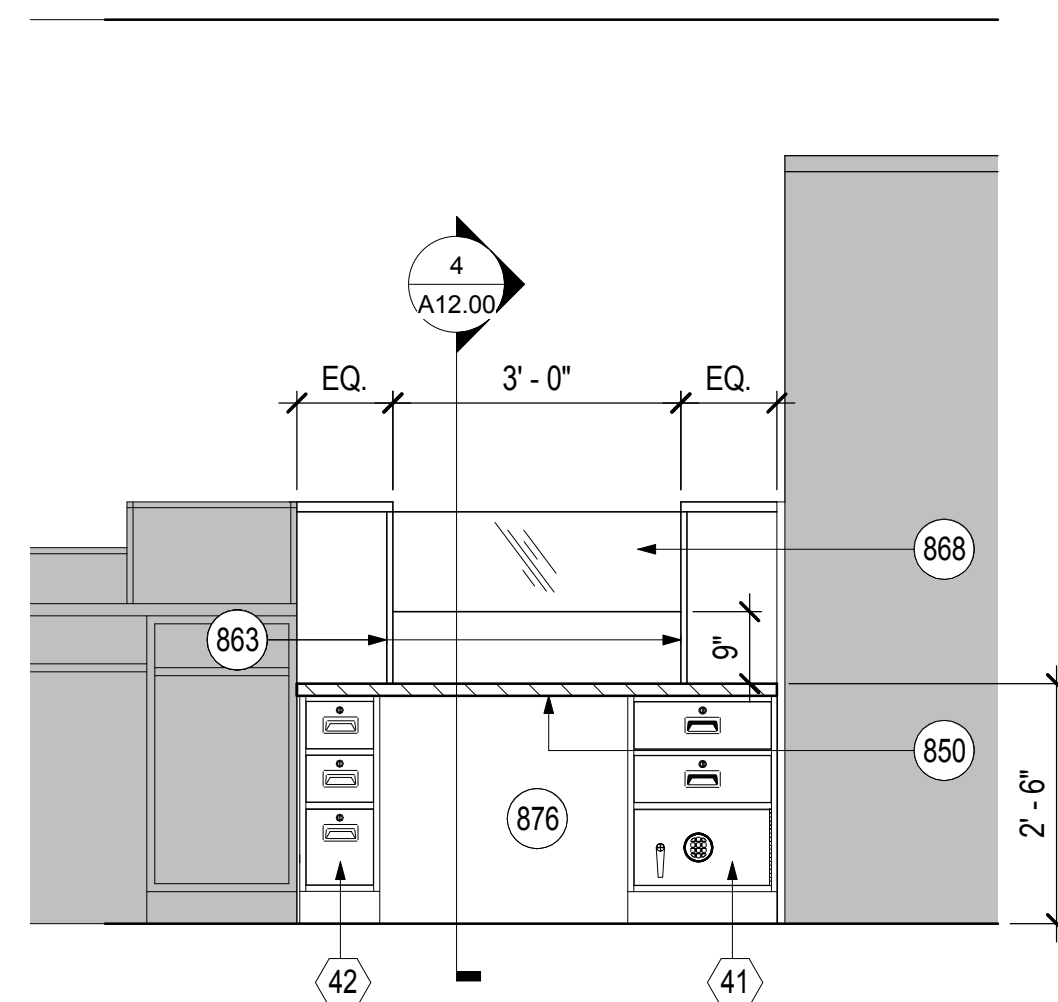

TELLER ELEVATION - TELLER SIDE

SCALE: 1/2" = 1'-0"

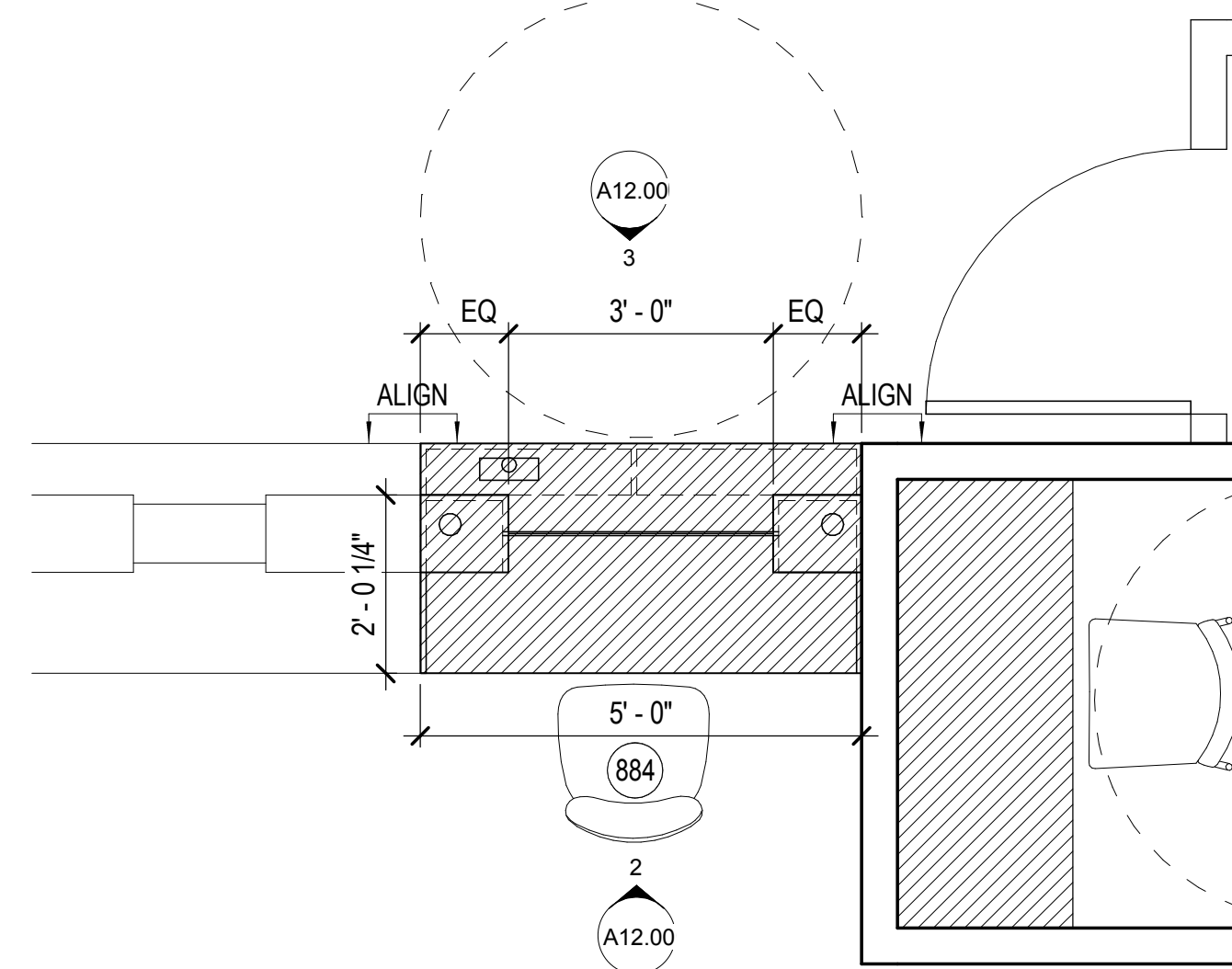

ENLARGED TELLER PLAN

SCALE: 1/2" = 1'-0"

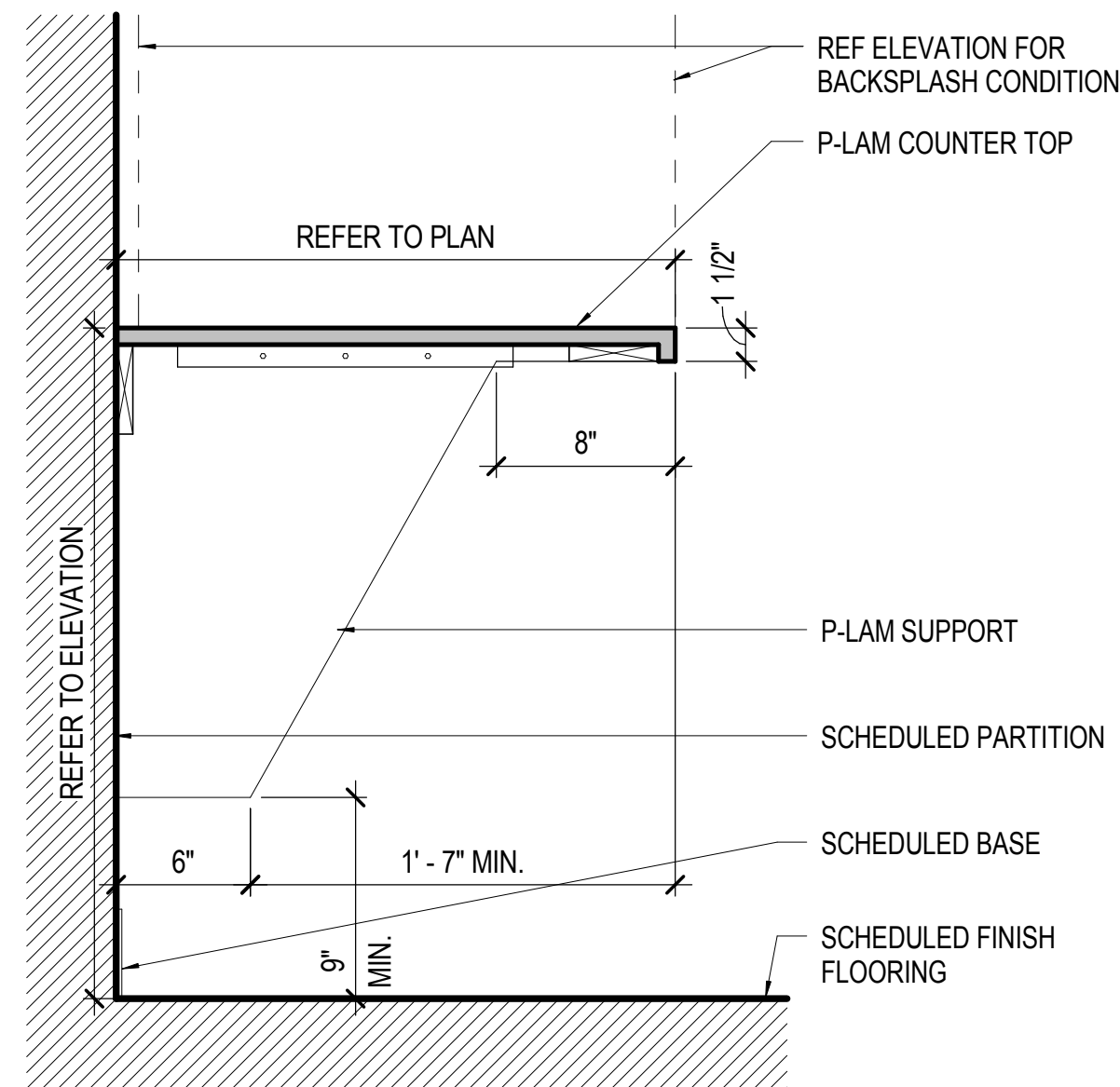

ADA COUNTER SECTION

SCALE: 1 1/2" = 1'-0"

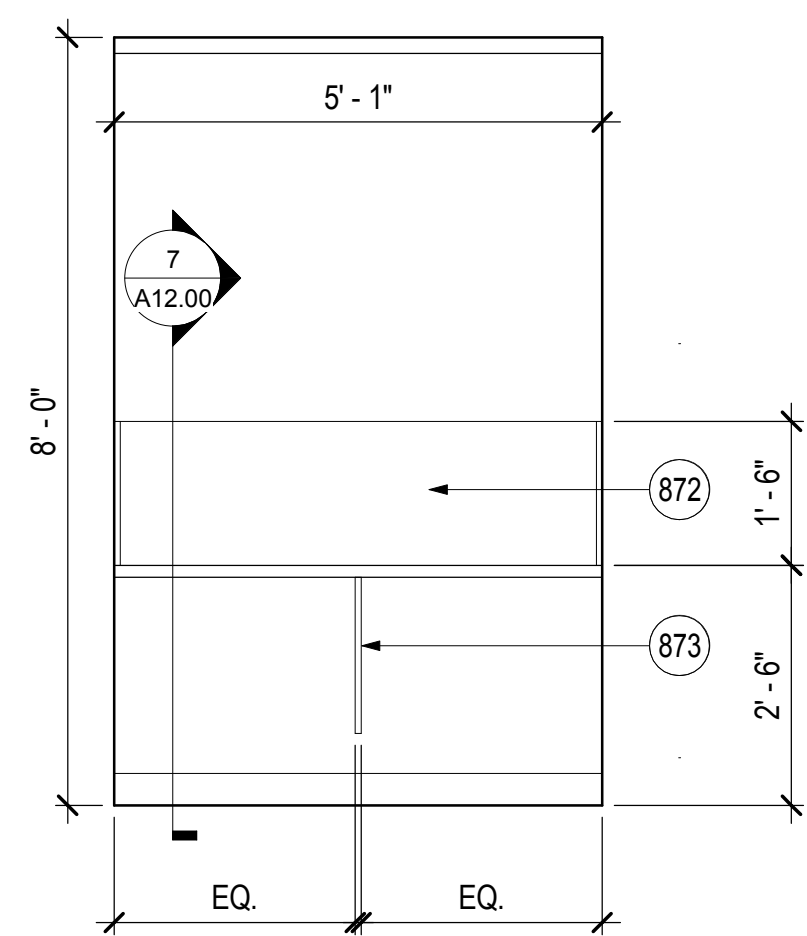

COUPON BOOTH ELEVATION

SCALE: 1/2" = 1'-0"

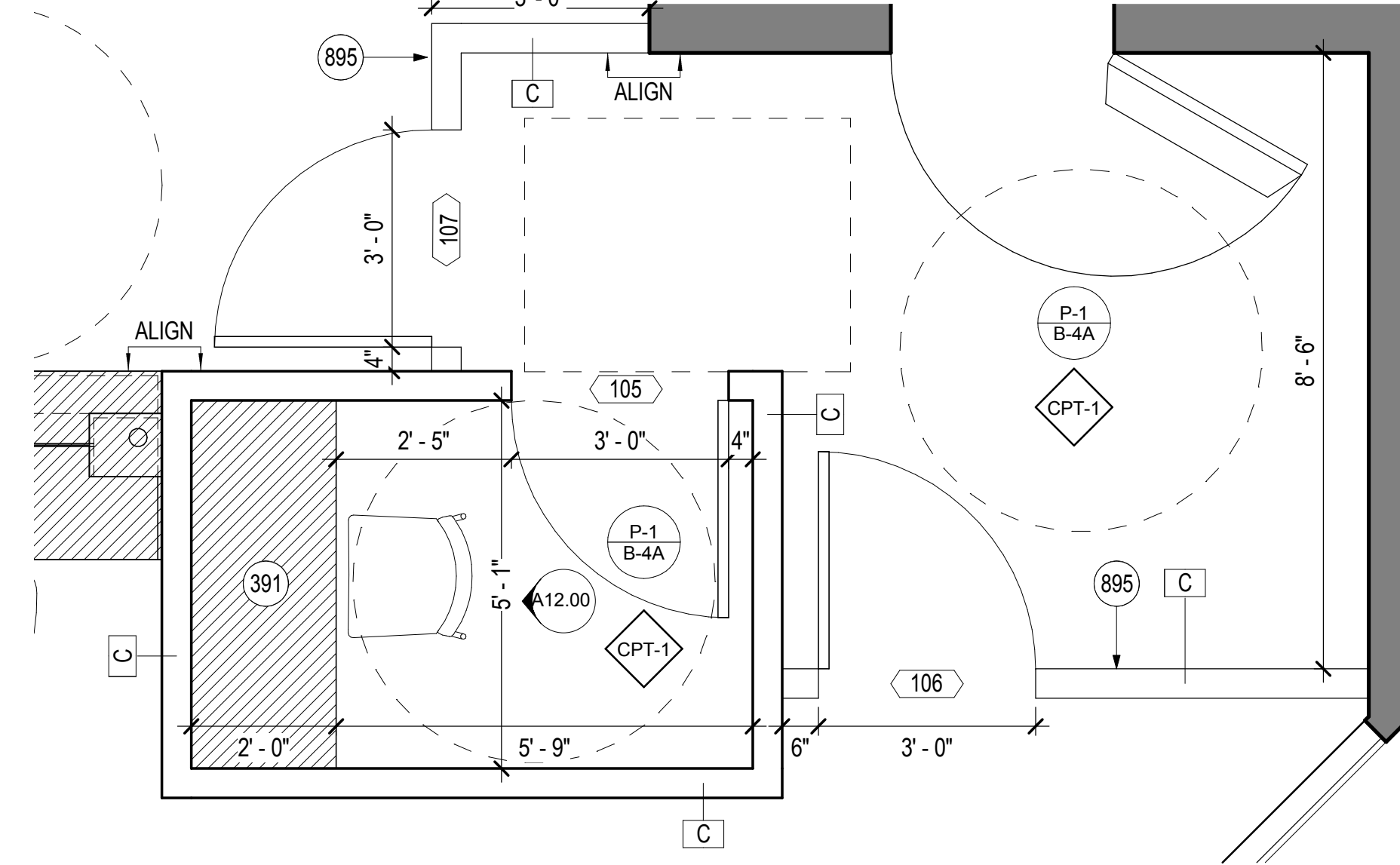

ENLARGED COUPON BOOTH PLAN

SCALE: 1/2" = 1'-0"

MARK	DESCRIPTION	MANUFACTURER/MODEL
40		DIEBOLD MODEL:SD-3-LL (PT#00-022047-L-00)
41		DIEBOLD MODEL:SD-3-RL (PT#00-022047-R-00)
42		DIEBOLD MODEL: 10" ADA STORAGE PEDESTAL (PT#41-018855-000-C)
43		INGENICO PAYMENT TERMINAL AS PROVIDED BY OWNER

UNDER COUNTER STEEL EQUIPMENT TO BE PROVIDED BY OWNER AND INSTALLED BY G.C.

UNDERCOUNTER STEEL SCHEDULE

SCALE: 1/2" = 1'-0"

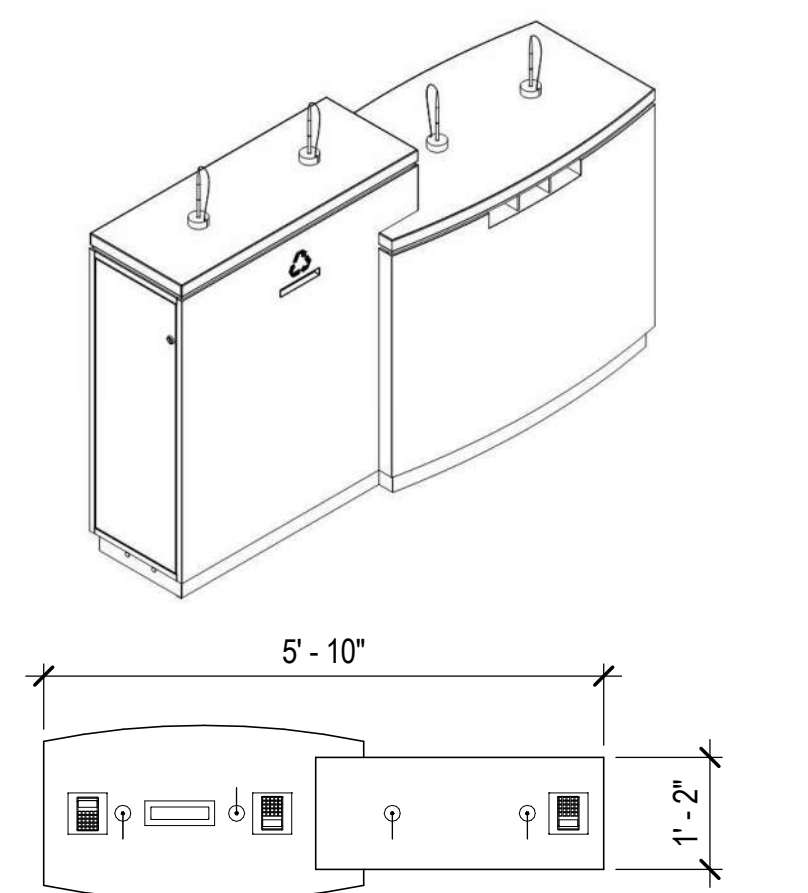

CHECK DESK TO BE PROVIDED BY OWNER AND INSTALLED BY G.C. IDX BMA50007 - STANDARD LOBBY CHECK DESK

CHECK DESK - LOBBY

SCALE: 1/2" = 1'-0"

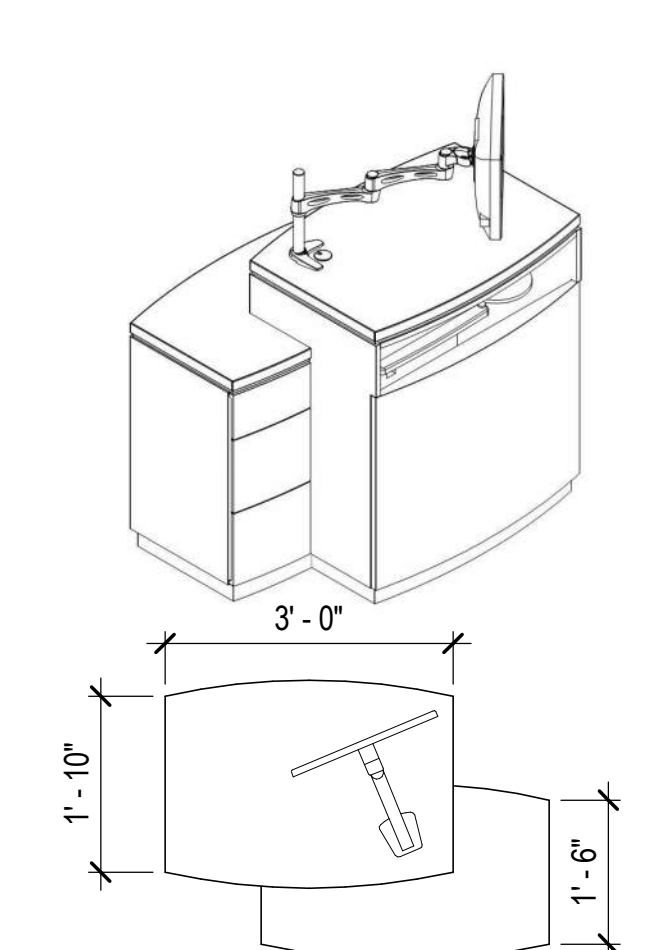

CHECK DESK TO BE PROVIDED BY OWNER AND INSTALLED BY G.C. IDX BMA50003 - UNIVERSAL HOST WORK STATION

CHECK DESK - HOST WORK STATION

SCALE: 1/2" = 1'-0"

KEY NOTES

- 391 NEW COUPON BOOTH COUNTER.
- 850 NEW ADA TELLER COUNTER (W/ LOWERED CUSTOMER SHELF) FINISHES TO MATCH EXISTING. VERIFY W/ OWNER & ARCHITECT PRIOR TO INSTALLATION. RELOCATE ALL POWER/DATA, PAYMENT TERMINAL AND SECURITY DEVICES IF EXISTING TO SAME LOCATION. CONFIRM FINAL LOCATIONS WITH OWNER.
- 862 NEW VERTICAL MILLWORK PANEL TO CONNECT NEW LOWERED COUNTER TO EXISTING COUNTER TO REMAIN. ALL EXPOSED SURFACES TO BE FINISHED TO MATCH EXISTING.
- 863 NEW VERTICAL END PANEL. FINISH TO MATCH EXISTING.
- 868 1/2" CLEAR ACRYLIC WITH POLISHED EDGES. INSTALL ACRYLIC SCREEN WITH 2 SATIN ALUM. CHANNELS (LEFT AND RIGHT). RECESS INTO EXISTING MILLWORK AND SET ACRYLIC INTO CHANNEL WITH CLEAR SILICONE.
- 872 COUNTERTOP, BACKSPASH AND SIDE SPLASH BOTH SIDES TO BE PL-8 FINISH. COUNTERTOP SUPPORT TO BE PL-7 FINISH.
- 876 NEW FINISHES TO MATCH EXISTING.
- 877 NEW BASE TO MATCH EXISTING.
- 884 NEW CH-50 ADA TELLER CHAIR BY STEELCASE (#TS30102).
- 895 NEW 'C' TYPE WALL TO BE 4'-3" HT.

GENERAL NOTES

- A. ALL INTERIOR OF MILLWORK TO BE WHITE MELAMINE, UNLESS NOTED OTHERWISE.
- B. ALL EXPOSED SURFACES OF MILLWORK TO BE PLASTIC LAMINATE AS SPECIFIED ON ELEVATIONS.
- C. REF. SHEET A00.40 FOR TYPICAL WALL MOUNTING HEIGHTS.
- D. CONTRACTOR TO COORDINATE ALL POWER AND COMMUNICATIONS AT TELLER COUNTER.
- E. CONTRACTOR SHALL PROVIDE BLOCKING PER ALL EQUIPMENT/ACCESSORIES MOUNTED ON WALL.
- F. ALL DEVICE COVER PLATES INCLUDING PLATES FOR COAX SHALL MATCH LUTRON LIGHT ALMOND UNLESS NOTED OTHERWISE.
- G. G.C. TO PROVIDE CAULK AROUND ALL UNDERCOUNTER STEEL AS REQUIRED. COLOR TO MATCH UNDERCOUNTER STEEL AS PROVIDED.
- H. G.C. SHALL PROVIDE ALL WORK RELATED TO ENGINEERING TO INCLUDE, BUT NOT LIMITED TO: MECHANICAL, ELECTRICAL, FIRE PROTECTION & LIFE SAFETY. G.C. SHALL PROVIDE DESIGN DRAWINGS, PERMITS & INSTALLATION OF SYSTEMS ON A DESIGN BUILD BASIS.
- I. FOR FINISH SCHEDULE, REFER A00.20
- J. WHEN A GAP EXISTS BETWEEN THE TOP OF THE UNDERCOUNTER STEEL AND THE UNDERSIDE OF THE COUNTER, G.C. TO BUILD A 1" MILLWORK BASE TO MATCH EXISTING FINISH AND CONSTRUCTION.
- K. ALL SECURITY DEVICES AND SYSTEMS TO REMAIN INTACT DURING ALL PHASES OF WORK. ANY MODIFICATIONS NEEDED DUE TO AREA OF DEMOLITION AND NEW CONSTRUCTION LAYOUT TO BE PERFORMED BY OWNER'S SECURITY VENDOR AND TO BE COORDINATED WITH OWNER PRIOR TO DEMOLITION.

Issue #	Issue Date	Issue Description
1	08/15/2014	ISSUE FOR BID AND PERMIT

Seal/Signature _____

Project Name
ADA UPGRADES

Project Number
11.6560.125

Description
ENLARGED PLANS AND TYPICAL DETAILS

Scale
As indicated

A12.00