

No.	Location	Type	Door			Material	Finish	Frame			Fire Rating	Hardware Set	Remarks	
			Width	Height	Thickness			Head	Jamb	Sill				
100	ATM VESTIBULE	G	MATCH EX.	MATCH EX.	MATCH EX.	EX.	EX.	EX.	EX.	EX.	EX.	#AL-1	EXISTING CARD READER TO REMAIN	
101	ATM VESTIBULE	G	MATCH EX.	MATCH EX.	MATCH EX.	EX.	EX.	EX.	EX.	EX.	EX.	#AL-1		
105	SVB VIEWING ROOM	A	3'-0"	7'-0"	1 3/4"	WOOD	P-2	--	--	--	WOOD	P-2	#6	
106	SDB VESTIBULE	A1	3'-0"	4'-5"	1 3/4"	WOOD	P-2	--	--	--	WOOD	P-2	#6C	
107	SECURED TELLER AREA	A1	3'-0"	4'-5"	1 3/4"	WOOD	P-2	--	--	--	WOOD	P-2	#11A	DOOR EXISTING TO REMAIN. PROVIDE NEW HDWR.
108	OFFICE	EX.	EX.	EX.	EX.	EX.	EX.	EX.	EX.	EX.	EX.	#5B	DOOR EXISTING TO REMAIN. PROVIDE NEW HDWR.	
110	OFFICE	EX.	EX.	EX.	EX.	EX.	EX.	EX.	EX.	EX.	EX.	#5B	DOOR EXISTING TO REMAIN. PROVIDE NEW HDWR.	
111	EGREES DOOR	EX.	EX.	EX.	EX.	EX.	EX.	EX.	EX.	EX.	EX.	AL-1C	G.C. TO COORDINATE HARDWARE REPLACEMENT WITH SECURITY VENDOR	

DOOR SCHEDULE

SCALE: 1/2" = 1'-0"

QTY	DESCRIPTION	MODEL	FINISH	MFR
GROUP 6 - COUPON BOOTH				
3 EA	HINGE	BB1279 4.5 X 4.5	26D	HAG
1 EA	PRIVACY SET	ND40S SPA	626	SCH
1 EA	WALL STOP	WS407CCV	630	IVE
3 EA	SILENCER	SR64	GRY	IVE

QTY	DESCRIPTION	MODEL	FINISH	MFR
GROUP 6C - VIEWING AREA				
2 EA	HINGE	BB1279 4.5 X 4.5	26D	HAG
1 EA	ELECTRIFIED LOCK	ND96PDEU SPA	626	SCH
1 EA	SFIC EV B CORE ONLY	80-037	626	SCH
1 EA	WALL STOP	WS407CCV	630	IVE
2 EA	SILENCER	SR64	GRY	IVE

QTY	DESCRIPTION	MODEL	FINISH	MFR
GROUP AL-1C - VIEWING AREA				
1 EA	PANIC EXIT HARDWARE	98/99EL RIM EXT. DEVICE	630	VDN

QTY	DESCRIPTION	MODEL	FINISH	MFR
GROUP 5B - OFFICES				
3 EA	HINGE	BB1279 4.5 X 4.5	26D	HAG
1 EA	OFFICE LOCKSET	ND91PD F82	626	SCH
1 EA	WALL STOP	WS407CCV	630	IVE
3 EA	SILENCER	SR64	GRY	IVE

QTY	DESCRIPTION	MODEL	FINISH	MFR
GROUP 11A - SECURE TELLERS				
3 EA	HINGE	BB1279 4.5 X 4.5	26D	HAG
1 EA	STOREROOM LOCK	ND80HD SPA	626	SCH
1 EA	SURFACE CLOSER	4011	689	LCN
1 EA	WALL STOP	WS407CCV	630	IVE
3 EA	SILENCER	SR64	GRY	IVE

QTY	DESCRIPTION	MODEL	FINISH	MFR
GROUP AL-1 - STOREFRONT (EXTERIOR DOOR)				
4 EA	HINGE	BB1199 4.5 X 4.5 NRP	26D	HAG
1 EA	PANIC EXIT HARDWARE	98/99EL RIM EXT. DEVICE	630	VDN
1 EA	DOOR PULL	8103EZ-0	630	IVE
1 EA	MORTISE CYLINDER	80-132XQ110948	626	SCH
1 EA	DEADLOCK	MS1850S	626	AR
1 EA	RIM CYL W/CONST CORE	80-159	626	SCH
1 EA	SURFACE CLOSER	4110 SCUSH	689	LCN
1 EA	MOUNTING PLATE	4110-18	689	LCN
1 EA	CUSH SHOE SUPPORT	4110-30	689	LCN
1 EA	BLADE STOP SPACER	4110-61	689	LCN
1 EA	THRESHOLD	325	689	NGP
1 EA	CARD READER	INSTALLED BY BANK SECURITY VENDOR		

HARDWARE SCHEDULE

SCALE: 1/2" = 1'-0"

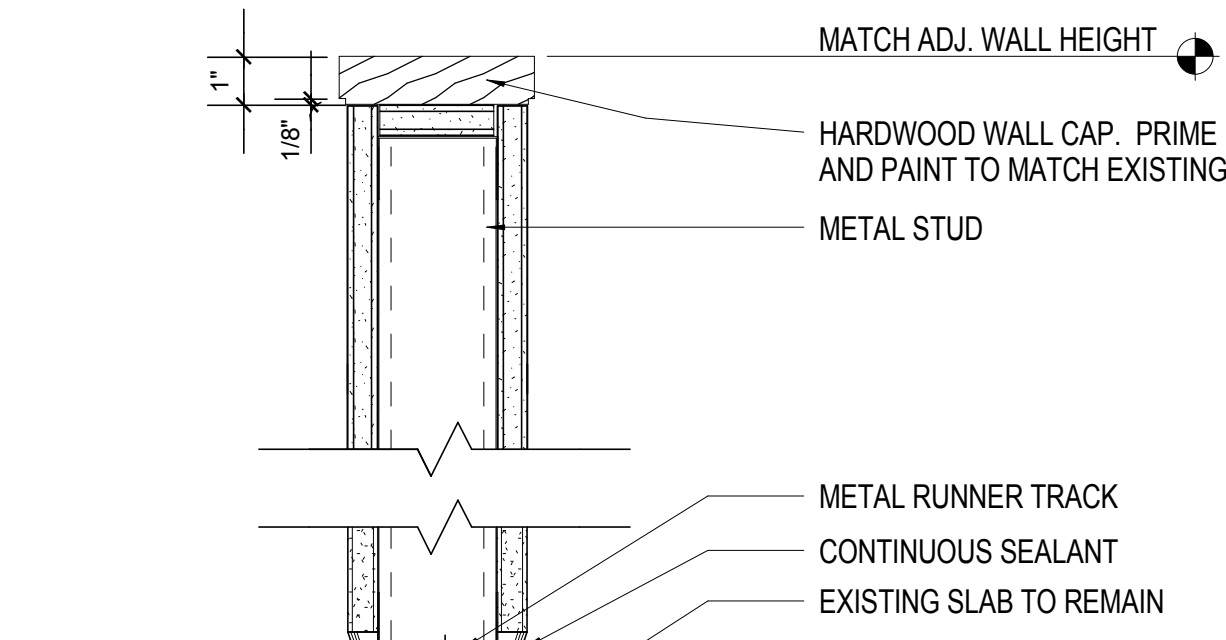
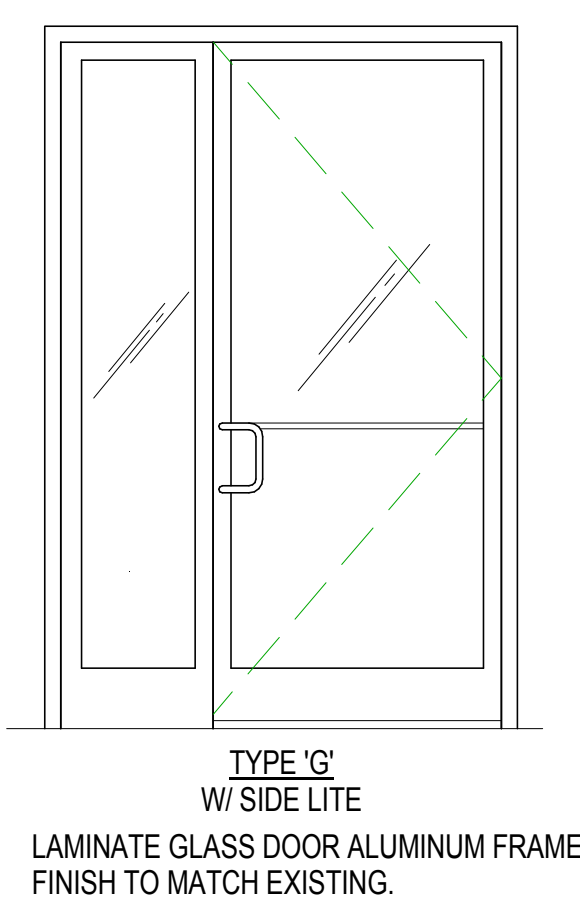
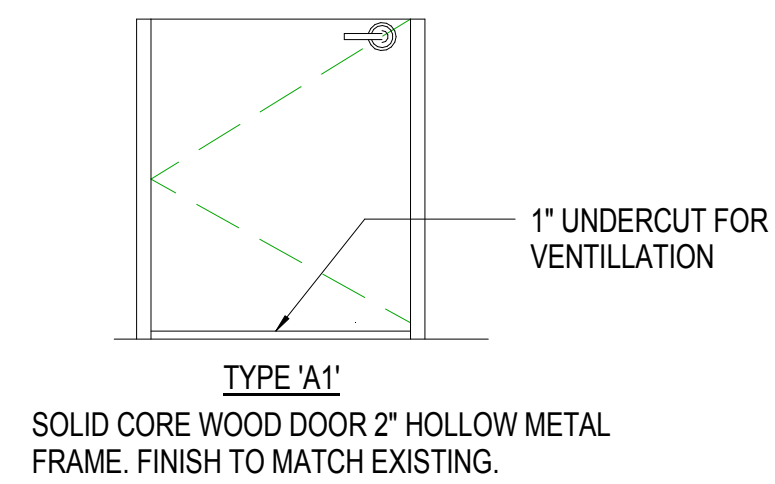
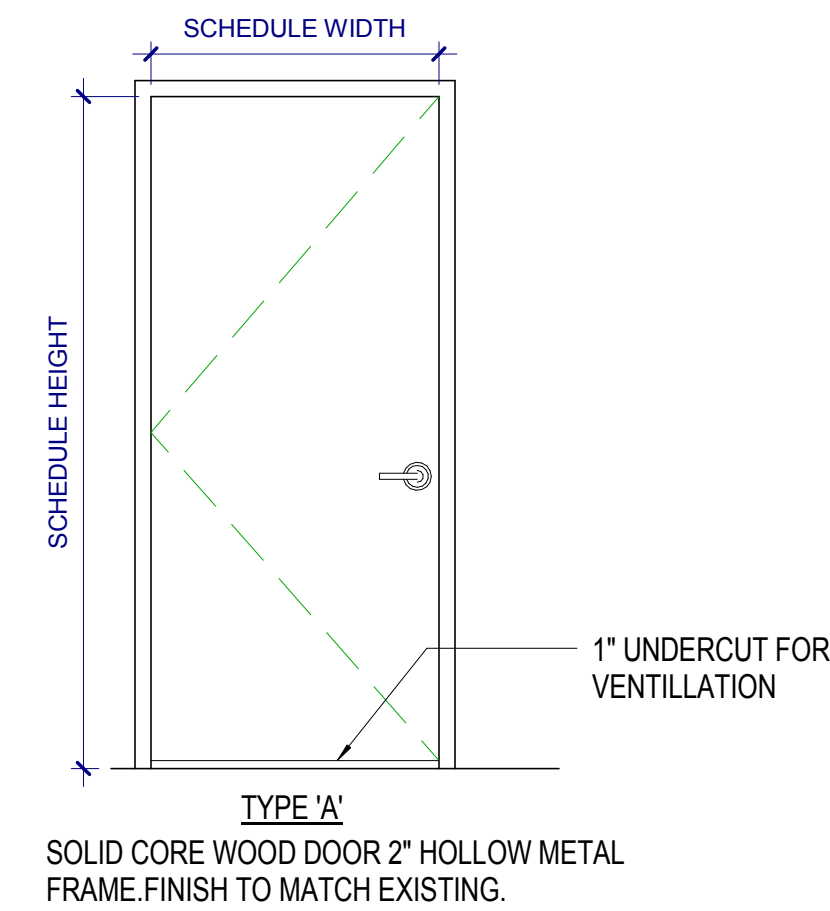

NUMBER	STUD SIZE	SEE SPEC	SEE SPEC	GYPSUM BOARD	WALL THICKNESS	INSULAT.	FIRE RATING	U.L. NUMBER	S.T.C. RATING
C	3 5/8"			5/8"	4 7/8"				

PARTITION TYPE C

SCALE: 3/4" = 1'-0"

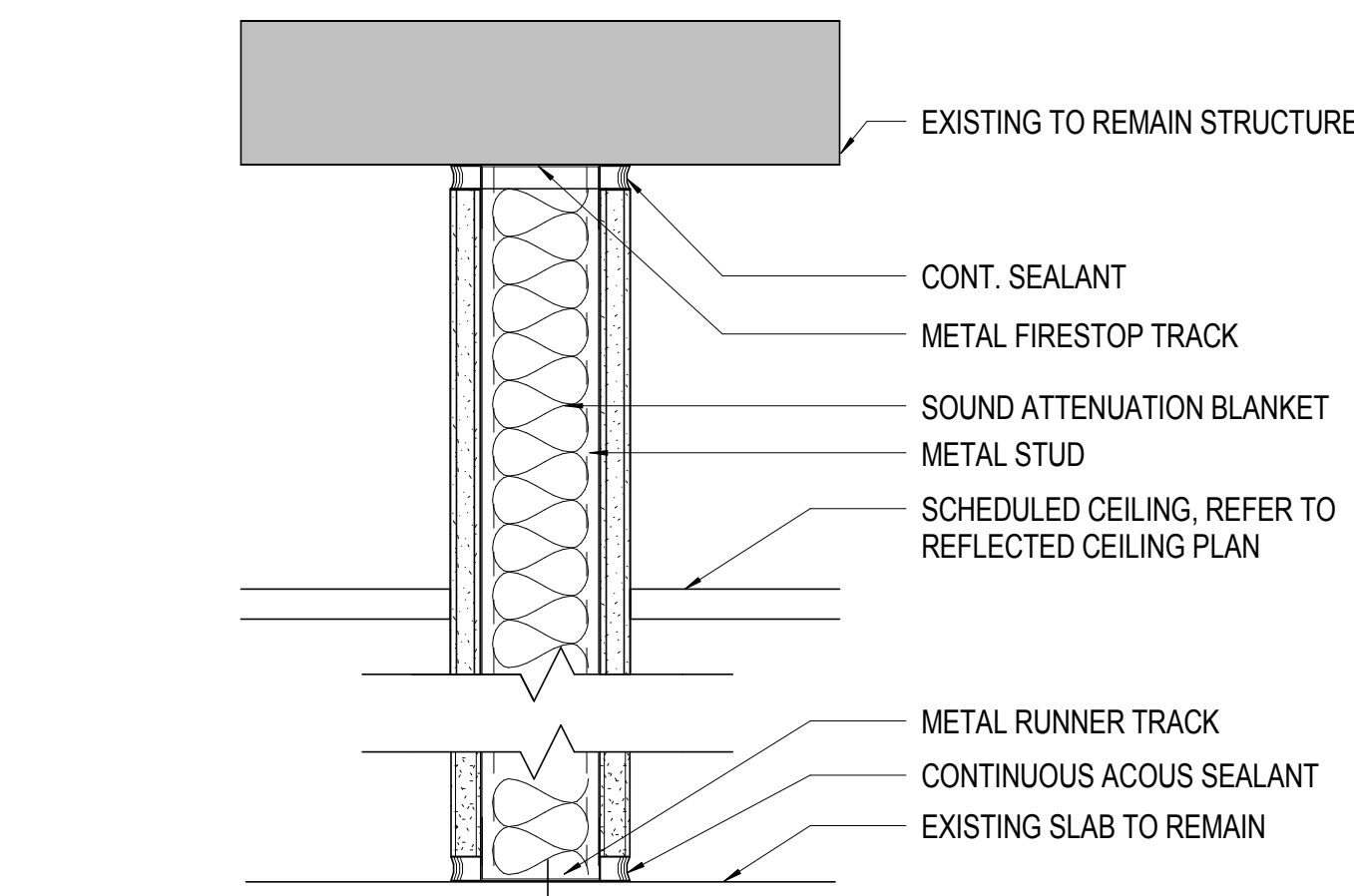
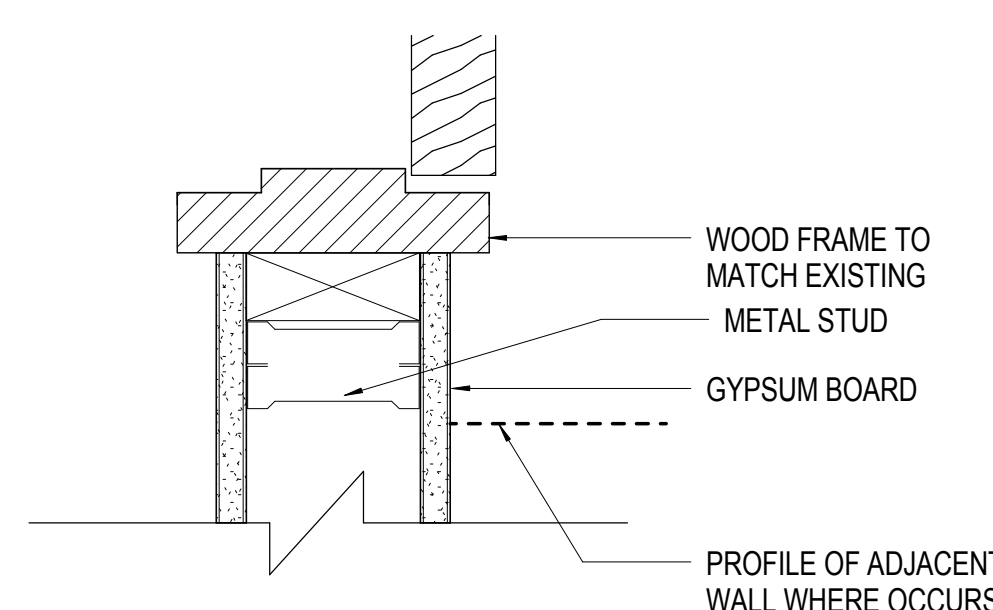

NUMBER	STUD SIZE	SEE SPEC	SEE SPEC	GYPSUM BOARD	WALL THICKNESS	INSULAT.	FIRE RATING	U.L. NUMBER	S.T.C. RATING
A	3 5/8"			5/8"	4 7/8"				

PARTITION TYPE A

SCALE: 3/4" = 1'-0"

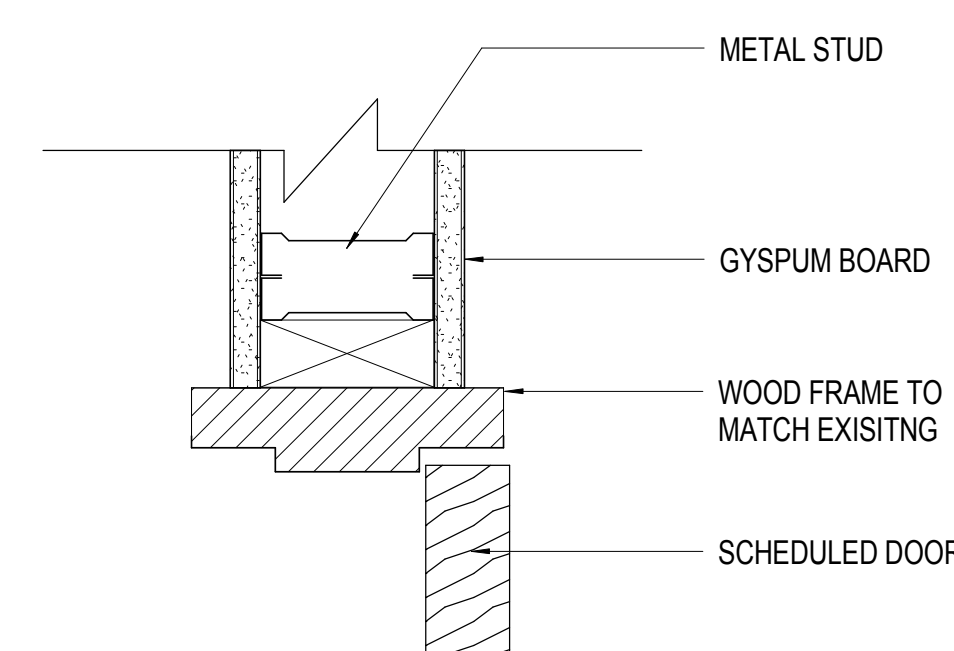

DOOR TYPES

SCALE: 1/2" = 1'-0"

WOOD DOOR FRAME TYP. JAMB

SCALE: 3/4" = 1'-0"

WOOD DOOR FRAME TYP. HEAD

SCALE: 3/4" = 1'-0"

KEY NOTES

GENERAL NOTES

- COORDINATE ALL HARDWARE WITH DOOR SWINGS. WHEN SPECIFIED, CLOSERS TO BE ON INTERIOR OF ALL ROOMS. IF NO WALL IS PROVIDED WHERE A WALL STOP HAS BEEN SPECIFIED, SUBMIT OVERHEAD STOP WITH HARDWARE SUBMITTAL. ALL SECURITY HARDWARE TO BE LOCATED SO THE INTERIOR ROOM OR SPACE IS SECURE, U.N.O.
- ALL HARDWARE FINISH TO MATCH EXISTING, U.N.O. WHERE MULTIPLE FINISHES EXIST, NOTIFY ARCHITECT IMMEDIATELY AND CONFIRM FINAL FINISH SELECTION BEFORE ORDERING.
- WHERE NEW HARDWARE IS TO BE INSTALLED ON EXISTING DOORS, CONFIRM ALL SPECIFIED HARDWARE IS COMPATIBLE WITH EACH DOOR TYPE. NOTIFY ARCHITECT OF ALL CONFLICTS BEFORE ORDERING.

Issue #	Issue Date	Issue Description
1	08/15/2014	ISSUE FOR BID AND PERMIT

Seal/Signature

Project Name
ADA UPGRADES

Project Number
11.6560.125

Description
PARTITION TYPES, DOOR & HARDWARE SCHEDULES

Scale
NOT TO SCALE

A00.20

© 2014 Gensler