

3 BUILDING SECTION

1/4" = 1'-0"

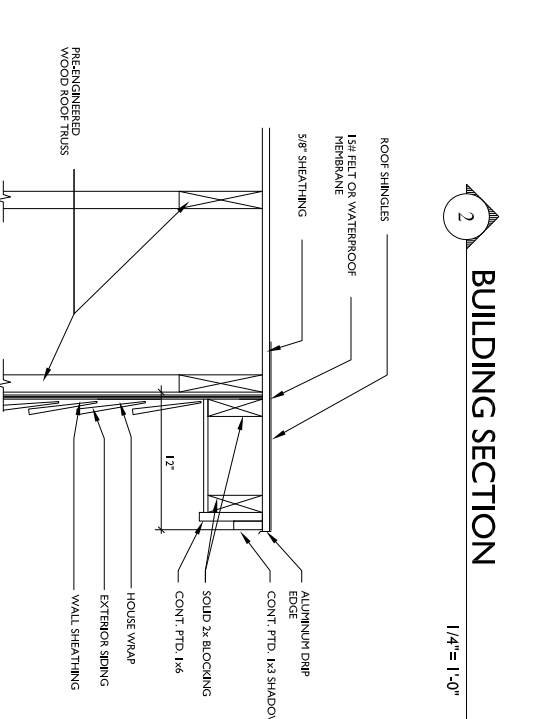
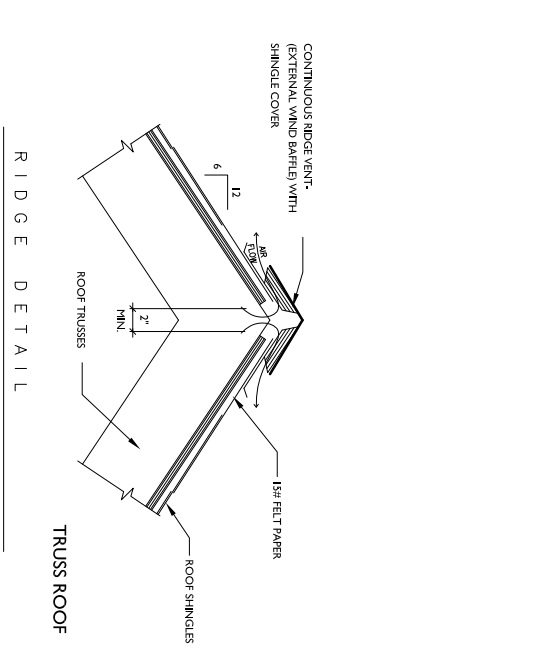

ONE AND TWO FAMILY	PLAN REVIEW	CHECKLIST
COMPONENT	SUBMITTED PLAN	FINDINGS/REVISIONS/DATES
STRUCTURAL		
FOOTING DIMENSIONS/DEPTH	8" x 16" FOOTING, 8" THICK WALL, 4" CONC. SLAB	
FOUNDATION DRAINAGE, FABRIC, DAMP PROOFING	ASPHALT TARP/PIPE/DRAIN FILTER FABRIC OVER THE DRAIN	
VENTILATION/ACCESS GRILL, SPACE ONLY	N/A	
ANCHOR BOLTS/STRAPS, SPACING	5/8" DIA. x 12" LONG HOOKED A307, 3'-0" O.C. & CORNERS	
LALLY COLUMN TYPE, GIRDER & HEADER SPANS	3 1/2" DIA. LALLY COLUMN ON 24" x 24" FOOTING 12" THICK MAX SPAN 5'-0"	
BUILT-UP WOOD CENTER GIRDER DIMENSIONS/TYPE	(3) 2x12 W/LEGER	
SILL/BAND JOIST TYPE & DIMENSIONS	2x6 PRESSURE TREATED, 2x10 RM	
FIRST FLOOR JOIST SPECIES DIMENSIONS AND SPACING	2x10 @ 16" O.C.	
SECOND FLOOR JOIST SPECIES DIMENSIONS AND SPACING	N/A	
ATTIC OR ADDITIONAL FLOOR JOISTS DIMENSIONS AND SPACING	ROOF TRUSSES @ 24" O.C. W/2x4 BOTTOM AND TOP CHORD	
PITCH, SPAN, SPACING & DIMENSION, ROOF RAFTER, FRAMING & CONNECTIONS	6/12 ROOF TRUSSES @ 24" O.C. SPANNING 28'-0" AND 18'-0"	
SHEATHING, FLOOR, WALL AND ROOF	3/4" TROWNING FLOOR SHEATHING 7/16" APA RATED WALL SHEATHING 5/8" APA RATED ROOF SHEATHING PER CODE	
FASTENER SCHEDULE		
PRIVATE GARAGE		
LIVING SPACE? FIRE SEPARATION	EXISTING BARN CONNECTION TO NEW MUDROOM/HOUSE	
OPENING PROTECTION	NO LIVING SPACE (1) HR. FIRE SEPARATION 5/8" TYPE 'X' G.M.B.	
EMERGENCY ESCAPE AND RESCUE OPENINGS	3068 FIRE RATED DOOR 4060 EGRESS WINDOWS	
ROOF COVERING	40 YEAR ASPHALT SHINGLES	
SAFETY GLAZING	N/A - SLIDER STANDARD	
ATTIC ACCESS	2x4x6 ATTIC ACCESS IN CLOSET	
CHIMNEY CLEARANCES/FIRE BLOCKING	N/A	
HEADER SCHEDULE	REFER TO HEADER SCHEDULE SHEET A1	
ENERGY EFFICIENT R-FACTORS OF WALLS, FLOORS, CEILINGS, BUILDING ENVELOPE, U-FACTOR TEMPERATURA	WALLS: R-21 CEILINGS: R-49 FLOOR: R-21 WINDOWS: U-FACTOR .35	
TYPE OF HEATING SYSTEM	REFER TO GENERAL NOTES	
MEANS OF EGRESS		
BASEMENT	YES - DOORHOUSE ACCESS	
NUMBER OF STAIRWAYS	4	
INTERIOR	2	
EXTERIOR	2	
TREADS AND RISERS	7" RISE 10" TREAD, 7 1/2" RISE	
WIDTH	3'-3" CLEAR	
HEADROOM	7'-0" CLEAR +/-	
GUARDRAILS & HANDRAILS	34" WITH RETURNS	
SMOKE DETECTORS LOCATION AND TYPE/INTERCONNECTED	REFER TO GENERAL NOTES A1	
DWELLING UNIT SEPARATION	N/A	
DECK CONSTRUCTION	13x10" 2x10 @ 18" O.C. (3) 2x12 BEAMS @ 4'-0" REFER TO DECK/JOIST CONNECTION DETAIL A3	