

City of Portland, Maine - Building or Use Permit Application

389 Congress Street, 04101 Tel: (207) 874-8703, Fax: (207) 874-8716

Permit No: 08-0819	Issue Date: 7/9/08	CBL: 372 A020001
-----------------------	-----------------------	---------------------

Location of Construction: 23 SMITH FARM LN	Owner Name: PIACENTINI CHRISTOPHER G	Owner Address: 23 SMITH FARM LN	Phone: 878-6600
Business Name:	Contractor Name: Builders Insulation	Contractor Address: 515 Riverside Industrial Parkw Portlan	Phone: 2078786600
Lessee/Buyer's Name	Phone:	Permit Type: HVAC	Zone:

Past Use: Residential Condo	Proposed Use: Residential Condo - Install Kingsman Gas Fireplace <i>unit # 16</i>	Permit Fee: \$40.00	Cost of Work: \$1,100.00	CEO District: 5
Proposed Project Description: Install Kingsman Gas Fireplace		FIRE DEPT: <input type="checkbox"/> Approved <input type="checkbox"/> Denied	INSPECTION: Use Group: <i>R-3</i> Type: <i>SB</i> <i>IMC 2003</i> <i>NFA 211</i> Signature: <i>CL M 7/9/08</i>	
		PEDESTRIAN ACTIVITIES DISTRICT (P.A.D.) Action: <input type="checkbox"/> Approved <input type="checkbox"/> Approved w/Conditions <input type="checkbox"/> Denied Signature: _____ Date: _____		

Permit Taken By: Imd	Date Applied For: 07/03/2008	Zoning Approval	
-------------------------	---------------------------------	------------------------	--

<p>1. This permit application does not preclude the Applicant(s) from meeting applicable State and Federal Rules.</p> <p>2. Building permits do not include plumbing, septic or electrical work.</p> <p>3. Building permits are void if work is not started within six (6) months of the date of issuance. False information may invalidate a building permit and stop all work..</p>	<p>Special Zone or Reviews</p> <input type="checkbox"/> Shoreland <input type="checkbox"/> Wetland <input type="checkbox"/> Flood Zone <input type="checkbox"/> Subdivision <i>O.K.</i> <input type="checkbox"/> Site Plan Maj <input type="checkbox"/> Minor <input type="checkbox"/> MM <input type="checkbox"/> Date: <i>7/9 a</i>	<p>Zoning Appeal</p> <input type="checkbox"/> Variance <input type="checkbox"/> Miscellaneous <input type="checkbox"/> Conditional Use <input type="checkbox"/> Interpretation <input type="checkbox"/> Approved <input type="checkbox"/> Denied Date: _____	<p>Historic Preservation</p> <input checked="" type="checkbox"/> Not in District or Landmark <input type="checkbox"/> Does Not Require Review <input type="checkbox"/> Requires Review <input type="checkbox"/> Approved <input type="checkbox"/> Approved w/Conditions <input type="checkbox"/> Denied Date: <i>a 7/9</i>
---	--	---	---

CERTIFICATION

I hereby certify that I am the owner of record of the named property, or that the proposed work is authorized by the owner of record and that I have been authorized by the owner to make this application as his authorized agent and I agree to conform to all applicable laws of this jurisdiction. In addition, if a permit for work described in the application is issued, I certify that the code official's authorized representative shall have the authority to enter all areas covered by such permit at any reasonable hour to enforce the provision of the code(s) applicable to such permit.

SIGNATURE OF APPLICANT	ADDRESS	DATE	PHONE
RESPONSIBLE PERSON IN CHARGE OF WORK, TITLE		DATE	PHONE



FILL IN AND SIGN WITH INK

APPLICATION FOR PERMIT HEATING OR POWER EQUIPMENT

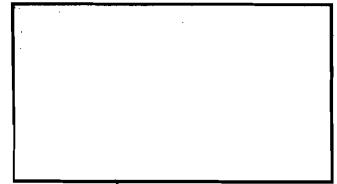

372 A02000

To the INSPECTOR OF BUILDINGS, PORTLAND, ME.

The undersigned hereby applies for a permit to install the following heating, cooking or power equipment in accordance with the Laws of Maine, the Building Code of the City of Portland, and the following specifications:

Location / CBL 1815 Washington Ave #16 Use of Building Living Date 7/3/08
 Name and address of owner of appliance Davis Const.
So. Portland
 Installer's name and address Builders Installed Prod. XX Cell
515 Riverside Ind. Pkwy. Telephone 878-6600

Location of appliance: Just
 Basement Floor
 Attic Roof

Type of Fuel:
 Gas Oil Solid

Appliance Name: Kingsman Fireplace
 U.L. Approved Yes No

Will appliance be installed in accordance with the manufacture's installation instructions? Yes No

IF NO Explain: _____

Type of Chimney:
 Masonry Lined
 Factory built _____
 Metal
 Factory Built U.L. Listing # _____
 Direct Vent
 Type Kingsman UL# _____
flex pipe

Type of Fuel Tank
 Oil JUL - 3 2008
 Gas

Size of Tank N/A Nat. Gas

Number of Tanks _____

Distance from Tank to Center of Flame _____ feet.

Cost of Work: \$ 1100.00
 Permit Fee: \$ 40.00

The Type of License of Installer:
 Master Plumber # _____
 Solid Fuel # _____
 Oil # _____
 Gas # PNT 3025
 Other _____

Approved

Approved with Conditions

Fire: _____
 Ele.: _____
 Bldg.: _____

See attached letter or requirement

[Signature]
 Inspector's Signature

7/3/08
 Date Approved

Signature of Installer Bill Ren

City of Portland, Maine - Building or Use Permit

389 Congress Street, 04101 Tel: (207) 874-8703, Fax: (207) 874-8716

Permit No: 08-0819	Date Applied For: 07/03/2008	CBL: 372 A020001
------------------------------	--	----------------------------

Location of Construction: 23 SMITH FARM LN 16	Owner Name: PIACENTINI CHRISTOPHER G	Owner Address: 23 SMITH FARM LN	Phone: () 878-6600
Business Name:	Contractor Name: Builders Insulation	Contractor Address: 515 Riverside Industrial Parkw Portlan	Phone: (207) 878-6600
Lessee/Buyer's Name	Phone:	Permit Type: HVAC	

Proposed Use: Residential Condo - Install Kingsman Gas Fireplace	Proposed Project Description: Install Kingsman Gas Fireplace
--	--

Dept: Zoning	Status: Approved	Reviewer: Chris Hanson	Approval Date: 07/09/2008
Note:	Ok to Issue: <input checked="" type="checkbox"/>		
Dept: Building	Status: Approved with Conditions	Reviewer: Chris Hanson	Approval Date: 07/09/2008
Note:	Ok to Issue: <input checked="" type="checkbox"/>		
1) The heating appliance/stove shall be installed, maintained and operated in accordance with the terms of the listing. 2) Prior to installing the solid fuel appliance, the product information which includes the UL listing shall be submitted. The heating unit shall be installed per the Listing, NFPA 211, IMC 2003 and the manufacturers instructions. 3) The installation must comply with the State of Maine Gas Regulations.			

Fan Kit Installation

Automatic On/Off Thermostat Controlled Fan Kit (Part # Z33FK)

Note: Fan to be located on right hand side of fireplace as per drawing

1. Open the lower front access cover.
2. The sensor (thermo-disc) needs to be secured under the firebox. Screws are factory installed with washers, make sure washers are used as spacers between bottom of firebox and thermo-disc mount.
3. Insert the two (2) #8x1/2 screws provided with the fan into the holes in the side of the fireplace opposite the gas line entry. Mount the fan using the keyhole slots in the fan body.
4. Install a junction box (type to except three prong plug) on the inside wall of the access area opposite the fan. Large holes are provided to allow wiring to enter the access area on the left of the unit. Connect the power, sensor and variable speed wall switch as shown in the wiring diagram.
5. Close lower access cover.
6. Turn the wall switch on (clockwise). Turn the fireplace on. Once the sensor unit reaches operating temperature in approximately 10 to 15 minutes the fan will turn on. The fan can be switched off, if desired, by turning the wall switch fully counter-clockwise.
7. To set the minimum fan speed, if desired, remove the variable speed switch from the wall mount. Turn the variable speed wall controller to its minimum setting (fully clockwise). Use the set screw on the side of the variable speed controller to increase or decrease the minimum fan speed. (It may be desirable to lower minimum fan speed to decrease the sound level created by the fan.) Reinstall switch into wall mount and cover with face plate.

OLD STYLE

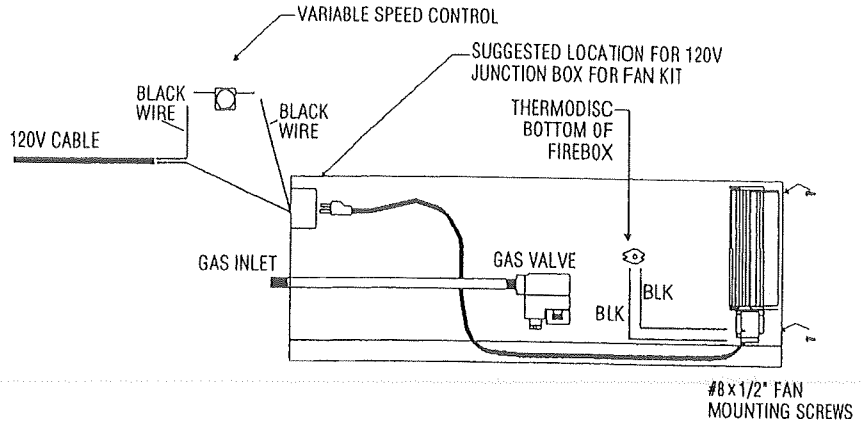

NEW STYLE

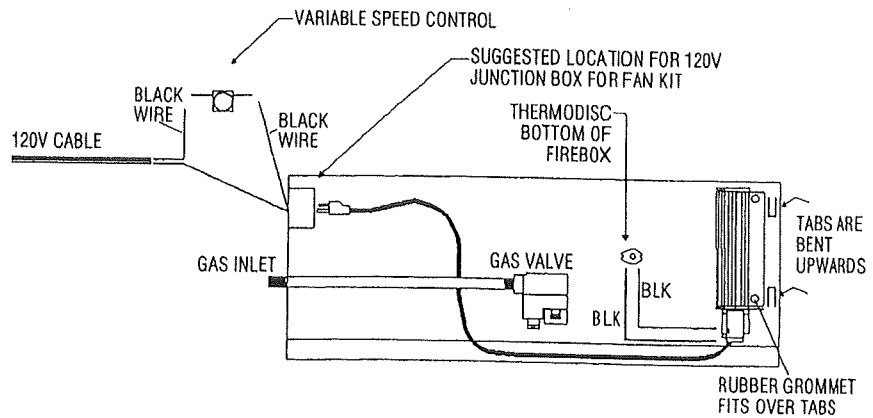

Electrical Services

All optional fan kits are equipped with a 120V, 60Hz blower.

Note: All electric connections are to be made in accordance with CSA Standard C22.1 - Canadian Electrical Code part I or with the National Electrical Code, ANSI/NFPA 70 (latest addition) and/or in accordance with local codes.

Caution: Should this fan require servicing, the power supply must be disconnected.

Vent Termination

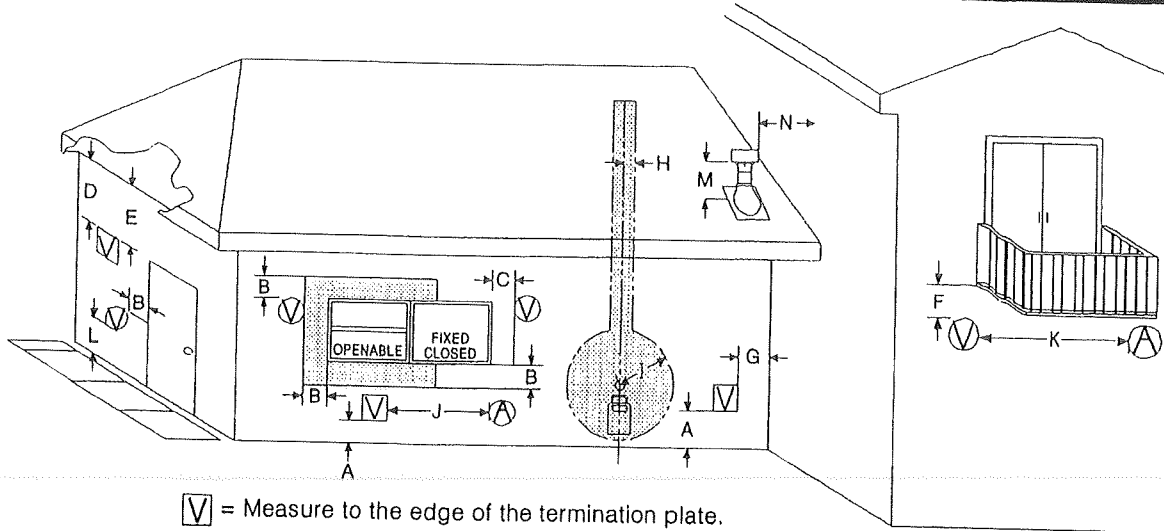

| = Measure to the edge of the termination plate.
| = Measure to the edge of the round termination.

| Vent Terminal

○ Air Supply

■ Area Where Terminal Not Permitted.

- A - Clearance above grade, veranda, porch, deck, or balcony 12 inches (30cm) minimum.^{1,2}
- B - Clearance to window or door that may be opened. 12 inches (30cm) minimum for appliances 100 000 Btuh (30 kW) and lower, in Canada. 9 inches, (23cm) for appliances 50 000 Btuh and lower, in USA.
- C - Clearance to permanently closed window minimum 12 inches (30cm) recommended to prevent condensation on window, in Canada. 9 inches, (23cm) for appliances 50 000 Btuh and lower, in USA.
- D - Vertical clearance to ventilated soffit located above the termination within a horizontal distance of 2 feet (60cm) from the center line of the termination. 18 inches (46cm) minimum.⁵
- E - Clearance to unventilated soffit 12 inches (30cm) minimum.
- F - Clearance under veranda, porch, deck or balcony 12 inches, (30cm) minimum.⁴ US,
- G - Clearance from a perpendicular inside wall or outer corner to the edge of the vent terminal plate is 3" (minimum).
- H - Clearance to each side of center line extended above meter/regulator assembly 3 feet (91cm) within a height 15 feet (4.5m) above the meter/regulator assembly.
- I - Clearance to service regulator vent outlet 3 feet (91cm) minimum.¹ US,
- J - Clearance to non-mechanical air supply inlet to building or the combustion air inlet to any other appliance: In Canada, 6 inches (15cm) for appliances ≤10,000 Btuh (3kW), 12 inches, (30cm) minimum for appliances >10,000 Btuh (3kW) and ≤100,000 Btuh (30kW), 36 inches (91cm) for appliances >100,000 Btuh (30kW). In the USA, 6 inches, (15cm) for appliances ≤10,000 Btuh (3kW), 9 inches (23cm) for appliances >10,000 Btuh (3kW) and ≤50,000 Btuh (15kW), 12 inches (30cm) for appliances >50,000 Btuh (15kW).
- K - Clearance to a mechanical air supply inlet 6 feet (1.8m) minimum.¹, in Canada. In USA, 3 feet (91cm) above if within 10 feet, (3m) horizontally.
- L - Clearance above paved sidewalk or a paved driveway located on public property 7 feet (2.1m) minimum.³
- M - Clearance above highest point of exit on roof 18 inches (45cm).
- N - Clearance to perpendicular wall 24 inches (60 cm).
(Recommended to prevent re-circulation of exhaust products. For additional requirements check local codes.)

NOTE: Clearances are to the edge of terminal plate, add 6-3/4" to clearances to arrive at center line.

NOTE: Local Codes or Regulations may require different clearances.

Termination

It is imperative that the vent termination be located observing the minimum clearances as shown. There must not be any obstruction such as bushes, garden sheds, fences, decks or utility buildings within 24" from the front of the termination plate.

Do not locate termination where excessive snow or ice build-up may occur. Be sure to check vent termination area after snow falls and clear to prevent accidental blockage of venting system. When using snow blowers, make sure snow is not directed towards vent termination area.

General Venting Information

The gas fireplace is approved to be vented either through the side wall or vertically through the roof.

This appliance is approved with Kingsman flex vent system and also approved for use with Simpson Duravent Direct Vent System (model DV-GS series), and AmeriVent Direct Vent Pipe System.

Kingsman flex vent system can be used with Simpson Duravent Direct Vent termination's (model DV-GS series).

When using Simpson Duravent or AmeriVent Direct Vent pipe a Kingsman/Duravent adapter must be used.

ONLY VENTING COMPONENTS SPECIFICALLY APPROVED AND LABELED FOR THIS FIREPLACE MAY BE USED.

Venting terminal shall not be recessed into a wall or siding.

Minimum clearance to combustibles on venting Vertical 1" with Kingsman Vent System 1 1/4" with Simpson Duravent Systems Top of Horizontal Pipe 1 1/2" Top of 90 degree bend in Minimum Enclosures of 50 1/2"-56 1/2" is 2 1/2" with insulation Sleeve Top of 90 degree bend in enclosure over 56 1/2" -60" is 4 1/2" without insulation sleeve. Top of 90 degree bend in enclosures over 60" is 2 1/2" without insulation sleeve. See page 7 and 8.

- 1 - In accordance with the current *CSA B149.1, Natural Gas and Propane Code.*
- 2 - In accordance with the current *ANSI Z223.1/NFPA 54, National Fuel Gas Code.*
- 3 - A vent shall not terminate directly above a sidewalk or paved driveway that is located between two single family dwellings and serves both dwellings.
- 4 - Permitted only if veranda, porch, deck, or balcony is fully open on a minimum of two sides beneath the floor.
- 5 - Clearance in accordance with local installation codes and the requirements of the gas supplier.

General Vent Installation Information

This gas appliance is approved to be vented either through the side wall or vertically through the roof. Only Kingsman venting kits and components specifically approved and LABELED for this stove may be used. This appliance is also approved for use with Simpson-Duravent Direct Vent system, Model DV-GS Series, and Ameri-Vent Direct Vent Pipe System.

SIMPSON DURAVENT OR AMERIVENT

When using Simpson Duravent or AmeriVent pipe a Duravent adapter must be used (part # ZDVDFFA for fireplaces). Follow installation instructions provided by Simpson Duravent for installation of pipe and adhere to the clearance to combustibles provided in this manual. Apply a bead of Mill Pac high temp sealant to all joints of pipes, adapters and termination as recommended.

Flex Pipe Venting

Flex pipe is shipped in unexpanded length. When installing pipe expand the lengths. Pipe can be expanded to twice their lengths e.g. 4ft. to 8ft. Fully expand pipe and cut off excess.

Do not use more than 2 couplers to extend short pipes. Single sections are preferred in an installation attaching at the fireplace and termination.

Place the spring spacers provided approximately every two feet to stabilize 4" flex in the center of 7" flex. When forming bends place spring in bend or before and after. (See Fig. 1).

Horizontal runs require support metal straps every 2 feet. In off set installation support straps should be used to stabilize pipe.

Expand 4" and 7" flex pipe to the point that the 7" protrudes approximately 2 to 3 inches past outer wall and the 4" flex protrudes approximately 2 to 3 inches past the 7" flex. See Fig. 1. Attach the 4" pipe to the termination first and secure with sealant and screws then attach the 7" flex to the termination with caulking and screws. Termination may then be moved back to the outer wall and attached to home screwing into the framing. Silicone around termination to waterproof. If siding shield is going to be used attach this using same attaching hole as the top of termination after termination has been caulked for waterproofing.

Use Hi Temp Sealant

Apply a bead of mill pac high temp sealant to all joints and use four screws to secure each pipe at fireplace, termination and any joint if joining any sections of pipe.

FRAMING DIMENSION

Combustible Wall

Cut a 11" hole through exterior wall and frame as shown below.

Non combustible Wall

Cut or drill 8" or 204mm diameter hole.

FIGURE 1

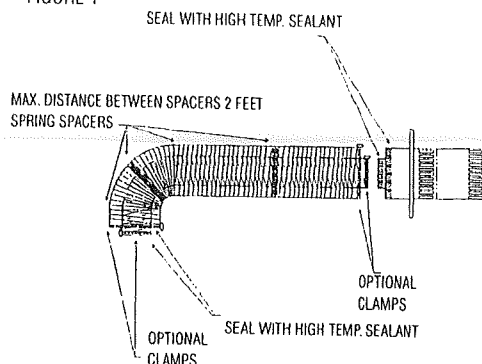

NOTE: It is critical to the proper and safe operation of this fireplace that on all connections the inner liner and the outer casing are both caulked with liberal amounts of sealant. Do not use any kind of tape or silicone other than that recommended in this manual. Mill Pac Sealant

Installation Of Side Wall Venting

1. The minimum distance from the bottom of fireplace to centre of vent is 32 inch (81 cm) (See Figure 1). Cut a hole through the wall allowing for a 11" x 11" (inside diameter) in combustible walls for wall thimble or an 8" diameter hole in a non-combustible wall (See Figure 2).
2. Note clearance to combustible above 90 degree bend in low profile enclosures 43" (inches) to 60" (inches) is 6" (inches) to the bend, in enclosures 60" (inches) and greater 2 1/2" (inches) to bend
3. Select the approximate vent length, precise measurements are not needed as your flex pipe can be expanded to twice its shipped length for ease of installation.
4. To install wall thimble centre over 11" x 11" (inch) framing from both sides of wall and secure. Route flex vent pipe through wall thimble (See Figure 1).
5. Before joining pipes, apply a bead of high temperature sealant (Mill Pac) to end of pipe. First attach the four inch (4") flue pipe to the vent termination with sealant, and secure with 4 screws provided. At this time make sure the spacer springs are attached to the (4") flex pipe as required. Then attach the seven inch (7") pipe by the same method.
6. Mount vent termination and seal to wall using caulking around the wall thimble to weather proof. After installing the vent termination, double check to make sure the pipe extends properly through wall thimble and into vent termination.
7. Before joining pipes to fireplace flue, apply a bead of high temperature sealant (Mill Pac) to end of pipe. First attach the four inch (4") flue pipe to fireplace with Mill Pac sealant to the flue pipe and secure with 4 screws provided. At this time verify that the spacer springs are attached properly to the (4") flex pipe as required. Then attach the seven inch (7") pipe by the same method.
8. Support horizontal pipes every two (2) feet (61 cm) with metal strap bands. Re-check fireplace to make sure it is levelled and properly positioned and secured.
9. Support vertical pipes to maintain a minimum of 1" or greater clearance to combustibles with metal strapping bands.

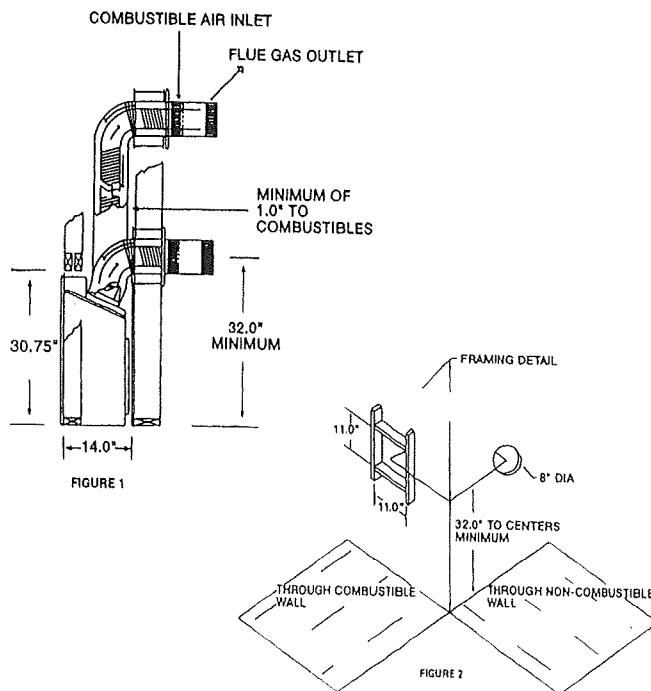

Note when using SIMPSON DURAVENT ADAPTER (ZDVDFFA) the fireplace clearances from the back standoff is one inch, thus increasing the framing depth to 15".

Venting Routes And Components

Since it is very important that the vent system maintain its balance between the combustion air intake and the flue gas exhaust, certain limitations as to vent configurations apply and must be strictly adhered to.

The table showing the relationship between vertical and horizontal side wall venting will help to determine the various vent lengths.

The maximum horizontal run with the 90 degree bend at the fireplace flue outlet is 4 ft/122cm (Figure #1). The maximum horizontal run is 20 ft (6.1 m) when the vertical run is 7 ft/2.1m (Figure #2). Note: 1/4" vertical rise is required for every 12" of horizontal run.

The maximum number of 45 degree bends per side wall installation is two (2) in the horizontal run and then you must reduce the length of the horizontal by 18 inches for each 45 degree bend.

The maximum vertical run is 40 ft/12.2 meters.

Special Note: For each 45 degree bend installed in the horizontal run, the length of the horizontal run must be reduced by 18" (45cm). This does not apply if the 45 degree bends are installed on the vertical part of the vent system.

Example: If according to the table, the length of the horizontal run is 10 feet, and two 45 degree bends are required, the horizontal run length must be reduced to 7 feet.

2 additional 90° bends or equals are allowed. The horizontal run must be reduced by 36" per each 90° bend, or 18" per each 45° bend.

Important: Always locate the fireplace in such a way that a minimum of offsets and/or horizontal runs are required. 1/4" vertical rise is required for every 12" horizontal run.

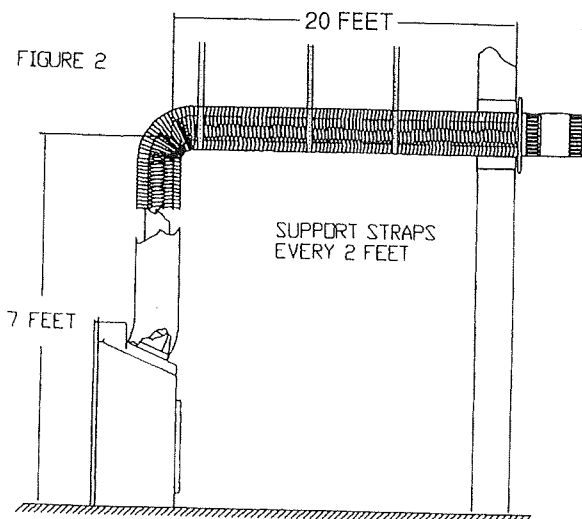
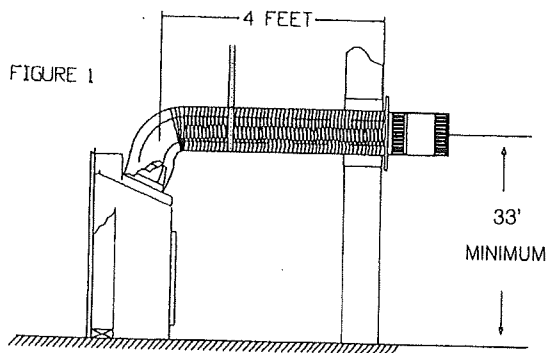

How To Use The Vent Table

1. Determine the height of the system and the number of bends required.
2. Having determined the vertical distance determine the maximum horizontal section allowed.
3. Vent table has been established for 90° horizontal/vertical runs. With use of flex pipe distance not having 90° bends will not fall into vent table standards. See Fig. B.

Venting Table From Bottom of Fireplace

for venting to a maximum of 40 ft. (12.2 meters)

Total Vertical		Max Total Horizontal	
Feet	Meters	Feet	Meters
4	1.2	5	1.5
5	1.5	8	2.4
6	1.8	12	3.7
7	2.1	20	6.1
8	2.4	20	6.1
9	2.7	20	6.1
10	3.0	20	6.1
11	3.4	20	6.1
12	3.7	20	6.1
13	4.0	20	6.1
14	4.3	20	6.1
15	4.6	20	6.1
16	4.9	20	6.1
17	5.2	20	6.1
18	5.5	20	6.1
19	5.8	20	6.1
20	6.1	20	6.1
25	7.5	15	4.6
30	9	10	3.0
40	12.2	0	0

Example A:

If the vertical dimension from the floor of the fireplace is 6ft, the horizontal run to the wall flange of the vent termination must not exceed 12ft.

NOTE: The final location of the fireplace must be such that the horizontal vent dimensions fall within those stated on the graph. The Maximum Vertical vent run is 40ft. (12.2 meters).

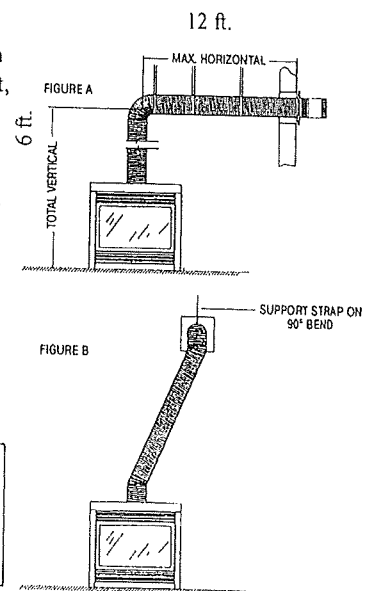

Important: Minimum clearance between vent pipes and combustible materials is 1 inch (25mm).

It is recommended for Propane Horizontal Installations that the venting should be a minimum of one foot vertical off the flue before the elbow on any horizontal runs of one foot or greater. This allows for cleaner combustion and greatly reduces carboning and cleaning of glass. (Does not apply to Back Flue Models).