

**ROOF PLAN**  
1/8" = 1'-0"

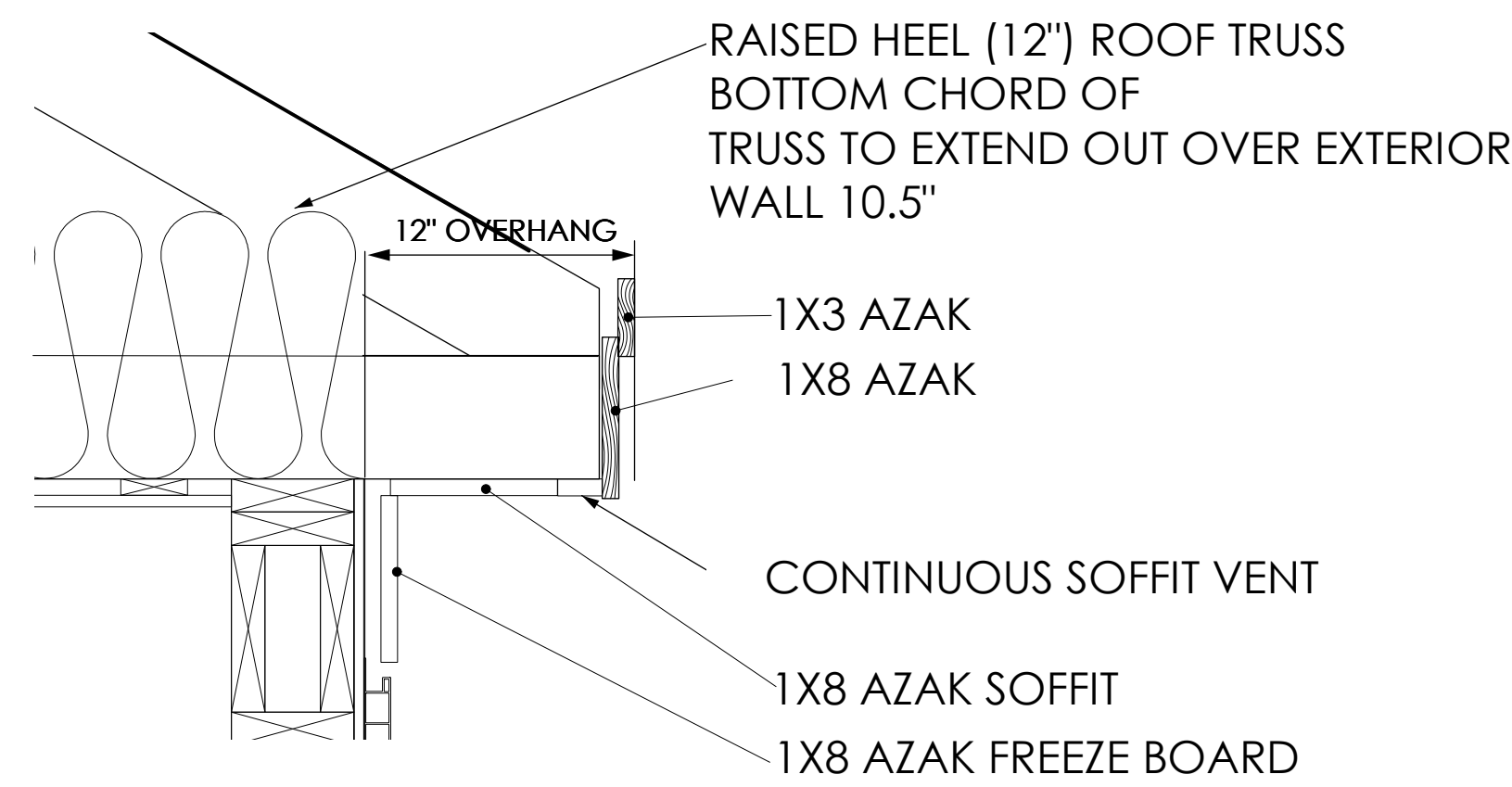

**ROOF OVERHANG DETAIL**

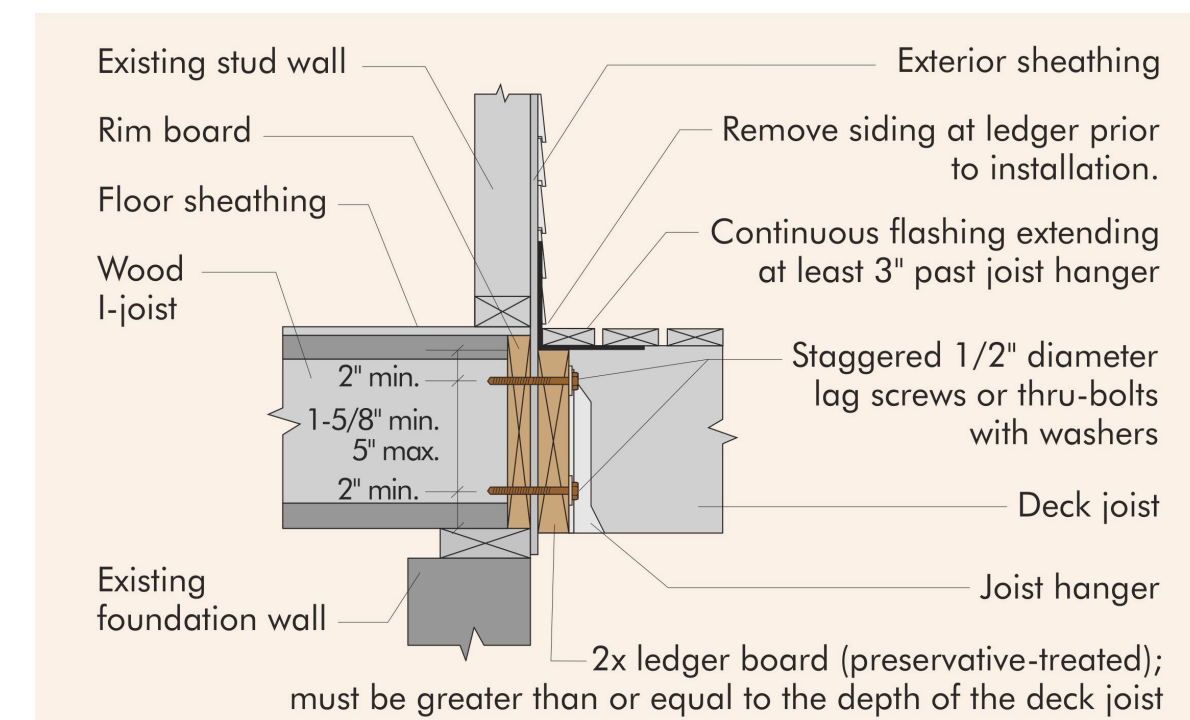

**DECK ATTACHMENT**

ATTACHMENT OF 2X LUMBER LEDGERS TO RIM BOARD - USE 1/2-INCH DIAMETER LAG SCREWS WITH A MINIMUM NOMINAL LENGTH OF 4 INCHES OR 1/2-INCH DIAMETER THROUGH-BOLTS WITH WASHERS AND NUTS. IN BOTH CASES, USE A DESIGN VALUE OF 350 LBF PER FASTENER (SEE DETAIL 8C). FASTENERS SHOULD BE STAGGERED IN 2 ROWS WITH A MINIMUM OF 2 INCHES FROM ANY EDGE TO THE CENTER OF HOLES. FOR FASTENER SPACING, CONSULT YOUR LOCAL DISTRIBUTOR. CAUTION: THE LAG SCREW SHOULD BE INSERTED IN A LEAD HOLE BY TURNING WITH A WRENCH, NOT BY DRIVING WITH A HAMMER. OVER-TORQUING CAN SIGNIFICANTLY REDUCE THE LATERAL RESISTANCE OF THE LAG SCREW AND SHOULD THEREFORE BE AVOIDED. SEE THE NDS 2005 FOR THE APPROPRIATE

**RADON CONTROL**

4 IN. DIAMETER GAS-TIGHT PVC VERTICAL VENT PIPE, CLEARLY LABELED "RADON PIPE" OR "RADON SYSTEM," CONNECTED TO AN OPEN T-FITTING IN THE AGGREGATE LAYER (OR CONNECTED TO GEOTEXTILE DRAINAGE MATTING ACCORDING TO THE MANUFACTURER'S INSTRUCTIONS) BENEATH THE POLYETHYLENE SHEETING, EXTENDING UP THROUGH THE CONDITIONED SPACES (IN CHASE WALL BEHIND STAIRWELL) AND TERMINATING A MINIMUM OF 12 IN. ABOVE THE ROOF OPENING. FOR CRAWLSPACES, INSTALL AT LEAST 5 FT. OF HORIZONTAL PERFORATED DRAIN TILE ON EITHER SIDE OF THE T-FITTING, ATTACHED TO THE VERTICAL RADON VENT PIPE BENEATH THE SHEETING AND RUNNING PARALLEL TO THE LONG DIMENSION OF THE HOUSE; AND

RADON FAN INSTALLED IN THE ATTIC (I.E., AN ACTIVE SYSTEM) OR AN ELECTRICAL RECEPTACLE INSTALLED IN AN ACCESSIBLE ATTIC LOCATION NEAR THE RADON VENT PIPE (I.E., A PASSIVE SYSTEM) TO FACILITATE FUTURE FAN INSTALLATION IF NEEDED; AND

FOUNDATION AIR SEALING WITH POLYURETHANE CAULK OR THE EQUIVALENT AT ALL SLAB OPENINGS, PENETRATIONS, AND CONTROL OR EXPANSION JOINTS. SUMP COVERS ALSO SHALL BE AIR SEALED (E.G., MECHANICALLY ATTACHED WITH FULL GASKET SEAL OR EQUIVALENT.)

**EXTERIOR WALLS:**

- CERTAIN TEED VINYL SIDING
- TYPAR BUILDING WRAP OR EQUIVALENT
- 1/2" ADVANTECH SHEATHING
- 2" X 6" KD SPF @ 24" OC
- 5.5" DENSE PACK BLOWN-IN CELLULOSE INSULATION (R 21)

- 2" X 6" ACQ TREATED SILL PLATE
- SILL SEALER

FINISHED GRADE

MIN DEPTH FOR FROST PROTECTION

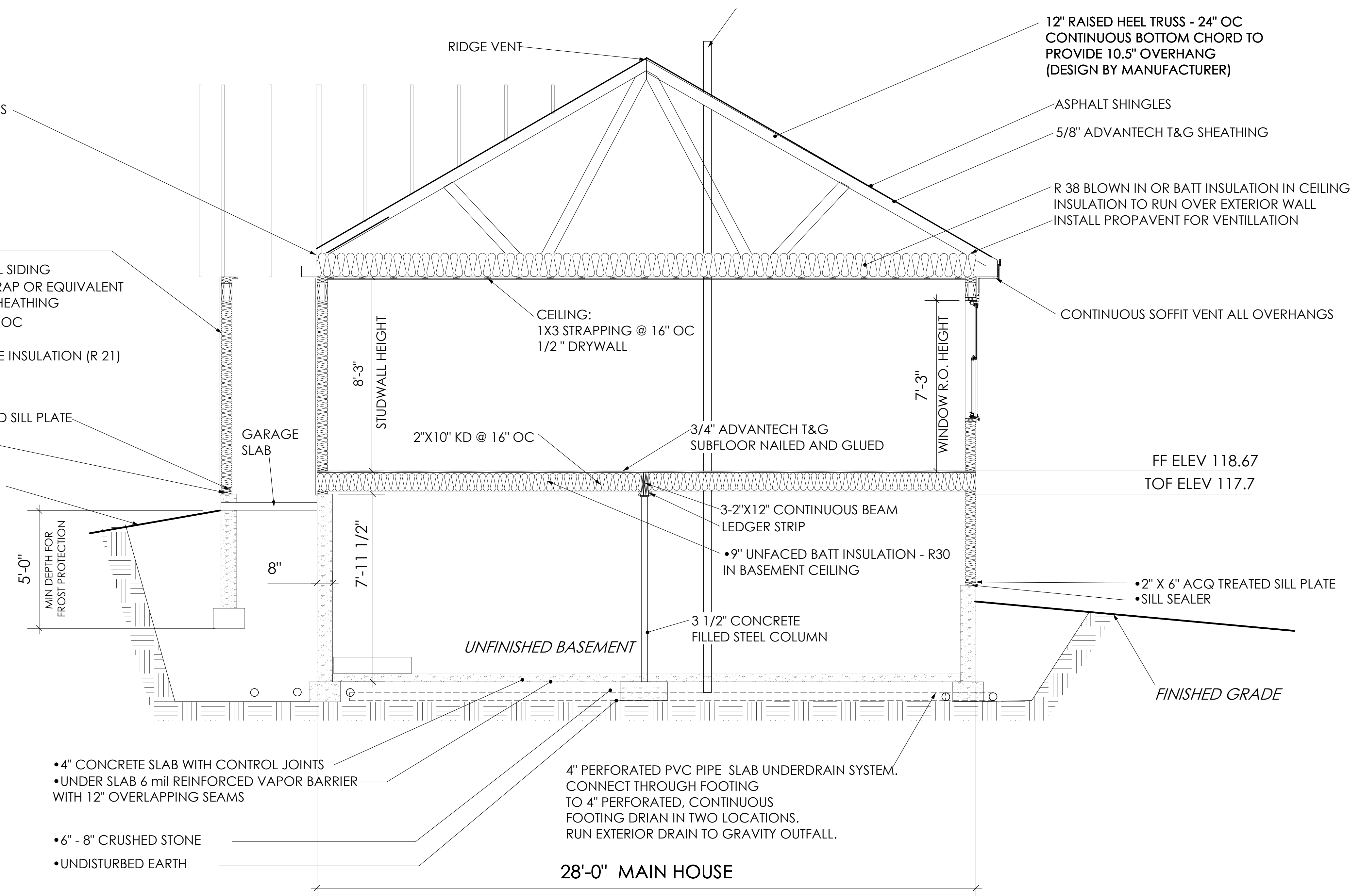

**SECTION 1**

3/8" = 1'-0"

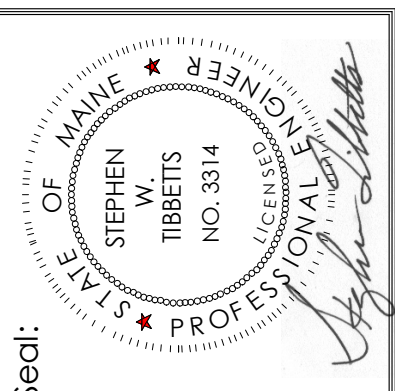

Seal: **Stephen W. Tibbetts, Inc.**  
Appraisals, Brokerage, & Consulting  
1326 Washington Ave  
Portland, ME 04103

Engineer: **Stephen W. Tibbetts, P.E.**  
Professional Civil Engineer  
15 Oak Ridge Road, Brunswick, Maine 04011  
(207) 725-2667

Project: **NEW RESIDENCE**  
8 BALLPARK DRIVE  
PORTLAND, MAINE

Date	Revisions
AUGUST 22, 2016	AS NOTED

**CROSS SECTION DETAILS**

**A4**