

TYPICAL FOUNDATION WALL SCALE: 1"=1'-0"

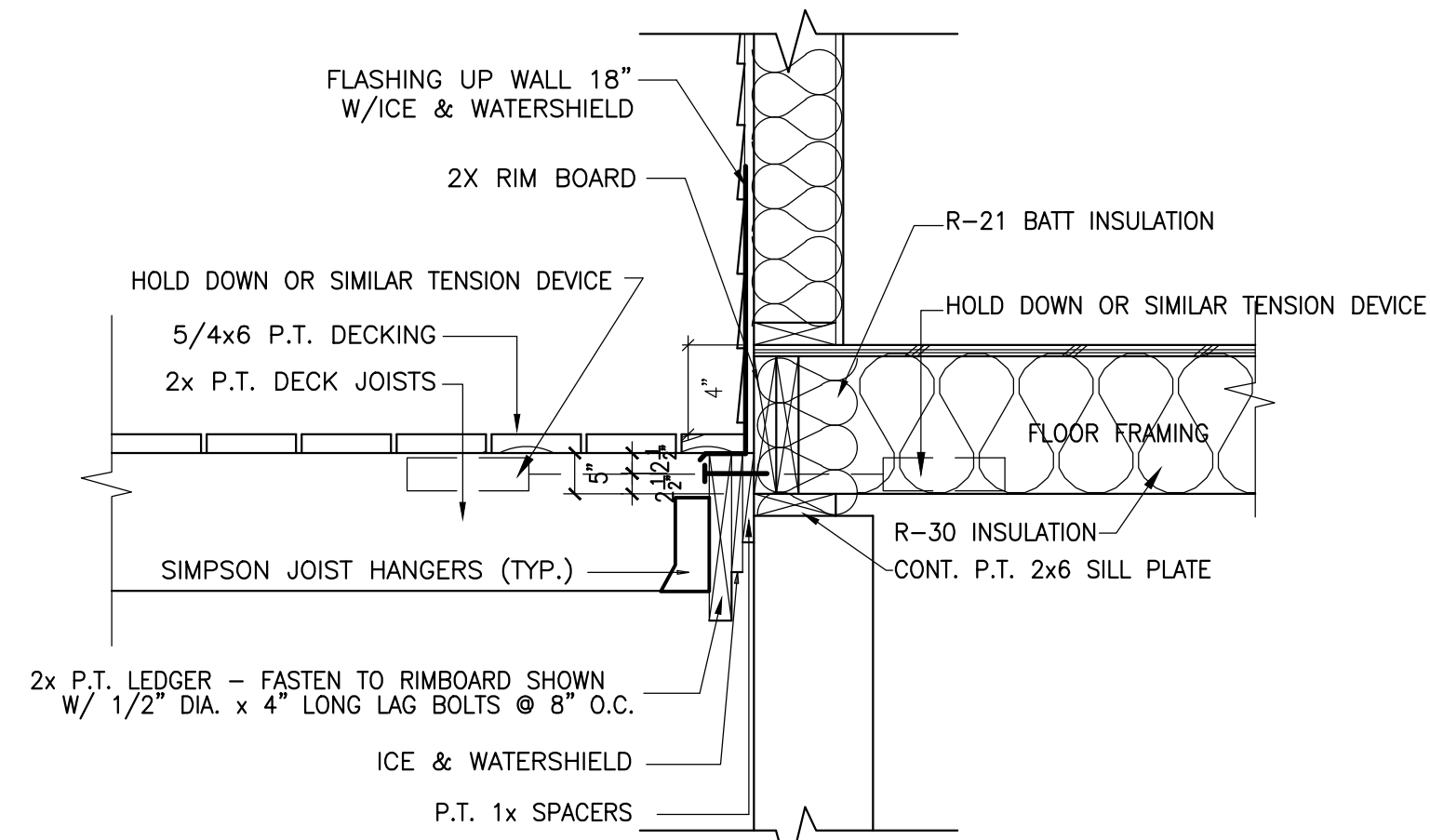

1 DECK /JOIST CONNECTION DETAIL SCALE: 1"=1'-0"

HEADER SCHEDULE	
ROUGH OPENING	HEADER SIZE
0 - 3'-0"	(3) - 2x6
3'-1" - 4'-6"	(3) - 2x8
4'-7" - 5'-8"	(3) - 2x10
5'-9" - 7'-0"	(3) - 2x12

NOTE: PROVIDE JAMBS BOTH ENDS AS FOLLOWS:
 2x6 JACK PLUS 2x6 KING UP TO 4'-6" ROUGH OPENING
 (2) 2x6 JACKS PLUS (2) 2x6 KINGS UP TO 7'-0" ROUGH OPENING

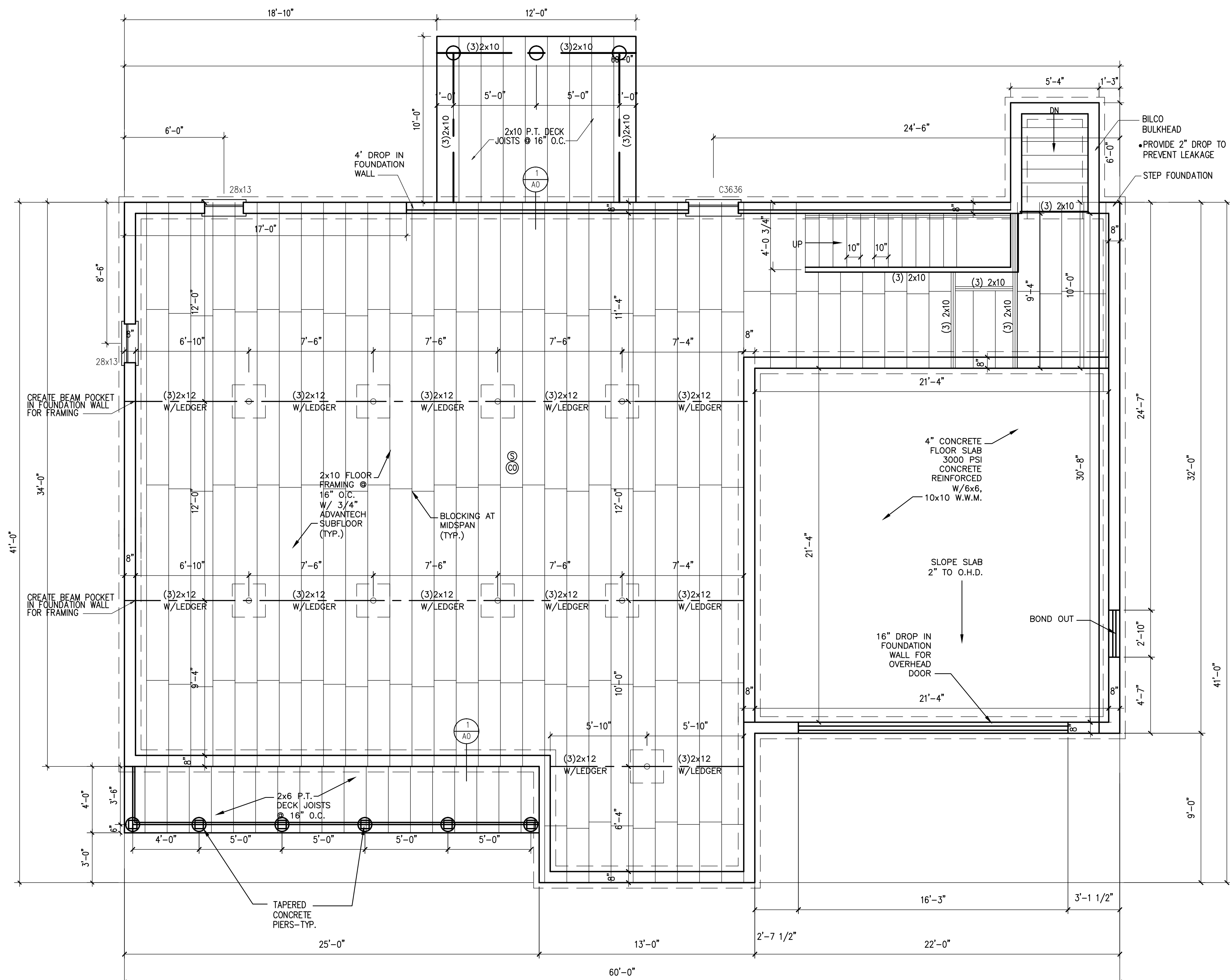

FOUNDATION/FRAMING PLAN 1/4"=1'-0"

- GENERAL NOTES:
- All work shall be in accordance with IRC 2009, IBC Basic Building Code 2009, NFPA-70 National Electric Code, Maine State Plumbing Code, ASHRAE, U.L., NFPA Codes and all local, State and Federal requirements.
 - All applicable Federal, State and Municipal regulations shall be followed, including the Federal Department of Labor Occupational Safety and Health act.
 - All required City and State permits must be obtained before any construction begins.
 - It is the contractor's sole responsibility to determine erection procedures and sequence to ensure the safety of the building and its components during erection. This includes the addition of necessary shoring, sheeting, temporary bracing, guys or tie-downs. Such material shall remain the property of the contractor after completion of the project.
 - Structural, Mechanical, Electrical and Plumbing design and installation by others shall be performed in accordance with local, State and Federal standards.
 - All fire ratings indicated shall be continuous to underside of fire rated ceiling or underside of roof deck. Seal all openings & mechanical penetrations with approved fire safing material.
 - Building shall have approved smoke detectors in accordance with NFPA-101 Life Safety Code. Smoke detectors shall initiate alarm that is audible in the sleeping rooms of each unit.
 - HVAC installation to be in accordance with ASHRAE, NFPA-90A, OR NFPA-90B and all federal, local and State codes. Ventilation or heat equipment shall be in accordance with NFPA-91, NFPA-211, NFPA-31, NFPA-54 and NFPA-70 as applicable.

ONE AND TWO FAMILY COMPONENT	PLAN REVIEW SUBMITTED PLAN	CHECKLIST FINDINGS/REVISIONS/DATES
STRUCTURAL		
FOOTING DIMENSIONS/DEPTH	8"x16" FOOTING, 8" THICK WALL, 4" CONC. SLAB	
FOUNDATION DRAINAGE, FABRIC, DAMP PROOFING	ASPHALT TAR/PIPE/DRAIN FILTER FABRIC OVER THE DRAIN	
VENTILATION/ACCESS CRAWL SPACE ONLY	N/A	
ANCHOR BOLTS/STRAPS, SPACING	5/8" DIA. x 12" LONG HOOKED A307, 3'-0" O.C. & CORNERS	
LALLY COLUMN TYPE, GIRDER & HEADER SPANS	3 1/2" DIA. LALLY COLUMN ON 24"x24" FOOTING 12" THICK MAX SPAN 5'-6"	
BUILT-UP WOOD CENTER GIRDER DIMENSIONS/TYPE	(3) 2x12 W/LEDGER	
SILL/BAND JOIST TYPE & DIMENSIONS	2x6 PRESSURE TREATED, 2x10 RM	
FIRST FLOOR JOIST SPECIES DIMENSIONS AND SPACING	2x10 @ 16" O.C.	
SECOND FLOOR JOIST SPECIES DIMENSIONS AND SPACING	N/A	
ATTIC OR ADDITIONAL FLOOR JOISTS DIMENSIONS AND SPACING	ROOF TRUSSES @ 24" O.C. W/2x4 BOTTOM AND TOP CHORD	
PITCH, SPAN, SPACING & DIMENSION, ROOF RAFTER: FRAMING & CONNECTIONS	7/12 ROOF TRUSSES @ 24" O.C. SPANNING 38'-0" 7/12 ROOF TRUSSES @ 24" O.C. SPANNING 32'-0" W/HURRICANE CLIP TIES DOWNS	
SHEATHING: FLOOR, WALL AND ROOF	3/4" ADVANTACH FLOOR SHEATHING, 7/16" APA RATED WALL SHEATHING, 5/8" APA RATED ROOF SHEATHING	
FASTENER SCHEDULE	PER CODE	
PRIVATE GARAGE		
LIVING SPACE? FIRE SEPARATION	NO LIVING SPACE, (1) HR. FIRE SEPARATION 5/8" TYPE 'X' G.W.B.	
OPENING PROTECTION	21088 FIRE RATED DOOR	
EMERGENCY ESCAPE AND RESCUE OPENINGS	4060 EGRESS WINDOWS	
ROOF COVERING	40 YEAR ASPHALT SHINGLES	
SAFETY GLAZING	N/A	
ATTIC ACCESS	24x36 SCUTTLE-REFER TO FLOOR PLAN	
CHIMNEY CLEARANCES/FIRE BLOCKING	N/A	
HEADER SCHEDULE	REFER TO HEADER SCHEDULE SHEET A1	
ENERGY EFFICIENT R-FACTORS OF WALLS, FLOORS, CEILINGS, BUILDING ENVELOPE, U-FACTOR FENESTRATION	WALLS: R-21 CEILING: R-49 FLOOR: R-21 WINDOWS: U-FACTOR .35	
TYPE OF HEATING SYSTEM	REFER TO GENERAL NOTES	
MEANS OF EGRESS		
BASEMENT	YES - BULKHEAD	
NUMBER OF STAIRWAYS	4	
INTERIOR	2-INCLUDING BULKHEAD STAIRS	
EXTERIOR	2	
TREADS AND RISERS	7 1/4" RISE 10" TREAD	
WIDTH	3'-0" CLEAR	
HEADROOM	6'-11 5/8" CLEAR IN BASEMENT	
GUARDRAILS & HANDRAILS	34" WITH RETURNS	
SMOKE DETECTORS LOCATION AND TYPE/INTERCONNECTED	REFER TO GENERAL NOTES A1	
DWELLING UNIT SEPARATION	N/A	
DECK CONSTRUCTION	2x6 & 2x10 @ 16" O.C. W/(3) 2x BEAMS REFER TO DECK/JOIST CONNECTION DETAIL 1/A0	

LOT 5 BALLPARK
 PORTLAND, MAINE

DRAWINGS THIS SHEET
 FOUNDATION/FRAMING PLAN
 DETAILS
 CHECKLIST

A0

08/25/13