



System No. HW-D-1067
XHBN.HW-D-1067
Joint Systems

Page Bottom

Design/System/Construction/Assembly Usage Disclaimer

- Authorities Having Jurisdiction should be consulted in all cases as to the particular requirements covering the installation and use of UL Certified products, equipment, system, devices, and materials.
Authorities Having Jurisdiction should be consulted before construction.
Fire resistance assemblies and products are developed by the design submitter and have been investigated by UL for compliance with applicable requirements. The published information cannot address every construction nuance encountered in the field.
When field issues arise, it is recommended the first contact for assistance be the technical service staff provided by the product manufacturer noted for the design. Users of fire resistance assemblies are advised to consult the general Guide Information for each product category and each group of assemblies. The Guide Information includes specifics concerning alternate materials and alternate methods of construction.
Only products which bear UL's Mark are considered Certified.

Joint Systems

See General Information for Joint Systems

System No. HW-D-1067

June 07, 2010

Assembly Ratings - 1 and 2 Hr (See Item 2)

Nominal Joint Width - 2-1/2 In.

Class II Movement Capabilities - 40% Compression or Extension

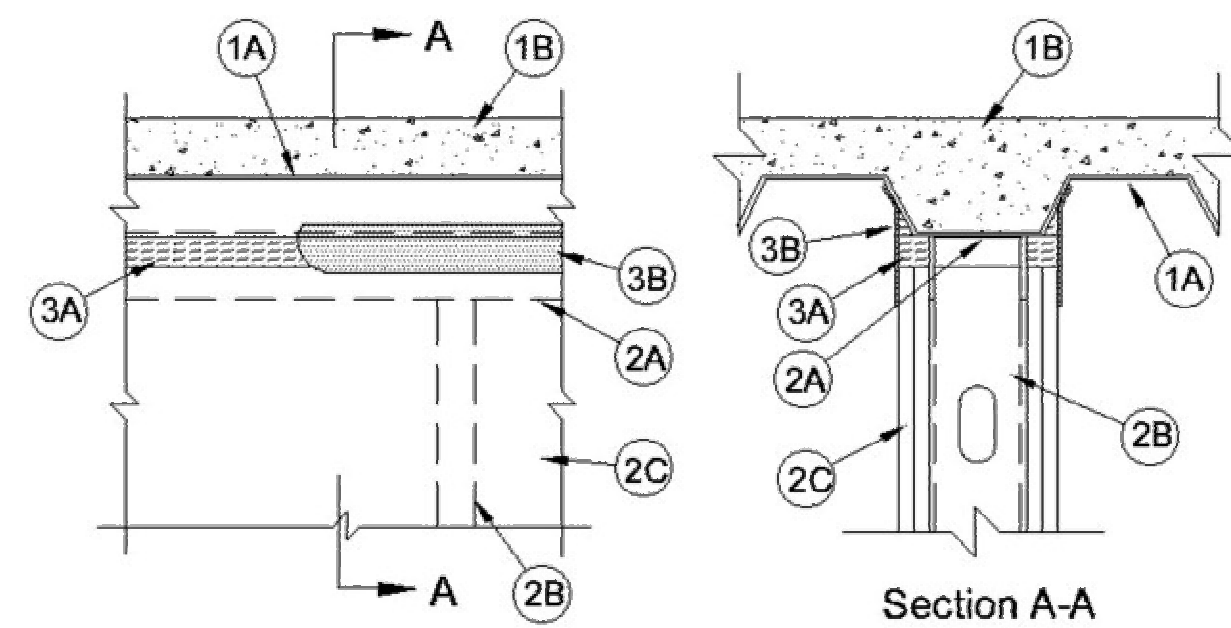

1. Floor Assembly - The fire-rated fluted steel deck/concrete floor assembly shall be constructed of the materials and in the manner described in the individual D900 Series Floor-Ceiling Design in the UL Fire Resistance Directory and shall include the following construction features:

A. Steel Floor and Form Units* - Max 3 in. (76 mm) deep galv steel fluted floor units.

B. Concrete - Min 2-1/2 in. (64 mm) thick reinforced concrete, as measured from the top plane of the floor units.

1A. Roof Assembly - (Not Shown) - As an alternate to the floor assembly, a fire rated fluted steel deck roof assembly may be used. The roof assembly shall be constructed of the materials and in the manner described in the individual P900 Series Roof-Ceiling Design in the UL Fire Resistance Directory. The hourly rating of the roof assembly shall be equal to or greater than the hourly rating of the wall assembly. The roof assembly shall include the following construction features:

A. Steel Roof Deck - Max 3 in. (76 mm) deep galv steel fluted roof deck.

B. Roof Insulation - Min 2-1/4 in. (57 mm) thick poured insulating concrete, as measured from the top plane of the steel roof deck.

2. Wall Assembly - The 1 hr or 2 hr fire rated gypsum board/steel stud wall assembly shall be constructed of the materials and in the manner described in the individual U400 or V400 Series Wall and Partition Design in the UL Fire Resistance Directory and shall include the following construction features:

A. Steel Floor and Ceiling Runners - Floor and ceiling runners of wall assembly shall consist of galv steel channels sized to accommodate steel studs (Item 2B). Flange height of ceiling runner shall be min 1/4 in. (6 mm) greater than max extended joint width. Ceiling runner centered beneath and parallel with the valley of the deck and secured to valley with steel fasteners, steel masonry anchors or welds spaced max 24 in. (610 mm) OC.

B. Studs - Steel studs to be min 3-1/2 in. (89 mm) wide. Studs cut 1-1/4 in. to 1-1/2 in. (32 to 38 mm) less in length than assembly height with bottom resting in and resting on floor runner and with top nesting in ceiling runner without attachment. Stud spacing not to exceed 24 in. (610 mm) OC.

C. Gypsum Board* - Gypsum board installed to a min total thickness of 5/8 in. (16 mm) or 1-1/4 in. (32 mm) on each side of wall for 1 hr and 2 hr rated assemblies, respectively. Wall to be constructed as specified in the individual Wall and Partition Design in the UL Fire Resistance Directory, except that a max 2-1/2 (64 mm) gap shall be maintained between the top of the gypsum board and the bottom of the steel deck and the top row of screws shall be installed into the studs 5 in. (127 mm) below the lower surface of the floor or roof.

The hourly rating of the joint system is dependent on the hourly rating of the wall.

3. Joint System - Max separation between bottom of floor or roof and top of gypsum board at time of installation of joint system is 2-1/2 in. (64 mm). The joint system is designed to accommodate a max 40 percent compression or extension from its installed width. The joint system consists of forming material and a fill material, as follows:

A. Forming Material* - Nom 5/8 in. or 1-1/4 in. (16 or 32 mm) wide strips of min 4 pcf (64 kg/m³) mineral wool batt insulation, for 1 and 2 hr rated assemblies, respectively. Strips compressed 50 percent in thickness and inserted cut-edge first into gap between top of gypsum board and bottom of the floor or roof deck, flush with both surfaces of the wall. Adjoining lengths of batt to be tightly butted with butted seams spaced min 48 in. (1.2 m) apart along the length of the joint.

ROCK WOOL MANUFACTURING CO - Delta Board

ROXUL INC - SAFE

THERMAFIBER INC - Type SAF

A1. Forming Material* - Strips - As an alternate to Item 3A, nom 5/8 in. (16 mm) and 1-1/4 in. (32 mm) wide pre-cut mineral wool strips for 1 and 2 hr rated assemblies, respectively. The strips are compressed 50 percent in thickness and inserted cut-edge first into the gap between the top of the gypsum board and the bottom of the floor or roof deck, flush with both surfaces of the wall. Adjoining lengths of strips to be tightly butted with butted seams spaced min 48 in. (1.2 m) apart along the length of the joint.

HILTI CONSTRUCTION CHEMICALS, DIV OF HILTI INC - CP 767 Speed Strips

B. Fill, Void or Cavity Material* - Min 1/16 in. (1.6 mm) dry thickness (min 1/8 in. or 3.2 mm wet thickness) of fill material sprayed on each side of the wall to completely cover mineral wool forming material and to overlap a min of 1/2 in. (13 mm) onto gypsum board and steel deck on both sides of wall.

HILTI CONSTRUCTION CHEMICALS, DIV OF HILTI INC - CP672 Firestop Spray or CFS-SP WB Firestop Joint Spray

*Bearing the UL Classification Mark

Last Updated on 2010-06-07

Questions? Print this page Terms of Use Page Top

© 2014 UL LLC

When the UL Leaf Mark is on the product, or when the word "Environment" is included in the UL Mark, please search the UL Environment database for additional information regarding this product's certification.

The appearance of a company's name or product in this database does not in itself assure that products so identified have been manufactured under UL's Follow-Up Service. Only those products bearing the UL Mark should be considered to be Certified and covered under UL's Follow-Up Service. Always look for the Mark on the product.

UL permits the reproduction of the material contained in the Online Certification Directory subject to the following conditions: 1. The Guide Information, Assemblies, Constructions, Designs, Systems, and/or Certifications (files) must be presented in their entirety and in a non-misleading manner, without any manipulation of the data (or drawings). 2. The statement "Reprinted from the Online Certifications Directory with permission from UL" must appear adjacent to the extracted material. In addition, the reprinted material must include a copyright notice in the following format: "© 2014 UL LLC".

NOTE: THESE DETAILS ARE INCLUDED FOR REFERENCE PURPOSES AND DO NOT INCLUDE ALL APPLICABLE UL SYSTEM TESTED DETAILING TO BE UTILIZED THROUGH OUT THE PROJECT. PROVIDE APPLICABLE UL SYSTEM TESTED DETAILING FOR ALL FIRE RATED AND SMOKE PARTITION PENETRATIONS, WHETHER INDICATED WITHIN THESE DRAWINGS OR NOT.



Design No. X901
BXUV.X901
Fire Resistance Ratings - ANSI/UL 263

Page Bottom

Design/System/Construction/Assembly Usage Disclaimer

- Authorities Having Jurisdiction should be consulted in all cases as to the particular requirements covering the installation and use of UL Listed or Classified products, equipment, system, devices, and materials.
Authorities Having Jurisdiction should be consulted before construction.
Fire resistance assemblies and products are developed by the design submitter and have been investigated by UL for compliance with applicable requirements. The published information cannot address every construction nuance encountered in the field.
When field issues arise, it is recommended the first contact for assistance be the technical service staff provided by the product manufacturer noted for the design. Users of fire resistance assemblies are advised to consult the general Guide Information for each product category and each group of assemblies. The Guide Information includes specifics concerning alternate materials and alternate methods of construction.
Only products which bear UL's Mark are considered as Classified, Listed, or Recognized.

Fire Resistance Ratings - ANSI/UL 263

See General Information for Fire Resistance Ratings - ANSI/UL 263

Design No. X901

August 03, 2011

Rating - 4 Hr

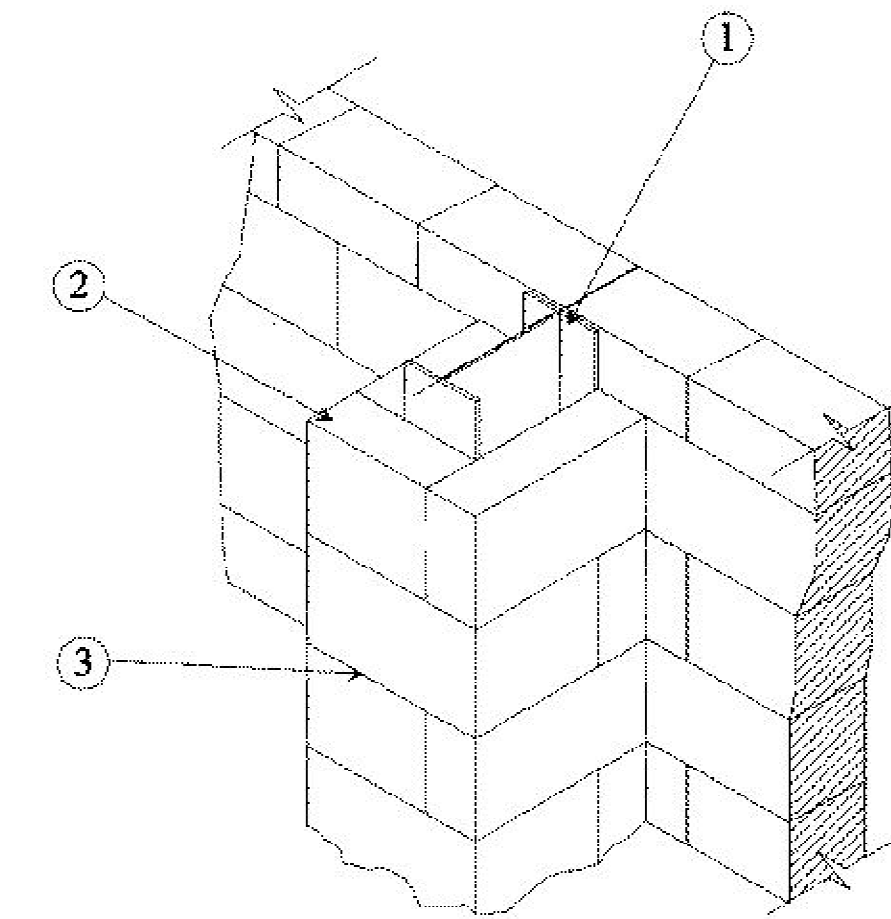

- 1. Steel Column - Any size W shaped steel column, steel tube or steel pipe.
2. Precast Autoclaved Aerated Concrete Blocks or Panels - Min 4 in. thick by min 7-7/8 in. high by min 23-5/8 in. long blocks or min 8 in. thick by 2 ft wide panels installed either horizontally or vertically. Panels mechanically attached to the concrete floor and ceiling.

AERCON FLORIDA L L C - AC-2, AC-3.3, AC-4, AC-4.4, AC-6, AC-6.6

XELLA MEXICANA S A DE C V - AAC-2, AAC-3.3, AAC-4, AAC-6

- 3. Thin Bed Mortar - Blocks laid in a ANSI A118.4 Latex/Portland cement thin bed mortar installed with vertical joints staggered.

*Bearing the UL Classification Mark

Last Updated on 2011-08-03

Questions? Print this page Terms of Use Page Top

© 2013 UL LLC

When the UL Leaf Mark is on the product, or when the word "Environment" is included in the UL Mark, please search the UL Environment database for additional information regarding this product's certification.

The appearance of a company's name or product in this database does not in itself assure that products so identified have been manufactured under UL's Follow-Up Service. Only those products bearing the UL Mark should be considered to be Listed and covered under UL's Follow-Up Service. Always look for the Mark on the product.

UL permits the reproduction of the material contained in the Online Certification Directory subject to the following conditions: 1. The Guide Information, Designs and/or Listings (files) must be presented in their entirety and in a non-misleading manner, without any manipulation of the data (or drawings). 2. The statement "Reprinted from the Online Certifications Directory with permission from UL" must appear adjacent to the extracted material. In addition, the reprinted material must include a copyright notice in the following format: "© 2013 UL LLC".

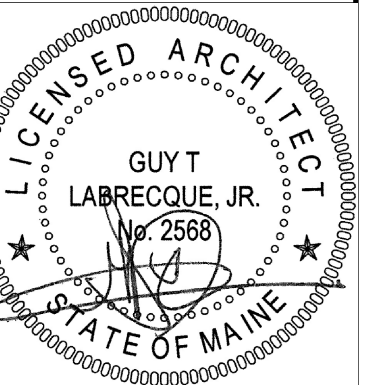

CWS ARCHITECTS ARCHITECTURE | INTERIOR DESIGN
264 US ROUTE ONE BOX 6, SUITE 100-2A SCARBOROUGH, MAINE 04074 T: 207-774-4441 WWW.CWSARCH.COM

DESIGNER

OWNER

FAIRPOINT COMMUNICATIONS

1 DAVIS FARM ROAD PORTLAND ME 04101

PROJECT

5 DAVIS FARM ROAD MERGER

5 DAVIS FARM ROAD PORTLAND ME 04103

DRAWING

UL DESIGN DETAILS

CWS PROJECT NUMBER: 17048

REVISIONS

Table with 5 columns for revision details.

DRAWING NUMBER

LS3.01

SCALE: AS NOTED

DATE: 1-2-2018

ISSUED FOR PERMITTING