

PROJECT NAME: REVERSIDE SOUTH GOLF COURSE

PROPOSED DEVELOPMENT ADDRESS:
1010 REVERSIDE ST PORTLAND, ME 04103

PROJECT DESCRIPTION:
THIS PROJECT ENTAILS A 797 SQ FT PROSHOP AND 536 SQ FT MEETING SPACE

CHART/BLOCK/LOT: 360 A-2 PRELIMINARY PLAN _____ (date)
351 A-2 FINAL PLAN _____ (date)

CONTACT INFORMATION:

Applicant – must be owner, Lessee or Buyer Name: <u>CITY OF PORTLAND</u> Business Name, if applicable: <u>FACILITIES</u> Address: <u>389 CONGRESS ST</u> City/State: <u>PTLD, ME</u> Zip Code: <u>04101</u>	Applicant Contact Information Work # <u>874-8893</u> Home# Cell # <u>233-8523</u> Fax# <u>874-8423</u> e-mail: <u>KRA@PORTLANDMAINE.GOV</u>
Owner – (if different from Applicant) Name: Address: City/State: Zip Code:	Owner Contact Information Work # Home# Cell # Fax# e-mail:
Agent/ Representative Name: <u>KATHY ALVES</u> Address: <u>65 HANDOVER ST</u> City/State: <u>PORTLAND, ME</u> Zip Code: <u>04101</u>	Agent/Representative Contact information Work # Cell # <u>SEE ABOVE</u> e-mail:
Billing Information Name: Address: City/State: Zip Code:	Billing Information Work # Cell # Fax# e-mail:

Engineer Name: <i>MIKE FARMER</i> Address: <i>W/ ASSISTANCE FROM WOODDARD CURRAN</i> City/State : Zip Code:	Engineer Contact Information Work # Cell # Fax# e-mail:
Surveyor Name: <i>WILLIAM SCOTT</i> Address: City/State : Zip Code:	Surveyor Contact Information Work # Cell # Fax# e-mail:
Architect Name: Address: City/State : Zip Code:	Architect Contact Information Work # Cell # Fax# e-mail:
Attorney Name: Address: City/State : Zip Code:	Attorney Contact Information Work # Cell # Fax# e-mail:

APPLICATION FEES:

Check all reviews that apply. (Payment may be made by Cash or Check payable to the City of Portland.)

NOTE: AS A CITY PROJECT WE ASK THAT FEES BE WAIVED

Level II Development (check applicable reviews)	Fees Paid (office use)	Other Reviews (check applicable reviews)	Fees Paid (office use)
<input type="checkbox"/> Less than 10,000 sq. ft. (\$400.00) <input type="checkbox"/> After-the-fact Review (\$1,000.00 plus applicable application fee)	<input type="checkbox"/> <input type="checkbox"/>	<input type="checkbox"/> Traffic Movement (\$1,000) <input type="checkbox"/> Stormwater Quality (\$250) <input type="checkbox"/> Section 14-403 Review (\$400 + \$25/lot) # of Lots <input type="checkbox"/> x \$25/lot = _____ <input type="checkbox"/> Other _____ <input type="checkbox"/> Change of Use <input type="checkbox"/> Flood Plain <input type="checkbox"/> Shoreland <input type="checkbox"/> Design Review <input type="checkbox"/> Housing Replacement <input type="checkbox"/> Historic Preservation	<input type="checkbox"/> <input type="checkbox"/> <input type="checkbox"/>
The City invoices separately for the following: <ul style="list-style-type: none"> • Notices (\$.75 each) • Legal Ad (% of total Ad) • Planning Review (\$40.00 hour) • Legal Review (\$75.00 hour) Third party review is assessed separately.			
Plan Amendments (check applicable reviews) <input type="checkbox"/> Planning Staff Review (\$250) <input type="checkbox"/> Planning Board Review (\$500)	Fees Paid (office use) <input type="checkbox"/> <input type="checkbox"/>		

APPLICATION SUBMISSION

As of December 1, 2010, all site plans and written application materials must be uploaded to a website for review. At the time of application, instructions for uploading the plans will be provided to the applicant. One paper set of the plans, written materials and application fee must be submitted to the Planning Division Office to start the review process.

Until December 1, 2010, submissions shall include seven (7) packets with folded plans containing the following materials:

1. Seven (7) full size site plans that must be folded.
2. Seven (7) copies of all written materials or as follows, unless otherwise noted:
 - a. Application form that is completed and signed.
 - b. Cover letter stating the nature of the project.
 - c. All Written Submittals (Sec. 14-525 2. (c), including evidence of right, title and interest.
3. A stamped standard boundary survey prepared by a registered land surveyor at a scale not less than one inch to 100 feet.
4. Plans and maps based upon the boundary survey and containing the information found in the attached sample plan checklist.
5. Copy of the checklist completed for the proposal listing the material contained in the submitted application.
6. One (1) set of plans reduced to 11 x 17.

Refer to the application checklist for a detailed list of submittal requirements.

Portland's development review process and requirements are outlined in the Land Use Code (Chapter 14), which includes the Subdivision Ordinance (Section 14-491) and the Site Plan Ordinance (Section 14-521). Portland's Land Use Code is on the City's web site: www.portlandmaine.gov Copies of the ordinances may be purchased through the Planning Division.

I hereby certify that I am the Owner of record of the named property, or that the owner of record authorizes the proposed work and that I have been authorized by the owner to make this application as his/her authorized agent. I agree to conform to all applicable laws of this jurisdiction. In addition, if a permit for work described in this application is issued, I certify that the Planning Authority and Code Enforcement's authorized representative shall have the authority to enter all areas covered by this permit at any reasonable hour to enforce the provisions of the codes applicable to this permit.

This application is for a Level II Site Plan review. It is not a permit to begin construction. An approved site plan, a Performance Guarantee, Inspection Fee, Building Permit, and associated fees will be required prior to construction. Other Federal, State or local permits may be required prior to construction, which are the responsibility of the applicant to obtain.

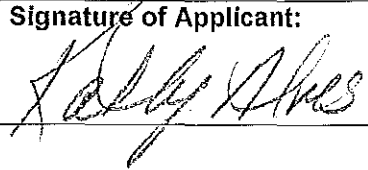
Signature of Applicant: 	Date: 3/29/13
--	------------------

PROJECT DATA

The following information is required where applicable, in order complete the application

Total Site Area	9,932,000 sq. ft.
Proposed Total Disturbed Area of the Site	2,800 sq. ft.
(If the proposed disturbance is greater than one acre, then the applicant shall apply for a Maine Construction General Permit (MCGP) with DEP and a Stormwater Management Permit, Chapter 500, with the City of Portland)	
IMPERVIOUS SURFACE AREA	
• Proposed Total Paved Area	33,978 sq. ft.
• Existing Total Impervious Area	5032 sq. ft.
• Proposed Total Impervious Area	4467 sq. ft.
• Proposed Total Impervious Area	_____ sq. ft.
• Proposed Impervious Net Change	DECREASE 565 sq. ft.
<i>*SEE ATTACHED SHEET FROM WOODWARD & CURRAN</i>	
BUILDING AREA	
• Proposed Building Footprint	1702 sq. ft.
• Proposed Building Footprint Net change	1026 sq. ft.
• Existing Total Building Floor Area	676 sq. ft.
• Proposed Total Building Floor Area	1334 sq. ft.
• Proposed Building Floor Area Net Change	658 sq. ft.
• New Building	(yes or no)
ZONING	
• Existing	RECREATION / OPEN SPACE
• Proposed, if applicable	
LAND USE	
• Existing	GOLF COURSE
• Proposed	GOLF COURSE
RESIDENTIAL, IF APPLICABLE	
• Proposed Number of Affordable Housing Units	
• Proposed Number of Residential Units to be Demolished	
• Existing Number of Residential Units	
• Proposed Number of Residential Units	
• Subdivision, Proposed Number of Lots	
PARKING SPACES	
• Existing Number of Parking Spaces	68
• Proposed Number of Parking Spaces	70
• Number of Handicapped Parking Spaces	2
• Proposed Total Parking Spaces	72
BICYCLE PARKING SPACES	
• Existing Number of Bicycle Parking Spaces	0
• Existing Number of Bicycle Parking Spaces	0
• Proposed Number of Bicycle Parking Spaces	6
• Total Bicycle Parking Spaces	6
ESTIMATED COST OF PROJECT	125,000.00

SEE PLAN FIGURES #1, 2, 3



41 HUTCHINS DRIVE
PORTLAND, MAINE 04102
TEL. (207) 774-2112
FAX (207) 774-6635

CLIENT Riverside Pro shop Areas
PROJECT Net Impervious Areas
DESIGNED BY Denise Cameron DATE 3/14/13
CHECKED BY _____ DATE _____
PROJECT NO. _____ SHEET NO. 1 OF 1

EXISTING IMPERVIOUS AREAS

EXISTING BLDG & CONCRETE PAD	=	885	Sq FT
EXISTING BITUMINOUS AREAS	=	1101	Sq FT
EXISTING COMPACTED GRAVEL	=	3046	Sq FT
TOTAL EXISTING IMPERVIOUS		<u>5032</u>	<u>Sq FT</u>

PROPOSED IMPERVIOUS AREAS

BUILDING	=	1334	Sq FT
PORCH	=	368	Sq FT
CONCRETE PAD	=	120	Sq FT
GRAVEL & BITUMINOUS	=	2645	Sq FT
TOTAL PROPOSED IMPERVIOUS	=	<u>4467</u>	<u>Sq FT</u>

TOTAL IMPERVIOUS CALCULATIONS

EXISTING	=	5032	Sq FT
PROPOSED	=	4467	Sq FT
NET DECREASE	=	-565	Sq FT

Level 11 Preliminary Site Plan Amendments

4/1/13

To: Planning

From: City Of Portland (Facilities Dept)

Re: Project # 2012-432

Enclosed please find amendments that are being requested due to the relocation of the Pro Shop. The redesign was prepared by Scott Simonds Architects through Woodard Curran. Amendments being requested are as follows:

1. Construct building in location of existing structure.
2. Increase sq ft from 777 to 1702. (includes 8'X46' porch)

Using this design has significantly reduced the total amount of excavation that needs to occur. The amount of impervious area has been reduced slightly. The new parking lot layout has increased from 68 to 72 spaces, this includes 2 van accessible spaces as well.

Original Site Plan Review Conditions 1-8 will be addressed as follows:

1. New landscape plan will be provided by city arborist.
2. The condenser unit has been removed from the project.
3. Attached is a proposed WPLED-9 fixture that would replace the existing fixture located on the utility pole. Also attached are cut sheets for exterior fixtures to be mounted on the building. *Note- WRAP9 KIM fixture is the same fixture used on the Bayside Trail. All proposed lighting is a standard we use on most city properties.
4. Myself and Captain Pirone met and discussed this item. The sq ft increase falls below the NFPA code to require fire protection. There are 2 fire hydrants located within this area. One at 315' the other at 600'. See attached sheet from the Portland Water District.
5. Myself and Frank Brancley met on this matter as well. Due to failure of the septic system at some point records are not available. Water was used minimally and un metered. These issues are being addressed in the project.
6. The septic system was removed by the city in the fall of 2012.
7. No signage will be added as part of this project. Recreation will apply for permits once they have a design and plan.
8. The sidewalk I've been told will be done in the next 60 days by Public Services.

Project progress as of 4/1/13:

Demo Permit issued on 3/12/13- Existing building has been removed.

Trench opening permit issued on 3/25/13- Trench has been opened, conduits have been installed.

Unitil Application Approved on 3/29/13: City staff met on site with Unitil on 4/1/13 to discuss gas tap. This is all set and will happen on 4/3/13.

Portland Water District Approval 3/29/13- Application was submitted and approved for water tap location. Fees have been paid.

Foundation permit request has been submitted as of 4/1/13. Building permit request will be submitted on Monday 4/8/13.

Street opening application has been submitted for Unitils work on 4/3/13.

An onsite meeting was held with Phil DiPierro on 4/1/13. Phil had a few minor request that we resolved on this day.



PORTLAND MAINE

Strengthening a Remarkable City, Building a Community for Life - www.portlandmaine.gov

4/1/13

Please review proposed amendments to project # 2012-432 Riverside So Golf Course

Fire Dept Check List Review Sheet items 1-10:

1. **City of Portland 389 Congress St Portland, Me Facilities Dept 874-8895**
2. **Scott Simonds 75 York St Portland, Me 772-4656**
3. **Mercantile Space**
4. **1334 Sg Ft Single Story Structure**
5. **See Attached Plans**
6. **N/A as discussed between Chris Pirone and Kathy Alves on 4/1/13.**
7. **See attached drawing per Portland Water District.**
8. **6" Main into property for irrigation, 1" Domestic line with a 1" meter in building.**
9. **See Drawing 001. 2 Access points have been provided.**
10. **Code summary review was done on 4/1/13.**

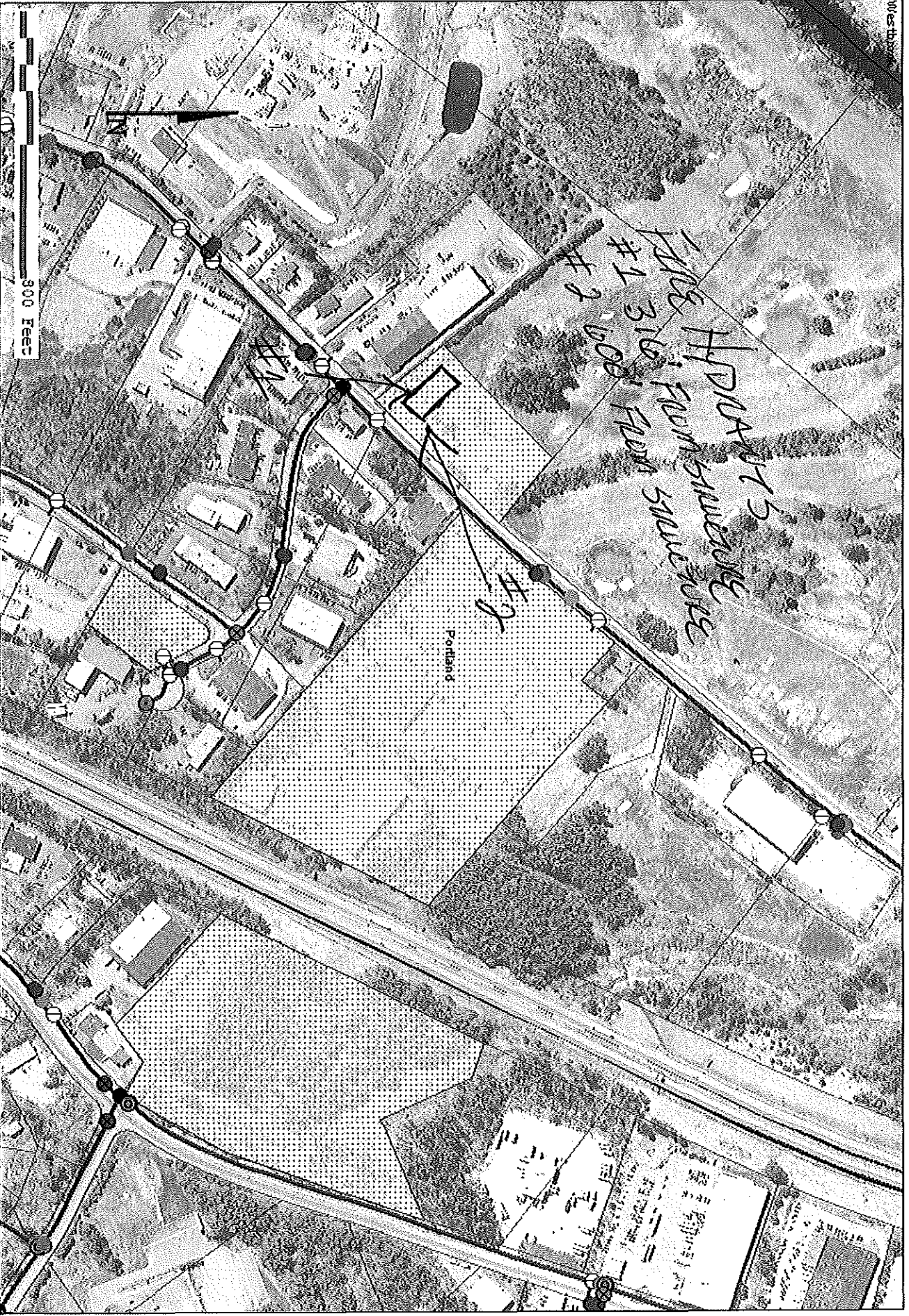

1158 Riverside Street

PORTLAND WATER
March 29, 2013

Amendment to Wastewater Capacity Application

4/1/13

Planning Project#: 2012-432

To: Planning/ Sewer Division

Re: 1010 Riverside St (Riverside Golf Course South)

Prior consumption was not available due to the fact that a septic system was in place originally. The septic system failed sometime ago, water usage was not being metered at the time, therefore consumption records are not available.

The new design calls for a forced main to be put in place. A new 1" meter will monitor water flow for domestic use. GPD calculations are based on 75 persons a day @ 12 gallons each per Mr. Brancley.

See attached sheets COO2/COO3 for design.

CUL SHEET #1



KIM LIGHTING

WP9LE-LED

WARP9™ - Large, Electronic LED

revision 4/22/09 • wp9le-led.pdf

Type:
Job:
Catalog number:

Approvals:

Mtg. Fixture Electrical Module Finish Options
See page 2 See pages 3-4

Date:
Page: 1 of 4

Select pole from Kim Pole Catalog. If pole is provided by others indicate O.D. for arm fitting.

Specifications

WP9LE-LED
Large Electronic
120 Light Emitting Diodes
Total Max System Watts = 175W

Maximum weight:
35 lb. electronic

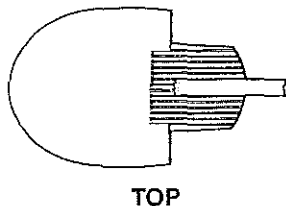

TOP

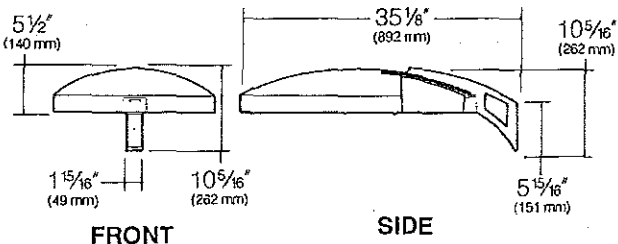

FRONT

SIDE

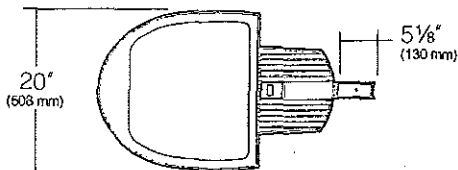

BOTTOM

Housing: One-piece die-cast, low copper (<0.6% Cu) aluminum alloy with integral cooling ribs over the electrical compartment. Solid barrier wall separates optical and electrical compartments. A single die-cast aluminum cam-latch provides positive locking and sealing of the optical chamber. A one-piece extruded and vulcanized silicone gasket seals the housing against the lens surface.

Electronic Driver Module: One-piece die-cast, low copper (<0.6% Cu) aluminum alloy with integral cooling ribs over exposed bottom surface. Integral hinges and slide latch with stainless steel hardware provides no-tool mounting and removal from housing. All electronic components are UL and CSA recognized and mounted directly to the driver tray for maximum heat dissipation.

Lens: Clear 3/16" thick tempered glass lens retained by a stainless steel piano hinge and a single die-cast aluminum cam-latch. The edges are camouflaged to conceal the outer portion of the housing.

Optical Module: Precision injection molded, high specular reflectors are positioned to achieve directional control toward desired task. Secondary high specular reflector 95% Miro4 panels surround the module to redirect light downward. No fasteners are placed on the reflective surface. The entire assembly fastens to the housing as a one-piece module.

Support Arm: Heavy cast, low copper aluminum alloy with stainless steel mounting bolts. A pole reinforcing plate is provided with wire strain relief. Arm is circular cut for specified round pole.

Finish: Super TGIC thermoset polyester powder coat paint, 2.5 mil nominal thickness, applied over a titanated zirconium conversion coating; 2500 hour salt spray test endurance rating. Standard colors are Black, Dark Bronze, Stealth Gray™, Platinum Silver, or White. Custom colors are available

CAUTION: Fixtures must be grounded in accordance with national, state and/or local electrical codes, Failure to do so may result in serious personal injury.

Listings and Ratings

UL cUL 1598 ¹	CE	IP66 Rated	25C Ambient
--------------------------	----	------------	-------------

¹Suitable for wet locations.
KIM LIGHTING RESERVES THE RIGHT TO CHANGE SPECIFICATIONS WITHOUT NOTICE.



U.S. Patent D568,521

Large WARP9 LED Photometry

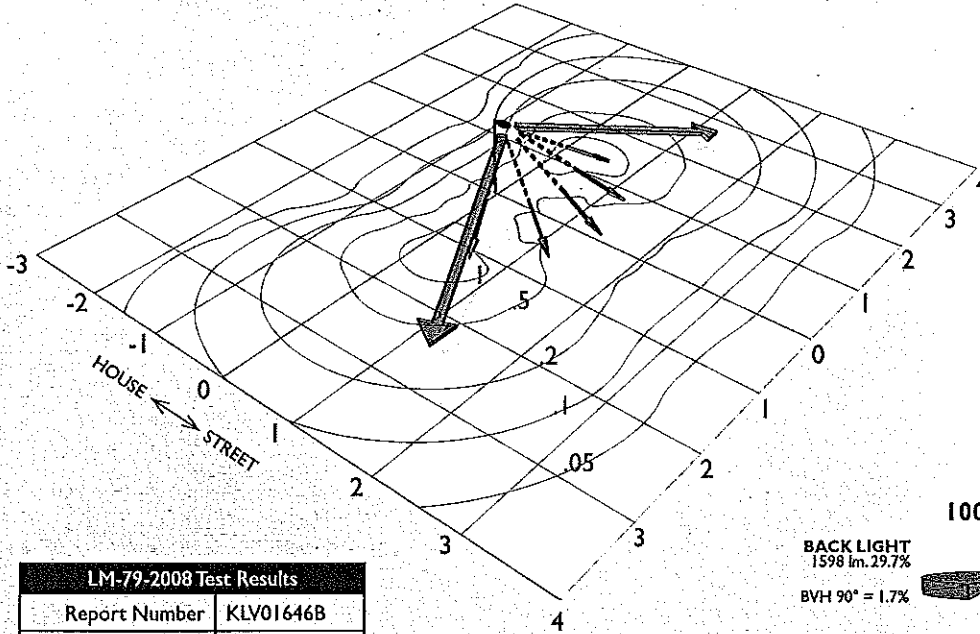

LM-79-2008 Test Results	
Report Number	KLV01646B
Mounting Height	20 Feet
Light Dist. Type	Type II
Total Flux	5377 Lm.
System Watts	175W

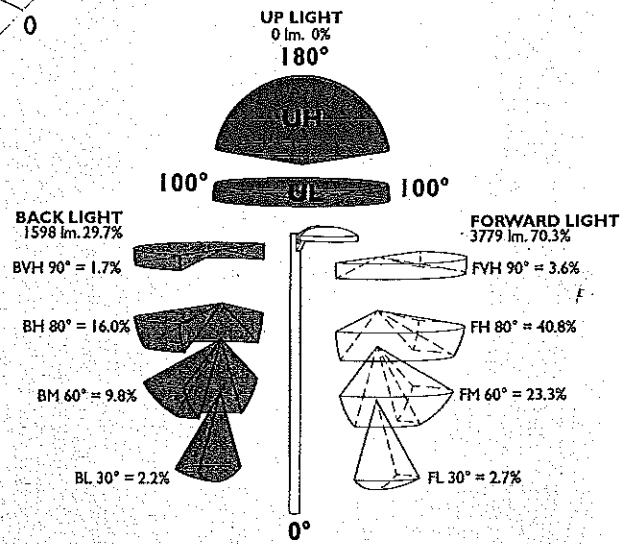

Type III - 120 LED

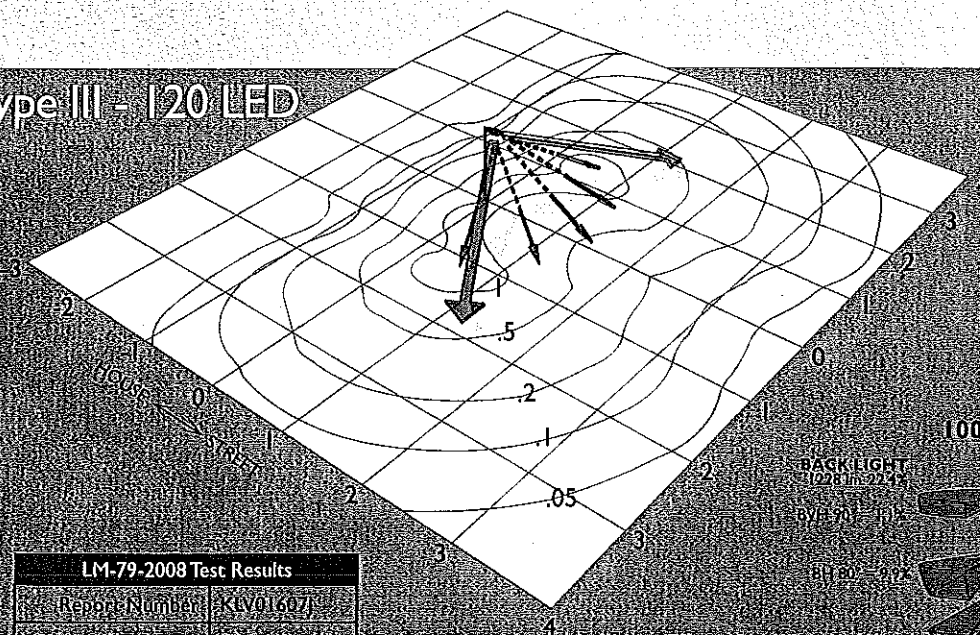

LM-79-2008 Test Results	
Report Number	KV016071
Mounting Height	20 feet
Light Dist. Type	Type III
Total Flux	4470 Lm.
System Watts	175W

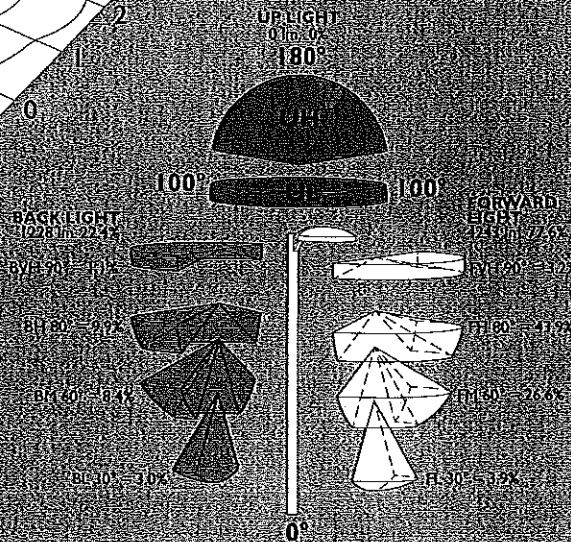

Small Specs

Large Specs

WP9SE
 Small LED
 60 LEDs
EPA: .52
 Maximum Weight:
 17 lbs.
 Maximum System
 Watts = 88 W

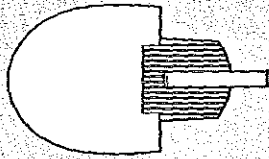

TOP

WP9LE
 Large LED
 120 LEDs
EPA: .95
 Maximum Weight:
 35 lbs.
 Maximum System
 Watts = 175 W

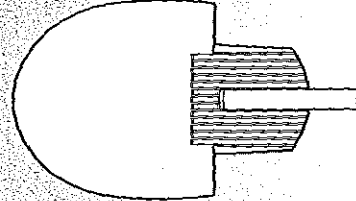

TOP

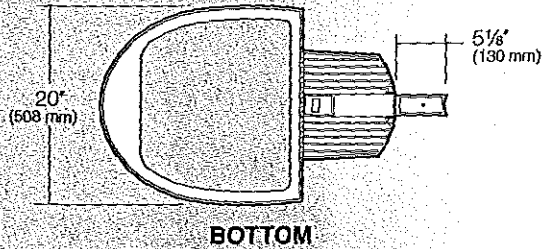
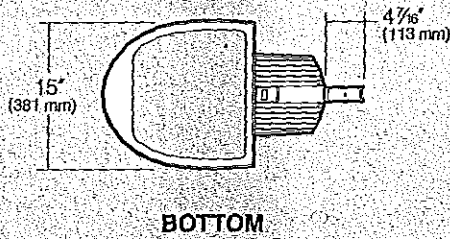
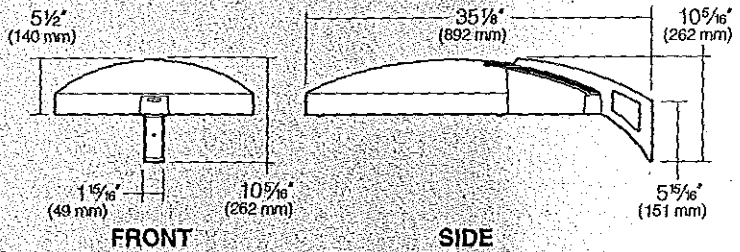
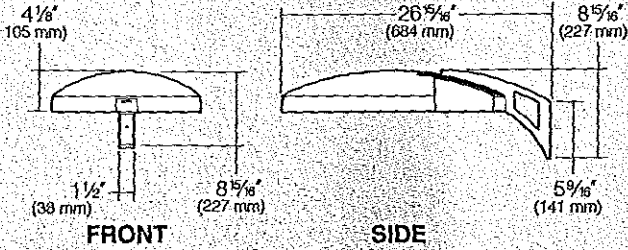

Specifications

HOUSING—The fixture is constructed from die-cast aluminum with integrated cooling fins. However, the die-cast aluminum housing will separate into electrical and optical compartments. A single die-cast aluminum compartment provides positive lock and seal of the optical chamber. A die-cast aluminum and welded die-cast parts seal the housing around the lens surface.

ELECTRONIC DRIVER—The driver is a high efficiency, compact, 100% die-cast aluminum with an integrated cooling fin. The driver is mounted on the side of the housing and provides die-cast mounting and removal from the fixture. All die-cast components are 6061-T6 aluminum and meet the requirements of the National Electrical Manufacturers Association (NEMA) for outdoor use.

TEMPERATURE—The fixture is designed to operate in a temperature range of -40°F to 140°F. The fixture is designed to operate in a temperature range of -40°F to 140°F.

OPTICAL—The fixture is designed to provide a beam of light that is adjustable. The fixture is designed to provide a beam of light that is adjustable. The fixture is designed to provide a beam of light that is adjustable.

CAUTION—The fixture is designed to provide a beam of light that is adjustable. The fixture is designed to provide a beam of light that is adjustable. The fixture is designed to provide a beam of light that is adjustable.

Listings and Ratings

UL	UL	1398	CE	RoHS	25°C Ambient
----	----	------	----	------	--------------

Kim brand and logo are trademarks of Kim brand.
 All other specifications without notice.

CUT SHEET #2



WPLED26/PC



JOB NAME: _____
 DATE: _____
 TYPE: _____

DESCRIPTION

LED 26 Watt Wallpacks

SPECIFICATIONS

Ambient Temperature

Suitable for use in 40C ambient temperatures.

California Title 24

WPLED complies with California Title 24 building and electrical codes.

Cold Weather Starting

The minimum starting temperature is -40°C

Color Accuracy

66 CRI

Color Stability

RAB LED products significantly exceed Energy Star Requirements for Chromatic Stability during LM-80 Testing.

Color Temperature (Nominal CCT)

5169 K (Daylight)

Color Uniformity

RAB's range of CCT (Correlated color temperature) follows the guidelines of the American National Standard for Specifications for the Chromaticity of Solid State Lighting (SSL) Products, ANSI C78.377-2008.

Country of Origin

Designed by RAB in New Jersey and assembled in Taiwan

Dark Sky Approved

The International Dark Sky Association has approved this product as a full cutoff, fully shielded luminaire.

Equivalency

The WPLED26 is Equivalent in delivered lumens to a 175W Metal Halide Wallpack.

Finish

Chip and fade resistant polyester powder coat finish.

Fixture Efficacy

61 Lumens per Watt

For use on LEED Buildings

IDA Dark Sky Approval means that this fixture can be used to achieve LEED Credits for Light Pollution Reduction.

GSA Schedule

This product is suitable for listing on the GSA Schedule of the US General Services in accordance with FAR Subpart 25.4

Green Technology

RAB LEDs are Mercury, Arsenic and UV free.

HID Replacement Range

The WPLED26 can be used to replace 150 - 200W Metal Halide Wallpacks based on delivered lumens.

Heatsink

Cast aluminum thermal management system for optimal heat sinking. The LPACK is designed for cool operation, most efficient output and maximum LED life by minimizing LED junction temperature.

LED Light Engine

Multi-chip 26W high output long life LED Driver Constant Current, 720mA, Class 2, 6 KV Surge Protection, 100V-277V, 50-60 Hz, 100-240V .4 Amps

Patents

The WPLED design is protected by U.S. PATENT D608,040 and patents pending in the U.S., Canada, China, Taiwan and Mexico.

Trade Agreements Act Compliant

This product is a product of Taiwan and a "designated country" end product that complies with the Trade Agreements Act.

DIMENSIONS

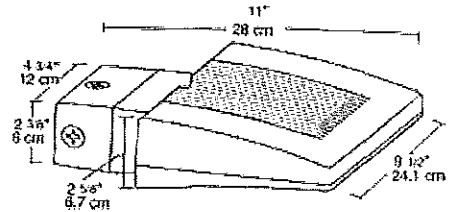

ORDERING INFORMATION

LED Lamp supplied with fixture	Total Watts	Lamp Type	Lamp Base	Ballast	Starting Amps/ Operating Amps				Input Watts	LAMP ANSI	Initial Lumens	Lamp Hours
					120V	208V	240V	277V				
	26	LED	Thermal	Constant Current	.4 A/.4 A	.4 A/.4 A	.4 A/.4 A	.4 A/.4 A	30.2	N/A	1816	50000
Factory Installed Options Add suffix to Catalog Number				Photocontrol for 277V (P62) Heatsink				Photocontrol for 120V (PC)				

Note: Specifications may change without notice

CUT SHEET #3

SLIM™ LED WALLPACK

Weight:
4.5 lbs.

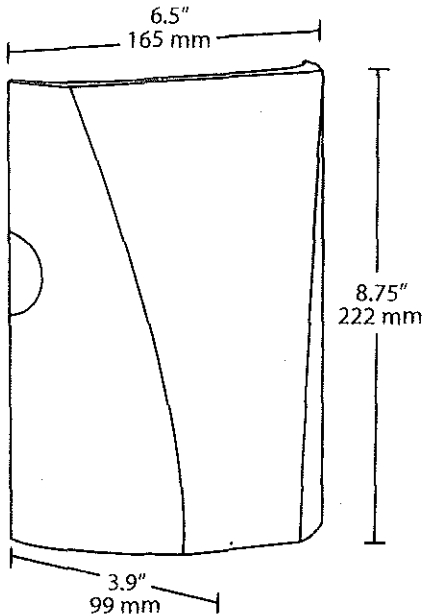

Catalog Numbers

SLIM12	12 Watts, Bronze, Cool Light
SLIM12W	12 Watts, White, Cool Light
SLIM12N	12 Watts, Bronze, Neutral Light
SLIM12NW	12 Watts, White, Neutral Light
SLIM12Y	12 Watts, Bronze, Warm Light
SLIM12YW	12 Watts, White, Warm Light

SLIM18	18 Watts, Bronze, Cool Light
SLIM18W	18 Watts, White, Cool Light
SLIM18N	18 Watts, Bronze, Neutral Light
SLIM18NW	18 Watts, White, Neutral Light
SLIM18Y	18 Watts, Bronze, Warm Light
SLIM18YW	18 Watts, White, Warm Light

SLIM26	26 Watts, Bronze, Cool Light
SLIM26W	26 Watts, White, Cool Light
SLIM26N	26 Watts, Bronze, Neutral Light
SLIM26NW	26 Watts, White, Neutral Light
SLIM26Y	26 Watts, Bronze, Warm Light
SLIM26YW	26 Watts, White, Warm Light

Specifications

UL Listing: Suitable for wet locations. Suitable for mounting within 4' of the ground.

LED: Multi-chip, long-life LED

Lifespan: 100,000-hour LED lifespan based on IES LM-80 results and TM-21 calculations

12W Driver: Constant Current, Class 2, 100-277V, 50/60 Hz., 4KV surge protection, 350mA, 100-240VAC: 0.3 - 0.15 Amps, 277VAC: 0.15 Amps, THD<20%, Power Factor: 99%

18W Driver: Constant Current, Class 2, 100-277V, 50/60 Hz., 4KV surge protection, 500mA, 100-240VAC: 0.3 - 0.15 Amps, 277VAC: 0.15 Amps, THD<20%, Power Factor: 99%

26W Driver: Constant Current, Class 2, 100-277V, 50/60 Hz., 6KV surge protection, 720mA, 100-277VAC: 0.4 Amps, THD≤20%, Power Factor: 99%

Cold Weather Starting: Minimum starting temperature is -40°F / -40°C

Ambient Temperature: Suitable for 40°C (104°F) ambient temperatures

Thermal Management: Superior heat sinking with internal Air-Flow fins

Housing: Precision die-cast aluminum housing

Mounting: Heavy-duty mounting bracket with hinged housing for easy installation

Lens: Tempered glass

Reflector: Specular thermoplastic

Gaskets: High-temperature silicone

Finish: Chip and fade resistant polyester powder coat finish

Color Stability: RAB LED performance exceeds industry standards for chromatic stability

Color Uniformity: RAB's range of CCT (Correlated Color Temperature) follows the guidelines of the American National Standard for Specifications for the Chromaticity of Solid State Lighting (SSL) Products, ANSI C78.377-2011.

Green Technology: Mercury and UV free, and RoHS compliant

IESNA LM-79 & LM-80 Testing: RAB LED luminaires have been tested by an independent laboratory in accordance with IESNA LM-79 and LM-80, and have received the Department of Energy "Lighting Facts" label.

Patents: The design of the SLIM™ is protected by patents pending in US, Canada, China, Taiwan and Mexico.

* Values shown for cool temperature. Visit rabweb.com for neutral and warm.



**IP66
RATING**



**RAB®
LIGHTING**
RABWEB.COM • 888 722-1000

SLIM™ LED WALLPACK

- Full Cutoff, Fully Shielded LED Wallpack
- Available in 12, 18 and 26 Watt Models
- 100,000-Hour LED Life

- DesignLights Consortium Qualification Pending
- Can be Used as Downlight or Uplight
- 5-Year Warranty

Easy installation

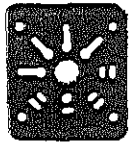

The universal junction box has knockouts to match every surface and recessed box we could find, or just screw it directly to the wall.

Electrical wiring is a dream with conduit entry from the back, sides and top.

A helpful third-hand rest for the fixture helps you finish your electrical connections safely and conveniently.

Integrated bubble level ensures every SLIM is installed plumb and true without any guesswork.

When you're ready to button it up, the guide-right screw simplifies the process and makes installation a snap.

SLIM™ 26

REPLACES 175W MH / Mounting Height up to 22' ft.

Input Watts @ 120V	31.4
Output Lumens	2648
Lumens per Watt	84
Color Accuracy (CRI)	68
Correlated Color Temp. (Nominal CCT)	5100K

Values shown for cool temperature. Visit rabweb.com for neutral and warm.

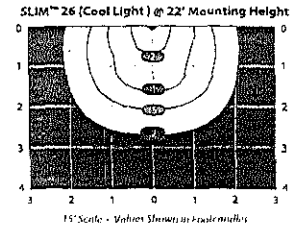

SLIM™ 18

REPLACES 100W MH / Mounting Height up to 14 ft.

Input Watts @ 120V	20.9
Output Lumens	1909
Lumens per Watt	91
Color Accuracy (CRI)	69
Correlated Color Temp. (Nominal CCT)	5100K

Values shown for cool temperature. Visit rabweb.com for neutral and warm.

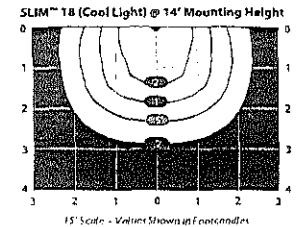

SLIM™ 12

REPLACES 70W MH / Mounting Height up to 8 ft.

Input Watts @ 120V	14.5
Output Lumens	1401
Lumens per Watt	97
Color Accuracy (CRI)	69
Correlated Color Temp. (Nominal CCT)	5100K

Values shown for cool temperature. Visit rabweb.com for neutral and warm.

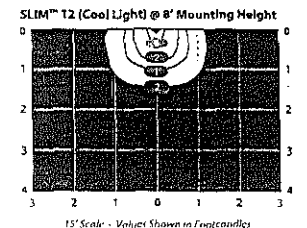

Cut SHEET #4

RAB
LIGHTING
WPLEDC52



JOB NAME: _____
DATE: _____
TYPE: _____

DESCRIPTION
LED 52 Watt Wallpacks

SPECIFICATIONS

Color Temperature (Nominal CCT)
5000k

Fixture Efficacy
57 Lumens per Watt

Surge Protection
6 KV

Color Accuracy
67 CRI

Heatsink
Cast aluminum thermal management system for optimal heat sinking. The WPLED is designed for cool operation, most efficient output and maximum LED life by minimizing LED junction temperature.

Finish
Chip and fade resistant polyester powder coat finish.

Country of Origin
Designed by RAB in New Jersey and assembled in the USA by IBEW Local 3

Mounting
Die-cast aluminum wall bracket with (5) 1/2" conduit openings with plugs. Two-piece bracket with tether for ease of installation and wiring.

Arm
Die-cast aluminum with wiring access plate.

LEDs
Four (4) multi-chip, 13W high-output, long-life LEDs

Gaskets
High temperature silicone.

Reflector
Hydroformed aluminum designed for maximum efficiency.

Housing
Precision die cast aluminum housing, lens frame.

Warranty
RAB LED fixtures give you peace of mind because both the fixture and light engine components are backed by RAB's 5 Year Warranty. For more information,

IESNA LM-79 & IESNA LM-80 Testing
RAB LED luminaires have been tested by an independent laboratory in accordance with IESNA LM-79 and 80, and have received the Department of Energy "Lighting Facts" label.

Color Stability
RAB LEDs exceed industry standards for chromatic stability.

Color Uniformity
RAB's range of CCT (Correlated color temperature) follows the guidelines of the American National Standard for Specifications for the Chromaticity of Solid State Lighting (SSL) Products, ANSI C78.377-2008.

Ambient Temperature
Suitable for use in 40C ambient temperatures.

UL Listing
Suitable for wet locations as a downlight.

Patents
The WPLED design is protected by patents pending in the U.S., Canada, China, Taiwan and Mexico.

Replacement
The WPLED52 replaces 250W HID Wallpacks.

Cold Weather Starting
The minimum starting temperature is -40F/-40C

California Title 24
WPLED complies with California Title 24 building and electrical codes.

DIMENSIONS

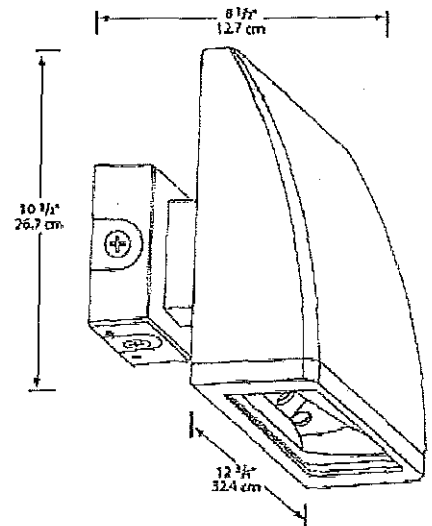

ORDERING INFORMATION

LED Lamp supplied with fixture	Total Watts	Lamp Type	Lamp Base	Ballast	Starting Amps/ Operating Amps				Input Watts	LAMP ANSI	Initial Lumens	Lamp Hours
					120V	208V	240V	277V				
	52	LED	Therm al	Constant Current	.8 A/.8 A	.8 A/.8 A	.8 A/.8 A	.8 A/.8 A	60.0	N/A	3434	50000

Factory Installed Options
Add suffix to Catalog Number

Photocontrol for 277V (P2)
Photocontrol for 120V (IPC)
REVISION

Note: Specifications may change without notice



Date : 22 Nov 2011
 Title : City of Portland
 Desc : 7.5 Degree Cutoff Wallpack

Luminaire *WPLED52*

IES Filename ITL68564.IES

Description : WPLED52 / ALED52 - 7.5-DEGREE TILT
 CAST FINNED METAL HOUSING, FOUR CIRCUIT
 BOARDS EACH WITH
 FOUR WHITE MULTI-CHIP LIGHT EMITTING

For : Kathy Alves
 By : Stephen Russell

Light Loss Factor : 1.00
 Number of Lamps : 4
 Lamp Lumens : -1 lms
 Luminaire Watts : 60 W



Scale: feet

Arrangement Magnification: 100 %

