

City of Portland, Maine - Building or Use Permit Application
 389 Congress Street, 04101 Tel: (207) 874-8703, Fax: (207) 874-8716

PERMIT ISSUED

Permit No: 02-0357
 Issue Date: APR 30 2002
 CBL: 353 A016001

Location of Construction: 27 Allison Ave	Owner Name: Pedro Philip J	Owner Address: 27 Allison Ave	Phone: 878-5032
Business Name:	Contractor Name: Sebago Lake Pools	Contractor Address: 629 Lower Main St. Gorham	Phone: 2078561000
Lessee/Buyer's Name	Phone:	Permit Type: Swimming Pools	Zone: R2

Past Use: Single Family	Proposed Use: Single Family	Permit Fee: \$163.00	Cost of Work: \$19,955.00	CEO District: 2
		FIRE DEPT: <input type="checkbox"/> Approved <input type="checkbox"/> Denied	INSPECTION: Use Group: R-4 Type: ACC	

Proposed Project Description:
 Install In-Ground 18'x38' Pool w/54'x28' Decking/Platforms

Signature: _____ Signature: *[Signature]* 4/29/02

PEDESTRIAN ACTIVITIES DISTRICT (P.A.D.)

Action: Approved Approved w/Conditions Denied

Signature: _____ Date: _____

Permit Taken By: gad	Date Applied For: 04/12/2002	Zoning Approval
-------------------------	---------------------------------	------------------------

<p>1. This permit application does not preclude the Applicant(s) from meeting applicable State and Federal Rules.</p> <p>2. Building permits do not include plumbing, septic or electrical work.</p> <p>3. Building permits are void if work is not started within six (6) months of the date of issuance. False information may invalidate a building permit and stop all work..</p>	<p>Special Zone or Reviews</p> <p><input type="checkbox"/> Shoreland</p> <p><input type="checkbox"/> Wetland</p> <p><input type="checkbox"/> Flood Zone</p> <p><input type="checkbox"/> Subdivision</p> <p><input type="checkbox"/> Site Plan</p> <p>Maj <input type="checkbox"/> Minor <input type="checkbox"/> MM <input type="checkbox"/></p> <p>Date: 4/29/02</p> <p><i>[Signature]</i> OK</p>	<p>Zoning Appeal</p> <p><input type="checkbox"/> Variance</p> <p><input type="checkbox"/> Miscellaneous</p> <p><input type="checkbox"/> Conditional Use</p> <p><input type="checkbox"/> Interpretation</p> <p><input type="checkbox"/> Approved</p> <p><input type="checkbox"/> Denied</p> <p>Date: _____</p>	<p>Historic Preservation</p> <p><input type="checkbox"/> Not in District or Landmark</p> <p><input type="checkbox"/> Does Not Require Review</p> <p><input type="checkbox"/> Requires Review</p> <p><input type="checkbox"/> Approved</p> <p><input type="checkbox"/> Approved w/Conditions</p> <p><input type="checkbox"/> Denied</p> <p>Date: _____</p>
---------------------------------------------------------------------------------------------------------------------------------------------------------------------------------------------------------------------------------------------------------------------------------------------------------------------------------------------------------------------------------------	---------------------------------------------------------------------------------------------------------------------------------------------------------------------------------------------------------------------------------------------------------------------------------------------------------------------------------------------------------------------------------------------------------------	----------------------------------------------------------------------------------------------------------------------------------------------------------------------------------------------------------------------------------------------------------------------------------------------------------------------	------------------------------------------------------------------------------------------------------------------------------------------------------------------------------------------------------------------------------------------------------------------------------------------------------------------------------------------------------------------

CERTIFICATION

I hereby certify that I am the owner of record of the named property, or that the proposed work is authorized by the owner of record and that I have been authorized by the owner to make this application as his authorized agent and I agree to conform to all applicable laws of this jurisdiction. In addition, if a permit for work described in the application is issued, I certify that the code official's authorized representative shall have the authority to enter all areas covered by such permit at any reasonable hour to enforce the provision of the code(s) applicable to such permit.

SIGNATURE OF APPLICANT	ADDRESS	DATE	PHONE
RESPONSIBLE PERSON IN CHARGE OF WORK, TITLE		DATE	PHONE

Application ID Number: 2-0357

Delete Save Close

Department: Building

Status: Approved with Conditions

Reviewer: Mike Nugent

Comments:

[Empty text box for comments]

Approval Date: 04/29/2002

Given On Date: 04/18/2002

OK to Issue Permit

Name: Mike Nugent

Date: 04/29/2002

Date 2: [Empty]

Conditions Section:

Add New Condition From

Add New Condition

Delete Condition

Must Comply w/ Section 421. 1999 BOCA Code

[Large empty text area for conditions]

Create Date: 04/16/2002 By: gad

Update Date: 04/29/2002 By: mjn

Application ID Number: 2-0357

Delete

Save

Close

Department: Zoning

Status: Approved with Conditions

Reviewer

Mike Nugent

Comments:

[Empty text area for comments]

Approval Date

04/29/2002

Given On Date

04/18/2002

OK to Issue Permit

Name

Mike Nugent

Date

04/29/2002

Date 2

[Empty date field]

Conditions Section:

Add New Condition From

Add New Condition

Delete Condition

Must meet the setbacks as specified in Section 14-432/Zoning



Create Date: 04/16/2002

By

gad

Update Date:

04/29/2002

By

mjn

Delete Schedule Add End Print Permit Print C of O Print Insp

Prmt Constr Type New Num1 2
Permit Nbr 02-0357 Location of Construction 27 Allison Ave Appl. Date
Status Hold Permit Type Swimming Pools Issue Date
CBL 353 A016001 Territory Nbr 2 Estimated Cost \$19,955.00 Date Closed

Comment Date Comment Add Delet Save

04/22/2002 HOLD Requested additional info from Installer w/ regard to slopes and fencing

Name mjn Follow Up Date Completed

CreatedBy gad CreateDate 04/16/2002 ModBy mjn ModDate 04/22

Memorandum

To: Sebago Lakes Pools (fax 856-1164)
CC:
From: Mike Nugent/Manager of Inspection Services
Date: 04/22/2002
Re: 27 Allison Ave. (353 A015)

Please find attached a copy of Section 421 of the 1999 BOCA code. Please provide compliance data for the 18' x 38' in-ground pool proposed for the above location.

02-0357

All Purpose Building Permit Application

If you or the property owner owes real estate or personal property taxes or user charges on any property within the City, payment arrangements must be made before permits of any kind are accepted.

Location/Address of Construction: <u>27 Allison Ave</u>		
Total Square Footage of Proposed Structure <u>1856</u>	Square Footage of Lot <u>12,800</u>	
Tax Assessor's Chart, Block & Lot Chart# <u>353</u> Block# <u>A</u> Lot# <u>16</u>	Owner: <u>Philip Pedro</u>	Telephone: <u>878-5032</u>
Lessee/Buyer's Name (If Applicable)	Applicant name, address & telephone: <u>Philip Pedro</u> <u>27 Allison Ave</u> <u>878-5032</u>	Cost Of Work: <u>\$19,955</u> Fee: \$ <u>103-</u>
What size is the pool: <u>18' x 38'</u> Above or below ground: <u>below</u>		
Dimensions of decking and/or platforms: <u>54 x 28</u>		
Contractor's name, address & telephone: <u>Sebago Lake Pools 629 Lower Main St</u> <u>Gerham, ME 04038</u> <u>856-1000</u> <u>1164</u>		
Who should we contact when the permit is ready: <u>Philip Pedro</u>		
Mailing address: <u>27 Allison Ave</u> <u>Portland, ME 04103</u>		
We will contact you by phone when the permit is ready. You must come in and pick up the permit and review the requirements before starting any work, with a Plan Reviewer. A stop work order will be issued and a \$100.00 fee if any work starts before the permit is picked up. PHONE: 878-5032 <u>WORK 844-7118</u>		

IF THE REQUIRED INFORMATION IS NOT INCLUDED IN THE SUBMISSIONS THE PERMIT WILL BE AUTOMATICALLY DENIED AT THE DISCRETION OF THE BUILDING/PLANNING DEPARTMENT, WE MAY REQUIRE ADDITIONAL INFORMATION IN ORDER TO APPROVE THIS PERMIT.

I hereby certify that I am the Owner of record of the named property, or that the owner of record authorizes the proposed work and that I have been authorized by the owner to make this application as his/her authorized agent. I agree to conform to all applicable laws of this jurisdiction. In addition, if a permit for work described in this application is issued, I certify that the Code Official's authorized representative shall have the authority to enter all areas covered by this permit at any reasonable hour to enforce the provisions of the codes applicable to this permit.

Signature of applicant: <u>[Signature]</u>	Date: <u>4-7-02</u>
--------------------------------------------	---------------------

This is NOT a permit; you may not commence ANY work until the permit is issued. If you are in a Historic District you may be subject to additional permitting and fees with the Planning Department on the 4th floor of City Hall

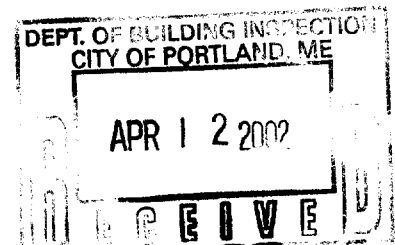

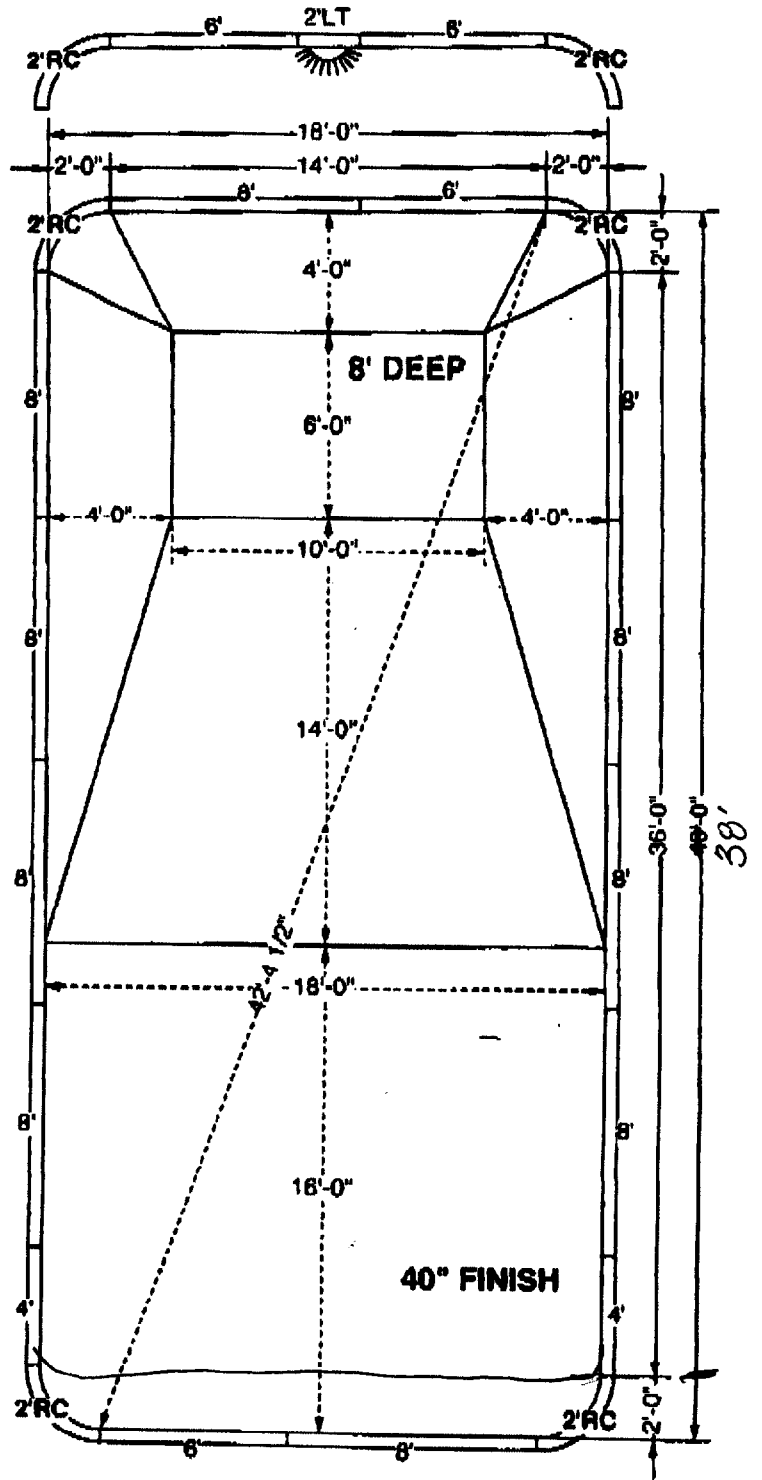
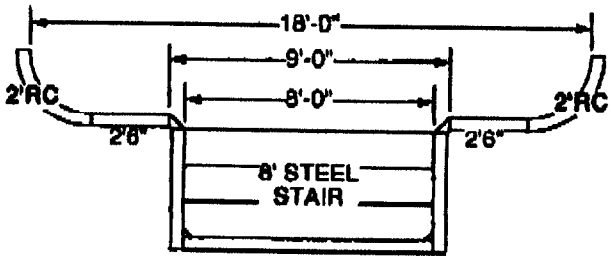
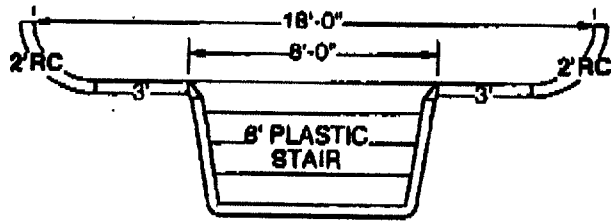

⚠ DANGER

NO DIVING IN SHALLOW END OF POOL



DIVING MAY CAUSE PERMANENT BLINDNESS, PARALYSIS OR DEATH
 NOTE: These diagrams comply with the National Fire and Pool Protection Association standards for residential pools. Material is 1/2" x 1/2" DIME, 1/2" x 1/2" SMALL DIME. It shows means of escape and is to be used with other pool safety devices. No structure and no other pool. For information concerning pool safety products, visit National Fire and Pool Protection Association website at www.nfpfa.org or call 1-800-255-2552.

Date: 12/09	 The Pool Depot, Inc.™ Number One in Quality and Service Forbes Road Newtown Industrial Park Newtown, PA 17057 PHONE (800)858-1455 FAX (800)585-0222
Title: Rectangle 18' x 40' 2' RC 38'	
Drafter: JLC 2936	Area: 720 sq. ft. Perimeter: 112' 6 3/4" NSPI Type II WA= 32" ±3"
File Name: tpd/RECT1840-2	
Template #: 59319	
WE DELIVER POOL KITS FASTER!	

Pool Gate Latch

Phil Pedro
27 Allison Ave
878-5032

Gate will be 3 feet wide, with a padlock latch 6 inches from the top of the Gate/fence, which will be 5 feet (60") in height.

Gate will be locked when not in use.

This is a safety latch along with padlock when not in ~~use~~ use

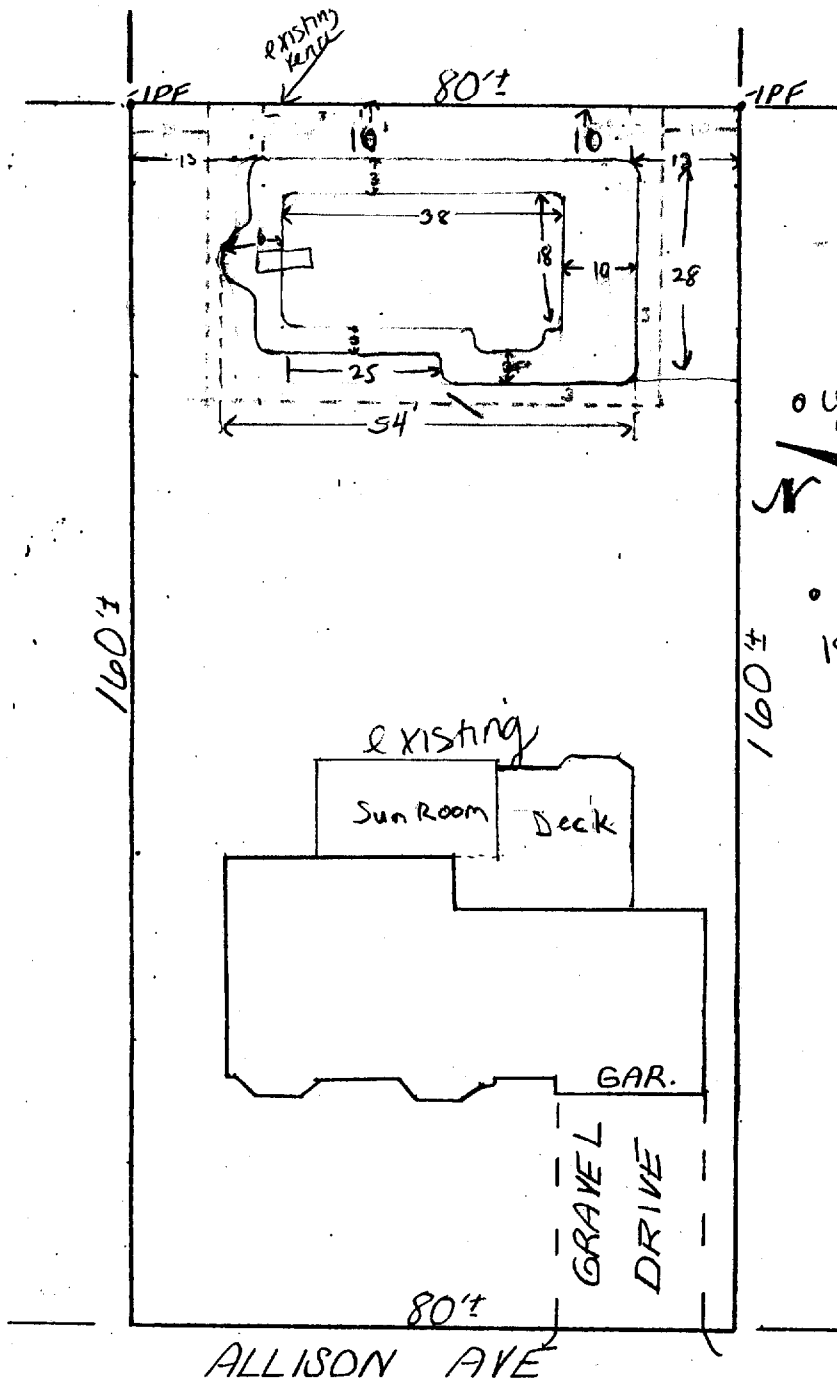

5' vinyl chain link fence
 yellow: cement walk
 rear setback is 10' from water



I CERTIFY TO THE BOSTON FIVE MORTGAGE CORP. & TICOR TITLE INSURANCE CO. THAT THIS PLAN DEPICTS THE RESULTS OF A CURRENT EXAMINATION OF THE PREMISES DESCRIBED IN RECORD BOOK 8091 PAGE 236 OF THE CUMBERLAND REGISTRY OF DEEDS AND THAT ALL EASEMENTS, ENCROACHMENTS AND BUILDINGS ARE LOCATED ON THE GROUND AS SHOWN HEREON.

- NOTES:
1. THIS PLAN WAS NOT MADE FROM AN INSTRUMENT SURVEY AND IS NOT FOR RECORDING PURPOSES. THE PLAN SHOWS THE CONDITIONS EXISTING AS OF THE DATE SHOWN HEREON. CERTIFICATION IS FOR MORTGAGE PURPOSES ONLY PROPERTY LINES AS SHOWN ARE APPARENT ONLY.
 2. THE MUNICIPALITY HAS DETERMINED THAT THE PREMISES CONFORMED WITH LOCAL ZONING ORDINANCES AT TIME OF CONSTRUCTION.
 3. IN ACCORDANCE WITH THE LOCAL MUNICIPALITY THE PREMISES DO NOT FALL WITHIN A FLOOD HAZARD ZONE.

MORTGAGE CERTIFICATION SKETCH FOR
 PHILIP PEDRO & LISA PEDRO
 27 ALLISON AVE
 PORTLAND, ME

OCTOBER 19 1989 SCALE: 1" = 10'

PREPARED BY: A.W.I. ENGINEERING CO. W. SCARBOROUGH, MAINE

Power-Flo™ II Pumps

ABOVE-GROUND POOL PUMP SERIES

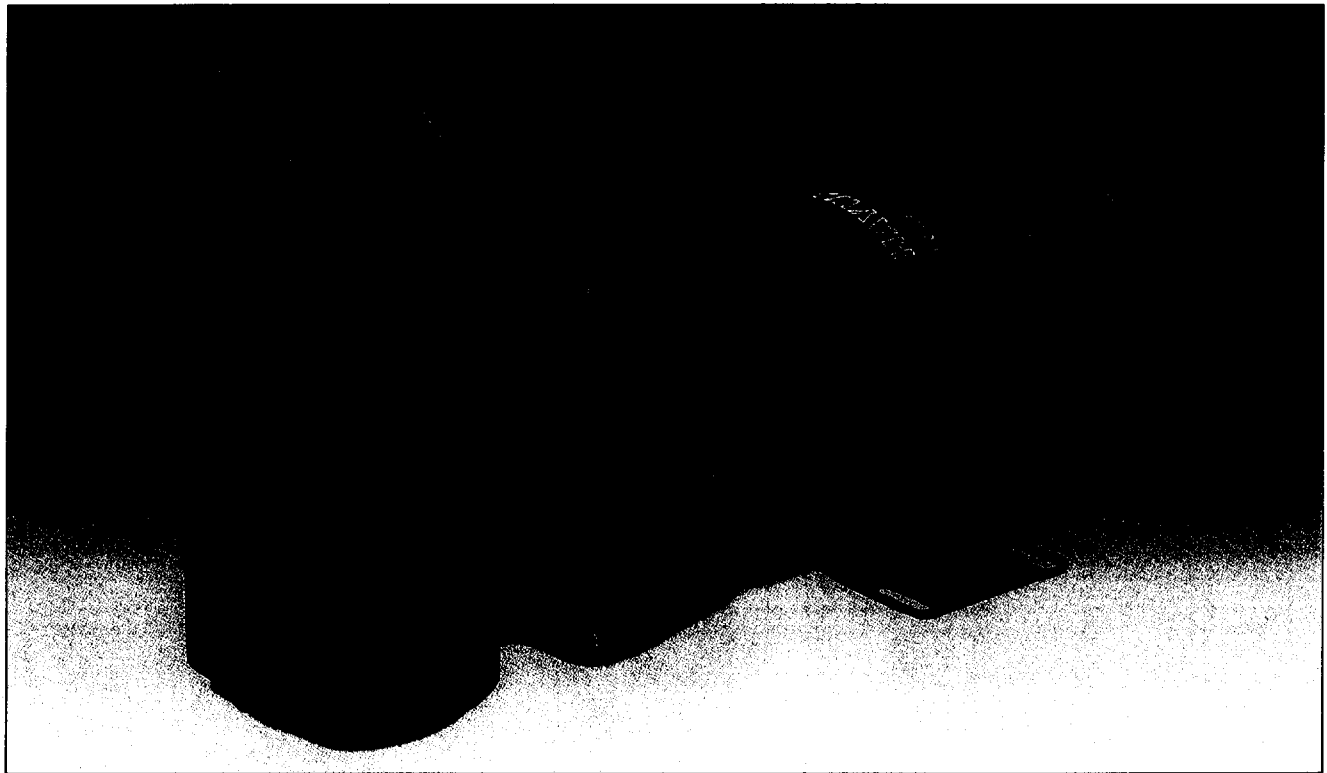

■ Power-Flo II: high performance and quiet operation.

The Power-Flo II is a versatile, high-performance self-priming pump designed to meet the varying specifications of mid-sized in-ground, above-ground and on-ground swimming pools.

The Power-Flo II incorporates features such as a massive 118 cubic centimeter strainer basket, an energy efficient motor with stainless steel shaft,

and a quick-release "see-thru" strainer cover. Features usually found only on higher priced in-ground pumps.



Durable and economical, the Power-Flo II continues to set the standard for value and performance in pumps.



HAYWARD®
America's #1 Pool Water Systems.

Perflex®

EXTENDED-CYCLE DE FILTER SERIES

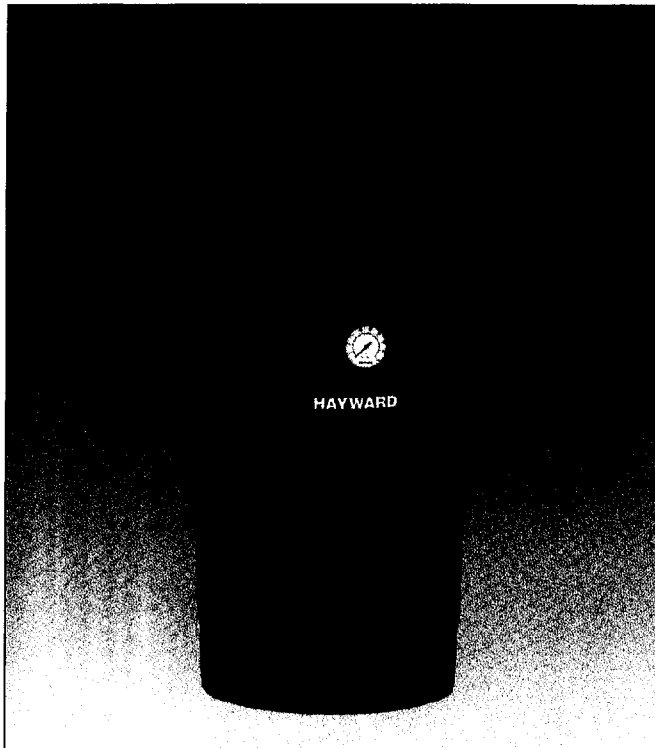

■ Perflex EC75 basic filter: for clean, sparkling pools.

The Perflex Extended-Cycle DE filter series cleans pools fast — removing particles as small as one micron the first time through. That's because Perflex incorporates a patented Flex-Tube™ design that works in combination with DE (diatomaceous earth) filter powder to produce the clearest, most sparkling water possible.



The exclusive Perflex Extended-Cycle gives you long filter cycles between cleaning — up to eight weeks depending on pool size and use. Because the same filter powder is used over

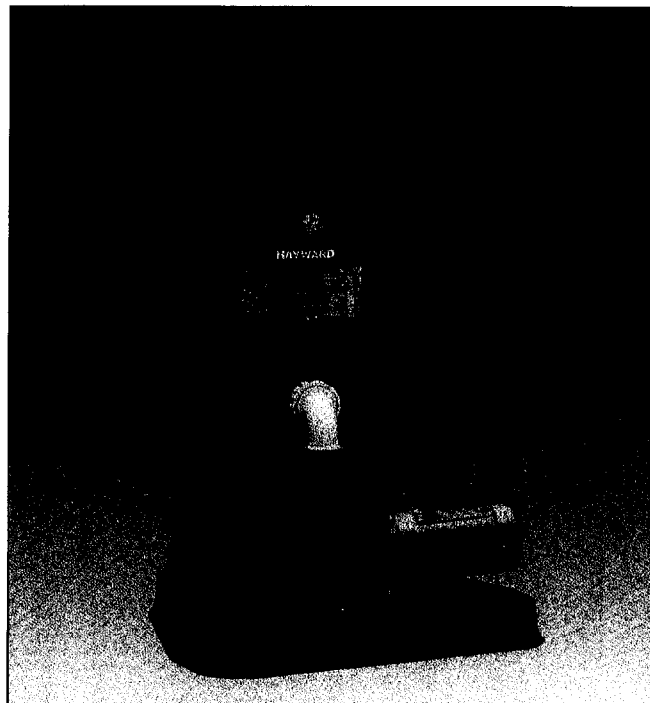

■ Perflex System III — select the filter system that's just right for your pool. Shown complete with a Perflex EC65 filter, Hayward Super Pump® and EC65BLP mounting base.

and over again, Perflex is a real work saver. And, it only takes minutes to extend the cycle. Perflex filters stretch your dollars too! Since Perflex cleans without backwashing, you save hundreds of gallons of treated pool water. Plus, Perflex saves on electricity because its



efficient design offers less resistance to flow and produces more filtered water with less pump horsepower.

Enjoy your pool more. Step up to Perflex today.

HAYWARD®
America's #1 Pool Water Systems.

EXTENDED-CYCLE DE FILTERS

Perflex® Extended-Cycle DE Filters

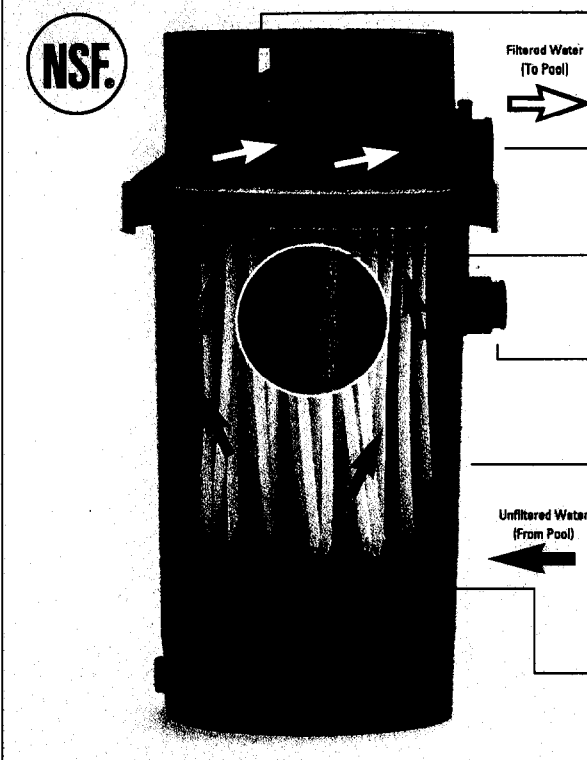

NSF.

Filtered Water (To Pool) →

Unfiltered Water (From Pool) ←

Bump Handle. An exclusive Perflex feature. It activates the mechanism causing the Flex-Tubes to instantly and uniformly clean themselves of dirt and filter powder.

Self Venting. As filtered water is returned to the pool, Perflex filters automatically expel any air that may be present in the system.

Flex-Tubes. The proven patented filter elements that efficiently reuse the filter powder and dirt mixture forming a fresh filtering surface.

Combination Pressure Gauge and Threaded Inspection/Service Port. Easy to read and remove when filter needs cleaning.

Heavy Duty Filter Tank. Injection-molded of high-strength Duralon™ for dependable, corrosion-free performance.

Check Valve. This integral valve automatically prevents system backflow whenever the pump is off.

Mixing Chamber. Engineered to produce a uniform, high velocity mixing of the filter powder and dirt that is removed from the Flex-Tubes by "Bumping".

Here's How It Works. Perflex filters use diatomaceous earth filter powder (commonly called D.E.) which will remove particles as small as one micron, and is the most efficient dirt remover known. It will even remove microscopic dust and pollen. Unfiltered water enters through the bottom connection in the filter tank, flows upward through the Flex-Tubes, and returns to the pool via the outlet in the filter head. When the filter is initially started, diatomite filter powder is fed into the system, usually through the skimmer. This is precoating. As the water passes through the Flex-Tubes, the filter powder is automatically deposited on the outside of the Flex-Tubes, forming the working "filter surface". Similarly, dirt in the water is stopped on the surface of the filter powder. Eventually, the accumulated dirt causes the filter pressure to rise and flow to diminish. This is when ordinary filters need backwashing – **but not Perflex**. Simply activate the Perflex "Bump" handle, and within a minute, flow and pressure are back to normal.

Specifications – Perflex Extended-Cycle DE Filters

FILTER TYPE:	Extended-Cycle Diatomite, EC65 or EC75
FILTER TANK:	Injection-Molded Duralon™
FILTER ELEMENTS:	Dacron Flex-Tubes (120)
FASTENINGS:	Stainless Steel
PERFORMANCE RANGE:	30 - 68 GPM (EC65); 35 - 80 GPM (EC75)
DIMENSIONS:	21" W x 31" H (533 mm x 787 mm)

Performance Data

MODEL NUMBER	EFFECTIVE FILTRATION AREA	DESIGN FLOW RATE*	TURNOVER (GALS.)		DE REQUIRED
			8 Hr.	10 Hr.	
EC65	34 sq. ft.	68 GPM	32,640	40,800	6 lbs.
EC75	40 sq. ft.	80 GPM	38,400	48,000	7 lbs.

*Perflex Filters conserve electricity and perform best with medium head pumps. Hayward pumps are application matched to provide optimum filter performance.

No Backwash. When conventional filters need backwashing, Perflex only needs "Bumping". "Bumping" repositions the dirt within the filter so the flow of water is not impeded. This is called Regeneration, because flow and pressure are restored, extending the filter cycle. When the dirt-holding capacity of the Perflex filter is reached, cleaning is simple. Just "Bump" and drain.

HAYWARD®
America's #1 Pool Water Systems.

1-888-HAYWARD

www.haywardnet.com

©2000 Hayward Pool Products, Inc.

1593

ATTN: Mike Nugent

1 page TOTAL

2'LT

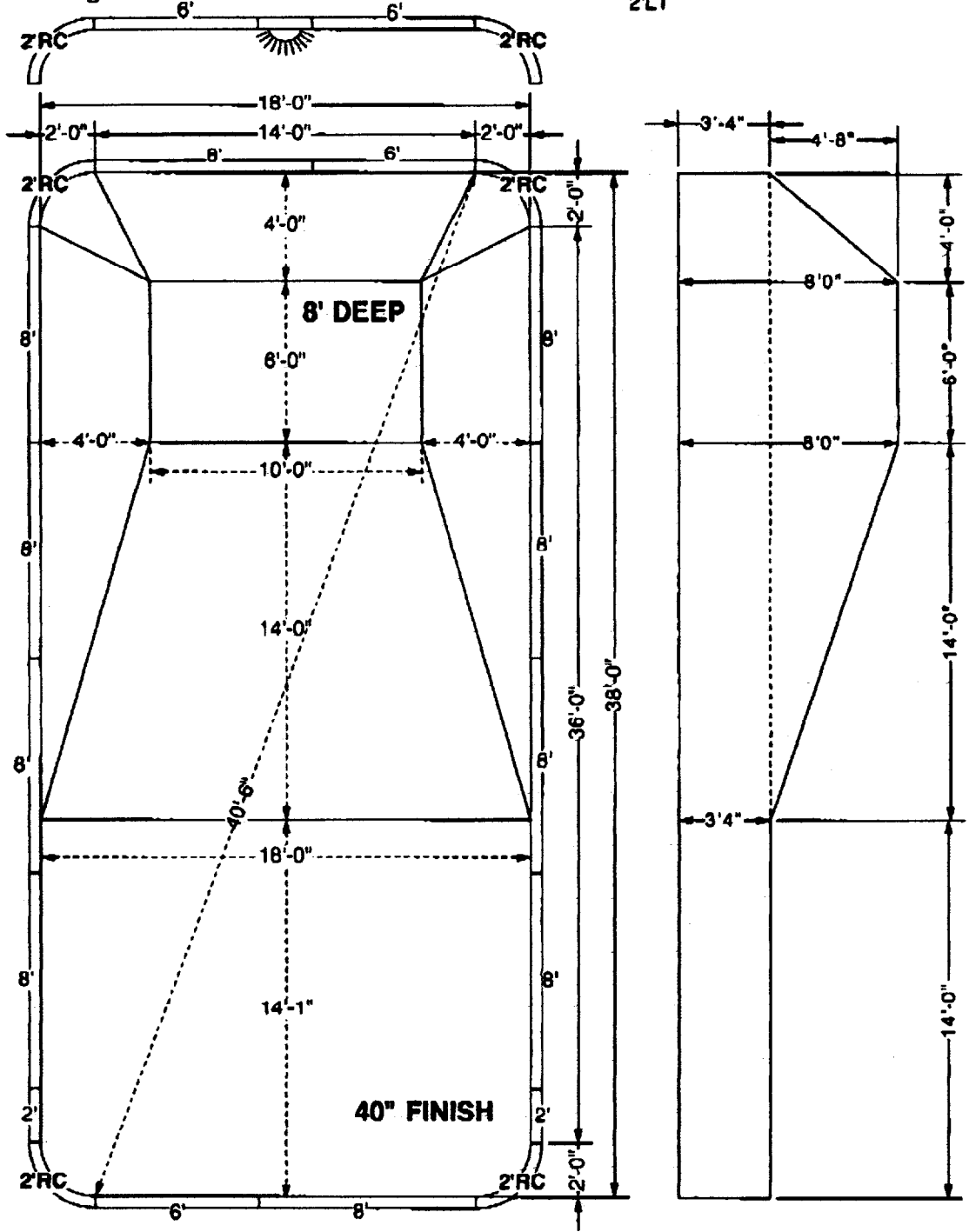

The Pool Depot Inc.

12 Forbes Road
 Newmarket, NH 03857
 800-992-5655
 FAX: 800-595-0222

Date: 04/02	 Pool Depot, Inc.™ Number One in Quality and Service. Forbes Road Newmarket Industrial Park Newmarket, NH 03857 PHONE (603)650-4465 FAX (800)595-0222
Title: Rectangle 18' x 38' 2' RC	
Drafter: RG 0402	Area: sq. ft.
File Name: tpd/sebago/pedron	Perimeter:
Template #:	NSPI Type
WE DELIVER POOL KITS FASTER!	



DANGER NO DIVING IN SHALLOW END OF POOL

WARNING: Diving may cause permanent injury, paralysis or death. Do not dive in shallow end of pool. Do not drink alcohol before swimming. Do not swim alone. Do not swim after eating. Do not swim if you are under the influence of any medication. Do not swim if you are pregnant. Do not swim if you have a heart condition. Do not swim if you have a respiratory condition. Do not swim if you have a back injury. Do not swim if you have a neck injury. Do not swim if you have a head injury. Do not swim if you have a fever. Do not swim if you are sick. Do not swim if you are tired. Do not swim if you are hungry. Do not swim if you are thirsty. Do not swim if you are hot. Do not swim if you are cold. Do not swim if you are wearing any jewelry. Do not swim if you are wearing any shoes. Do not swim if you are wearing any clothing. Do not swim if you are wearing any accessories. Do not swim if you are wearing any equipment. Do not swim if you are wearing any gear. Do not swim if you are wearing any supplies. Do not swim if you are wearing any tools. Do not swim if you are wearing any equipment. Do not swim if you are wearing any gear. Do not swim if you are wearing any supplies. Do not swim if you are wearing any tools.

BUILDING PERMIT INSPECTION PROCEDURES

Please call 874-8703 or 874-8693 to schedule your inspections as agreed upon

Permits expire in 6 months, if the project is not started or ceases for 6 months.

The Owner or their designee is required to notify the inspections office for the following inspections and provide adequate notice. Notice must be called in 48-72 hours in advance in order to schedule an inspection:

By initializing at each inspection time, you are agreeing that you understand the inspection procedure and additional fees from a "Stop Work Order" and "Stop Work Order Release" will be incurred if the procedure is not followed as stated below.

POP Pre-construction Meeting: Must be scheduled with your inspection team upon receipt of this permit. Jay Reynolds, Development Review Coordinator at 874-8632 must also be contacted at this time, before any site work begins on any project other than single family additions or alterations.

- N/A Footing/Building Location Inspection: Prior to pouring concrete
- N/A Re-Bar Schedule Inspection: Prior to pouring concrete
- N/A Foundation Inspection: Prior to placing ANY backfill
- POP Framing/Rough Plumbing/Electrical: Prior to any insulating or drywalling
- N/A Final/Certificate of Occupancy: Prior to any occupancy of the structure or use. NOTE: There is a ~~\$75.00~~ fee per inspection at this point.

Certificate of Occupancy is not required for certain projects. Your inspector can advise you if your project requires a Certificate of Occupancy. All projects DO require a final inspection

POP If any of the inspections do not occur, the project cannot go on to the next phase, REGARDLESS OF THE NOTICE OR CIRCUMSTANCES.

N/A CERTIFICATE OF OCCUPANCIES MUST BE ISSUED AND PAID FOR, BEFORE THE SPACE MAY BE OCCUPIED

[Signature]
Signature of applicant/designee

5-1-2002
Date

[Signature]
Signature of Inspections Official

5/1/02
Date

CBL: 353 A016 Building Permit #: 02 0357