

City of Portland, Maine - Building or Use Permit Application
 389 Congress Street, 04101 Tel: (207) 874-8703, Fax: (207) 874-8716

Permit No: 03-0617	PERMIT ISSUED	CBL: 353 E004001
-----------------------	----------------------	---------------------

Location of Construction: 50 Deering Run Dr	Owner Name: Rossi Louis J Sr &	Owner Address: 50 Deering Run Dr	Phone: 878-0373
Business Name:	Contractor Name: Darren Crawford	Contractor Address: 17 Myrtle St Westbrook	Phone: 2078540086
Lessee/Buyer's Name	Phone:	Permit Type: Additions - Dwellings	Zone: R2

Past Use: Single Family	Proposed Use: Single Family	Permit Fee: \$30.00	Cost of Work: \$1,000.00	CEO District: 2
----------------------------	--------------------------------	------------------------	-----------------------------	--------------------

Proposed Project Description: Build 15x20 deck in the rear	FIRE DEPT: <input type="checkbox"/> Approved <input type="checkbox"/> Denied	INSPECTION: Use Group: R3 Type: 5B Accessory BOCA 1999 Signature: JMB 6/5/03
	Signature: _____ PEDESTRIAN ACTIVITIES DISTRICT (P.A.D.) Action: <input type="checkbox"/> Approved <input type="checkbox"/> Approved w/Conditions <input type="checkbox"/> Denied Signature: _____ Date: _____	

Permit Taken By: jmb	Date Applied For: 06/05/2003	Zoning Approval
-------------------------	---------------------------------	------------------------

1. This permit application does not preclude the Applicant(s) from meeting applicable State and Federal Rules. 2. Building permits do not include plumbing, septic or electrical work. 3. Building permits are void if work is not started within six (6) months of the date of issuance. False information may invalidate a building permit and stop all work..	Special Zone or Reviews <input type="checkbox"/> Shoreland <input type="checkbox"/> Wetland <input type="checkbox"/> Flood Zone <input type="checkbox"/> Subdivision <input type="checkbox"/> Site Plan Maj <input type="checkbox"/> Minor <input type="checkbox"/> MM <input type="checkbox"/> Date: JMB 6/5/03	Zoning Appeal <input type="checkbox"/> Variance <input type="checkbox"/> Miscellaneous <input type="checkbox"/> Conditional Use <input type="checkbox"/> Interpretation <input type="checkbox"/> Approved <input type="checkbox"/> Denied Date: _____	Historic Preservation <input checked="" type="checkbox"/> Not in District or Landmark <input type="checkbox"/> Does Not Require Review <input type="checkbox"/> Requires Review <input type="checkbox"/> Approved <input type="checkbox"/> Approved w/Conditions <input type="checkbox"/> Denied Date: JMB
--	---	--	---

CERTIFICATION

I hereby certify that I am the owner of record of the named property, or that the proposed work is authorized by the owner of record and that I have been authorized by the owner to make this application as his authorized agent and I agree to conform to all applicable laws of this jurisdiction. In addition, if a permit for work described in the application is issued, I certify that the code official's authorized representative shall have the authority to enter all areas covered by such permit at any reasonable hour to enforce the provision of the code(s) applicable to such permit.

 SIGNATURE OF APPLICANT ADDRESS DATE PHONE

 RESPONSIBLE PERSON IN CHARGE OF WORK, TITLE DATE PHONE

City of Portland, Maine - Building or Use Permit

389 Congress Street, 04101 Tel: (207) 874-8703, Fax: (207) 874-8716

Permit No: 03-0617	Date Applied For: 06/05/2003	CBL: 353 E004001
------------------------------	--	----------------------------

Location of Construction: 50 Deering Run Dr	Owner Name: Rossi Louis J Sr &	Owner Address: 50 Deering Run Dr	Phone: () 878-0373
Business Name:	Contractor Name: Darren Crawford	Contractor Address: 17 Myrtle St Westbrook	Phone (207) 854-0086
Lessee/Buyer's Name	Phone:	Permit Type: Additions - Dwellings	

Proposed Use: Single Family	Proposed Project Description: Build 15x20 deck in the rear
---------------------------------------	--

Dept: Zoning	Status: Approved	Reviewer: Jeanine Bourke	Approval Date: 06/05/2003
Note:			Ok to Issue: <input checked="" type="checkbox"/>

Dept: Building	Status: Approved with Conditions	Reviewer: Jeanine Bourke	Approval Date: 06/05/2003
Note:			Ok to Issue: <input checked="" type="checkbox"/>
1) See notes on plans indicating specific span dimensions for joists and footers 2) Application approval based upon information provided by applicant. Any deviation from approved plans requires separate review and approval prior to work.			

This page contains a detailed description of the Parcel ID you selected. Press the **New Search** button at the bottom of the screen to submit a new query.

Current Owner Information

Card Number 1 of 1
Parcel ID 353 E004001
Location 50 DEERING RUN DR
Land Use SINGLE FAMILY

Owner Address ROSSI LOUIS J SR & JEANNETTE L JTS
 50 DEERING RUN DR
 PORTLAND ME 04103

Book/Page 7321/112
Legal 353-E-4
 DEERING RUN DR 48-54

 13162 SF

Valuation Information

Land	Building	Total
\$36,330	\$122,120	\$158,450

Property Information

Year Built 1987	Style Contemp	Story Height 2	Sq. Ft. 1678	Total Acres 0.303		
Bedrooms 3	Full Baths 2	Half Baths 1	Total Rooms 5	Attic None	Basement Full	

Outbuildings

Type	Quantity	Year Built	Size	Grade	Condition
-------------	-----------------	-------------------	-------------	--------------	------------------

Sales Information

Date	Type	Price	Book/Page
-------------	-------------	--------------	------------------

Picture and Sketch

Picture Sketch

[Click here](#) to view Tax Roll Information.

Any information concerning tax payments should be directed to the Treasury office at 874-8490 or e-mailed.





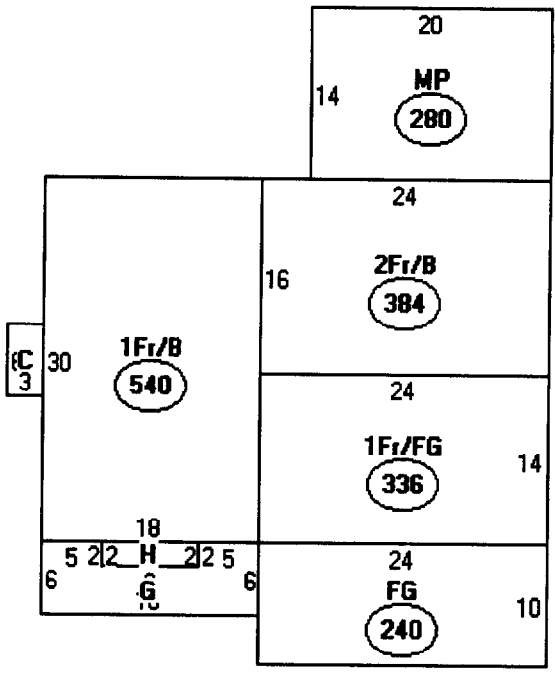

Descriptor/Area

- A: 2Fr/B 384 sqft
- B: 1Fr/B 540 sqft
- C: FBAY 18 sqft
- D: MP 280 sqft
- E: 1Fr/FG 336 sqft
- F: FG 240 sqft
- G: OFP 92 sqft
- H: FBAY 16 sqft

1906

300

2206

Lot = 13,182 SF

2,636.4

OK

Thurs. 3 Pm

All Purpose Building Permit Application

If you or the property owner owes real estate or personal property taxes or user charges on any property within the City, payment arrangements must be made before permits of any kind are accepted.

Location/Address of Construction: <u>50 Deering Run Dr. Portland</u>		
Total Square Footage of Proposed Structure <u>300 sq. ft.</u>	Square Footage of Lot <u>13187 sq. ft.</u>	
Tax Assessor's Chart, Block & Lot Chart# <u>353-E-4</u> Block# <u>(Book 7321 Page 112)</u> Lot#	Owner: <u>Louis ; Jeannette Rossi, Jr.</u>	Telephone: <u>878-0373</u>
Lessee/Buyer's Name (if Applicable) <u>N/A</u>	Applicant name, address & telephone: <u>Same as Owner</u>	Cost Of Work: \$ <u>1000.00</u> Fee: \$ <u>30.00</u>
Current use: <u>Owners Residence</u>		
If the location is currently vacant, what was prior use: _____		
Approximately how long has it been vacant: _____		
Proposed use: <u>Same</u>		
Project description: <u>Added Deck -> 15' x 20' single level deck, back of house</u>		
Contractor's name, address & telephone: <u>Darren Crawford</u>		
Who should we contact when the permit is ready: <u>Jeannette Rossi</u>		
Mailing address: Portland, ME <u>17 Myrtle St. Westbrook, Me. 04092</u> <u>Call</u>		
We will contact you by phone when the permit is ready. You must come in and pick up the permit and review the requirements before starting any work, with a Plan Reviewer. A stop work order will be issued and a \$100.00 fee if any work starts before the permit is picked up. PHONE: <u>854-0086</u>		

IF THE REQUIRED INFORMATION IS NOT INCLUDED IN THE SUBMISSIONS THE PERMIT WILL BE AUTOMATICALLY DENIED AT THE DISCRETION OF THE BUILDING/PLANNING DEPARTMENT, WE MAY REQUIRE ADDITIONAL INFORMATION IN ORDER TO APPROVE THIS PERMIT.

I hereby certify that I am the Owner of record of the named property, or that the owner of record authorizes the proposed work and that I have been authorized by the owner to make this application as his/her authorized agent. I agree to conform to all applicable laws of this jurisdiction. In addition, if a permit for work described in this application is issued, I certify that the Code Official's authorized representative shall have the authority to enter all areas covered by this permit at any reasonable hour to enforce the provisions of the codes applicable to this permit.

Signature of applicant: <u>Jeannette Rossi</u>	Date: <u>4/16/03</u>
--	----------------------

This is NOT a permit, you may not commence ANY work until the permit is issued. If you are in a Historic District you may be subject to additional permitting and fees with the Planning Department on the 4th floor of City Hall

(FUTURE STREET)

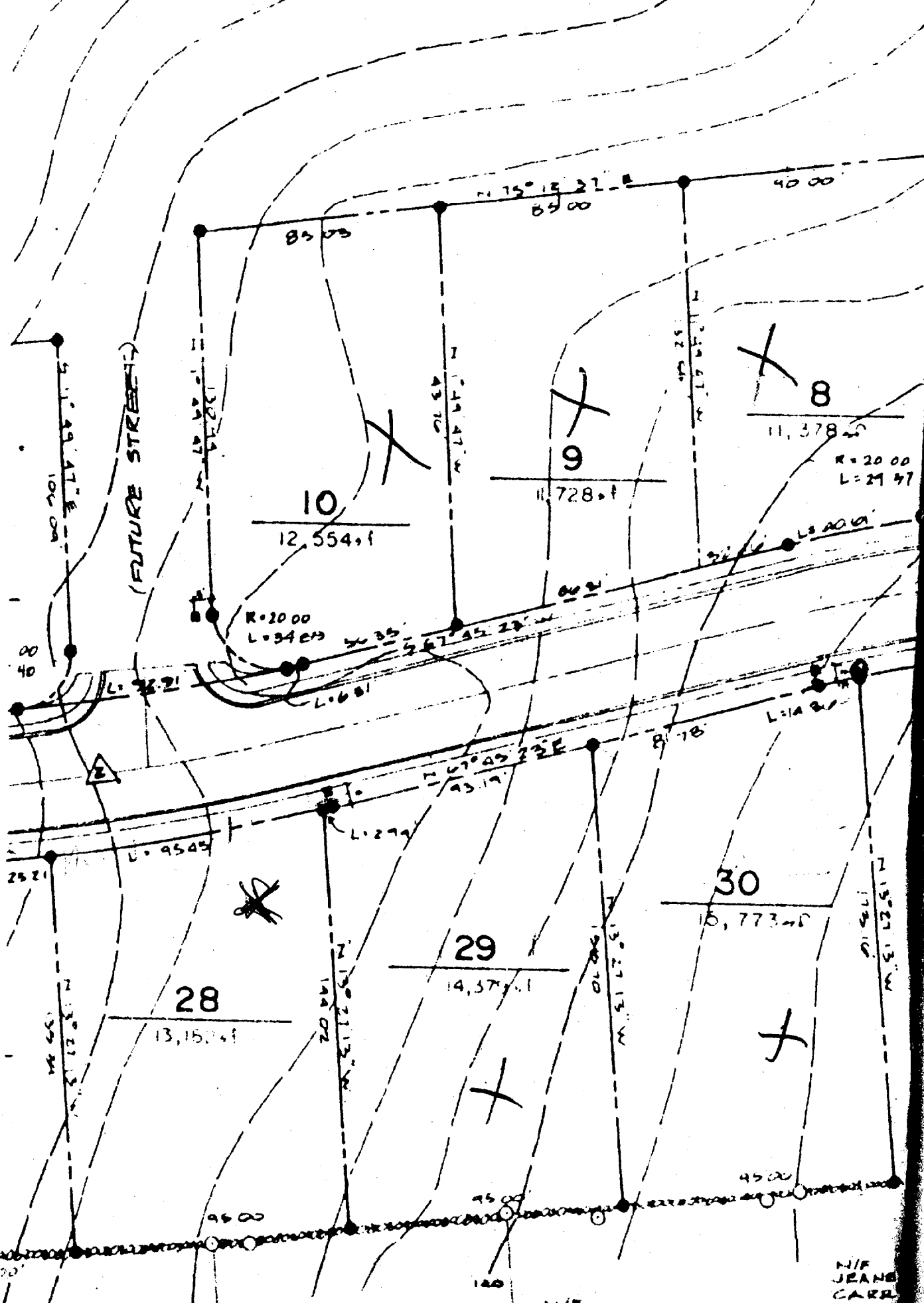

N/F
 ELAINE & THOMAS GOLDEN
 9042-270

N/F
 PHYLLIS WRNIDER
 4125-340

N/F
 JEANE
 CARR

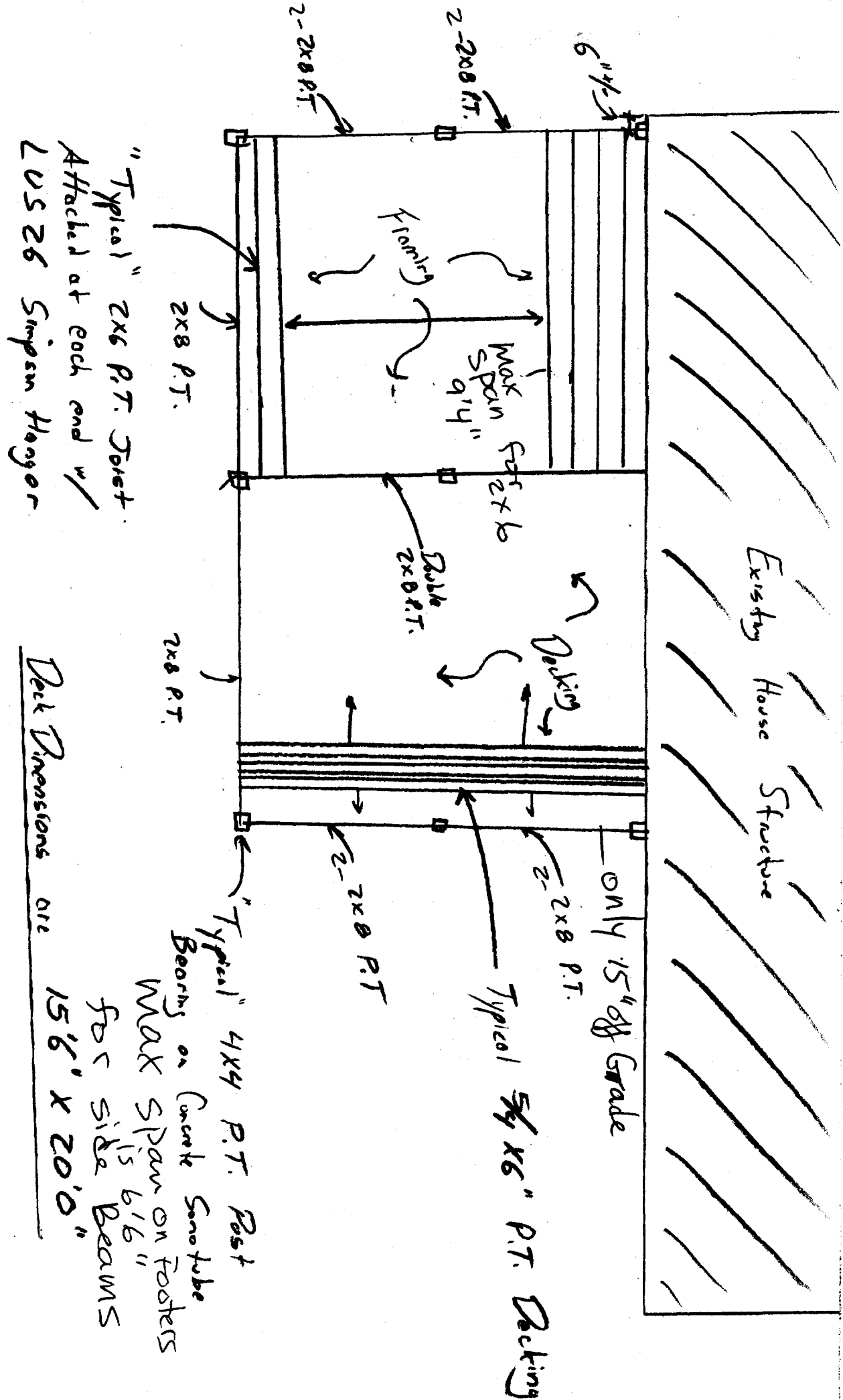

"Typical" 2x6 P.T. Joist
 Attached at each end w/
 LUS 26 Simpson Hanger

Deck Dimensions are
 15'6" x 20'0"
 Typical 4x4 P.T. Post
 Bearing on Concrete Sonotube
 MAX SPAN ON FOOTERS
 FOR SIDE BEAMS
 15'6" x 20'0"

Deck Framing & Docking Plan

Not to Scale

50 Dering Run Dr.
 Portland, Me. 04103

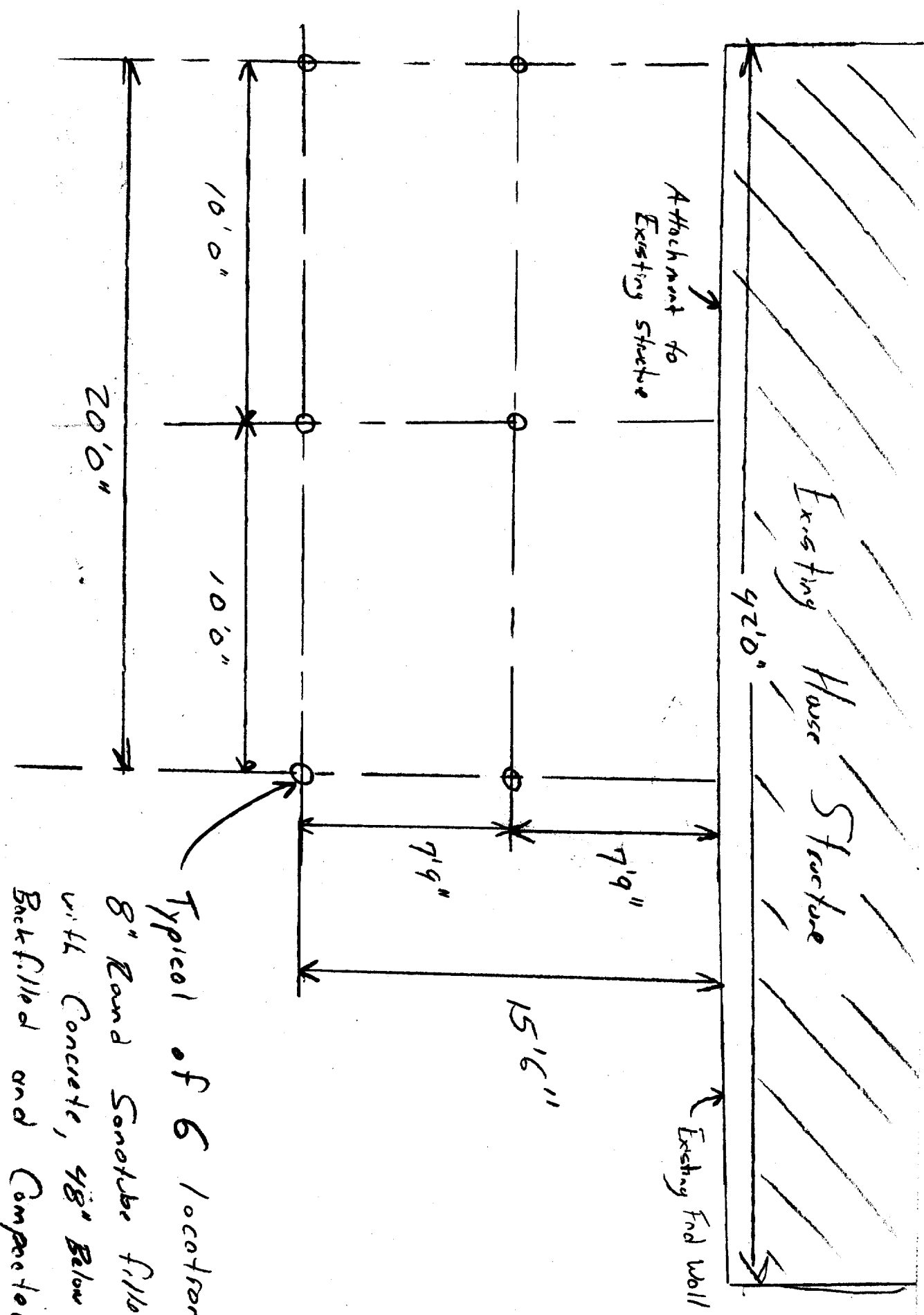

Attachment to Existing Structure

Existing House Structure

42'0"

Existing Fnd Wall

10'0"

10'0"

20'0"

7'9"

7'9"

15'6"

Typical of 6 locations
 8" Round Sonotube filled
 with Concrete, 48" Below Grade
 Backfilled and Compacted

New Deck Foundation Plan

Not to Scale

50 Perry Run Dr.
 Portland, Me. 04123

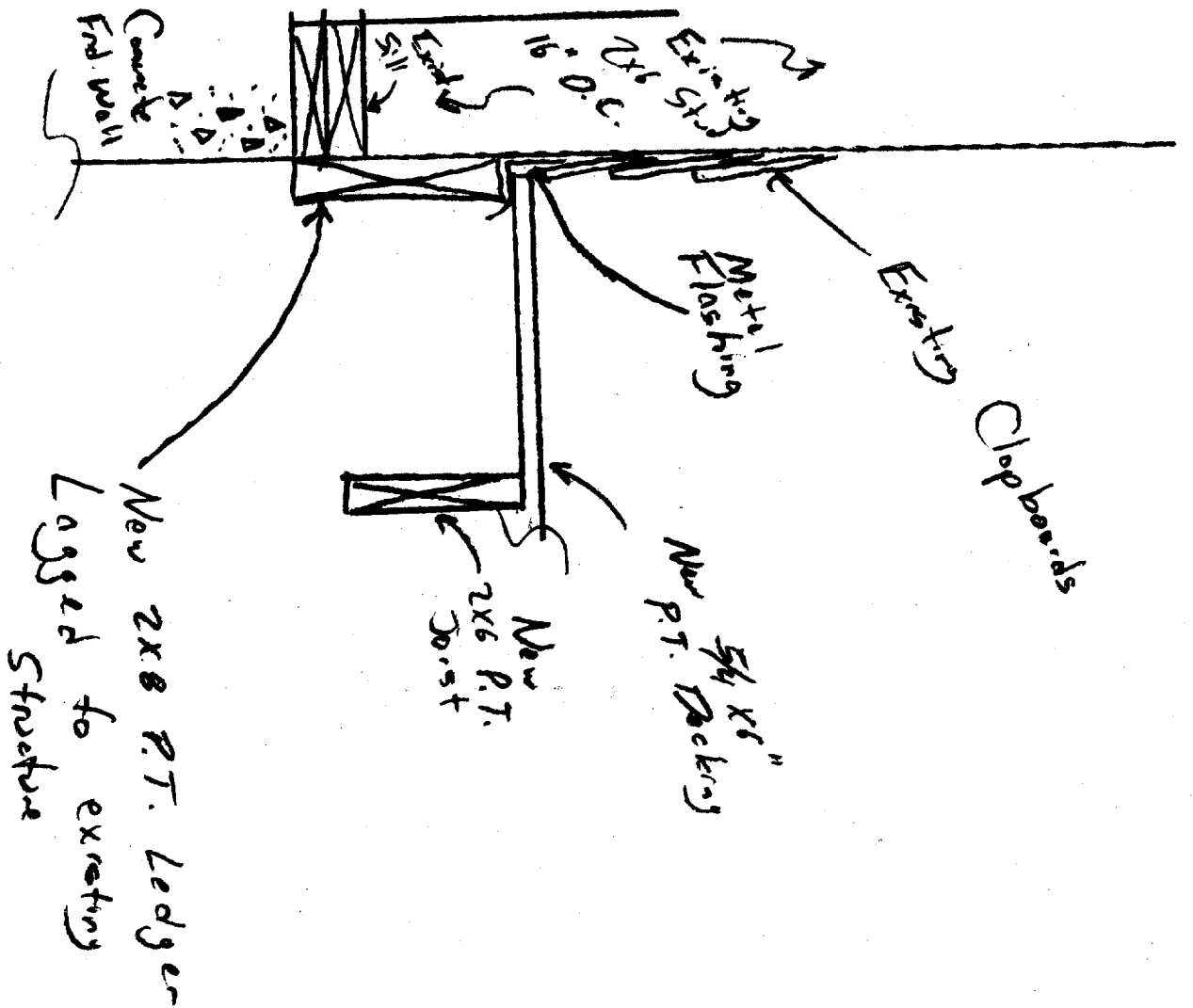

Attachment to Existing Structure Detail

Not to Scale

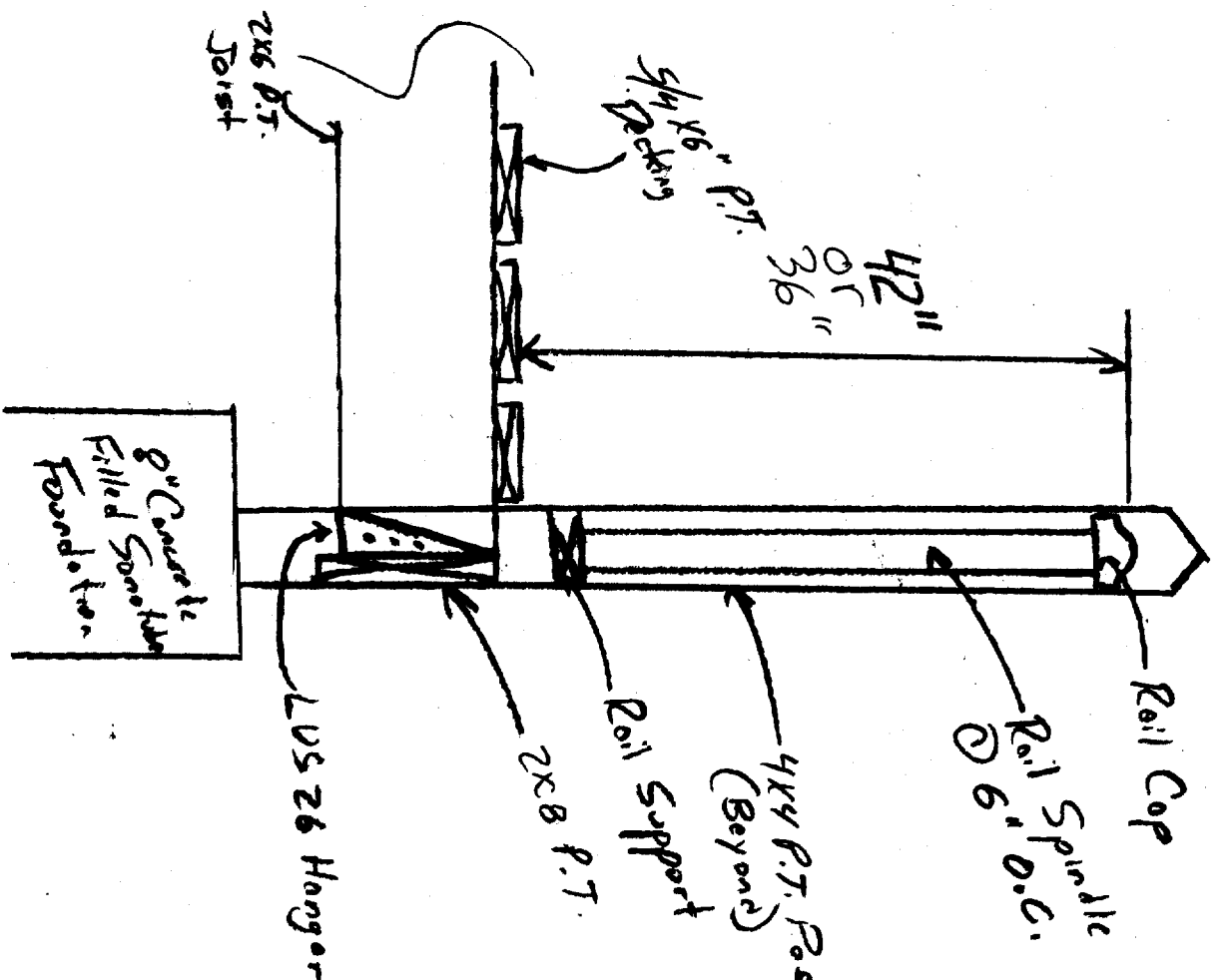

Railing Framing Detail

Not to Scale

DISPLAY THIS CARD ON PRINCIPAL FRONTAGE OF WORK
CITY OF PORTLAND

Please Read
Application And
Notes, If Any,
Attached

BUILDING INSPECTION

PERMIT ISSUED

Permit Number: 030617

JUN 05 2003

PERMIT

This is to certify that Rossi Louis J Sr &/Darren C ford

has permission to Build 15x20 deck in the rear

CITY OF PORTLAND

AT 50 Deering Run Dr

353 E004001

provided that the person or persons, firm or corporation accepting this permit shall comply with all of the provisions of the Statutes of Maine and of the ordinances of the City of Portland regulating the construction, maintenance and use of buildings and structures, and of the application on file in this department.

Apply to Public Works for street line and grade if nature of work requires such information.

Notification of inspection must be given and written permission procured before this building or part thereof is entered or closed-in. **HEAVY NOTICE IS REQUIRED.**

A certificate of occupancy must be procured by owner before this building or part thereof is occupied.

OTHER REQUIRED APPROVALS

- Fire Dept. _____
- Health Dept. _____
- Appeal Board _____
- Other _____
Department Name

Jamie Bonke 6/5/03
Director - Building & Inspection Services

PENALTY FOR REMOVING THIS CARD

BUILDING PERMIT INSPECTION PROCEDURES

Please call 874-8703 or ~~874-8693~~ to schedule your inspections as agreed upon

Permits expire in 6 months, if the project is not started or ceases for 6 months.

The Owner or their designee is required to notify the inspections office for the following inspections and provide adequate notice. Notice must be called in 48-72 hours in advance in order to schedule an inspection:

By initializing at each inspection time, you are agreeing that you understand the inspection procedure and additional fees from a "Stop Work Order" and "Stop Work Order Release" will be incurred if the procedure is not followed as stated below.

JB ~~Pre-construction Meeting~~: Must be scheduled with your inspection team upon receipt of this permit. Jay Reynolds, Development Review Coordinator at ~~874-8632~~ must also be contacted at this time, before any site work begins on any project other than single family additions or alterations.

- Footing/Building Location Inspection: Prior to pouring concrete
- NA Re-Bar Schedule Inspection: Prior to pouring concrete
- NA Foundation Inspection: Prior to placing ANY backfill
- NA Framing/Rough Plumbing/Electrical: Prior to any insulating or drywalling
- Final Certificate of Occupancy: Prior to any occupancy of the structure or use. NOTE: There is a ~~\$75.00~~ fee per inspection at this point.

Certificate of Occupancy is not required for certain projects. Your inspector can advise you if your project requires a Certificate of Occupancy. All projects DO require a final inspection

If any of the inspections do not occur, the project cannot go on to the next phase, REGARDLESS OF THE NOTICE OR CIRCUMSTANCES.

NA **CERTIFICATE OF OCCUPANCIES MUST BE ISSUED AND PAID FOR, BEFORE THE SPACE MAY BE OCCUPIED**

Signature of applicant/designee

Date

Signature of Inspections Official

Date

CBL: 353-E 4 Building Permit #: 03-0617

Building Sketch

Borrower/Client Louis J. Rossi, Sr			
Property Address 50 Deering Run Drive			
City Portland	County Cumberland	State ME	Zip Code 04103
Lender Gorham Savings Bank			

RZ Rear 25' Req 50' shown
 Side 12' Req 30' & 30' shown

