



Pool Installation/Construction Permit Application

If you or the property owner owes real estate or personal property taxes or user charges on any property within the City, payment arrangements must be made before permits of any kind are accepted.

Location/Address of Construction: <u>4 Allison Avenue</u>		
Total Square Footage of Proposed Structure <u>512 Pool 120 Shed</u>		Square Footage of Lot <u>11,378</u>
Tax Assessor's Chart, Block & Lot Chart# Block# Lot# <u>353 B1</u>	Owner: <u>Ronald and Jennifer Diome</u>	Telephone: <u>671-4281</u>
Lessee/Buyer's Name (If Applicable) <u>N/A</u>	Applicant name, address & telephone: <u>4 Allison Ave. Portland, ME 04103</u>	Cost Of Work: \$ <u>30,000</u> Fee: \$ <u>291.00</u>
Dimensions of pool: <u>16x32</u> above or below ground: <u>Below</u>		
Dimensions of decking and/or any platforms, sheds, or other structures: <u>Shed 10x12 on concrete Slab</u>		
Contractor's name, address & telephone: <u>Michaels Pool n' Patio 2010 Lisbon Rd Lewiston, ME 04240 782-1514</u>		
Who should we contact when the permit is ready: <u>Jennifer Diome</u>		
Mailing address: <u>4 Allison Ave. Portland, ME 04103</u>		Phone: <u>671-4281</u>

Please submit all of the information outlined in the pool application checklist. Failure to do so could result in the automatic denial of your permit.

In order to be sure the City fully understands the full scope of the project, the Planning and Development Department may request additional information prior to the issuance of a permit. For further information visit us on-line at www.portlandmaine.gov, stop by the Building Inspections office, room 315 City Hall or call 874-8703.

I hereby certify that I am the Owner of record of the named property, or that the owner of record authorizes the proposed work and that I have been authorized by the owner to make this application as his/her authorized agent. I agree to conform to all applicable laws of this jurisdiction. In addition, if a permit for work described in this application is issued, I certify that the Code Official's authorized representative shall have the authority to enter all areas covered by this permit at any reasonable hour to enforce the provisions of the codes applicable to this permit.

Signature of applicant: <u>Jennifer Diome</u>	Date: <u>3/24/11</u>
---	----------------------

This is not a permit; you may not commence ANY work until the permit is issued.

Dionne Pool Installation/Construction Permit Application

**4 Allison Avenue
Portland, Maine 04103**

1. Plot Plan
2. Structural details, size and dimensions of Pool
3. Construction details for shed
4. Design of fencing, gates, latches, and audible alarms
5. Proof of Ownership

PLOT PLAN

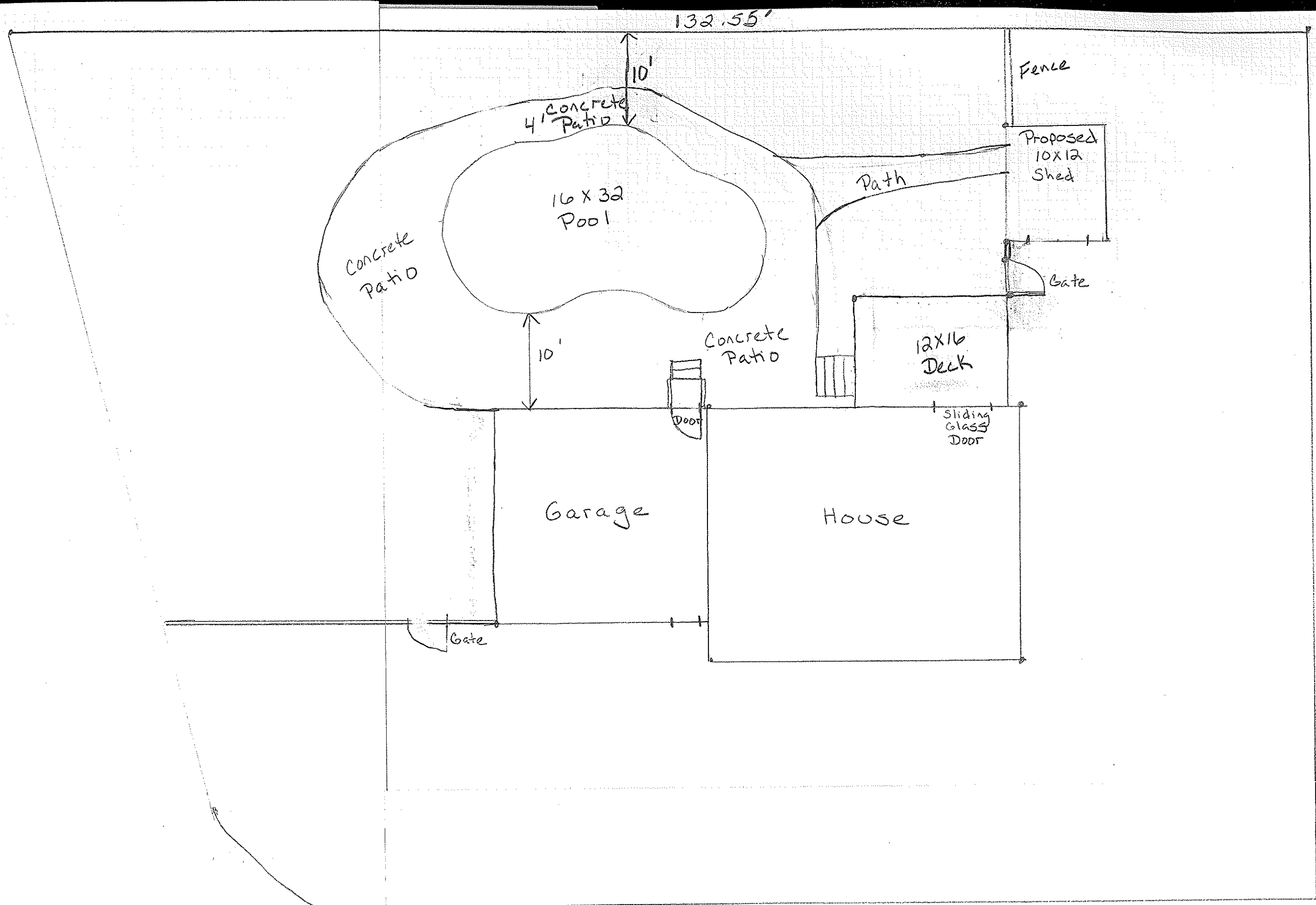

105.74'

1" = 10'

STRUCTURAL DETAILS, SIZE AND DIMENSIONS OF POOL



MICHAEL'S POOL 'N' PATIO, INC.

2010 LISBON ROAD
LEWISTON, MAINE 04240-1307
1 800-564-POOL

Excavation & backfilling for pool
14 gauge steel walls
Deluxe liner
Filter system with pump & motor
Skimmer (extra wide mouth)
2 returns with directional jets
Deluxe 3 step ladder
2 Handrails for stairs if stairs are purchased
Automatic chlorinator with closed atmosphere
Vacuum kit
Test kit
Complete plumbing - Flex pipe, fittings & valves
Starter chemical kit
concrete collar footing
Lifeline with floats

Extra costs if needed:
Building permit - Water to fill pool - Electrician
Removing ledge - sand fill - removing excess fill
Underground water - Loam & seed

2008

Part number	Description	Qty
02-CP06A-08	8R-6"	3
02-CI06A-08	8R-6" Inlet	1
02-CP03A-08	8R-3"	1
02-CP06A-07	7R-6"	1
02-CP04A-07	7R-4"	1
02-CP06A-06M	6"R-6"	2
02-CI06A-06M	6"R-6" Inlet	1
02-CP05A-06M	6"R-5"	1
02-CP04A-06M	6"R-4"	1
02-RP05A-07	C-5"	1
02-RP03A-08	D-3"	1
02-RP01T-08	D-19"	1
02-RP06A-09	E-6"	1
02-RP04A-09	E-4"	1
02-CK03A-00	6" Curve Skimmer	1
	6" Curve Step	-
	8" Kaffio Curve Step	-
A-Frame	A-Frame Multiplier	17
15-0632-9	Optional Deck Supports	22

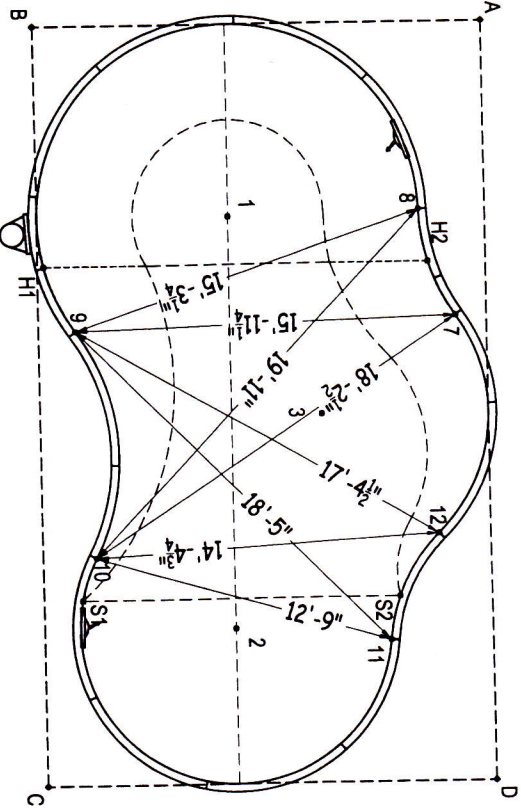
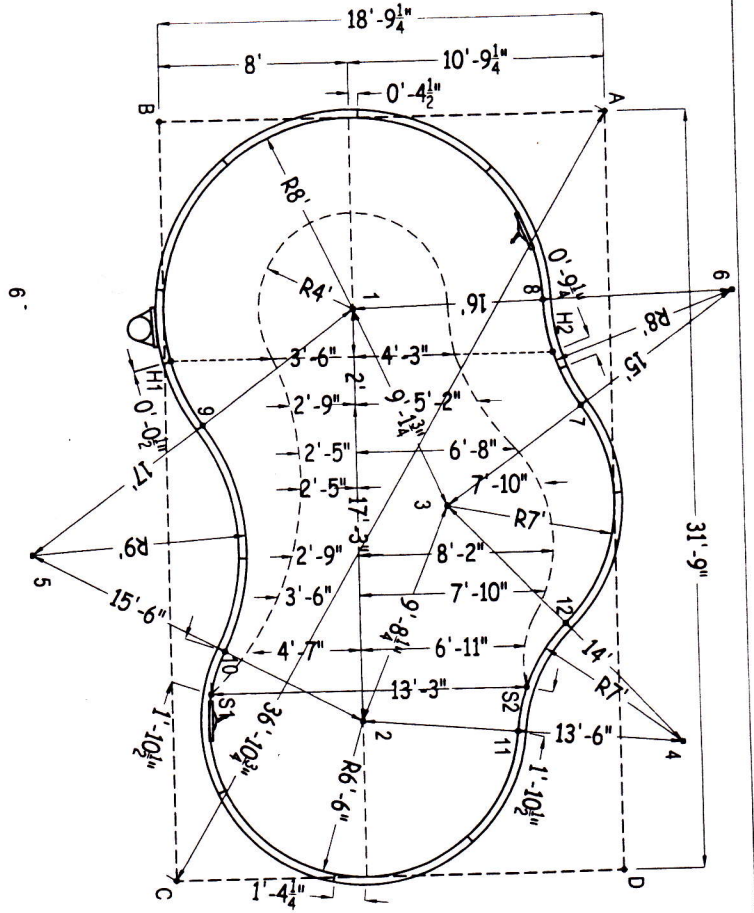

	A	B	C	D
1	13'-5"	11'-3 3/4"	25'-0 3/4"	26'-1"
2	27'-5 1/2"	26'-5 3/4"	10'-3 3/4"	12'-7"
3	17'-9 1/4"	20'-1 1/2"	19'-4 3/4"	16'-11 1/4"
4	26'-7"	34'-0 3/4"	22'-1"	5'-11 1/4"
5	30'-5"	18'-11"	14'-10 1/4"	28'-1"
6	9'-3"	25'-2 1/4"	34'-0 1/4"	24'-8 1/4"
7	12'-4"	21'-4 1/4"	26'-2"	19'-6 1/4"
8	8'-3 1/2"	17'-9 3/4"	28'-9 1/2"	24'-1 1/4"
9	21'-5"	12'-9 3/4"	19'-1"	25'-8"
10	27'-8 1/2"	22'-4"	9'-9 1/2"	19'-1"
11	26'-2 1/4"	29'-7 1/4"	15'-7 3/4"	7'-3 3/4"
12	21'-5"	27'-1"	19'-7"	10'-7"
H1	21'-0 1/2"	10"	21'-9"	28'-6 3/4"
H2	10'-3 1/2"	19'-2"	27'-2 1/2"	21'-10 1/2"
S1	29'-6"	24'-0 3/4"	7'-11"	18'-10"
S2	24'-3 3/4"	28'-3"	16'-9 1/2"	8'-8"
A		18'-9 1/4"	36'-10 3/4"	31'-9"

Tahiti 16' x 32' Left

DWG #: KAMLS42-1632-8H_08L

DATE: 01/Jan/2008

SHEET: 2 OF 2

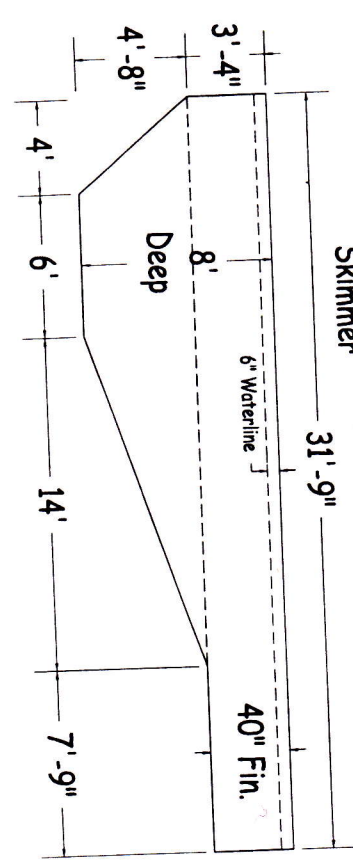
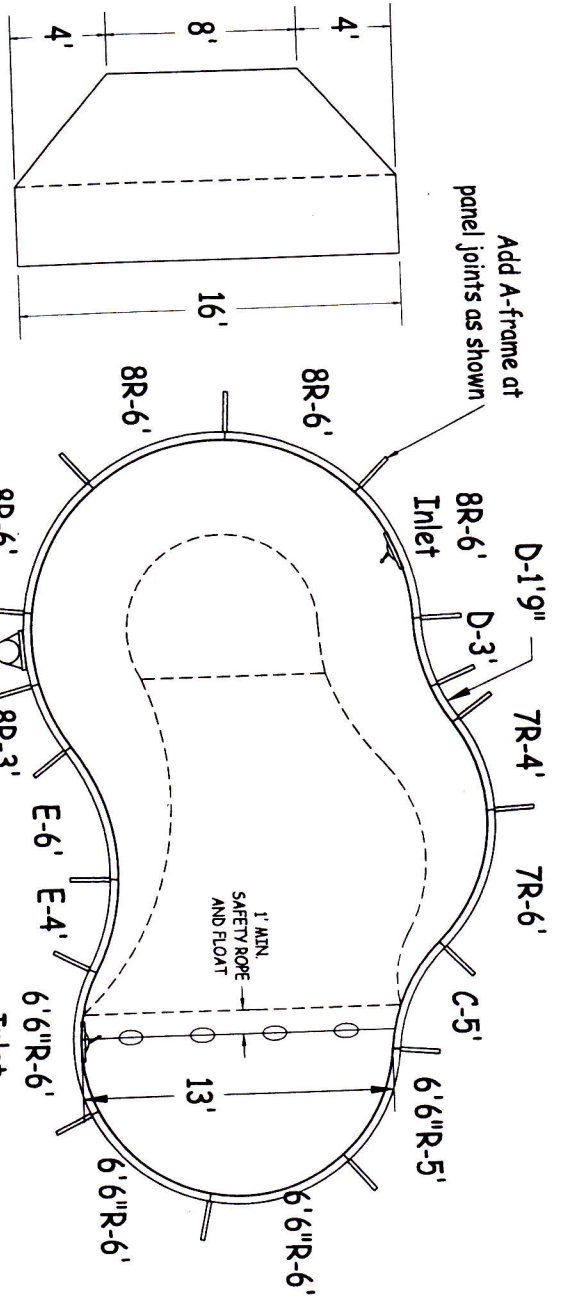

V A E V N
POOL PROGRAM

Tahiti 16' x 32' Left

DWG #: **KAMLS42-1632-8H 08L**

AREA (SqFt): 428 PERIMETER: 82'-10"

VOLUME (US Gal): 15 800

LINEAR AREA (SqFt): 508 DATE: 01/Jan/2008

VOLUME (Litres): 59 800

SAFETY COVER (SqFt): 757 SCALE: 1/8" = 1'

STEEL



Feet First

MEETS DEPTH AND SHAPE MINIMUM STANDARD ANS/SP15-2003

DIVING/SLIDING EQUIPMENT SHALL BE DESIGNED FOR SWIMMING POOLS AND SHALL BE INSTALLED IN ACCORDANCE WITH THE DIVING/SLIDING EQUIPMENT MANUFACTURER'S SPECIFICATIONS. PLEASE CONTACT THE DIVING/SLIDING EQUIPMENT MANUFACTURER FOR THEIR SPECIFICATIONS.

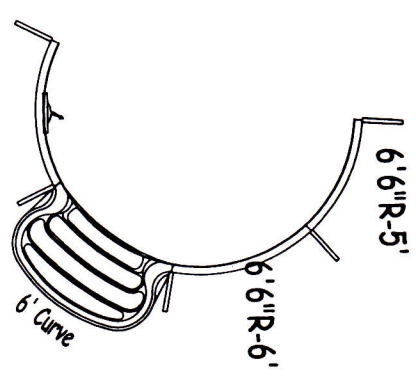

6' Step Option

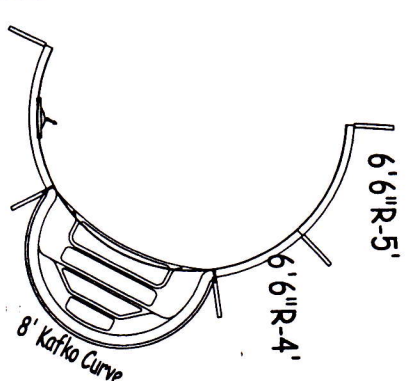

8' Step Option

SHEET: 1 OF 2

CONSTRUCTION DETAILS FOR SHED

- [Home](#)
- [FAQ's](#)
- [Directions](#)
- [Catalog Page](#)
- [Delivery](#)
- [Site Preparation](#)

Site Search:

Home



We are a Family Owned & Operated, Wood Furniture manufacturing and distribution company. With careful attention paid to both quality workmanship and quality customer service, we are here to provide the products you need to make your home and yard the wonderland you would like it to be.

With over 100 years experience in two generations, we know how to do it right. From selecting and cutting the trees, to the finished product, we do it all.

If you have any questions feel free to call Richard anytime, 207-786-3304

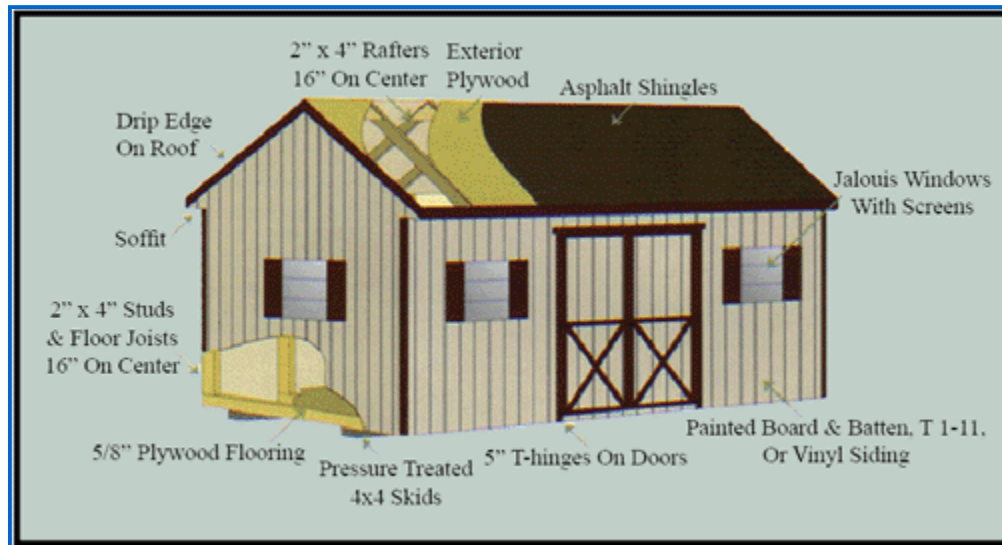

*These buildings are strong enough to accommodate the heavier lawn and garden tractors. They will withstand severe wind and snow. The pressure treated skids will not rot and facilitate moving the shed if necessary. *

DESIGN OF FENCING, GATES, LATCHES AND AUDIBLE ALARMS

Details of Barrier Protection

Existing fence that runs along Deering Run and along the property line abutting Map 353/Lot B2 is 68" high at the lowest point (photo below). The current clearance between grade and existing fence ranges from <1" to 6". This will be modified to be 2" or less.



Existing fence along Alison Avenue from the existing garage to Deering Run property line (photo below) will be modified to meet 48" requirements and include a self-locking gate (latch and hinge specifications attached) that opens to the street or replaced with 48" fence identified on attached.



Fence will be closed off from the open end of the existing fence to the existing deck with proposed shed and fence identified on attached with a self-locking gate (latch and hinge specifications attached) that opens away from the pool area.

Door alarms will be installed on the door entering the pool area from the existing garage as well as the sliding glass door entering onto the existing deck. Specifications of the door alarm are attached.

Vinyl Fences Inc

[HOME](#) [ABOUT US](#) [CONTACT US](#) [FENCE SHOWROOM](#) [REGIS ALUMINUM SHOWROOM](#) [ACCESSORY SHOWROOM](#) [CUSTOM DESIGNS](#)

[RAILING](#) [MISC](#)



1-10 of 10 [Previous](#) | [Next](#)

Castle is an Open Top Semi Privacy style panel. Pickets are 7/8" x 3" with 3/4" spacing. Top and bottom rails are 1 1/2" x 5 1/2", mid rail (5' and 6' high) is 2" x 3 1/2". Standard heights are 48", 60" 72". Custom sizes available. Includes bottom aluminum channel. Colors: White and Tan (additional 10%).



FenceMax.com
Gate Hardware Professionals
since 1969
888-867-1139
toll free in U.S. & Canada

Home Products Help/FAQ Return Policy Contact Us Basket **Checkout**

Advanced Search



TESTED DAILY 21-MAR

Same Day Shipping
on most items [click for details](#)

Tax Free Shopping !!
(& no sneaky handling charges)

[Sign In / Create Account](#)
[Wholesale Pricing Information](#)

Basket Contents

Quantity in Basket: none

[Recently Visited Items](#)



- [Gate Latch](#)
[Magna Latch](#)
[Magna Latch Top Pull](#)
[Magna Latch Vertical Pull](#)
[Magna Latch Side Pull](#)
[Magna Latch Glass Gate](#)
[Repair Parts](#)
[Accessories](#)
[Lokk Latch](#)
[Toggle Latch](#)
[Z-Lokk](#)
[Auto Latch](#)
[Strong Arm Latch](#)
[Sentry Latch](#)
[Stainless Steel Gate Latches](#)
[Steel Gate Latches](#)
[Gate Hinge](#)
[Drop Rods](#)
[Accessories](#)
[Specials](#)
[High Security Locks](#)
[Fasteners](#)
[Other Fence Hardware](#)
[Search By Color](#)
[Search By Mfr Code](#)
[Help/FAQ](#)

[Home](#) > [Gate Latch](#) > [Magna Latch](#) > New Series 2 Magna Latch Vertical Pull - White

New Series 2 Magna Latch Vertical Pull - White

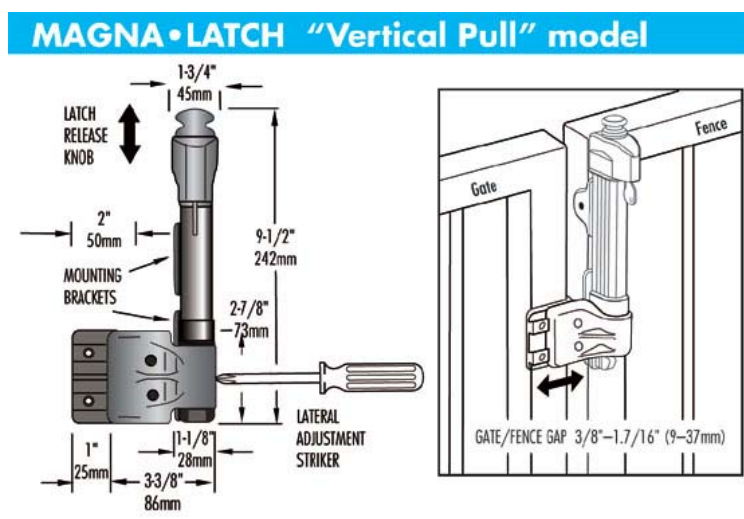

Quantity in Basket: *None*
 Code: **VGHDD1020WT**
 Price: **\$65.95**
 Shipping Weight: 1.13 pounds
 Color: **Wht**
 Mfr#: **MLVPS2WTBGA**
 52 available for immediate delivery

Other Information (opens in new window):
[Installation Instructions .PDF / 765K](#)
[Magna Latch Vertical Pull Video](#)
[3D Animation .MOV / 6.4MB](#)
[Pool Safety Video .MOV / 16MB](#)
[Quality Assurance Video .MOV / 12.6MB](#)
[Frequently Asked Questions](#)

You will need these free programs to view the above files.



LIVE HELP

Offline now
Leave us a message.

Quantity:

The Magna-Latch Vertical Pull is a magnetic lockable gate latch, that when used with Tru Close Hinges, meets or exceeds the most stringent of pool codes (BOCA). Comes with screws and easy to follow instructions. Lifetime Warranty!! This is the little brother to the Magna Latch Top Pull. Works with vinyl, wood and metal (square frame) gates. Can also be on chain link (round frame) gates when used in conjunction with the round post adaptor (CGHDD1026). Lifetime Warranty!! . Note - Works on a left or right swinging gate. asseenontv





MEMBER
NADPA
National Drowning Prevention Alliance

NOW ACCEPTING
PayPal

Customers who purchased this product, also purchased:

Code	Name	Price
MGHDD1005WT	3 inch Tru Close Self Closing Hinge 2 legs - White (pair)	\$29.99 <input type="button" value="Add One to Basket"/>
VGHDD1039WT	5-1/2 inch Tru Close Self Closing Hinge 2 leg - White (pair)	\$32.95 <input type="button" value="Add One to Basket"/>
VGHDD1038WT	5-1/2 inch Tru Close Self Closing Hinge no leg - White (pair)	\$32.95 <input type="button" value="Add One to Basket"/>
MGHDD1003WT	3 inch Tru Close Self Closing Hinge no legs - White (pair)	\$29.99 <input type="button" value="Add One to Basket"/>
MGHDD1010WT	Mini Multi Tru Close Self Closing Hinge - White (pair)	\$54.95 <input type="button" value="Add One to Basket"/>

[Home](#)
[Basket](#)
Magna Latch
[Account](#)
[Checkout](#)
Lokk Latch
[Products](#)
[Return Policy](#)
Z-Lokk
[Help/FAQ](#)
[Contact Us](#)
Tru Close

[Visit Our Blog on Gate Hardware](#) | [Follow FenceMax on Twitter](#) | [Connect with FenceMax on FaceBook](#)



FenceMax.com
Gate Hardware Professionals
since 1969
888-867-1139
toll free in U.S. & Canada

Home Products Help/FAQ Return Policy Contact Us Basket **Checkout**

Advanced Search

 TESTED DAILY 21-MAR

Tightens to 75 psi !!  **FLEXI-CLAMP™**

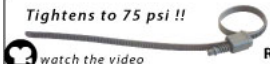
watch the video  Rust-Free • Re-usable • Non-conductive





Tax Free Shopping !!
(& no sneaky handling charges)

[Sign In / Create Account](#)
[Wholesale Pricing Information](#)

Basket Contents

Quantity in Basket: none

[Recently Visited Items](#)

[Gate Latch](#)
[Gate Hinge](#)
[Drop Rods](#)
[Accessories](#)
[Specials](#)
[High Security Locks](#)
[Fasteners](#)
[Other Fence Hardware](#)
[Search By Color](#)
[Search By Mfr Code](#)
[Help/FAQ](#)

LIVE HELP

Offline now
Leave us a message.



Send

[Home](#) > [Gate Hinge](#) > [Tru Close Hinge](#) > [Regular Duty](#) > 3 inch Tru Close Self Closing Hinge 2 legs - Black (pair)

3 inch Tru Close Self Closing Hinge 2 legs - Black (pair)

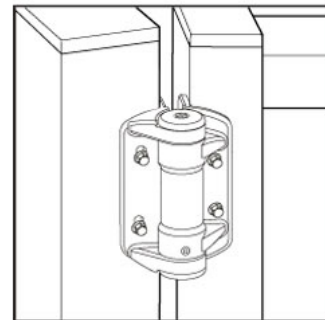
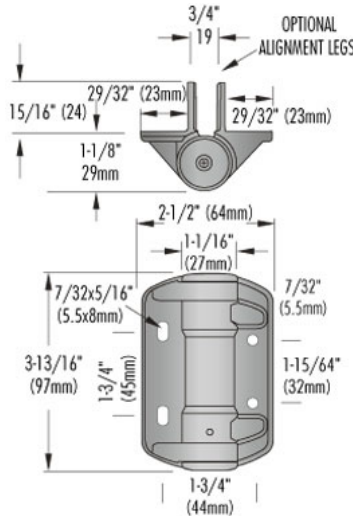

Quantity in Basket: *None*
Code: **MGHDD1005**

Price: **\$29.99**

Shipping Weight: **0.54** pounds

Color: **Blk**

Mfr#: **TCA1L2-Mk2**

Sorry, we are currently sold out of '3 inch Tru Close Self Closing Hinge 2 legs - Black (pair)' (MGHDD1005). Please check back later.

Other Information (opens in new window):

[Installation Instructions](#) .PDF / 270K

[Product Video](#) .MOV / 14.9MB

[3D Animation](#) .MOV / 4.3MB

[Pool Safety Video](#) .MOV / 16MB

[Quality Assurance](#)

[Video](#) .MOV / 12.6MB

[Frequently Asked Questions](#)

You will need these free programs to view the above files.



Need Fasteners?: None
 16 - Black Stainless Steel Self Drilling Screws for Metal or Vinyl ... add \$4.00

Quantity:

For regular range square frame gates weighing up to 55 lbs. Works best with ornamental aluminum or steel gate and fence materials. The 2 alignment legs help keep the hinges square to your gate and hinge post while at the same time adding additional strength by accepting extra screws. TRU CLOSE safety gate hinges are molded from special glass-fiber reinforced polymer materials. These UV-stabilized materials provide strong, rust-free hinges that won't bind, sag or stain! And they never require lubrication. The unique, spring-loaded adjustor within most TRU CLOSE hinges allows instant incremental tension adjustment using only a screwdriver. Quick, easy and safe! Please scroll down or select from the additional product pages below for more color and size options. Fasteners sold separately. asseenontv truclose

Customers who purchased this product, also purchased:

Code	Name	Price
VGHDD1025	New Series 2 Magna Latch Top Pull - Black	\$65.99 <input type="button" value="Add One to Basket"/>
VGHDD1020	New Series 2 Magna Latch Vertical Pull - Black	\$62.95 <input type="button" value="Add One to Basket"/>
MGHDD1019	Residential Lokk Latch Series 2 no button - Black	\$25.95 <input type="button" value="Add One to Basket"/>
VGHDD1010	New Series 2 Magna Latch Side Pull - Black	\$23.95 <input type="button" value="Add One to Basket"/>





MEMBER **N-DPA**
National Drowning Prevention Alliance

NOW ACCEPTING
PayPal™

Find

POOLGUARD WIRELESS DOOR ALARM: MODEL DAPT-WT

Find a Dealer

- > Home
- > Pool Fences
- > Pool Nets
- > Pool Covers
- >> Pool Alarms
 - > Pool Alarms
 - >> **Door & Gate Alarms**
 - > Child Safety Alarms
 - > View All Alarms
 - > Help Center
- > Pet Safety
- > Pool Supplies
- > Pool Safety Resources



Model number: **ALARM-DAPTWT**

- Alarm sounds immediately when door opens.
- Outdoor wireless transmitter pass-thru feature.
- UL Listed / UL 2017.
- Easy installation.
- One-year manufacturer warranty.

Price: \$68.99

zoom



> **ESTIMATED DELIVERY TIME**
Usually ships within 24 hours.

Description Features More Information

- The **Door Alarm** will sound immediately when a child opens the door, and will continue to sound if the door is left open. If a child goes through the door and closes it, the alarm will sound for five minutes and then automatically reset.
- **Poolguard Door Alarm** Model DAPT-WT is equipped with an Outdoor Wireless Transmitter that allows adults to enter the home from the outside without the alarm sounding, and is easy to install.
- The **Door Alarm** is always on and will automatically reset under all conditions.
- **Poolguard Door Alarm** is equipped with an adult pass through feature that will allow adults to go through the door without the alarm sounding.
- Optional screen door kits can be purchased for the alarm, this kit allows you to get air through your screen door without the alarm sounding.
- **Poolguard Door Alarm** uses one 9-volt battery (not included).
- The **Door Alarm** is equipped with a low battery indicator that will audibly alert you when your battery is getting low.
- The **Poolguard Door Alarm** is UL listed under UL 2017 for water hazard entrance alarm equipment.

"What a fantastic hard working crew and great customer service. The Safety Net looks so good! My wife and I could not be happier!"
-Steven,
Moreno Valley, CA

RELATED ITEMS



Poolguard Screen Door Kit



Poolguard Door Alarm: Model DAPT-2

PROOF OF OWNERSHIP

Assessor's Office | 389 Congress Street | Portland, Maine 04101 | Room 115 | (207) 874-8486

City Home Departments City Council E-Services Calendar Jobs

This page contains a detailed description of the Parcel ID you selected. Press the **New Search** button at the bottom of the screen to submit a new query.

Current Owner Information:

Services

Applications

Doing Business

Maps

Tax Relief

Tax Roll

Q & A

browse city services a-z

browse facts and links a-z

CBL 353 B001001
Land Use Type SINGLE FAMILY
Property Location 4 ALLISON AVE
Owner Information DIONNE JENNIFER S & RONALD A DIONNE JTS
 4 ALLISON AVE
 PORTLAND ME 04103
Book and Page 26933/186
Legal Description 353-B-1
 DEERING RUN DR 27-33
 ALLISON AVE 4-10
 11378 SF
Acres 0.261

Current Assessed Valuation:

TAX ACCT NO. 37804 **OWNER OF RECORD AS OF APRIL 2010**
 DIONNE JENNIFER S &
 RONALD A DIONNE JTS
 4 ALLISON AVE
 PORTLAND ME 04103
LAND VALUE \$72,700.00
BUILDING VALUE \$189,000.00
NET TAXABLE - REAL ESTATE \$261,700.00
TAX AMOUNT \$4,689.66

Any information concerning tax payments should be directed to the Treasury office at 874-8490 or [e-mailed](#).

Building Information:

Card 1 of 1
Year Built 1993
Style/Structure Type COLONIAL
Stories 2
Bedrooms 3
Full Baths 2
Half Baths 2
Total Rooms 9
Attic NONE
Basement FULL
Square Feet 1664

[View Sketch](#) [View Map](#) [View Picture](#)



Sales Information:

Sale Date	Type	Price	Book/Page
5/28/2009	LAND + BUILDING	\$307,000.00	26933/186
6/1/2003	LAND + BUILDING	\$292,000.00	19569/194
2/15/1996	LAND + BUILDING	\$158,000.00	12352/174
5/10/1993	LAND + BUILDING	\$40,000.00	10680/138

New Search!



Best viewed at 800x600, with Internet Explorer