

DISPLAY THIS CARD ON PRINCIPAL FRONTAGE OF WORK



CITY OF PORTLAND

BUILDING PERMIT

This is to certify that JENNIFER S& DIONNE

Located At 4 ALLISON AVE

Job ID: 2011-03-667-POOL

CBL: 353 - - B - 001 - 001 - - - -

has permission to install a 16' x 32' inground Pool & 10' x 12' Shed
provided that the person or persons, firm or corporation accepting this permit shall comply with all of the provisions of the Statutes of Maine and of the Ordinances of the City of Portland regulating the construction, maintenance and use of the buildings and structures, and of the application on file in the department.

Notification of inspection and written permission procured before this building or part thereof is lathed or otherwise closed-in. 48 HOUR NOTICE IS REQUIRED.

A final inspection must be completed by owner before this building or part thereof is occupied. If a certificate of occupancy is required, it must be

04/19/2011

Fire Prevention Officer

Code Enforcement Officer / Plan Reviewer

**THIS CARD MUST BE POSTED ON THE STREET SIDE OF THE PROPERTY.
PENALTY FOR REMOVING THIS CAR**

SCANNED

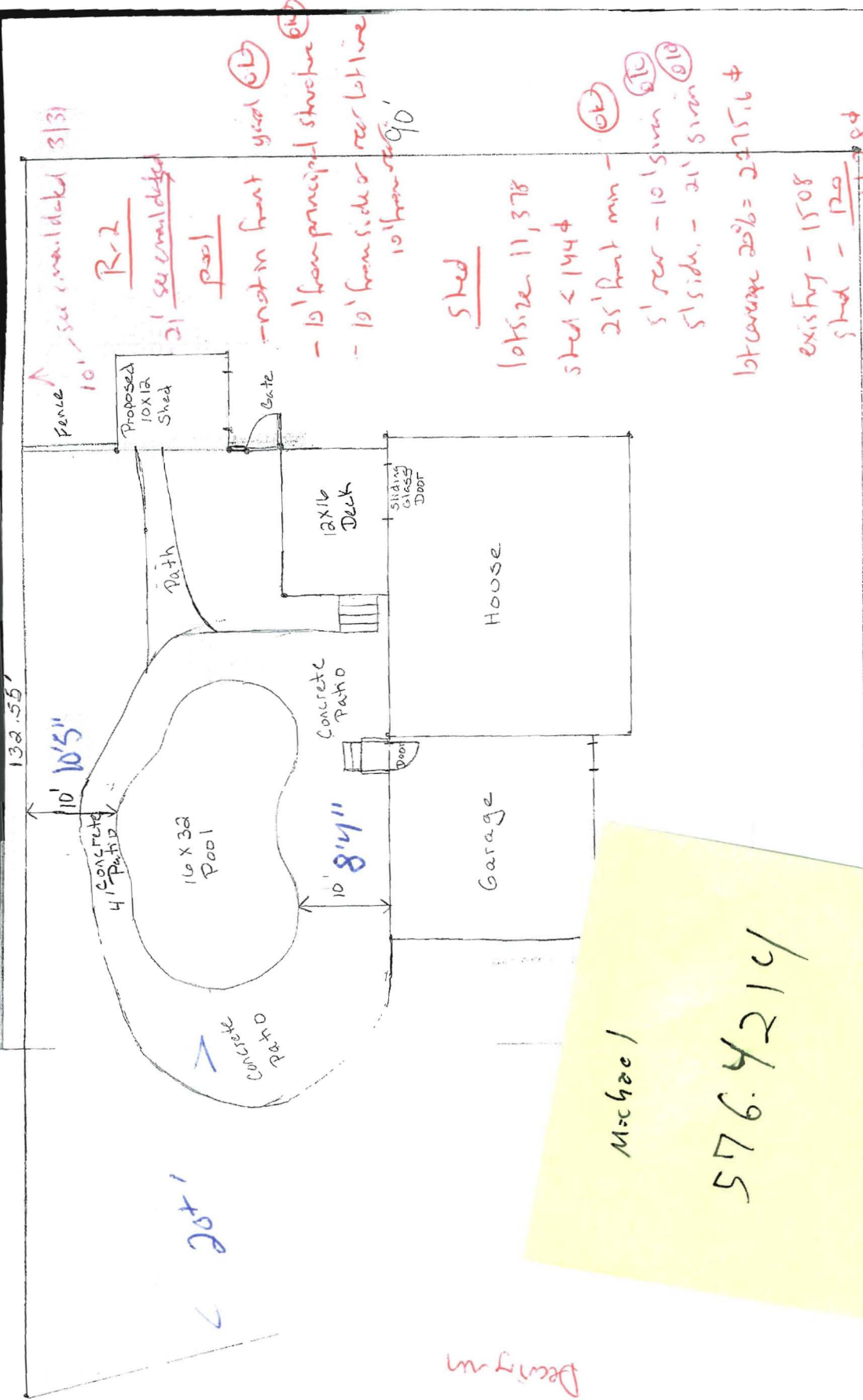

Michael
 576.4214

Deerlyn

Allison

City of Portland, Maine - Building or Use Permit Application

389 Congress Street, 04101 Tel: (207) 874-8703, FAX: (207) 8716

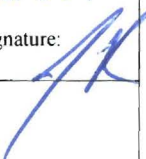
Job No: 2011-03-667-POOL	Date Applied: 3/24/2011	CBL: 353 - - B - 001 - 001 - - - - -	
Location of Construction: 4 ALLISON AVE	Owner Name: JENNIFER & RONALD DIONNE	Owner Address: 4 ALLISON AVE PORTLAND, ME 04103	Phone: 671-4281
Business Name:	Contractor Name: Michael's Pool n' Patio	Contractor Address: 2010 Lisbon RD LEWISTON ME 04240	Phone: (207) 782-1514
Lessee/Buyer's Name:	Phone:	Permit Type: POOL IN - Pool - In Ground	Zone: R-2
Past Use: Single Family	Proposed Use: Single Family - install in ground pool (16' x 32') & 10' x 12' shed	Cost of Work: 30000.00	CEO District:
		Fire Dept: <input type="checkbox"/> Approved <input type="checkbox"/> Denied <input checked="" type="checkbox"/> N/A	Inspection: Use Group: Type: Pool Sec. 6-24 Signature: 
Proposed Project Description: 4 Allison Ave. - in ground pool & shed		Pedestrian Activities District (P.A.D.)	
Permit Taken By:	Zoning Approval		

	Special Zone or Reviews	Zoning Appeal	Historic Preservation
1. This permit application does not preclude the Applicant(s) from meeting applicable State and Federal Rules. 2. Building Permits do not include plumbing, septic or electrical work. 3. Building permits are void if work is not started within six (6) months of the date of issuance. False informatin may invalidate a building permit and stop all work.	<input type="checkbox"/> Shoreland <input type="checkbox"/> Wetlands <input type="checkbox"/> Flood Zone <input type="checkbox"/> Subdivision <input type="checkbox"/> Site Plan <input type="checkbox"/> Maj <input type="checkbox"/> Min <input type="checkbox"/> MM	<input type="checkbox"/> Variance <input type="checkbox"/> Miscellaneous <input type="checkbox"/> Conditional Use <input type="checkbox"/> Interpretation <input type="checkbox"/> Approved <input type="checkbox"/> Denied	<input checked="" type="checkbox"/> Not in Dist or Landmark <input type="checkbox"/> Does not Require Review <input type="checkbox"/> Requires Review <input type="checkbox"/> Approved <input type="checkbox"/> Approved w/Conditions <input type="checkbox"/> Denied
	Date: DKW/cardi/hor 3/31/11 ABM	Date:	Date: ABM
	CERTIFICATION		

I hereby certify that I am the owner of record of the named property, or that the proposed work is authorized by the owner of record and that I have been authorized by the owner to make this application as his authorized agent and I agree to conform to all applicable laws of this jurisdiction. In addition, if a permit for work described in the application is issued, I certify that the code official's authorized representative shall have the authority to enter all areas covered by such permit at any reasonable hour to enforce the provision of the code(s) applicable to such permit.

SIGNATURE OF APPLICANT	ADDRESS	DATE	PHONE
RESPONSIBLE PERSON IN CHARGE OF WORK, TITLE		DATE	PHON

BUILDING PERMIT INSPECTION PROCEDURES

Please call 874-8703 or 874-8693 (ONLY)

or email: buildinginspections@portlandmaine.gov

With the issuance of this permit, the owner, builder or their designee is required to provide adequate notice to the city of Portland Inspections Services for the following inspections. Appointments must be requested 48 to 72 hours in advance of the required inspection. The inspection date will need to be confirmed by this office.

- **Please read the conditions of approval that is attached to this permit!! Contact this office if you have any questions.**
- **Permits expire in 6 months. If the project is not started or ceases for 6 months.**
- **If the inspection requirements are not followed as stated below additional fees may be incurred due to the issuance of a "Stop Work Order" and subsequent release to continue.**

1. Setbacks: *Shed and Pool Location*
2. Grounding Grid- Prior to Concrete Pour (*Electrical Requirements*)
3. Final Inspection (*Verify Pool Barrier Requirements*)

The project cannot move to the next phase prior to the required inspection and approval to continue, REGARDLESS OF THE NOTICE OF CIRCUMSTANCES.

IF THE PERMIT REQUIRES A CERTIFICATE OF OCCUPANCY, IT MUST BE PAID FOR AND ISSUED TO THE OWNER OR DESIGNEE BEFORE THE SPACE MAY BE OCCUPIED.



PORTLAND MAINE

Strengthening a Remarkable City, Building a Community for Life • www.portlandmaine.gov

Director of Planning and Urban Development
Penny St. Louis

Job ID: 2011-03-667-POOL

Located At: 4 ALLISON AVE.

CBI: 353 - - B - 001 - 001 - - - -

Conditions of Approval:

Zoning

1. This permit is being approved on the basis of plans submitted. Any deviations shall require a separate approval before starting that work.
2. This property shall remain a single family dwelling. Any change of use shall require a separate permit application for review and approval.
3. As discussed during the review process, the property must be clearly identified prior to pouring concrete and compliance with the required setbacks must be established. Due to the proximity of the setbacks of the pool (minimum of 10' from rear property line), it may be required to be located by a surveyor.

Building

1. Pool and barrier installation shall meet the code requirements in Sec. 6-24, *See Attached**.
2. Separate permits are required for any **electrical**, plumbing, sprinkler, fire alarm HVAC systems, heating appliances, including pellet/wood stoves, commercial hood exhaust systems and fuel tanks. Separate plans may need to be submitted for approval as a part of this process.

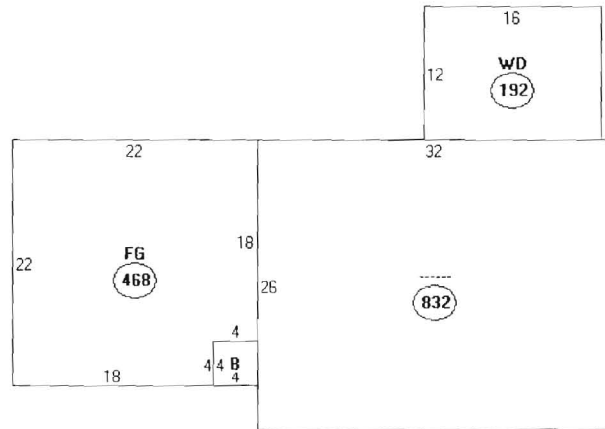

Descriptor/Area

- A -----
832 sqft
- B OFF
16 sqft
- C FG
468 sqft
- D wD
192 sqft



MICHAEL'S POOL 'N' PATIO, INC.

2010 LISBON ROAD
LEWISTON, MAINE 04240-1307
1 800-564-POOL

Excavation & backfilling for pool
14 gauge steel walls
Deluxe liner
Filter system with pump & motor
Skimmer (extra wide mouth)
2 returns with directional jets
Deluxe 3 step ladder
2 Handrails for stairs if stairs are purchased
Automatic chlorinator with closed atmosphere
Vacuum kit
Test kit
Complete plumbing - Flex pipe, fittings & valves
Starter chemical kit
concrete collar footing
Lifeline with floats

Extra costs if needed:

Building permit - Water to fill pool - Electrician
Removing ledge - sand fill - removing excess fill
Underground water - Loam & seed

Details of Barrier Protection

Existing fence that runs along Deering Run and along the property line abutting Map 353/Lot B2 is 68" high at the lowest point (photo below). The current clearance between grade and existing fence ranges from <1" to 6". This will be modified to be 2" or less.



Existing fence along Alison Avenue from the existing garage to Deering Run property line (photo below) will be modified to meet 48" requirements and include a self-locking gate (latch and hinge specifications attached) that opens to the street or replaced with 48" fence identified on attached.



Assessor's Office | 389 Congress Street | Portland, Maine 04101 | Room 115 | (207) 874-8486

[City](#) [Home](#) [Departments](#) [City Council](#) [E- Services](#) [Calendar](#) [Jobs](#)

This page contains a detailed description of the Parcel ID you selected. Press the **New Search** button at the bottom of the screen to submit a new query

Current Owner Information:

Services

- Applications
- Doing Business
- Maps
- Tax Relief
- Tax Roll
- Q & A

CBL	353 B001001
Land Use Type	SINGLE FAMILY
Property Location	4 ALLISON AVE
Owner Information	DIONNE JENNIFER S & RONALD A DIONNE JTS 4 ALLISON AVE PORTLAND ME 04103
Book and Page	26933/186
Legal Description	353-B-1 DEERING RUN DR 27-33 ALLISON AVE 4-10 11378 SF
Acres	0.261

Current Assessed Valuation:

TAX ACCT NO.	37804	OWNER OF RECORD AS OF APRIL 2010
LAND VALUE	\$72,700.00	DIONNE JENNIFER S & RONALD A DIONNE JTS
BUILDING VALUE	\$189,000.00	4 ALLISON AVE
NET TAXABLE - REAL ESTATE	\$261,700.00	PORTLAND ME 04103
TAX AMOUNT	\$4,689.66	

Any information concerning tax payments should be directed to the Treasury office at 874-8490 or [e-mailed](#).



Best viewed at 800x600, with Internet Explorer

Building Information:

Card 1 of 1

Year Built	1993
Style/Structure Type	COLONIAL
# Stories	2
Bedrooms	3
Full Baths	2
Half Baths	2
Total Rooms	9
Attic	NONE
Basement	FULL
Square Feet	1664

[View Sketch](#) [View Map](#) [View Picture](#)



Sales Information:

Sale Date	Type	Price	Book/Page
5/28/2009	LAND + BUILDING	\$307,000.00	26933/186
6/1/2003	LAND + BUILDING	\$292,000.00	19569/194
2/15/1996	LAND + BUILDING	\$158,000.00	12352/174
5/10/1993	LAND + BUILDING	\$40,000.00	10680/138

[New Search!](#)

Vinyl Fences Inc

[HOME](#) [ABOUT US](#) [CONTACT US](#) [FENCE SHOWROOM](#) [REGIS ALUMINUM SHOWROOM](#) [ACCESSORY SHOWROOM](#) [CUSTOM DESIGNS](#)

[RAILING](#) [MISC](#)

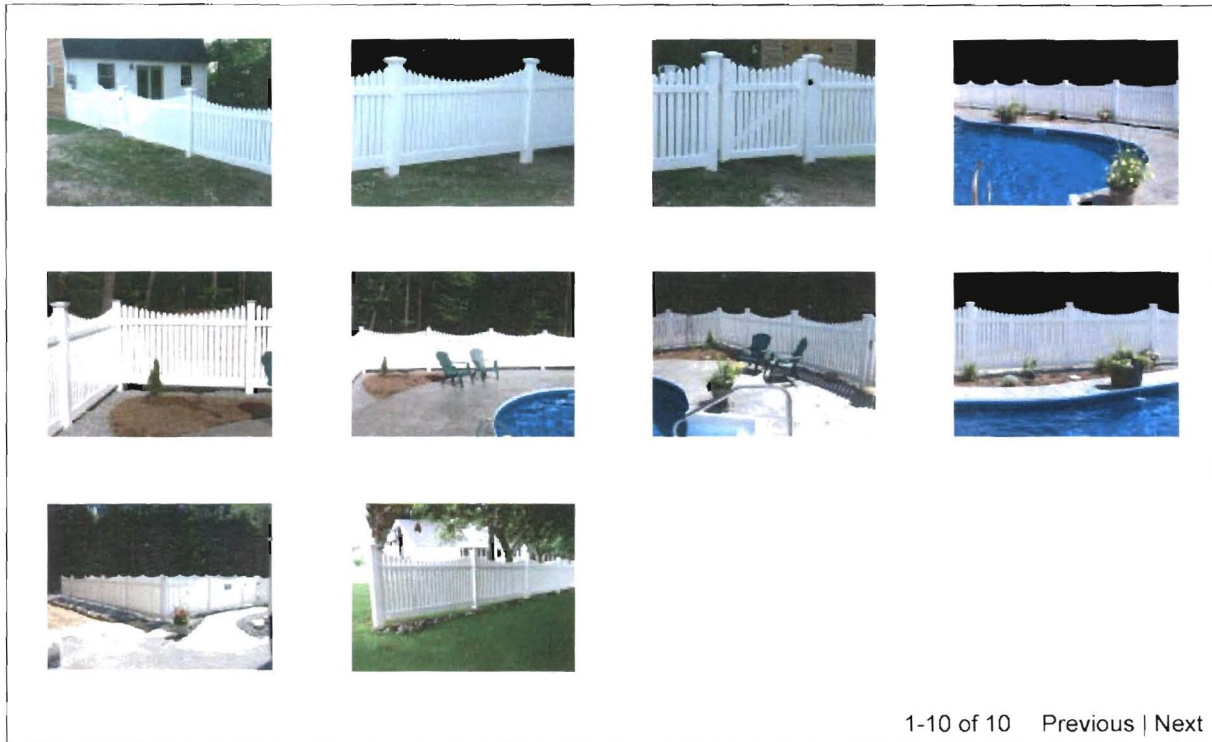

Castle is an Open Top Semi Privacy style panel. Pickets are 7/8" x 3" with 3/4" spacing. Top and bottom rails are 1 1/2" x 5 1/2", mid rail (5' and 6' high) is 2" x 3 1/2". Standard heights are 48", 60" 72". Custom sizes available. Includes bottom aluminum channel. Colors: White and Tan (additional 10%).

Fence will be closed off from the open end of the existing fence to the existing deck with proposed shed and fence identified on attached with a self-locking gate (latch and hinge specifications attached) that opens away from the pool area.

Door alarms will be installed on the door entering the pool area from the existing garage as well as the sliding glass door entering onto the existing deck. Specifications of the door alarm are attached.



FenceMax.com
Gate Hardware Professionals
Since 1969
888-867-1139
toll free in U.S. & Canada

Home Products Help/FAQ Return Policy Contact Us Basket **Checkout**

Advanced Search

 TESTED DAILY 21-MAR

Same Day Shipping
on most items [click for details](#)

Tax Free Shopping !!
(& no sneaky handling charges)

[Home](#) > [Gate Latch](#) > [Magna Latch](#) > New Series 2 Magna Latch Vertical Pull - White

[Sign In / Create Account](#)

New Series 2 Magna Latch Vertical Pull - White

[Wholesale Pricing Information](#)

Basket Contents

Quantity in Basket: none

[Recently Visited Items](#)



- [Gate Latch](#)
- [Magna Latch](#)
- [Magna Latch Top Pull](#)
- [Magna Latch Vertical Pull](#)
- [Magna Latch Side Pull](#)
- [Magna Latch Glass Gate](#)
- [Repair Parts](#)
- [Accessories](#)
- [Lokk Latch](#)
- [Toggle Latch](#)
- [Z-Lokk](#)
- [Auto Latch](#)
- [Strong Arm Latch](#)
- [Sentry Latch](#)
- [Stainless Steel Gate Latches](#)
- [Steel Gate Latches](#)
- [Gate Hinge](#)
- [Drop Rods](#)
- [Accessories](#)
- [Specials](#)
- [High Security Locks](#)
- [Fasteners](#)
- [Other Fence Hardware](#)
- [Search By Color](#)
- [Search By Mfr Code](#)
- [Help/FAQ](#)

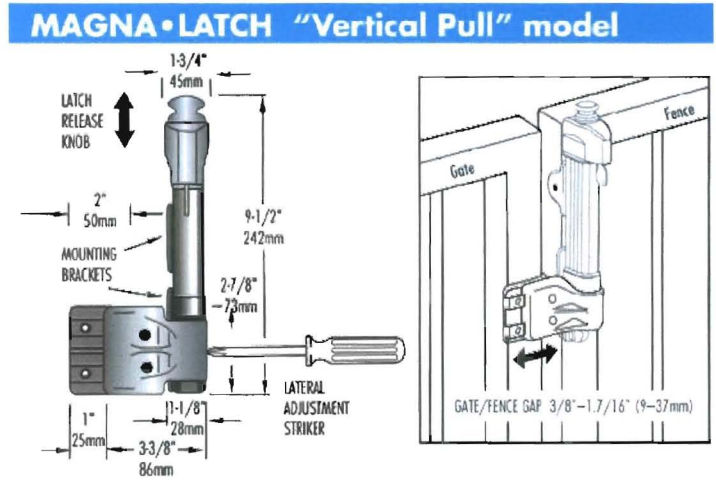

Quantity in Basket: None
Code: VGHDD1020WT

Price: **\$65.95**

Shipping Weight: 1.13 pounds
Color: Wht
Mfr#: MLVPS2WTBGA
52 available for immediate delivery

Other Information (opens in new window).
[Installation Instructions .PDF / 765K](#)
[Magna Latch Vertical Pull Video 3D Animation .MOV / 6.4MB](#)
[Pool Safety Video .MOV / 16MB](#)
[Quality Assurance Video .MOV / 12.6MB](#)
[Frequently Asked Questions](#)

You will need these free programs to view the above files.



LIVE HELP

Offline now
Leave us a message.

Quantity: 1

The Magna-Latch Vertical Pull is a magnetic lockable gate latch, that when used with Tru Close Hinges, meets or exceeds the most stringent of pool codes (BOCA). Comes with screws and easy to follow instructions. Lifetime Warranty!! This is the little brother to the Magna Latch Top Pull. Works with vinyl, wood and metal (square frame) gates. Can also be on chain link (round frame) gates when used in conjunction with the round post adaptor (CGHDD1026) Lifetime Warranty!!
Note - Works on a left or right swinging gate asseenontv



MEMBER NADPA
National Drowning Prevention Alliance

NOW ACCEPTING **PayPal**

Customers who purchased this product, also purchased:

Code	Name	Price
MGHDD1005WT	3 inch Tru Close Self Closing Hinge 2 legs - White (pair)	\$29.99 <input type="button" value="Add One to Basket"/>
VGHDD1039WT	5-1/2 inch Tru Close Self Closing Hinge 2 leg - White (pair)	\$32.95 <input type="button" value="Add One to Basket"/>
VGHDD1038WT	5-1/2 inch Tru Close Self Closing Hinge no leg - White (pair)	\$32.95 <input type="button" value="Add One to Basket"/>
MGHDD1003WT	3 inch Tru Close Self Closing Hinge no legs - White (pair)	\$29.99 <input type="button" value="Add One to Basket"/>
MGHDD1010WT	Mini Multi Tru Close Self Closing Hinge - White (pair)	\$54.95 <input type="button" value="Add One to Basket"/>

[Home](#)

[Basket](#)

[Magna Latch](#)

[Account](#)

[Checkout](#)

[Lokk Latch](#)

[Products](#)

[Return Policy](#)

[Z-Lokk](#)

[Help/FAQ](#)

[Contact Us](#)

[Tru Close](#)

[Visit Our Blog on Gate Hardware](#) | [Follow FenceMax on Twitter](#) | [Connect with FenceMax on FaceBook](#)

FenceMax.com
Gate Hardware Professionals
Since 1969
888-867-1139
toll free in U.S. & Canada

Home Products Help/FAQ Return Policy Contact Us Basket **Checkout**

Advanced Search

Tightens to 75 psi !! **FLEXI-CLAMP™**
Rust-Free • Re-usable • Non-conductive

McAfee SECURE™
TESTED DAILY 21-MAR

Tax Free Shopping !!
(& no sneaky handling charges)

[Sign In / Create Account](#)

[Wholesale Pricing Information](#)

Basket Contents

Quantity in Basket: none

[Recently Visited Items](#)



- [Gate Latch](#)
- [Gate Hinge](#)
- [Drop Rods](#)
- [Accessories](#)
- [Specials](#)
- [High Security Locks](#)
- [Fasteners](#)
- [Other Fence Hardware](#)
- [Search By Color](#)
- [Search By Mfr Code](#)
- [Help/FAQ](#)

LIVE HELP

Offline now
Leave us a message.

Send



[Home](#) > [Gate Hinge](#) > [Tru Close Hinge](#) > [Regular Duty](#) > 3 inch Tru Close Self Closing Hinge 2 legs - Black (pair)

3 inch Tru Close Self Closing Hinge 2 legs - Black (pair)

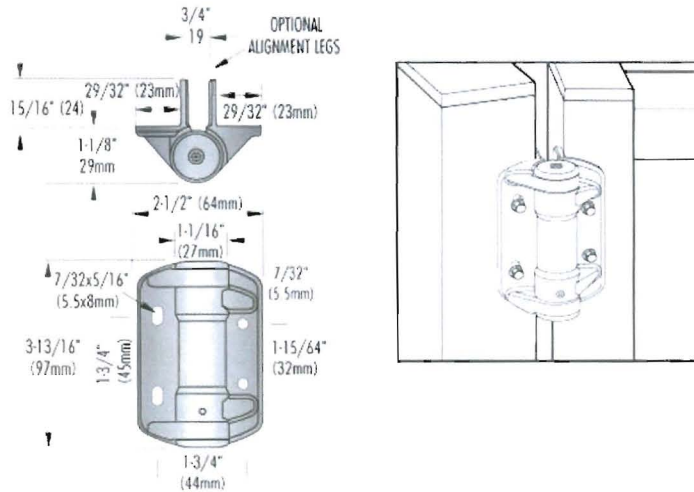

Quantity in Basket *None*
Code: **MGHDD1005**

Price **\$29.99**

Shipping Weight **0.54** pounds

Color **Blk**

Mfr#: **TCA1L2-Mk2**

Sorry, we are currently sold out of '3 inch Tru Close Self Closing Hinge 2 legs - Black (pair)' (MGHDD1005).
Please check back later

Other Information (opens in new window)

[Installation Instructions](#) .PDF / 270K

[Product Video](#) .MOV / 14.9MB

[3D Animation](#) .MOV / 4.3MB

[Pool Safety Video](#) .MOV / 16MB

[Quality Assurance](#)

[Video](#) .MOV / 12.6MB

[Frequently Asked Questions](#)

You will need these free programs to view the above files:



Need Fasteners? None

16 - Black Stainless Steel Self Drilling Screws for Metal or Vinyl ... add \$4.00

Quantity:

For regular range square frame gates weighing up to 55 lbs. Works best with ornamental aluminum or steel gate and fence materials. The 2 alignment legs help keep the hinges square to your gate and hinge post while at the same time adding additional strength by accepting extra screws. TRU CLOSE safety gate hinges are molded from special glass-fiber reinforced polymer materials. These UV-stabilized materials provide strong, rust-free hinges that won't bind, sag or stain! And they never require lubrication. The unique, spring-loaded adjuster within most TRU CLOSE hinges allows instant incremental tension adjustment using only a screwdriver. Quick, easy and safe! Please scroll down or select from the additional product pages below for more color and size options. Fasteners sold separately. asseenontv.truclose

Customers who purchased this product, also purchased:

Code	Name	Price
VGHDD1025	New Series 2 Magna Latch Top Pull - Black	\$65.99 <input type="button" value="Add One to Basket"/>
VGHDD1020	New Series 2 Magna Latch Vertical Pull - Black	\$62.95 <input type="button" value="Add One to Basket"/>
MGHDD1019	Residential Lokk Latch Series 2 no button - Black	\$25.95 <input type="button" value="Add One to Basket"/>
VGHDD1010	New Series 2 Magna Latch Side Pull - Black	\$23.95 <input type="button" value="Add One to Basket"/>





Pool Installation/Construction Permit Application

XV ✓

If you or the property owner owes real estate or personal property taxes or user charges on any property within the City, payment arrangements must be made before permits of any kind are accepted.

Location/Address of Construction: <u>4 Allison Avenue</u>		
Total Square Footage of Proposed Structure <u>512 Pool 120A Shed</u>	Square Footage of Lot <u>11,378</u>	
Tax Assessor's Chart, Block & Lot Chart# Block# Lot# <u>353 B2</u>	Owner: <u>Ronald and Jennifer Diome</u>	Telephone: <u>671-4281</u>
Lessee/Buyer's Name (If Applicable) <u>N/A</u>	Applicant name, address & telephone: <u>4 Allison Ave. Portland, ME 04103</u>	Cost Of Work: \$ <u>30,000</u> Fee: \$ <u>201.00</u> <u>320</u>
Dimensions of pool: <u>16x32</u> above or below ground: <u>Below</u>		
Dimensions of decking and/or any platforms, sheds, or other structures: <u>Shed 10x12 on concrete slab</u>		
Contractor's name, address & telephone: <u>Michaels Pool n' Patio 2010 Lisbon Rd Lewiston, ME 04240 782-1514</u>		
Who should we contact when the permit is ready: <u>Jennifer Diome</u>		
Mailing address: <u>4 Allison Ave. Portland, ME 04103</u> Phone: <u>671-4281</u>		

S402 P

Please submit all of the information outlined in the pool application checklist. Failure to do so could result in the automatic denial of your permit.

In order to be sure the City fully understands the full scope of the project, the Planning and Development Department may request additional information prior to the issuance of a permit. For further information visit us on-line at www.portlandmaine.gov, stop by the Building Inspections office, room 315 City Hall or call 874-8703.

I hereby certify that I am the Owner of record of the named property, or that the owner of record authorizes the proposed work and that I have been authorized by the owner to make this application as his/her authorized agent. I agree to conform to all applicable laws of this jurisdiction. In addition, if a permit for work described in this application is issued, I certify that the Code Official's authorized representative shall have the authority to enter all areas covered by this permit at any reasonable hour to enforce the provisions of the codes applicable to this permit.

Signature of applicant: <u>Jennifer Diome</u>	Date: <u>MAR 24 2011</u>
---	--------------------------

RECEIVED
MAR 24 2011
Dept. of Building Inspections
City of Portland Maine

This is not a permit; you may not commence ANY work until the permit is issued.

Dionne Pool Installation/Construction Permit Application

**4 Allison Avenue
Portland, Maine 04103**

1. Plot Plan
2. Structural details, size and dimensions of Pool
3. Construction details for shed
4. Design of fencing, gates, latches, and audible alarms
5. Proof of Ownership

From: <rdionne4@maine.rr.com>
To: <amachado@portlandmaine.gov>
Date: 3/31/2011 6:48 AM
Subject: 4 Allison Avenue - Pool Permit Application

Ann,

The setback for the shed from the rear property is 10' and the setback from the side property line is 21'. Please let me know if you need any additional information.

Jen

RECEIVED

MAR 31 2011

Dept. of Building Inspections
City of Portland Maine

3/25/11

Job Summary Report
Job ID: 2011-03-667-POOL

Report generated on Mar 25, 2011 2:28:10 PM

Job Type:	Pool	Job Description:	4 Allison	Job Year:	2011
Building Job Status Code:	Initiate Plan Review	Pin Value:	966	Tenant Name:	
Job Application Date:		Public Building Flag:	N	Tenant Number:	
Estimated Value:	30,000	Square Footage:			
Related Parties:		JENNIFER S DIONNE		<i>Property Owner</i>	
		Michael's Pool n' Patio - Michael's Pool n' Patio	Michael's	<i>GENERAL CONTRACTOR</i>	
		Pool n' Patio			

Job Charges

Fee Code Description	Charge Amount	Permit Charge Adjustment	Net Charge Amount	Payment Date	Receipt Number	Payment Amount	Payment Adjustment Amount	Net Payment Amount	Outstanding Balance
----------------------	---------------	--------------------------	-------------------	--------------	----------------	----------------	---------------------------	--------------------	---------------------

Location ID: 37804

Location Details

Alternate Id	Parcel Number	Census Tract	GIS X	GIS Y	GIS Z	GIS Reference	Longitude	Latitude
P14400	353 B 001 001		M				-70.300626	43.711818

Location Type	Subdivision Code	Subdivision Sub Code	Related Persons	Address(es)
1				4 ALLISON AVENUE NORTH

Location Use Code	Variance Code	Use Zone Code	Fire Zone Code	Inside Outside Code	District Code	General Location Code	Inspection Area Code	Jurisdiction Code
SINGLE FAMILY		NOT APPLICABLE	R2				DISTRICT 8	NORTH DEERING

Structure Details

Structure: Single Family Home

Occupancy Type Code:

Structure Type Code	Structure Status Type	Square Footage	Estimated Value	Address
Single Family	0			4 ALLISON AVENUE NORTH

Longitude	Latitude	GIS X	GIS Y	GIS Z	GIS Reference	User Defined Property Value
-----------	----------	-------	-------	-------	---------------	-----------------------------

Permit #: 20112181

Permit Data

Location Id	Structure Description	Permit Status	Permit Description	Issue Date	Reissue Date	Expiration Date
37804	Single Family Home	Initialized	16' x 32' inground Pool & 10' x 12' Shed			

Job Summary Report
Job ID: 2011-03-667-POOL

Report generated on Mar 25, 2011 2:28:10 PM

Page 2

Inspection Details

Inspection Id	Inspection Type	Inspection Result Status	Inspection Status Date	Scheduled Start Timestamp	Result Status Date	Final Inspection Flag
---------------	-----------------	--------------------------	------------------------	---------------------------	--------------------	-----------------------

Fees Details

Fee Code Description	Charge Amount	Permit Charge Adjustment	Permit Charge Adj Remark	Payment Date	Receipt Number	Payment Amount	Payment Adjustment Amount	Payment Adj Comment
Job Valuation Fees	\$320.00							

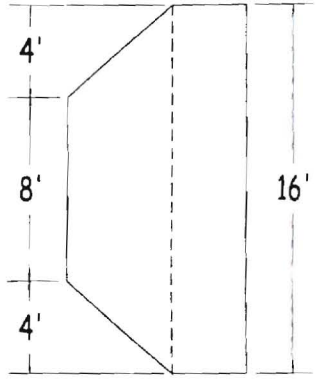
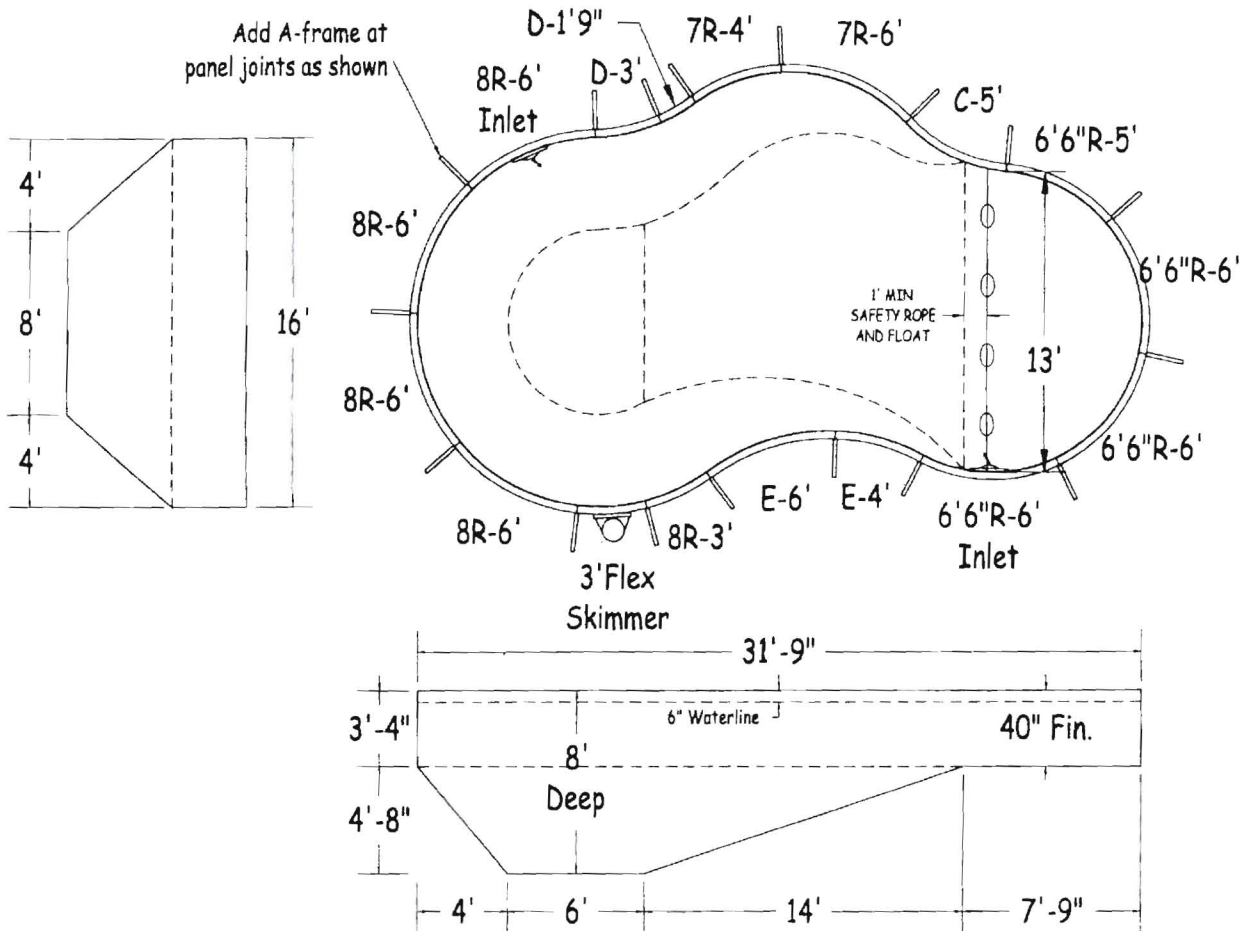

Add A-frame at panel joints as shown

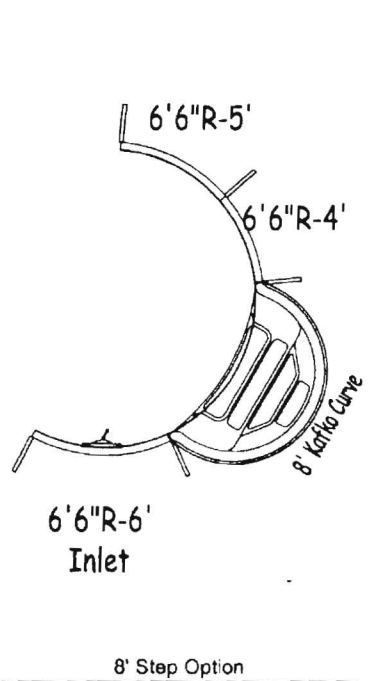
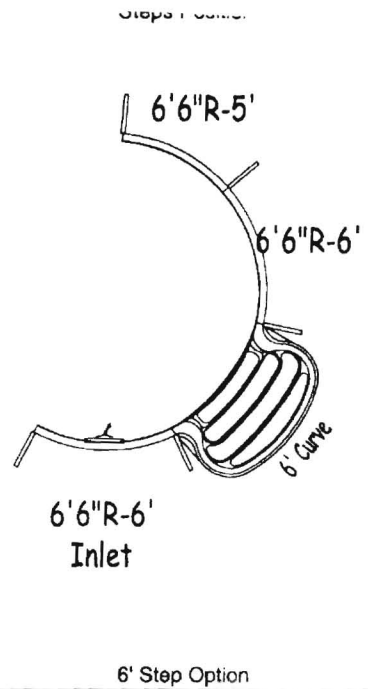

		STEEL	
Tahiti 16' x 32' Left			
DWG #:	KAMLS42-1632-8'H_08L	AREA (SqFt):	428
VOLUME (US Gal):	15 800	PERIMETER:	82'-10"
VOLUME (Litres):	59 800	DATE:	01/Jan/2008
		SAFETY COVER (SqFt):	757
		SCALE:	1/8" = 1'

Feet FirstTM

MEETS DEPTH AND SHAPE MINIMUM STANDARD ANS/NSPI-2003

DIVING/SLIDING EQUIPMENT SHALL BE DESIGNED FOR SWIMMING POOLS AND SHALL BE INSTALLED IN ACCORDANCE WITH THE DIVING/SLIDING EQUIPMENT MANUFACTURER'S SPECIFICATIONS PLEASE CONTACT THE DIVING/SLIDING EQUIPMENT MANUFACTURER FOR THEIR SPECIFICATIONS

Tahiti

- [Home](#)
- [FAQ's](#)
- [Directions](#)
- [Catalog Page](#)
- [Delivery](#)
- [Site Preparation](#)

Site Search:

[GO >>](#)

Home



We are a Family Owned & Operated, Wood Furniture manufacturing and distribution company. With careful attention paid to both quality workmanship and quality customer service, we are here to provide the products you need to make your home and yard the wonderland you would like it to be.

With over 100 years experience in two generations, we know how to do it right. From selecting and cutting the trees, to the finished product, we do it all.

If you have any questions feel free to call Richard anytime, 207-786-3304

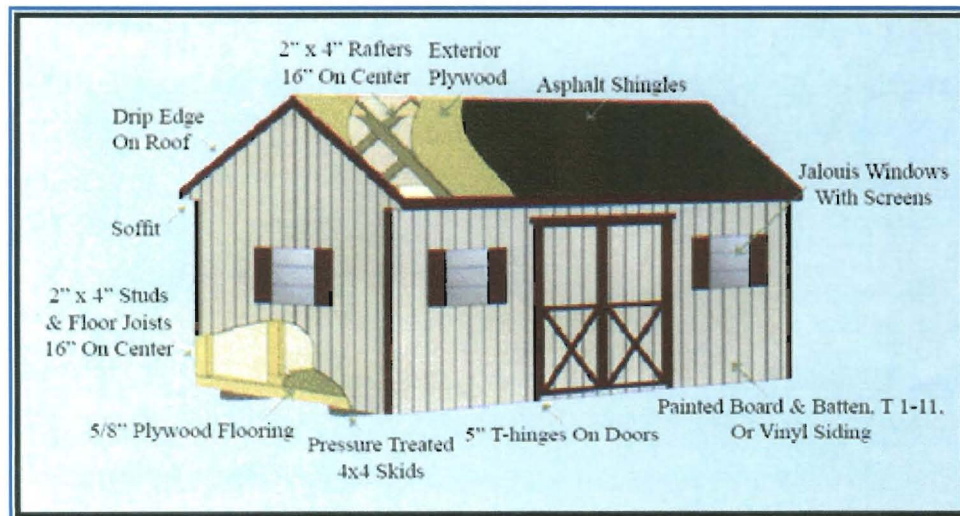

*These buildings are strong enough to accommodate the heavier lawn and garden tractors. They will withstand severe wind and snow. The pressure treated skids will not rot and facilitate moving the shed if necessary. *

2008

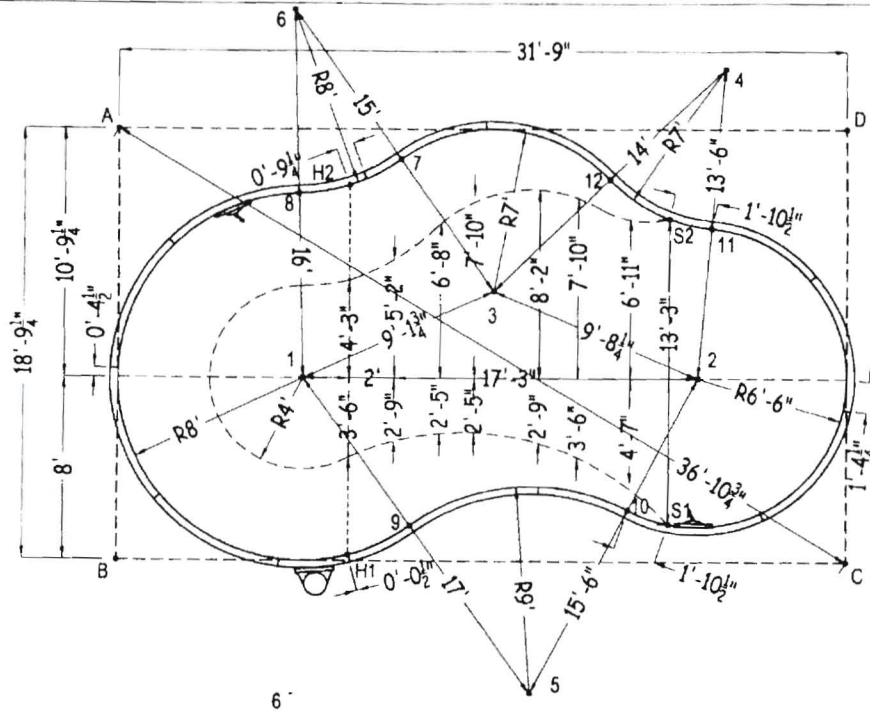

Part number	Description	Qty
02-CP06A-08	8R-6'	3
02-CI06A-08	8R-6' Inlet	1
02-CP03A-08	8R-3'	1
02-CP06A-07	7R-6'	1
02-CP04A-07	7R-4'	1
02-CP06A-06M	6'6\"R-6'	2
02-CI06A-06M	6'6\"R-6' Inlet	1
02-CP05A-06M	6'6\"R-5'	1
02-CP04A-06M	6'6\"R-4'	-
02-RP05A-07	C-5'	1
02-RP03A-08	D-3'	1
02-RP01T-08	D-1'9"	1
02-RP06A-09	E-6'	1
02-RP04A-09	E-4'	1
02-CK03A-00	3' Flex Skimmer	1
	6' Curve Step	-
	8' Kafko Curve Step	-
A-Frame	A-Frame Multiplier	17
15-0632-9	Optional Deck Supports	22

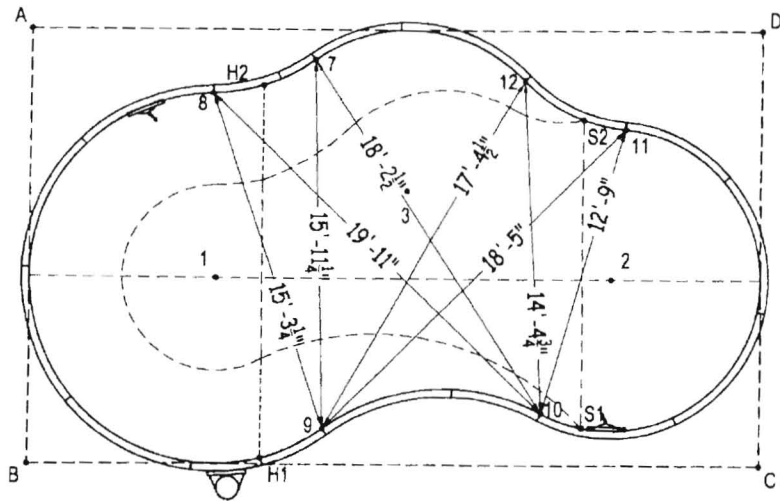

	A	B	C	D
1	13'-5"	11'-3 3/4"	25'-0 3/4"	26'-1"
2	27'-5 1/2"	26'-5 3/4"	10'-3 3/4"	12'-7"
3	17'-9 1/4"	20'-1 1/2"	19'-4 3/4"	16'-11 1/4"
4	26'-7"	34'-0 3/4"	22'-1"	5'-11 1/4"
5	30'-5"	18'-11"	14'-10 1/4"	28'-1"
6	9'-3"	25'-2 1/4"	34'-0 1/4"	24'-8 1/4"
7	12'-4"	21'-4 1/4"	26'-2"	19'-6 1/4"
8	8'-3 1/2"	17'-9 3/4"	28'-9 1/2"	24'-1 1/4"
9	21'-5"	12'-9 3/4"	19'-1"	25'-8"
10	27'-8 1/2"	22'-4"	9'-9 1/2"	19'-1"
11	26'-2 1/4"	29'-7 1/4"	15'-7 3/4"	7'-3 3/4"
12	21'-6"	27'-1"	19'-7"	10'-7"
H1	21'-0 1/2"	10'	21'-9"	28'-6 3/4"
H2	10'-3 1/2"	19'-2"	27'-2 1/2"	21'-10 1/2"
S1	29'-6"	24'-0 3/4"	7'-11"	18'-10"
S2	24'-3 3/4"	28'-3"	16'-9 1/2"	8'-8"
A	-	18'-9 1/4"	36'-10 3/4"	31'-9"

Find

POOLGUARD WIRELESS DOOR ALARM: MODEL DAPT-WT

Find a Dealer

- > Home
- > Pool Fences
- > Pool Nets
- > Pool Covers
- > Pool Alarms
 - > Pool Alarms
 - > **Door & Gate Alarms**
 - > Child Safety Alarms
 - > View All Alarms
 - > Help Center
- > Pet Safety
- > Pool Supplies
- > Pool Safety Resources

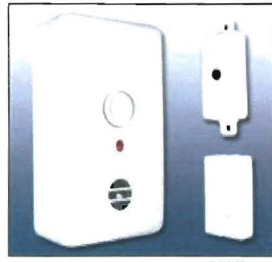

Model number: ALARM-DAPTWT

- Alarm sounds immediately when door opens.
- Outdoor wireless transmitter pass-thru feature.
- UL Listed / UL 2017.
- Easy installation.
- One-year manufacturer warranty.

Price: \$68.99



zoom

> ESTIMATED DELIVERY TIME
Usually ships within 24 hours.

Description	Features	More Information
-----------------------------	--------------------------	----------------------------------

- The **Door Alarm** will sound immediately when a child opens the door, and will continue to sound if the door is left open. If a child goes through the door and closes it, the alarm will sound for five minutes and then automatically reset.
- **Poolguard Door Alarm** Model DAPT-WT is equipped with an Outdoor Wireless Transmitter that allows adults to enter the home from the outside without the alarm sounding, and is easy to install.
- The **Door Alarm** is always on and will automatically reset under all conditions.
- **Poolguard Door Alarm** is equipped with an adult pass through feature that will allow adults to go through the door without the alarm sounding.
- Optional screen door kits can be purchased for the alarm, this kit allows you to get air through your screen door without the alarm sounding.
- **Poolguard Door Alarm** uses one 9-volt battery (not included).
- The **Door Alarm** is equipped with a low battery indicator that will audibly alert you when your battery is getting low.
- The **Poolguard Door Alarm** is UL listed under UL 2017 for water hazard entrance alarm equipment.

"What a fantastic hard working crew and great customer service. The Safety Net looks so good! My wife and I could not be happier!"
-Steven,
 Moreno Valley, CA

RELATED ITEMS



Poolguard Screen Door Kit



Poolguard Door Alarm: Model DAPT-2

FAX



To: **Michael's Pool 'n' patio Inc**

Fax Number : **(207)795-6842**

From: Jonathan Rioux, Code Enforcement Officer/ Plan Reviewer

Fax Number: **(207) 874-8716**

Date: **04/15/2011**

Regarding: **Pool Barrier Code**

Total Number Of Pages Including Cover: **Five (5)**

Phone Number For Follow-Up: **(207) 874-8702**

Attached is Sec. 6-24 Swimming Pools, Spas and Hot Tubs.

City Of Portland, Maine
Inspections Division Services
389 Congress St Room 315 Portland Me 04101-3509
Phone: (207) 874-8703 or (207)874-8693
Fax: (207) 874-8716
<http://www.portlandmaine.gov/>