



Reviewed for Code Compliance  
Inspections Division  
Approved with Conditions

44 Dole

The boiler is hung on a stud wall &  
cement wall with the factory brackets.

Date: 01/02/15

The vent kit is factory pipe within a pipe  
vent through the stud and cement wall  
18" off the ground and 18" under deck  
as per code.



Reviewed for Code Compliance  
Inspections Division  
Approved with Conditions

Date: 01/02/15

Chimney

Vent.

Boiler

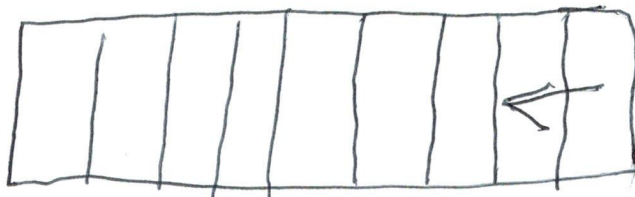

Open  
Basement

FILL IN AND SIGN WITH INK



Reviewed for Code Compliance  
Inspections Division  
Approved with Conditions



## HVAC / Power Equipment Checklis

All of the following information is required and must be submitted. Checking off each item on this checklist and preparing your application package will ensure your package is complete and will help to expedite the permitting process.

Date: 01/02/15

- A floor plan that includes structural details, size and dimensions of the floor the equipment is going to be installed.
- Information on how the unit is being vented & hanging details if appropriate.
- Details of the specific equipment being installed; ie; specifications and any heating technical specifications. Often this information can be obtained from the manufacturer's spec sheet or retail advertisements.
- A plot plan showing the shape and dimension of the lot, with the distance from the actual property lines, and the principal structure.
- Proof of ownership is required if it is inconsistent with the assessors records.

**All HVAC installations must be conducted in compliance with the  
IRC 2009 Building Code**

**Separate permits are required for plumbing and electrical installations, as required.**

**Separate permits are also required based on different properties (different Chart, Block and Lot.)**

**Permit Fee: \$25.00 for the first \$1000.00 construction cost, \$11.00 per additional \$1000.00 cost**

**This is not a Permit; you may not commence any work until the Permit is issued.**



Reviewed for Code Compliance  
Inspections Division  
Approved with Conditions

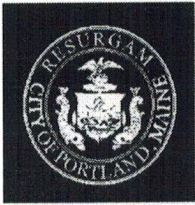

# PORTLAND MAINE

*Strengthening a Remarkable City, Building a Community for Life*

Date: 01/02/15

Jeff Levine, AICP, Director  
Director of Planning and Urban Development

Tammy Munson  
Director, Inspections Division

### Electronic Signature and Fee Payment Confirmation

Notice: Your electronic signature is considered a legal signature per state law.

By digitally signing the attached document(s), you are signifying your understanding this is a legal document and your electronic signature is considered a **legal signature** per Maine state law. You are also signifying your intent on paying your fees by the opportunities below.

I, the undersigned, intend and acknowledge that no permit application can be reviewed until payment of appropriate permit fees are **paid in full** to the Inspections Office, City of Portland Maine by method noted below:

Within 24-48 hours, upon receipt of an e-mailed invoice from Building Inspections, which signifies that my electronic permit application and corresponding paperwork have been received, determined complete, entered by an administrative representative, and assigned a permit number, I then have the following four (4) payment options:

- to provide an on-line electronic check or credit/debit card (we now accept American Express, Discover, VISA, and MasterCard) payment (along with applicable fees beginning July 1, 2014),
- call the Inspections Office at (207) 874-8703 and speak to an administrative representative to provide a credit/debit card payment over the phone,
- hand-deliver a payment method to the Inspections Office, Room 315, Portland City Hall,
- or deliver a payment method through the U.S. Postal Service, at the following address:

City of Portland  
Inspections Division  
389 Congress Street, Room 315  
Portland, Maine 04101

Once my payment has been received, this then starts the review process of my permit. **After all approvals have been met and completed, I will then be issued my permit via e-mail.** No work shall be started until I have received my permit.

Applicant Signature: [Signature] Date: 12-19-14

I have provided digital copies and sent them on: PDF Date: 12-19-14

NOTE: All electronic paperwork must be delivered to [buildinginspections@portlandmaine.gov](mailto:buildinginspections@portlandmaine.gov) or by physical means ie; a thumb drive or CD to the office.

**Room 315 - 389 Congress Street- Portland, Maine 04101 (207) 874-8703 - Fax: 874-8716 - TTY: 874-8936**



FILL IN AND SIGN WITH INK

# Application for Heating, Ventilation, Air Condition (HVAC) Cooking or Power Equipment



Reviewed for Code Compliance  
Inspections Division  
Approved with Conditions

Date: 01/02/15

To the Inspector of Buildings, Portland Maine:

The undersigned hereby applies for a permit to install the following HVAC, cooking or power equipment in accordance with the Laws of Maine, the Building Code of the City of Portland, and the following specifications:

Address/CBL: 44 Dole Dr Use of Building: Home Date: 12-19-14  
 Name and Address of Owner: Mainley Properties LLC 15 Inspiration Dr Scarborough Me  
 Phone Number Owner: 636-6669 E-Mail: Owner: \_\_\_\_\_  
 Name and Address of Installer: Bono B Heating 6 Little Ossipee Landing N. Waterboro 1  
 Phone Number Installer: 207-636-6586 E-Mail: Installer: Service@bbheating.net 040

<p>Location of Appliance:  <input checked="" type="checkbox"/> Basement                      <input type="checkbox"/> Floor  <input type="checkbox"/> Attic                                      <input type="checkbox"/> Roof</p> <p>Type of Fuel:  <input checked="" type="checkbox"/> Gas                      <input type="checkbox"/> Oil                      <input type="checkbox"/> Solid</p> <p>Appliance Name: <u>Biasi Riva combi</u></p> <p>UL Approved: <input checked="" type="checkbox"/> Yes                      <input type="checkbox"/> No</p> <p>Will appliance be installed in accordance with the manufacturer's installation instructions? <input checked="" type="checkbox"/> Yes <input type="checkbox"/> No</p> <p>Type of License of Installer:        Master Plumber #: _____        Solid Fuel #: _____        Oil #: _____        Gas #: <u>pn4676</u>        Other: _____</p>	<p>Type of Venting: (Plan required for submittal)  <input type="checkbox"/> Masonry Lined  <input type="checkbox"/> Factory Built: _____  <input type="checkbox"/> Metal  <input checked="" type="checkbox"/> Factory Built UL Listing: _____  <input checked="" type="checkbox"/> Direct Vent        Type: _____ UL #: _____</p> <p># of Tanks: _____</p> <p>Type of Fuel Tank:  <input type="checkbox"/> Gas                                      <input type="checkbox"/> Oil</p> <p>Size of Tank: _____</p> <p>Distance from tank to center of flame: _____</p> <p>Cost of Work: \$ <u>7500.00</u></p> <p>Permit Fee: \$ <u>102.00</u></p>
---	--

Signature of Installer: Bono B Heating

E-Mail: Service@bbheating.net



Reviewed for Code Compliance  
Inspections Division  
Approved with Conditions

Date: 01/02/15



## RIVA PLUS

High efficiency condensing  
combination & system boiler





Reviewed for Code Compliance  
Inspections Division  
Approved with Conditions

Date: 01/02/15

# RIVA PLUS



The BIASI Riva Plus range has evolved from the already very successful Riva Compact HE MK2.

Extra efficiency is gained through the new recuperator heat exchanger designed by BIASI and the modulating fan that optimises the air/gas ratio.

The new recuperator has a coil inside that is covered by a multitude of fins, increasing the heat exchanging surface.

Riva Plus is available as a combination and system boiler in both 24kW and 28kW outputs.

## RECUPERATOR HEAT EXCHANGER

The recuperator takes the heat which is normally lost through the boiler flue to the outside air and uses it to preheat the boiler system water before it is heated by the burner.

Because the recuperator extracts this heat from the products of combustion, condensation is produced which is removed via a condensate drain.

The result is a tried and tested product with extra efficiency without the pain of a radical redesign. For your Installer and Service Engineer, they are dealing with a product that is easy to install and easy maintain.

## EFFICIENCY RATING

Changes to the UK Building Regulations in April 2005 made it compulsory for all new and replacement boilers installed to be high efficiency condensing boilers.

Riva Plus achieves 88% efficiency, giving it an A rating on the Sedbuk database, the efficiency rating scheme for all boilers available in the UK.

## TWO YEAR GUARANTEE

Riva Plus carries a full manufacturer's warranty of TWO YEARS, covering parts and labour. Our nationwide service network provides a quick and efficient response should any problems arise.

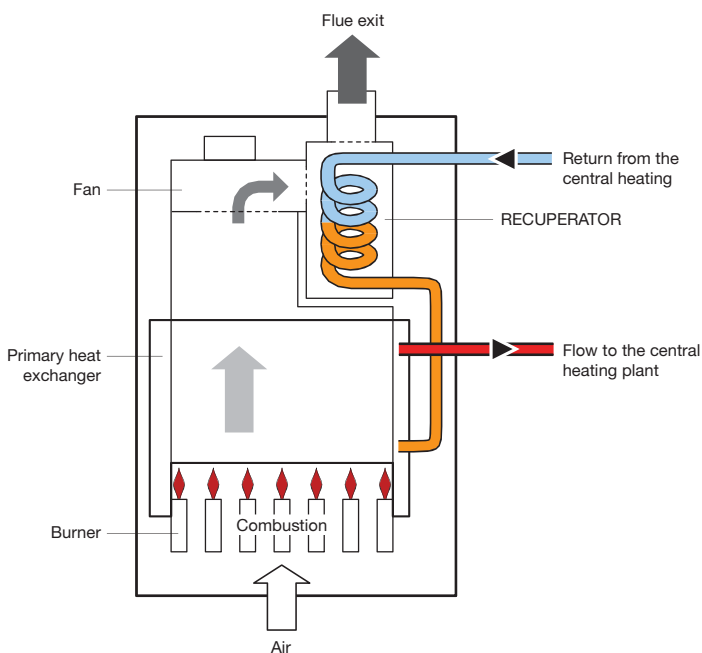

## CONTROL PANEL

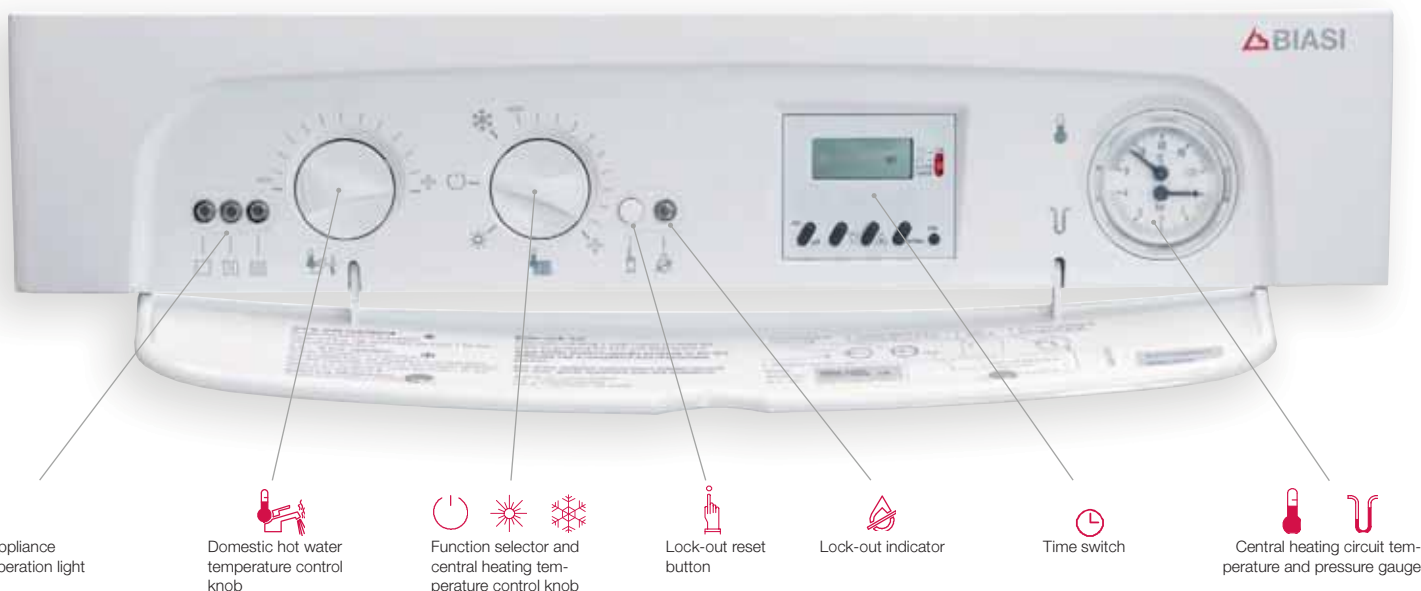

## WHY CHOOSE A BIASI COMBI OR SYSTEM BOILER?

Unlike a conventional domestic central heating and hot water system, a combi boiler heats water taken directly from the cold mains - but only as you use it.

It does not need a tank or a cylinder to store hot water.

The Riva Plus combi range is a compact boiler that:

- Saves space (it is a compact unit for central heating and domestic hot water).
- Saves on hot water costs.
- Delivers hot water through the taps or shower at mains pressure (a pump is not needed).
- Saves money on installation time and costs with quick and easy installation (tank not required).

Combination boilers are very popular in UK homes. In fact they account for around 75% of all boilers installed.

System boilers are more like traditional boilers, using a pipe work circuit to distribute heat to radiators for central heating, and a domestic hot water cylinder for all household hot water needs.

They are therefore ideal for replacing existing boilers and perfect for use with an unvented hot water cylinder, where the property has two or more bathrooms.

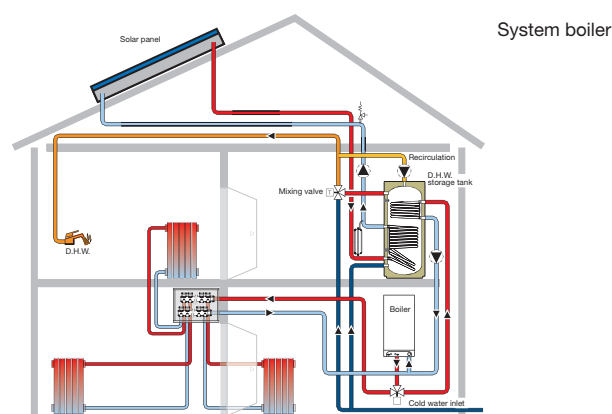
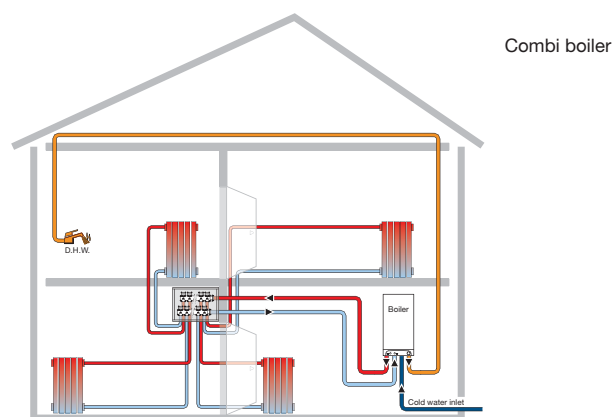





Reviewed for Code Compliance  
Inspections Division  
Approved with Conditions

Date: 01/02/15

# RIVA PLUS



## TECHNICAL FEATURES

- Compliant with all current UK building regulations.
- Fully modulating burner in both central heating and hot water modes to maintain an output within  $\pm 1$ deg C.
- Simple built-in controls with instructions on fold down panel for ease of use.
- Advanced electronic control board providing:
  - Electronic flame ignition
  - Adjustable re-ignition sequence
  - Circulation pump control
  - Aerobic exercise sequence which prevents any seizure of motorised components by exercising them during any 24 hour period without a demand for heating or hot water
  - Fault self-diagnostic indication via 3 LED lights for ease of maintainance
  - Frost protection system to prevent freezing when installed in vulnerable areas e.g. garage or roof space
- Automatic by-pass built in to protect the boiler if a low flow rate is present in system (e.g. all radiator valves shut).
- Magnetic hot water demand switch for long and maintenance-free life.
- Heating circuit pressure switch preventing ignition if system lacks water.
- Easily accessible electrical connection point.

## NEW RECUPERATOR

The new recuperator is made of aluminium and has an increased heat exchanging surface thanks to the coil with extra fins inside. In case of the condensate siphon being blocked, the boiler is locked by a safety device that checks to make sure that there is a clear air passage present for the flue gases.



## MODULATING FAN

Boiler efficiency is dependent upon the ratio of air to gas available at the burner. The controls of Riva Plus constantly monitor demand and temperature, adjusting the fan speed and gas to maintain the best ratio for maximum efficiency.



Reviewed for Code Compliance  
Inspections Division  
Approved with Conditions

Techn Date: 01/02/15



### HOT WATER HEAT EXCHANGER IN STAINLESS STEEL

A high performance plate heat exchanger that rapidly responds to hot water demand, providing up to 11.6 litres per minute (RIVA PLUS 28kW). Constructed in corrosion resistant stainless steel to ensure long life and reliability. By monitoring the temperature of the boilers system water, the Riva Plus will help reduce any build up of scale.



### ON BOARD SIPHON PROTECTION

Water produced by condensation during the combustion process is drained from the boiler through a siphonic safety trap. This device prevents any possible leakage of flue products by locking the boiler should a fault occur. Further protection is provided by a special ball which blocks the drain should no liquid be present.

If the condensate waste pipe is exposed to the weather, care must be taken to ensure the condensate waste pipe does not freeze during cold spells, as this will affect the operation of the boiler. Your heating engineer can advise you how to minimise the risks.

### FLUE CLEARANCE REQUIREMENTS

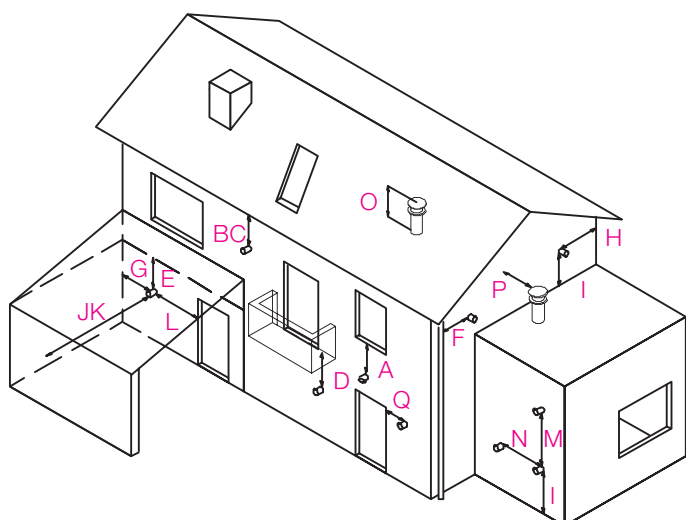

CLEARANCE REQUIREMENTS		mm
A	Directly below a window or other opening	300
B	Below gutters, soil pipes or drainpipes	75
C	Below eaves	200
D	Below balconies*	600
E	Below carport roof	NO
F	From vertical drainpipes and soil pipes	150
G	From internal corners**	450
H	From external corners	300
I	Above ground or balcony level	300
J	From a surface facing a terminal	600
K	From a terminal facing a terminal	1200
L	From an opening in the carport (e.g. door, window) into dwelling	NO
M	Vertically from a terminal in the same wall	1500
N	Horizontally from a terminal in the same wall	300
O	Above the roof pitch with roof slope less than or equal to 30°	350
	Above the roof pitch with roof slope more than 30°	600
P	From wall face	600
Q	From, above or to side of an opening	300

\* Wherever practical, the flue should be extended beyond the perimeter of the balcony.

\*\* Consideration should be given to adding protection against condensate to the adjacent structure.

# RIVA PLUS

Date: 01/02/15

## HYDRAULIC SCHEME

1. Condensate drainpipe
2. Fan
3. Flue temperature probe NTC
4. Condensing heat exchanger
5. Pump
6. C.H. pressure relief valve
7. D.H.W. flow switch (not system model)
8. Modulation gas valve
9. Three-way diverter valve (not system model)
10. D.H.W. heat exchanger (not system model)
11. Primary circuit pressure switch
12. Flame-detecting electrode
13. Burner
14. Ignition electrodes
15. Primary heat exchanger
16. C.H. expansion tank
17. By-pass valve

## FIXING HOLES & CONNECTION PIPES POSITION

- A - Air intake / flue outlet pipe (co-axial)
- B - Flue outlet pipe  $\varnothing$  80 mm (twin kit)
- C - Air intake pipe  $\varnothing$  80 mm (twin kit)
- S - Condensate drain connection area
- MR - C.H. flow
- US - D.H.W. outlet
- ES - Cold water inlet
- RR - C.H. return

A siphon is fitted within the boiler to collect condensate liquid from the condensing heat exchanger.

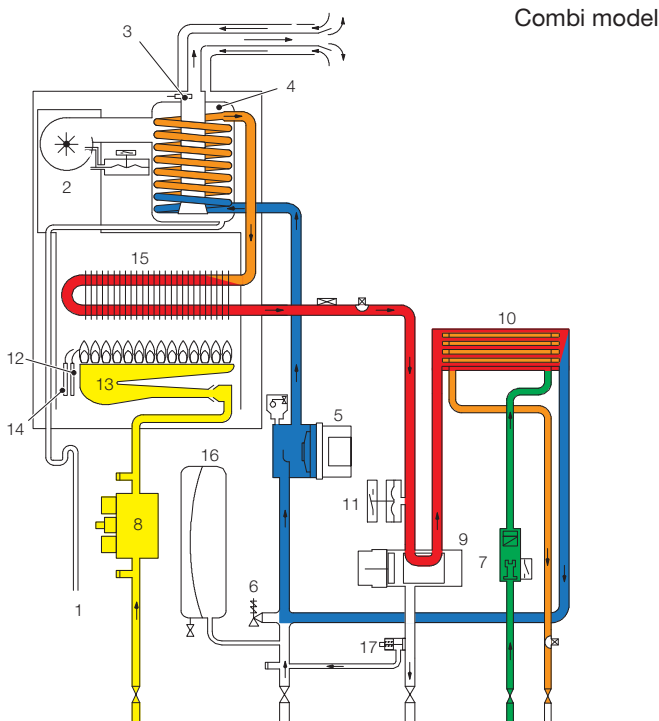

Combi model

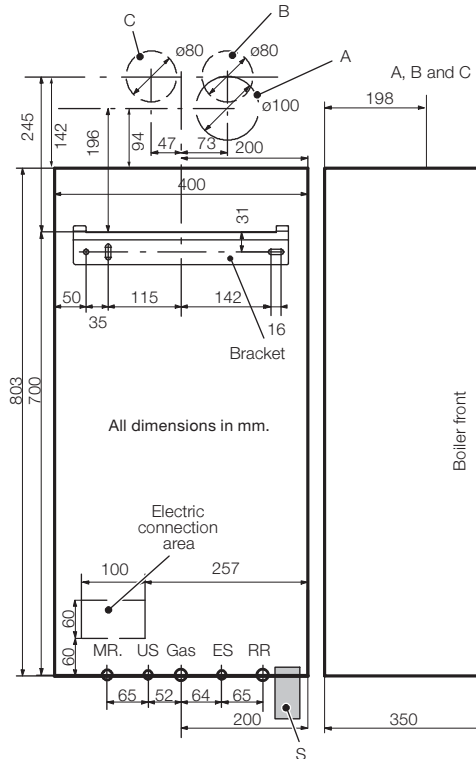

## OPTIONALS

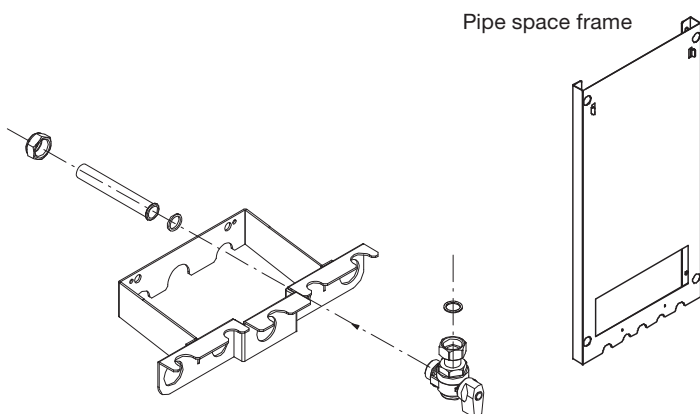





Prefixing kit

RIVA PLUS		Combi/System 24	Combi/System 28
Height	mm	803	803
Width	mm	400	400
Depth	mm	350	350
Weight	kg	42.5	44.5
C/H Flow & Return connections	mm	22	22
Gas inlet connections	mm	22	22
DHW Inlet & Outlet connections	mm	15	15
Condensate drain (plastic)	mm	25	25

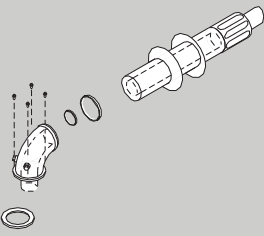
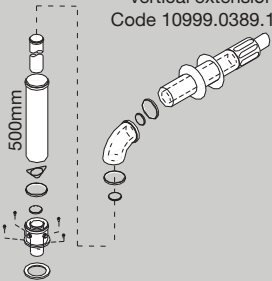
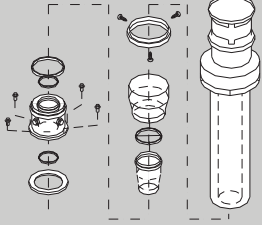
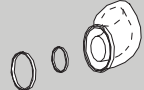

Reviewed for Code Compliance  
Inspections Division  
Approved with Conditions

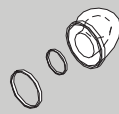
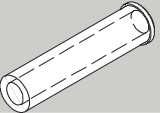
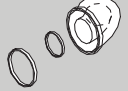
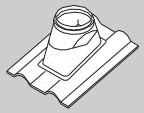
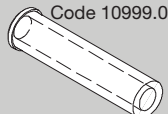
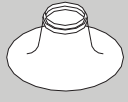
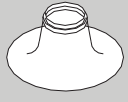
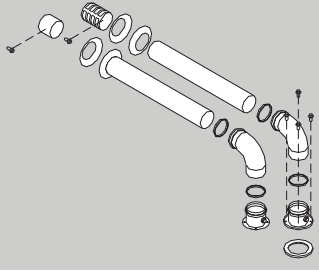
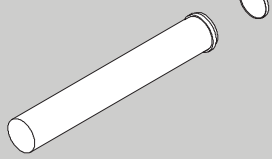
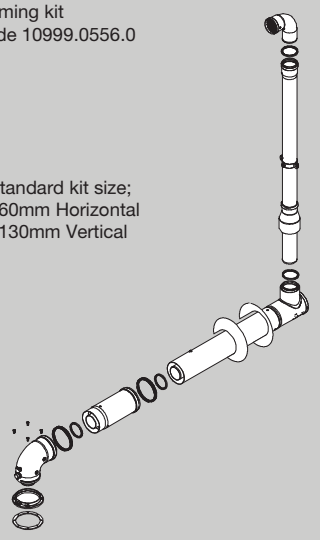
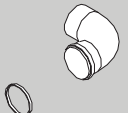
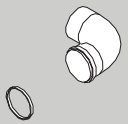
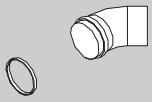
Flu Date: 01/02/15

<b>HORIZONTAL KITS</b> <b>KIT 1</b> Horizontal coaxial flue kit Ø 60 / 100 mm Code 10999.0387.1 		<b>KIT 2</b> Coaxial flue kit with vertical extension Code 10999.0389.1 		<b>VERTICAL KIT</b> <b>KIT 3</b> Coaxial roof kit Ø 80 / 125 mm Code 10999.0392.1 		Coaxial 90° elbow Ø 80 / 125 mm Code 10999.0408.1 	
Coaxial 90° elbow Ø 60 / 100 mm Code 10999.0390.1 		Coaxial 45° elbow Ø 60 / 100 mm Code 10999.0391.1 		Extension Ø 60 / 100 mm 1m length Code 10999.0388.1 2m length Code 10999.0928.0 		Coaxial 45° elbow Ø 80 / 125 mm Code 10999.0409.1 	
Max flue length Min flue length 90° bend is equivalent to 45° bend is equivalent to		2.7 m* 0.5 m* 1.0 m 0.5 m		<b>Pitched roof flashing plate</b> for roof kit Ø 80 / 125 mm Code 10999.0252.1 		<b>Extension</b> Ø 80 / 125 mm 1m length Code 10999.0407.1 	
Max flue length Min flue length 90° bend is equivalent to 45° bend is equivalent to		8.5 m* 0,5 m* 1.0 m 0,5 m		<b>Flat roof flashing plate</b> for roof kit Ø 80 / 125 mm Code 10999.0280.1 		<b>Flat roof flashing plate</b> for roof kit Ø 80 / 125 mm Code 10999.0280.1 	
<b>TWIN FLUE KIT</b> <b>KIT 4</b> Twin kit Ø 80 mm Code 10999.0393.1 		Extension Ø 80 mm Code 10999.0394.1 		<b>PLUMING KIT</b> <b>KIT 5</b> Plumbing kit Code 10999.0556.0 		90° elbow FM Ø 60 mm Code 10999.0558.0 	
90° elbow FM Ø 80 mm Code 10999.0395.1 		45° elbow FM Ø 80 mm Code 10999.0396.1 		Standard kit size; 960mm Horizontal 1130mm Vertical		45° elbow FM Ø 60 mm Code 10999.0559.0 	
Max flue length Min flue length 90° bend is equivalent to 45° bend is equivalent to		30.0m* 0,5 m* 1.65 m 0.90 m		Max plumbing kit length 90° bend is equivalent to 45° bend is equivalent to 90° bend is equivalent to 45° bend is equivalent to		Refer to manual 0.85 m (Ø 60 mm) 0.65 m (Ø 60 mm) 1.00 m (Ø 60/100 mm) 0.50 m (Ø 60/100 mm)	

\*Subject to clearances



Reviewed for Code Compliance  
Inspections Division  
Approved with Conditions

Date: 01/02/15

# TECHNICAL DATA

RIVA PLUS		24 Combi	28 Combi	24 System	28 System
<b>CENTRAL HEATING</b>					
Heat Input gross	KW	27.8	32.2	27.8	32.2
Maximum Heat Output	BTU/KW	83256/24.4	96564/28.3	83256/24.4	96564/28.3
Seasonal Efficiency Rating (SAP 2009)	%	88	88	88.1	88.1
Part L Compliant		✓	✓	✓	✓
Minimum/Maximum heating temperature	C	50-85	50-85	50-85	50-85
Minimum/Maximum heating pressure	Bar	0.3-2.5	0.3-2.5	0.3-2.5	0.3-2.5
<b>DOMESTIC HOT WATER</b>					
Flow rate at 35C deg rise	L/min	10	11.6	n/a	n/a
Minimum/maximum DHW Temp	C	35-55	35-55	n/a	n/a
Minimum/maximum DHW Pressure	Bar	0.3-10	0.3-10	n/a	n/a
<b>OTHER DATA</b>					
NOX class		2	2	2	2
Nox emmions	ppm	94	90	94	90
Electric protection	IP	IPX4D	IPX4D	IPX4D	IPX4D
Nominal Voltage/Power Consumption	V/W	230/140	230/150	230/140	230/150
Integral 24 hour time control		✓	✓	n/a	n/a
Self diagnostic LED indicators		✓	✓	✓	✓
Full flame modulation		✓	✓	✓	✓
Built in frost protection		✓	✓	✓	✓
Ventilation free compartment installation		✓	✓	✓	✓
Multi directional flueing options		✓	✓	✓	✓
Electronic flame ignition		✓	✓	✓	✓
Buit-in system by-pass		✓	✓	✓	✓
Anti seize component protection		✓	✓	✓	✓
Anti cycling control		✓	✓	✓	✓
LPG Conversion kit Part no. KI1064 506		Optional	Optional	Optional	Optional
Plume management Kit		Optional	Optional	Optional	Optional
Pipe space frame option for rear piping		Optional	Optional	Optional	Optional
Pre-piping kit		Optional	Optional	Optional	Optional
Weight	Kg	42.5	44.5	42.5	44.5
Power consumption on standby	W	3	3	3	3

Riva Plus carries a full manufacturers warranty of TWO YEARS covering parts and labour.



Biasi boilers are manufactured in one of Europe's most advanced facilities and over many years have earned a deserved reputation for quality and reliability.

Each boiler and its components are individually tested to exacting performance standards before leaving the factory.

Biasi UK provides nationwide customer service for fast and efficient response to after sales requests. Several extended warranty and servicing options are available. Genuine replacement parts are readily available from a network of country wide stockists.

