

1 RIGHT ELEVATION — NORTH WEST SIDE
SCALE: 1/4" = 1-0"

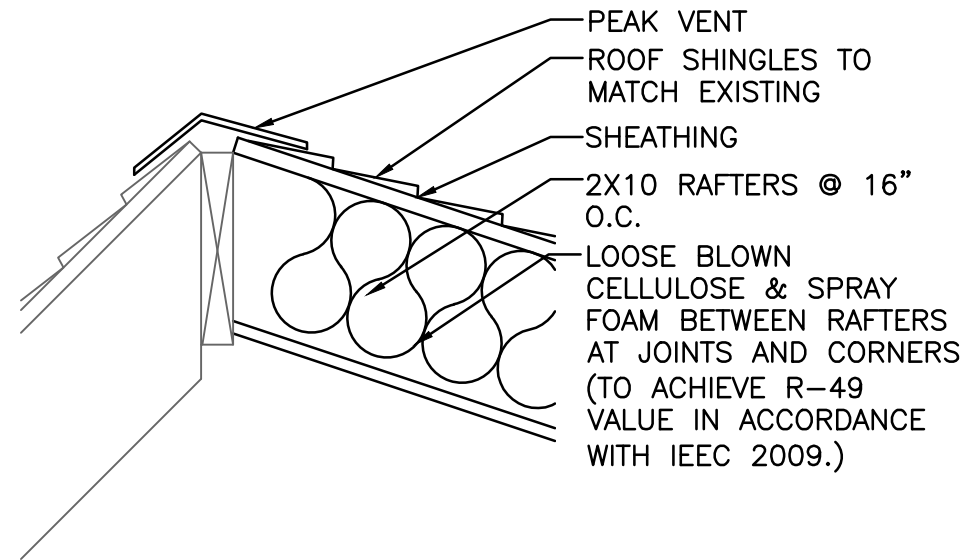

2 ROOF PEAK DETAIL
SCALE: 1" = 1-0"

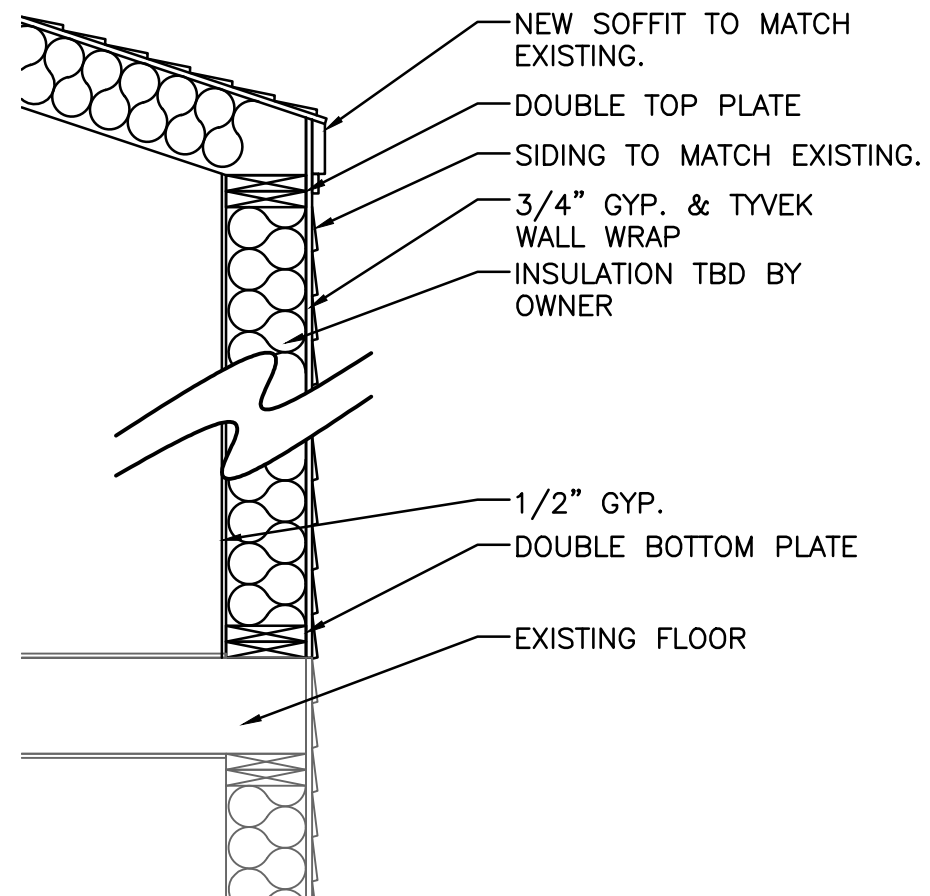

3 NEW WALL DETAIL
SCALE: 1" = 1-0"

NOTES:

1. SEE A0 FOR GENERAL NOTES.

NEW/EXISTING KEY

— EXISTING
— NEW CONSTRUCTION



PREPARED BY:	76 PENNELL AVE, PORTLAND, ME
JAKE DESJARDINS 68 CHAPEL ST SOUTH PORTLAND, ME 207-332-9949 yjagoman@gmail.com	DEMO PLAN SCALE: AS NOTED DATE: 7/31/15
A1	SHEET: 2 of 6