



**HOME OWNER / INSTALLER
FOR YOUR SAFETY**
THIS MANUAL MUST BE READ IN ITS
ENTIRETY BEFORE OPERATING HEATER

RHFE-263FA

ENERGYSAVER

GAS DIRECT VENT WALL FURNACE

Owner's Operation and Installation Manual



WARNING: IF THE INFORMATION IN THIS MANUAL IS NOT FOLLOWED EXACTLY, A FIRE OR EXPLOSION MAY RESULT CAUSING PROPERTY DAMAGE, PERSONAL INJURY OR LOSS OF LIFE.

DO NOT STORE OR USE GASOLINE OR OTHER FLAMMABLE VAPORS AND LIQUIDS IN THE VICINITY OF THIS OR ANY OTHER APPLIANCE.

WHAT TO DO IF YOU SMELL GAS

- DO NOT TRY TO LIGHT ANY APPLIANCE.
- DO NOT TOUCH ANY ELECTRICAL SWITCH; DO NOT USE ANY PHONE IN YOUR BUILDING.
- IMMEDIATELY CALL YOUR GAS SUPPLIER FROM A NEIGHBOR'S PHONE. FOLLOW THE GAS SUPPLIER'S INSTRUCTIONS.
- IF YOU CANNOT REACH YOUR GAS SUPPLIER, CALL THE FIRE DEPARTMENT.

INSTALLATION AND SERVICE MUST BE PERFORMED BY A QUALIFIED INSTALLER, SERVICE AGENCY OR THE GAS SUPPLIER.

This appliance may be installed in an aftermarket, permanently located, manufactured home (USA only) or mobile home, where not prohibited by local codes.

This appliance is only for use with the type of gas indicated on the Rating Plate. This appliance is not convertible for use with other gases, unless a certified kit is used.

Rinnai

INSTALLER: MUST LEAVE MANUAL WITH UNIT AFTER INSTALLATION.
OWNER: RETAIN THIS MANUAL SAFELY FOR FUTURE REFERENCE.

WARNING

IMPROPER INSTALLATION, ADJUSTMENT, ALTERATION, SERVICE OR MAINTENANCE CAN CAUSE PROPERTY DAMAGE, PERSONAL INJURY OR LOSS OF LIFE. REFER TO THE OWNER'S INFORMATION MANUAL PROVIDED WITH THIS APPLIANCE. INSTALLATION AND SERVICE MUST BE PERFORMED BY A QUALIFIED INSTALLER, SERVICE AGENCY OR THE GAS SUPPLIER.

ENERGYSAVER RHFE-263FA Operation Manual

Table of Contents

	Page
FEATURES OF THE RHFE-263FA UNITS	1
SAFETY DEVICES	1
IMPORTANT POINTS / USAGE AND INSTALLATION MUSTS	3
DIMENSIONS	5
SPECIFICATIONS	6
SAFETY POINTS	8
GETTING TO KNOW YOUR NEW RHFE-263FA	10
CONTROL PANEL	11
CUT-AWAY DIAGRAM	12
NOTICE BEFORE INSTALLATION	13
INSTALLATION INSTRUCTIONS	14
GAS CONNECTION	15
CANADIAN VENT REGULATIONS	16
LOCATION / CLEARANCES	17
SLEEVE AND MANIFOLD INSTALLATION	19
FITTING UNIT	21
OPERATING INSTRUCTION LABEL	23
ADDITIONAL CUSTOMER OPERATING INFORMATION	24
TESTING	30
CHECK	30
PRE-SERVICE CHECK	31
TROUBLE SHOOTING	32
ERROR MESSAGES.....	33
MAINTENANCE / SERVICE	34
WIRING DIAGRAM	35
WARRANTY INFORMATION	36
SCHEMATIC DIAGRAM	38
PARTS LIST	43
RHFE-263FA FLOW DIAGRAM	47
EXTENDED FLUE PIPE KIT	48
TECHNICAL DATA	52

FEATURES OF THE RHFE-263FA UNITS

Clean Heating Forced Flue Type
Easy Operation One-Touch Ignition
Sensible Temperature Control Feature
Comfortable Room Temperature Control and Display
Warm Air Outlet at Floor Level (Keeps Your Feet Warm)
Child Safety Lock
Room Temperature Setting Memory
Dirty Air Filter Indicator Lamp
Energy-Saving Economy Setting
Humidifier Tray
Air Flow Directional Louvers
Direct Vent Easily Installed
Proportional Heating Variable Capacity
Hush! Quiet Operation
Modern Design Minimizes Floor Space Requirements
Failure Message Display

SAFETY DEVICES

Spark Safety Device: Automatically shuts unit down when there is an abnormal spark at time of ignition.

Flame Failure Device: Activated when burner flame fails. This prevents raw gas from being released.

Overheat Switch: This device automatically cuts the gas off if the heater exceeds a predetermined temperature. This is normally caused by an obstruction in front of the louvers, or a blocked fan filter.

Fusible Links: Backs up the overheat switch. If the fusible link cuts the unit off, a service call by an authorized person is required to replace the link.

Overcurrent Prevention Device: This is a 3 amp. glass fuse found on P.C. board. Designed to shut unit down in case of overcurrent. If fuse blows, all indicator lamps will be "OFF".

Power Outage Safety Device: This safety device cuts off gas passage and stops operation.

Local and state codes must be adhered to prior to installation.

Rinnai is continually updating and improving products. Therefore, specifications are subject to change without prior notice.

	NAT.	LPG
Minimum supply gas pressure	3.5" (89mmH ₂ O)	8.0" (203mmH ₂ O)
Maximum supply gas pressure	10.5" (267mmH ₂ O)	13.0" (330mmH ₂ O)
Manifold test pressure	Factory set	Factory set

See conversion for setting gas pressures.

*There are two 1/8" NPT test points for measuring differential pressure, one is located on the modulating gas valve, the other is located on the burner manifold. The minimum inlet gas supply pressure is for the purposes of input adjustment.

GENERAL INFORMATION



THIS SERIES HEATER IS DESIGN CERTIFIED BY CSA INTERNATIONAL AS A DIRECT VENT WALL FURNACE AND MUST BE INSTALLED ACCORDING TO THESE INSTRUCTIONS. ALTERATION OF THE ORIGINAL DESIGN INSTALLED OTHER THAN AS SHOWN IN THESE INSTRUCTIONS OR USED WITH A TYPE OF GAS NOT SHOWN ON THE RATING PLATE, IS THE RESPONSIBILITY OF THE PERSON AND COMPANY MARKING THE CHANGE.

Thank you for purchasing a Rinnai gas forced flue heater.

Before using this product, please read this manual carefully to insure proper use of the product.

Please read the attached warranty thoroughly and keep it in a safe place.

IMPORTANT POINTS / USAGE AND INSTALLATION MUSTS

Unpack heater and check for damage. (DO NOT INSTALL DAMAGED HEATER.) If heater is damaged, contact your supplier for advice. Before installing a heater, check the label for the correct gas type (see label on heater). Refer to local gas authority for confirmation of gas type if you are in doubt.

Included in Carton:

Customers Operating Information
Manual valve set

IMPORTANT

Before using this product, please read this manual carefully to insure proper use of product.

1. The installation must conform with local codes or, in absence of local codes, the National Fuel Gas Code, ANSI Z223.1 or the Canadian Installation Code, CAN/CGA-B149.
2. For information on gas type, see data plate on the appliance.
3. This heater must not be installed where curtains or other combustible materials could come into contact with it. In some cases curtains may need restraining.
4. This appliance is not designed to be built in.
5. If you move, check the gas type in the area where you are moving to. The local gas authority will be able to advise on local regulations.
6. This heater discharges a large volume of warm air at low level to provide even heat distribution. If the air in the room contains cooking vapor or cigarette smoke, and the heater is used on a carpet, the surface of the carpet may become discolored. In addition, some nylon carpets contain dyes which may be affected by the warm air flow. Some soft vinyl surfaces are also subject to distortion, or discoloration by warm air. To prevent discoloration of carpets, etc., a mat should be placed under the appliance, extending about 30" (750mm) in front of it.

Diagram shows minimum clearances from combustible materials.

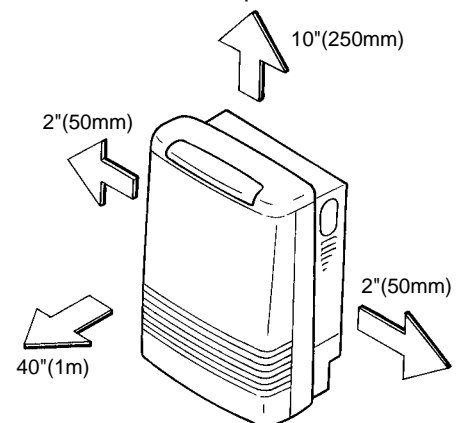

7. Read these rules and the instructions carefully. Check all local codes. Failure to follow these could cause a malfunction of the heater resulting in death, serious bodily injury and/or property damage.
8. This appliance is only for use with the type of gas indicated on the rating plate. This appliance is not convertible for use with other gases, unless a certified kit is used.
If a conversion of the unit is needed, conversions must be performed at Rinnai America or authorized agent at owner's expense.
9. **WARNING:** Any change to this heater or its controls can be dangerous.
10. If a gas leak is suspected, turn heater off, turn gas supply valve off at appliance connector valve. Open windows to ventilate area immediately and contact your dealer or gas company.
11. **DO NOT PLACE CLOTHING OR FLAMMABLE MATERIALS, GASOLINE AND OTHER FLAMMABLE VAPORS AND LIQUIDS, ON OR NEAR THE HEATER.**

12. YOUNG CHILDREN SHOULD BE CAREFULLY SUPERVISED WHEN THEY ARE IN THE SAME ROOM WITH THE HEATER.
13. LPG containers must not be installed indoors.
14. Do not use this room heater if any part has been under water. Immediately call a qualified service technician to inspect the room heater and to replace any part of the control system and any gas control which has been under water.
15. Adequate clearances for accessibility for purposes of servicing, proper operation and adequate combustion and ventilation air should be provided.
16. Adequate clearances around air openings should be provided.
17. Do not install in areas where curtains, drapes, clothing, or other moving flammables are within 10 inches of this unit.
18. Periodic examination of the venting system is required.
19. The flow of combustion and ventilation air should not be obstructed.
20. A manufactured home (USA only) or mobile home OEM installation must conform with the Manufactured Home Construction and Safety Standard, Title 24CFR, Part 3280, or, when such a standard is not applicable, the Standard for Manufactured Home Installations, ANSI Z225.1 or Standard for Gas Equipped Recreational Vehicles and Mobile Housing, CSA Z240.4.
21. "This appliance must be installed in accordance with the current standard CSA Z240.4 GAS EQUIPPED RECREATIONAL VEHICLES AND MOBILE HOUSING. Cet appareil doit être installé conformément aux exigences de la norme Z240.4 en vigueur de l'ACNOR, Installations de gaz dans les constructions mobiles et véhicules récréatifs."
22. If a blockage occurs at the vent terminal due to snow, ice, leaves, spider webs or other type of obstructions, the unit will stop working. The unit will not function until the blockage has been removed. If the unit then fails to operate, contact a qualified service agency.
23. For a manufactured home (USA only) or mobile home OEM or residential installation, this unit has been designed and certified to be converted from natural gas to propane or vice-versa. When provisions are being made to convert this unit, a certified conversion kit must be used. You must also readjust manifold gas pressure to specifications indicated in the conversion manual. If in doubt, contact Rinnai America for assistance.
24. Clothing or other flammable material should not be placed on or near the appliance.

DIMENSIONS

FLUE MANIFOLD POSITION IMPORTANT

Before drilling the flue hole, check for water and gas pipes as well as electric cables. Use a 3 1/8" (80mm) drill for hole through the wall. Center of hole must be located exactly at specified point. See diagram. For weatherboard walls, drill through center of weatherboard from outside. Then drill from inside through plasterboard.

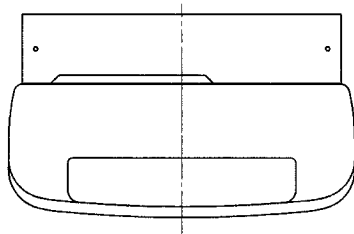
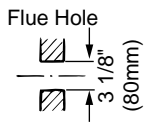

inches (mm)

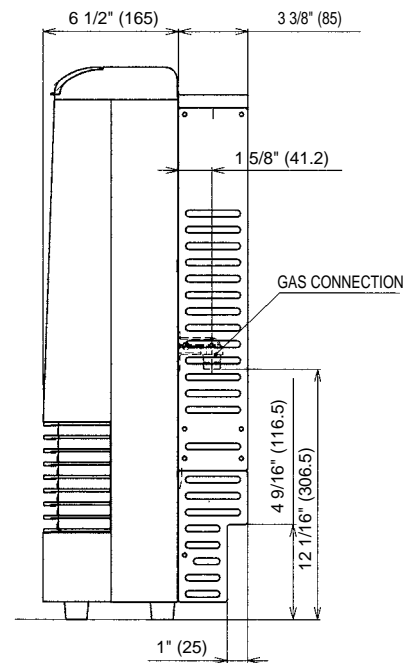
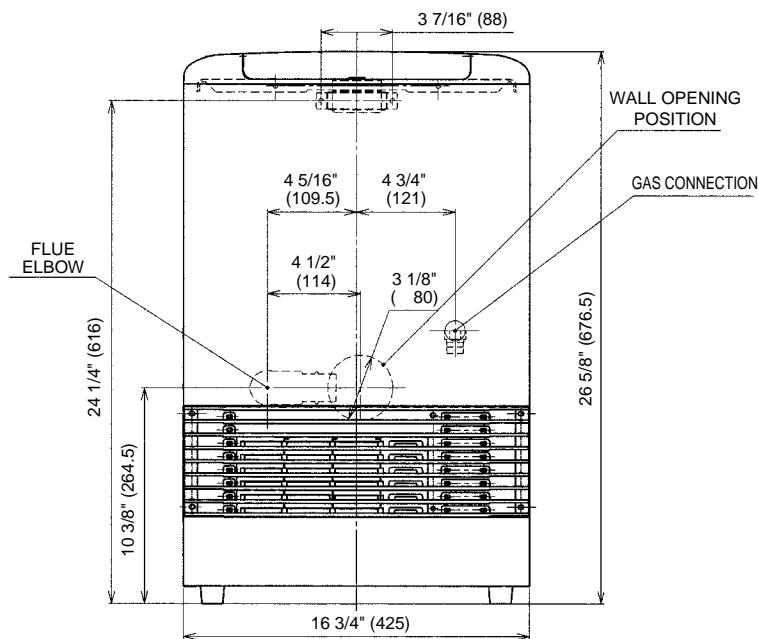
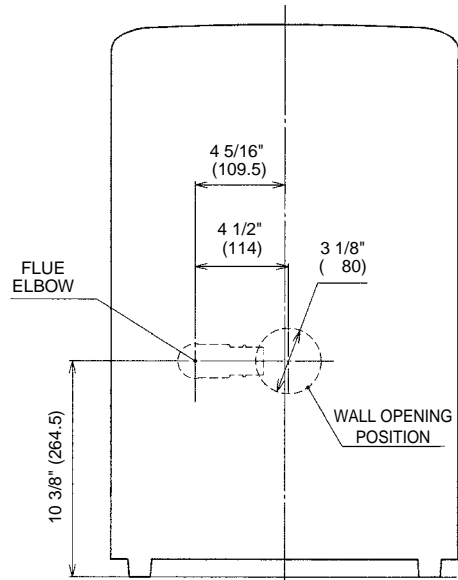

SPECIFICATIONS

MODEL #	BTU/h		MIN. CLEARANCES			FAN CFM OUTPUT
	INPUT	OUTPUT	SIDE	TOP	FRONT	
RHFE-263FA-N NATURAL	Low 5,500 High 11,000	Low 4,450 High 8,800	2" (50mm)	10" (250mm)	40" (1m)	LO:96.4 HI:128.5
RHFE-263FA-P PROPANE	Low 5,700 High 11,000	Low 4,600 High 8,800	2" (50mm)	10" (250mm)	40" (1m)	LO:96.4 HI:128.5

SPECIFICATIONS

Type of Appliance	Fan forced flued gas furnace
Model	RHFE-263FA ENERGYSAVER
Dimensions	Width - 16 3/4" (425mm) Depth - 9 13/16" with back spacer (250mm with back spacer) Height - 26 5/8" (676.5mm)
Weight	Approx. 37 lbs.
Connections	Electrical - AC 120V 60Hz 47 watts Gas - 1/2" female NPT
Combustion System	Stainless steel bunsen burner
Ignition System	Continuous spark
Operation	Finger touch control buttons
Temperature Control	Electronic thermostat HI-LOW/OFF Up/down switch 2°F increments
Temperature Range	Modulates Continuous LOW = 55°F 60°F ~ 80°F HI = High Combustion
Warm Air Outlet	Bottom front louver
Indicator/Lamps	Operation/Combustion, Filter, SetTemp., RoomTemp., Economy, Function Lock.
Operating Buttons	ON/OFF, Up/down, Function-lock, Economy
Economy Mode	Energy saving feature
Humidifier Tray	Capacity - 1.5 pints (700cc)

Safety Devices	Flame failure – Flame rod Over heat – Bi-metal switch, thermal fuse, thermistor Power failure – PCB Power surge – 3 Amp. fuse Fan delay – Micro computer timer Pre-purge – Combustion fan, pre-purge timer, spark sensor Room over heat – Automatic cut off at 104°F after 10 minutes	
Noise Level Range	HI ~ LOW = 38 ~ 31dB	
TYPE	Combustion Method	Forced combustion
	Air Supply Exhaust	Closed Type
	Radiation Method	Forced convection
AIR SUPPLY/ EXHAUST PIPE	Wall Penetration Hole	3 1/8" (80mm)
	Max. Extended	13ft., 2 90°bends (4m, 2 90°bends)

SPECIFICATIONS FOR VENT SIZES		
S	3" - 4 1/2" (75 - 115)mm	Thin Walls Mobile Home
A	4 1/2" - 9 1/2" (115 - 240)mm	Wood Walls
B	9 1/2" - 15 3/4" (240 - 400)mm	Wood/Brick
C	15 3/4" - 23 5/8" (400 - 600)mm	Brick/Block
D	23 5/8" - 31 1/2" (600 - 800)mm	Special

** BTU - Efficiency increases with vent length. Clearances from combustibles (See page 3).

** Thermal efficiency rating determined under continuous operating conditions, and was determined independently of any installed system.

SAFETY POINTS

Do not restrict the warm air discharge by placing articles in front of the heater.

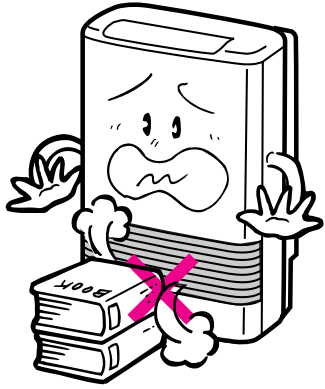

This appliance must not be used for any purpose other than heating.

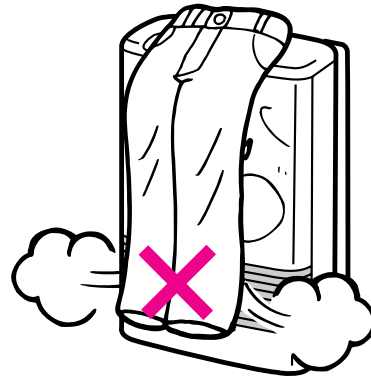

Do not spray aerosols while the heater is operating. Most aerosols contain butane gas, and can be a fire hazard if used near this heater when it is in use.



Do not install the heater in an unusually dusty area.



Do not allow curtains or other flammable or combustible materials to come into contact with the heater.



Combustible materials must not be placed where the heater could ignite them.

Do not allow anyone to sit on or lean against the appliance.



SAFETY POINTS

Keep flammable materials, trees, shrubs, etc., away from the flue terminal.

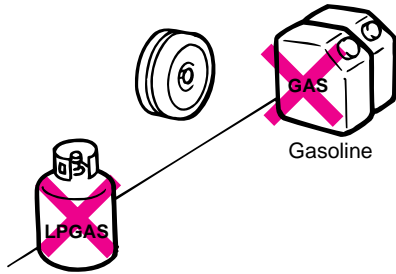

Do not allow anyone to poke articles through the louvers.

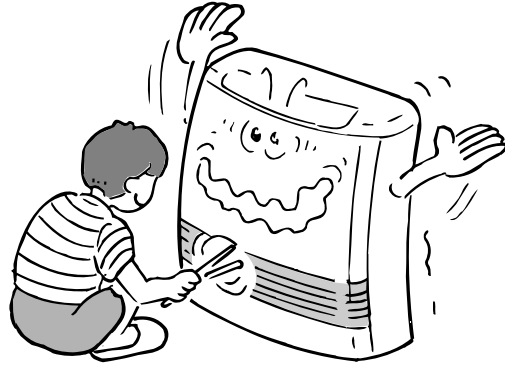

Filter should be cleaned at regular intervals. See page 29.

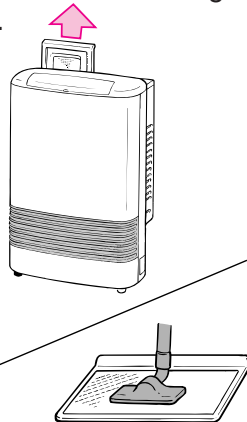

Clean as needed.

Young children should be supervised at all times. Hand or body contact with the louvers should be avoided.

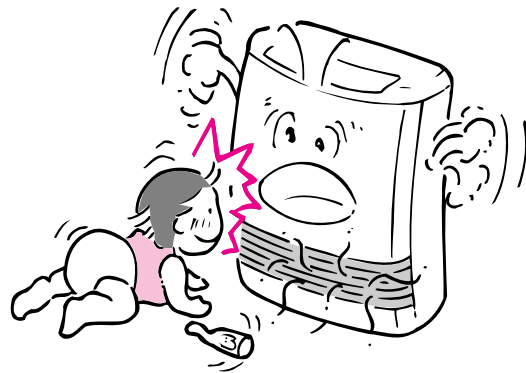

Do not place articles containing liquids on top of the heater. Liquid spilled on the controls may cause extensive damage.

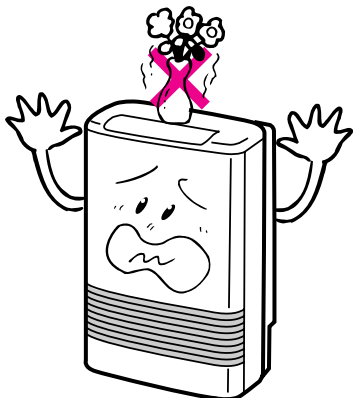

Do not allow young children or an infant to sleep directly in front of the heater.

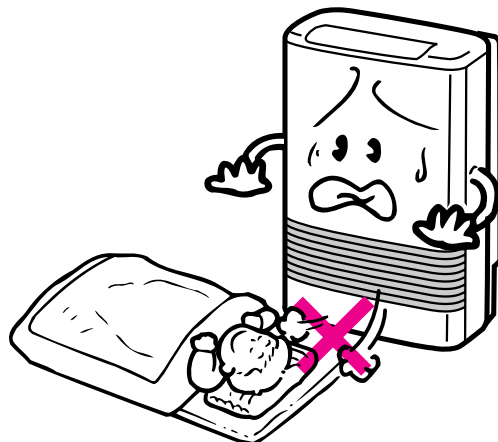

GETTING TO KNOW YOUR NEW RHFE-263FA

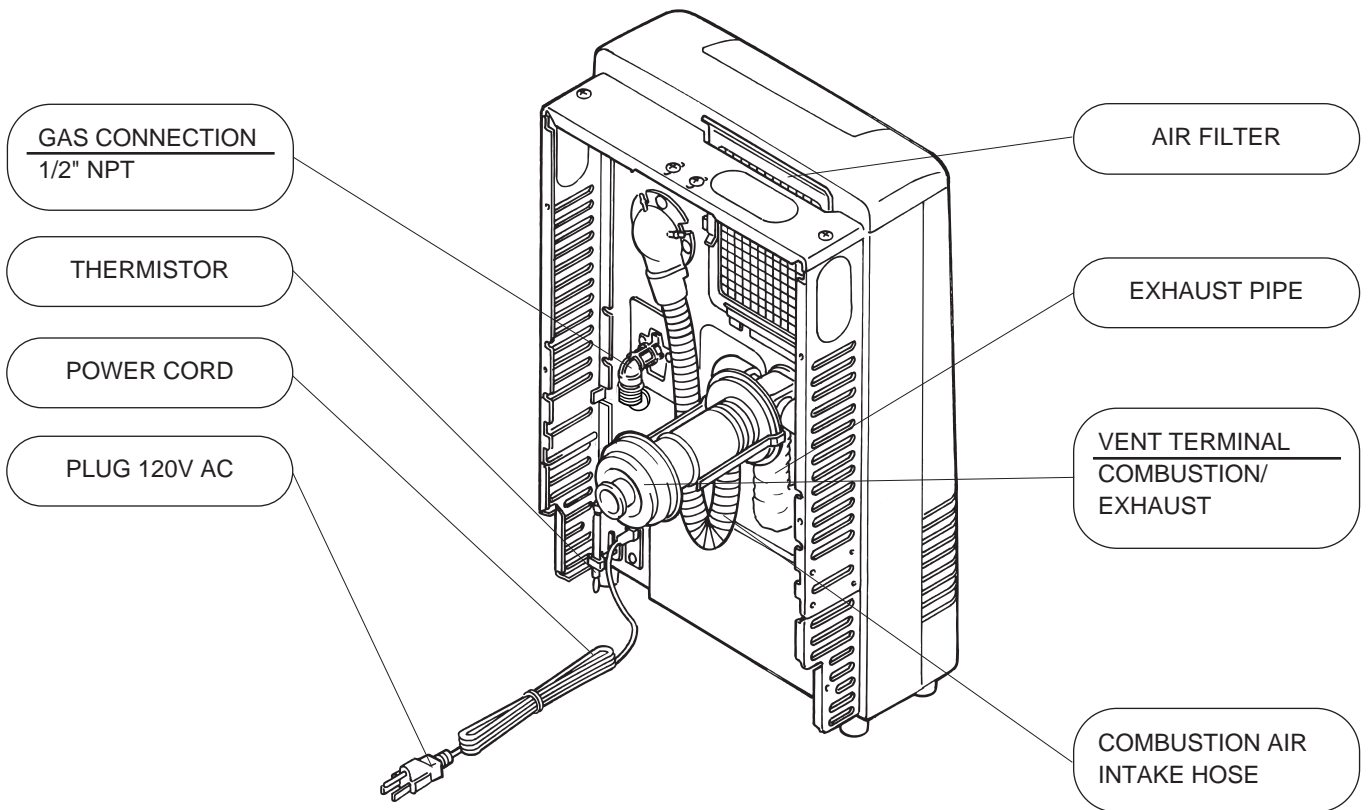
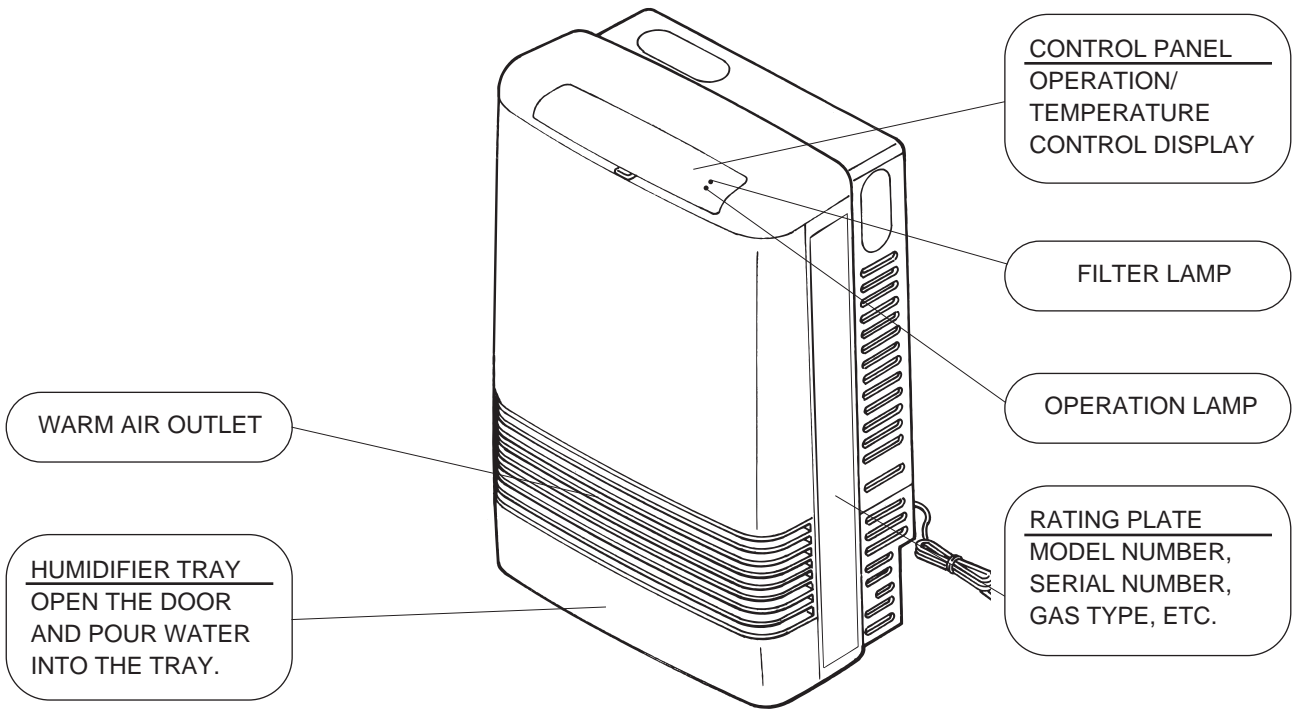

CONTROL PANEL

ALL BUTTONS BEEP WHEN OPERATED.

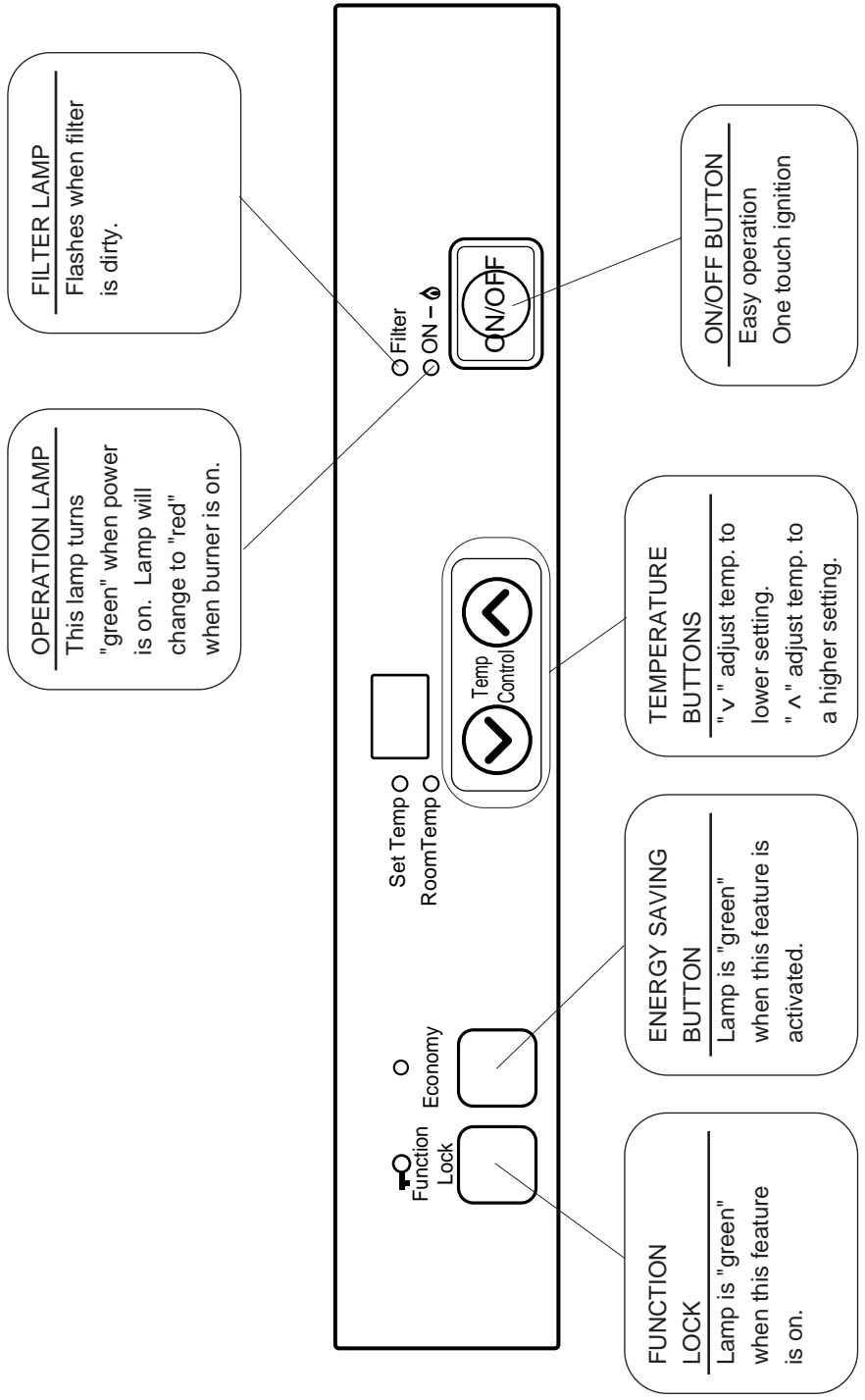

CUT-AWAY DIAGRAM

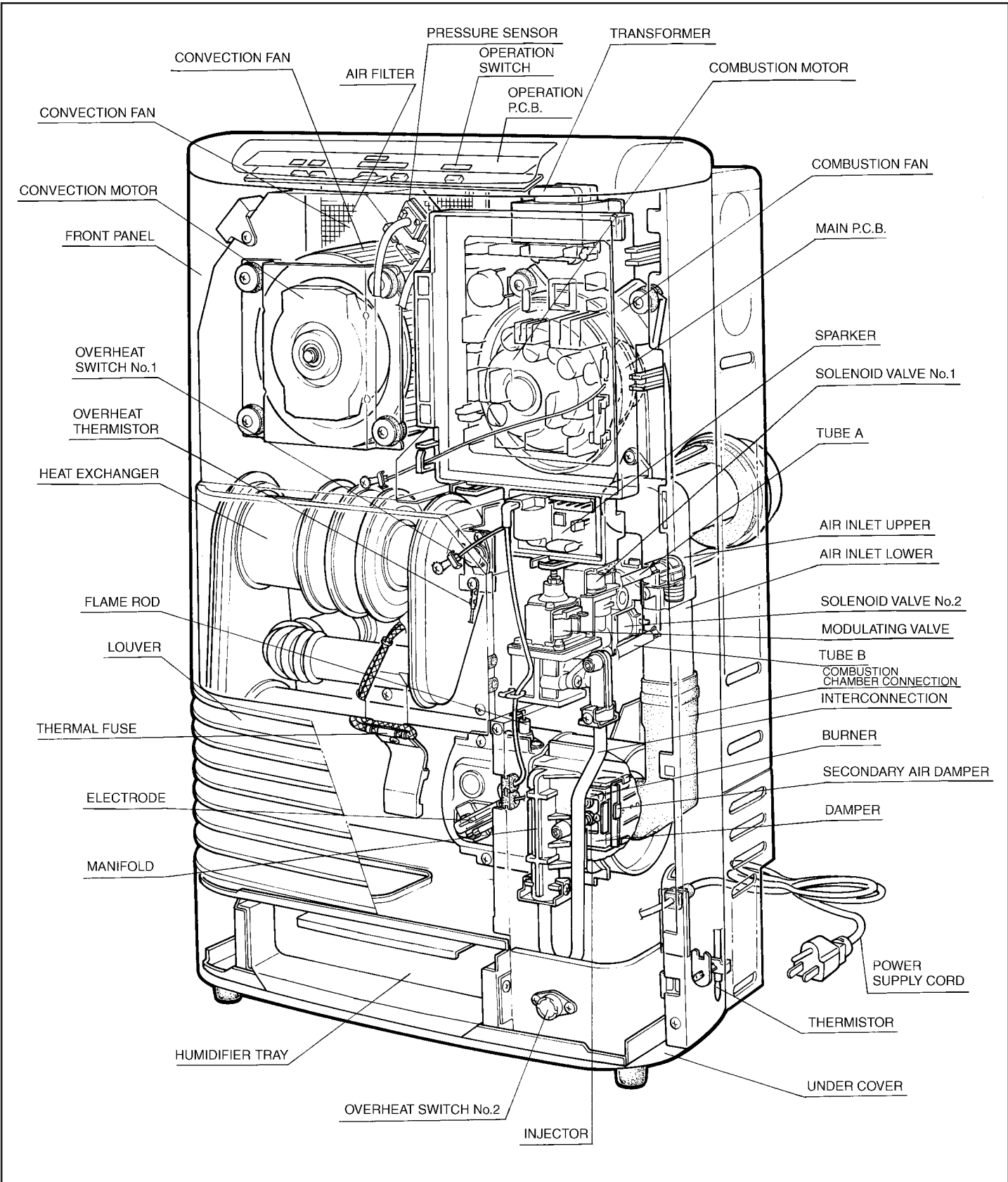

NOTICE BEFORE INSTALLATION

The heater must be installed by a qualified service person according to these installation instructions.

Check your local building codes for the proper method of installation. In the case of absence of local codes, this heater should be installed in accordance with the National Fuel Gas Code ANSI Z223.1.

Check local codes or, in the absence of local codes, the current CAN/CGA B149 INSTALLATION CODE.

DUE TO HIGH TEMPERATURES, THE APPLIANCE SHOULD BE LOCATED OUT OF TRAFFIC AND AWAY FROM FURNITURE AND DRAPERIES.

CHILDREN AND ADULTS SHOULD BE ALERTED TO THE HAZARDS OF HIGH SURFACE TEMPERATURES AND SHOULD STAY AWAY TO AVOID BURNS OR CLOTHING IGNITION.

“WARNING” Do not operate appliance with the panel(s) removed, cracked or broken. Replacement of the panel(s) should be done by a licensed or qualified service person.

INSTALLATION AND REPAIR SHOULD BE DONE BY A QUALIFIED SERVICE PERSON. THE APPLIANCE SHOULD BE INSPECTED BEFORE USE AND AT LEAST ANNUALLY BY A QUALIFIED SERVICE PERSON. MORE FREQUENT CLEANING MAY BE REQUIRED DUE TO EXCESSIVE LINT FROM CARPETING, BEDDING MATERIAL, ETC. IT IS IMPERATIVE THAT CONTROL COMPARTMENTS, BURNERS AND CIRCULATING AIR PASSAGEWAYS OF THE UNIT BE KEPT CLEAN.

The appliance, when installed, must be electrically grounded in accordance with local codes or, in the absence of local codes, with the National Electrical Code, ANSI/NFPA 70 or Canadian Electrical Code, CSA C22.1, if an external electrical source is utilized.

WARNING: THIS APPLIANCE IS EQUIPPED WITH A THREE-PRONG (GROUNDING) PLUG FOR YOUR PROTECTION AGAINST SHOCK HAZARD AND SHOULD BE PLUGGED DIRECTLY INTO A PROPERLY GROUNDED THREE-PRONG RECEPTACLE.











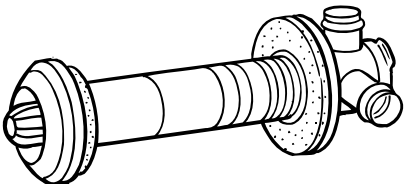

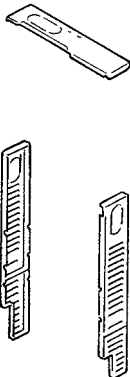
Do not cut or remove the grounding prong from the plug.

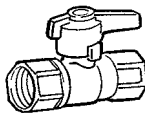
Rinnai recommends a dedicated electrical circuit. This gas appliance must not be connected to a chimney flue serving a separate solid-fuel burning appliance.

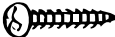
When the appliance is installed directly on carpeting, tile or other combustible material other than wood flooring, the appliance shall be installed on a metal or wood panel extending the full width and depth of the appliance.

Appliance input ratings are based on sea level operation and need not be changed for operation up to 2,000 feet elevation. For operation at elevations above 2,000 feet, manufactured to specified deration conditions for Canada and the United States.

INSTALLATION INSTRUCTIONS

Flue Manifold1		Spare rubber seal1 (‘A’ Flue units only)			
					
		(For weatherboard installations)			
Back Spacer Set		1	Spacer Bracket		1
			Pipe Stopper		1
			Manual Valve Set		1
			Screw	 (For Clamp)	2
Insulation Clip		1	Screw	 (For Wall Bracket and Flue manifold)	5
Plastic tie for air inlet		1	Screw	 (For Back Spacer)	10
Clamp		2	Screw	 (For Flue Manifold)	3
Wall Bracket		1	Owner's Manual Conversion Manual		1

Check to ensure gas type on rating plate matches gas being supplied to the unit. If not, unit may have been converted and should be checked to ensure conversion was done properly. If not, unit could be damaged due to being overfired.

Refer to local gas authority for confirmation of gas type if in doubt.

Refer to data plate located inside of the front panel.

Check for damage. If the unit is damaged, contact your supplier or Rinnai.

Do not install a damaged unit before checking with your supplier.

Refer to an approved pipe sizing chart if in doubt about size of gas line.

GAS CONNECTION

1. The gas supply line shall be gas-tight, sized and so installed as to provide a supply of gas sufficient to meet the maximum demand of the heater without loss of pressure.
2. A shut off valve (and appliance connector valve) should be installed in the upstream of the gas line to permit servicing.
3. Flexible pipe and any appliance connector valve used for gas piping shall be types approved by nationally recognized agencies.
4. Any compound used on the threaded joint of the gas piping shall be a type which resists the action of liquefied petroleum gas.
5. Supplied gas pressure must be within the limits shown in the specifications.
6. After completion of gas pipe connections, all joints including the heater must be checked for gas tightness by means of leak detector solution, soap and water, or an equivalent nonflammable solution, as applicable.

CAUTION: Since some leak test solutions, including soap and water, may cause corrosion or stress cracking, the piping shall be rinsed with water after testing, unless it has been determined that the leak test solution is noncorrosive.

7. The appliance and its appliance main gas valve must be disconnected from the gas supply piping system during any pressure testing of that system at test pressures in excess of 1/2 P.S.I (3.5kPa).

The appliance must be isolated from the gas supply piping system by closing its individual manual shut off valve during any pressure testing of the gas supply system at test pressures equal to or less than 1/2 psig.

8. Two 1/8" test plugs are provided for testing of manifold differential pressure. See schematic for location. (On page 40, item # 126)

At time of installation, installer must supply a 1/8" N.P.T. plugged tapping, accessible for test manometer connection, immediately up stream of the gas supply connection to the appliance.

9. Notice to installer: Install manual gas cut-off valve so that it can be accessed for easy operation. Do not conceal manual cut-off valve behind back spacer. See diagram.

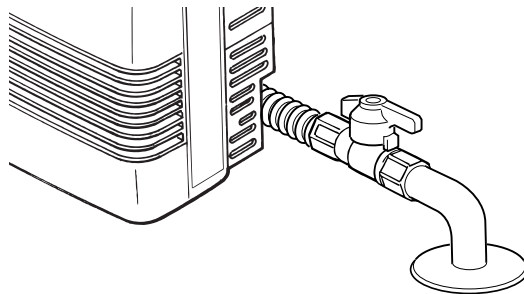

CANADIAN VENT REGULATIONS

CAN/CGA-B149.1-M91

A vent shall not terminate:

- (a) Directly above a paved sidewalk or paved driveway which is located between two single family dwellings and serves both dwellings;
- (b) less than 7 ft. (2.13m) above a paved sidewalk or a paved driveway located on public property;
- (c) within 6 ft. (1.8m) of a mechanical air supply inlet to any building;
- (d) above a meter/regulator assembly within 3 ft. (900mm) horizontally of the vertical centerline of the regulator;
- (e) within 6 ft. (1.8m) of any gas service regulator vent outlet;
- (f) less than 1 ft. (300mm) above grade level;
- (g) within the following distances of a window or door which can be opened in any building, any non-mechanical air supply inlet to any building or the combustion air inlet of any other appliance;
 - (i) 1 ft (300mm) for inputs up to and including 100,000 Btuh (30kW),
 - (ii) 3 ft (900mm) for inputs exceeding 100,000 Btuh (30kW); and
- (h) underneath a veranda, porch or deck, unless
 - (i) the veranda, porch or deck is fully open on a minimum of two sides beneath the floor, and
 - (ii) the distance between the top of the vent termination and the underside of the veranda, porch or deck is greater than 1 ft. (300mm).

FOR COMPLIANCE TO NFPA 54 OR Z223.1 U.S.A.

Vent terminal must be located at least 3 feet above any forced air inlet location within 10 feet away.

Vent terminal must not be located over public walk ways or be detrimental to regulators and equipment where condensate could be a problem.

Vent terminal must be kept clear of snow at all times.

The bottom of the vent terminal and the air intake must be located at least 12 inches above grade.

The vent terminal of a direct vent appliance with an input of 50,000 Btu per hour or less shall be located at least 9 inches from any opening through which flue gases could enter a building, and such an appliance with an input over 50,000 Btu per hour shall require a 12 inch vent termination clearance. The bottom of the vent terminal and the air intake shall be located at least 12 inches above grade.

LOCATION / CLEARANCES

When positioning the heater, the main points governing the location are:

1. Flueing
2. Warm air distribution

This heater is not designed to be built in.

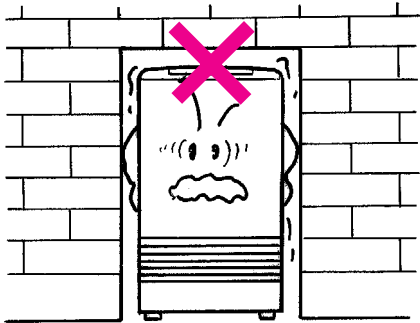

The flue terminal should be positioned away from flammable materials.

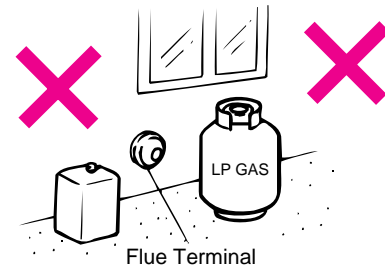

Do not flue into natural draught flues or fireplaces. This unit can only be used with one of the five types of Rinnai flue kits. Do not flue unit into other rooms. Flue terminal must be outside.

The flue is not designed to be positioned under floors, or below the level of the heater.

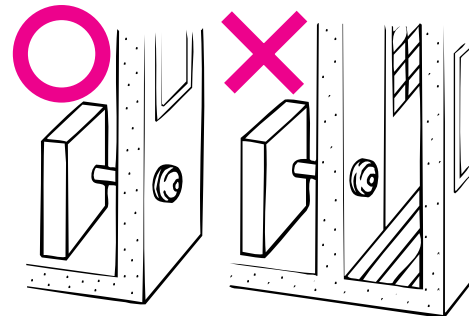
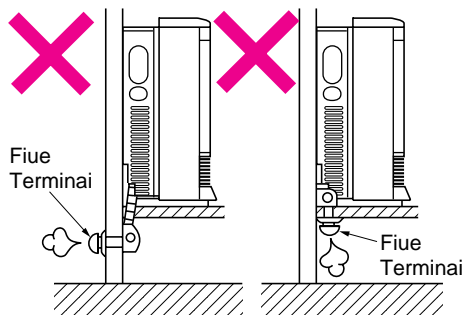

Flue may be positioned directly under opening windows, with a minimum clearance of 9" (230mm).

FLUE SIZES:

5 Flue lengths are available.

- S flue walls 3" ~ 4 1/2" (75 ~ 115mm)
- A flue walls 4 1/2" ~ 9 1/2" (115 ~ 240mm)
- B flue walls 9 1/2" ~ 15 3/4" (240 ~ 400mm)
- C flue walls 15 3/4" ~ 23 5/8" (400 ~ 600mm)
- D flue walls 23 5/8" ~ 31 1/2" (600 ~ 800mm)

SNOW AREAS

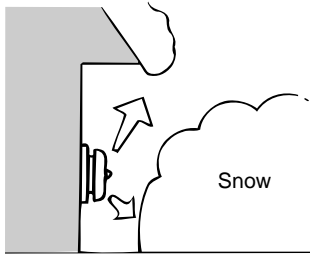

In areas subject to heavy snowfall, keep snow clear of flue terminal at all times.

STANDARD INSTALLATION OF FLUE MANIFOLD.

Diagram below shows minimum clearances and distances from obstructions. Also check local regulations.

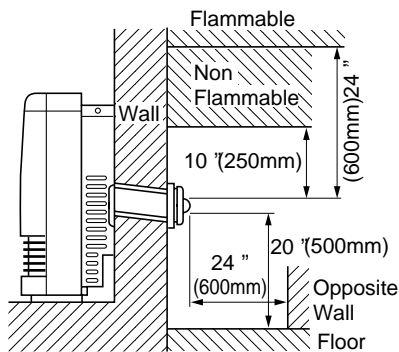

Side Clearances

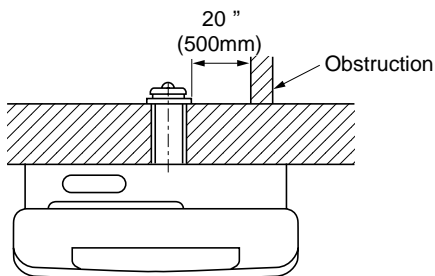

SLEEVE AND MANIFOLD INSTALLATION

METHOD FOR STANDARD WALLS

1. Disassemble Manifold from Sleeve.

The flue consists of 3 parts, sleeve, inside connectors and tube, outside terminal; (disassembly by pulling hard on outside terminal and inner connections, then pull sleeve off outer terminal.)

NOTE: Clearance to combustibles for terminal assembly sleeve and flanges is 0".

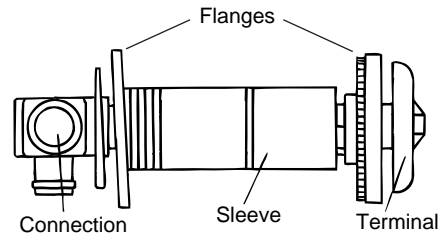

2. Adjustment of Sleeve Length.

Measure wall thickness through previously drilled 3 1/8" (80mm) hole.

End of sleeve should protrude 3/16" ~ 3/8" (5 ~ 10mm) from outside wall. Adjust sleeve length to wall thickness plus 3/16" ~ 3/8" (5 ~ 10mm). (Sleeve is threaded for adjustment.) Do not extend beyond red line.

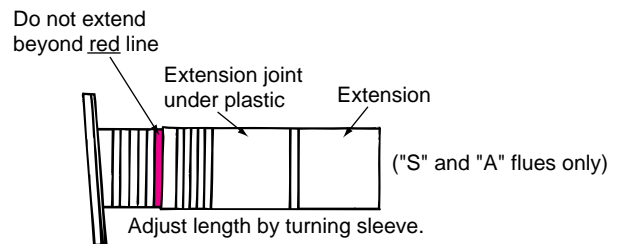

3. For S and A flue only.

Depending on flue set and wall thickness extension piece "C" may need to be removed. Cut plastic, remove extension, then follow instruction 2. This applies to "S" and "A" flues only. There is no extension on other flues, they can be fully adjusted by turning the threaded section.

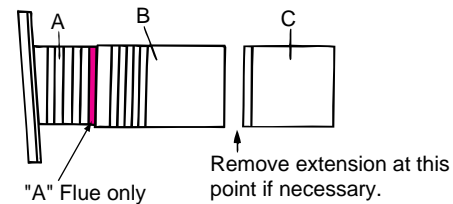

4. Fixing Sleeve.

Fix to the wall, using the 3 screws provided.

NOTE: The flange is marked "TOP", sleeve must be fitted with this mark **Up**. Check sleeve protrudes 3/16" ~ 3/8" (5 ~ 10mm) on the outside.

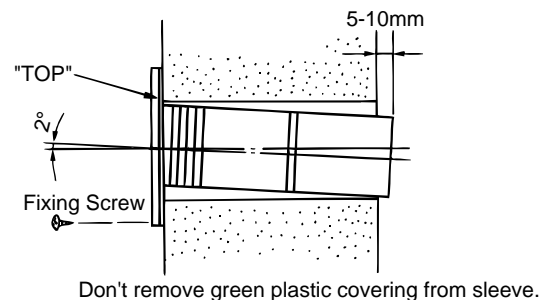

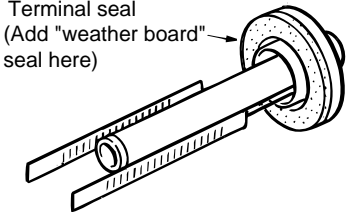
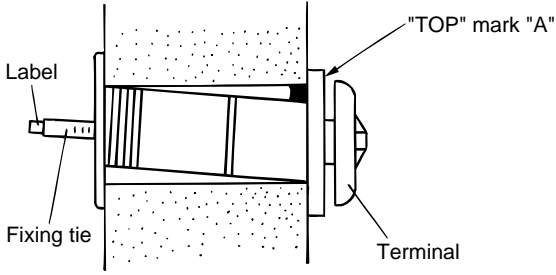
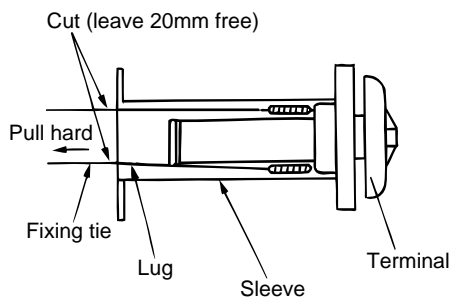
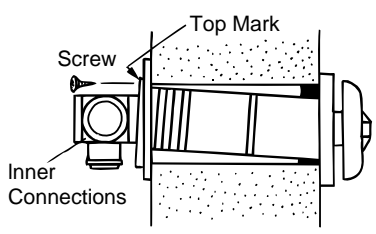
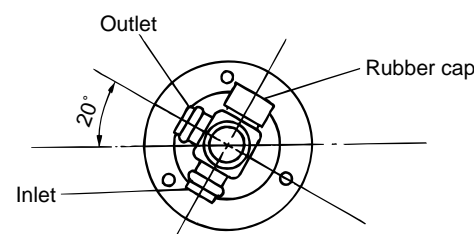
<p>5. Check rubber seal is in place on terminal.</p> <p>*For weather board walls, add spare rubber seal provided to compensate for weather board angle.</p>	
<p>6. Installation of Terminal</p> <p>From outside, insert terminal into sleeve with the “A” mark at the top. Left hand side fixing tie is marked “LEFT” (from inside).</p>	
<p>7. Attached Ties</p> <p>Pull hard on left and right hand side ties. Clip ties over lugs inside sleeve. You should be able to pull ties 2 or 3 slots past the starting point. Cut the ties, leaving about 3/4" (20mm) past the lugs. Bend ties so they are parallel with the wall.</p>	
<p>8. Insert Inner Connection Assembly.</p> <p>Push assembly into the terminal tube. Make sure “TOP” mark is uppermost. Fix with 3 screws provided.</p>	
<p>9. Manifold can still be turned after attaching.</p>	

FITTING UNIT

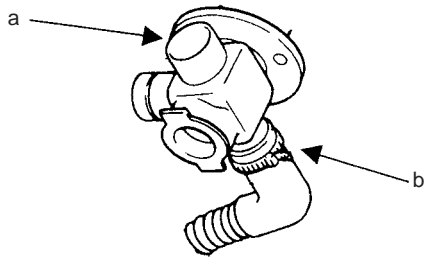

Attach the Air Inlet Hose to the flue manifold on either inlet position a or b. The unused inlet is plugged with the rubber cap supplied on the manifold.

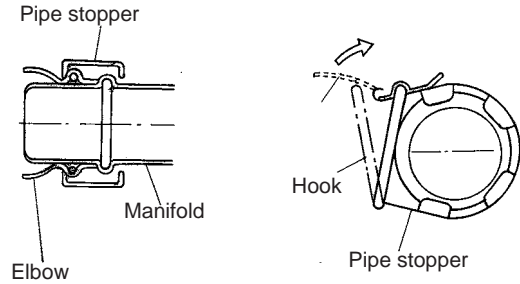

Fit the Pipe stopper over the connection between the flue elbow and the manifold. Engage the hook and rotate it until it snaps against the body of the clamp.

The following components can be fitted by reaching down the rear of the appliance as it is positioned against the wall.

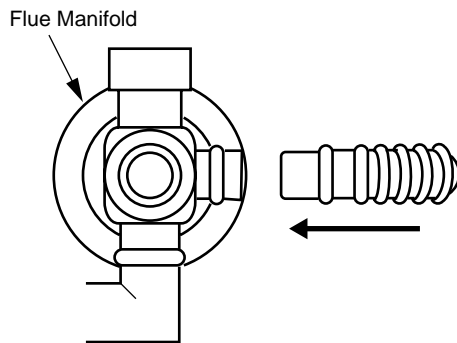
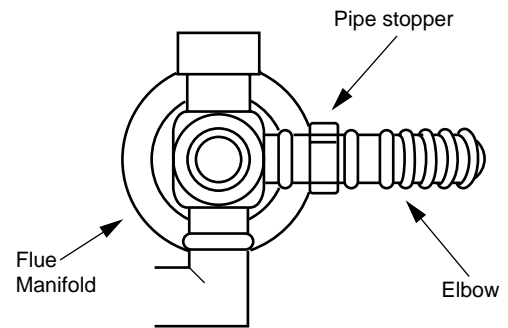

Connect the flue elbow to the manifold by moving the appliance into position.

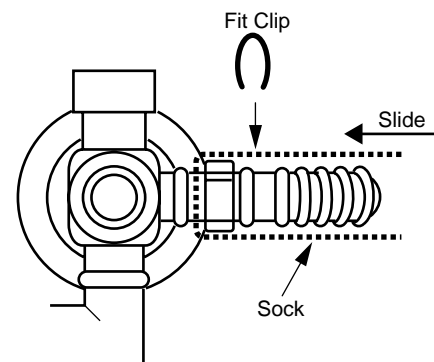

Slide the insulation sleeve up to the flue manifold and slip the securing clip over the sleeve as shown.

5. Tighten all screws.

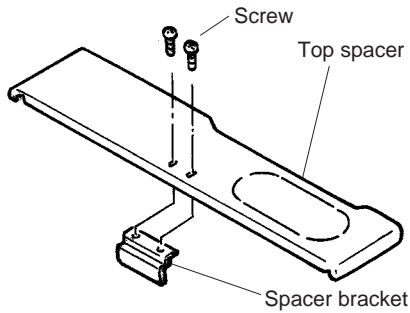

SECURE HEATER TO WALL

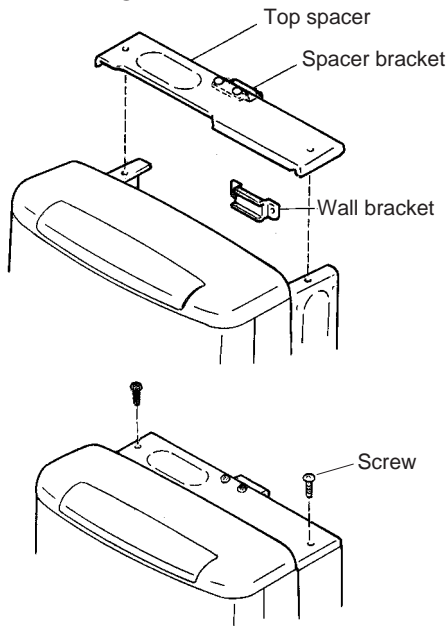

Replace top spacer, clipping the spacer into the wall brackets at the same time as attaching it to the heater. Secure top spacer with the screws provided. THE HEATER IS NOW SECURED TO THE WALL.

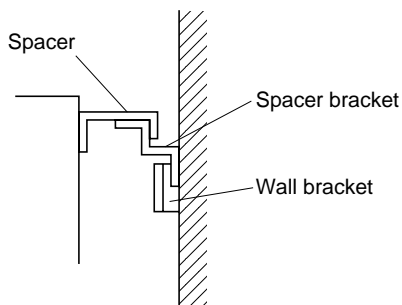

Replace fan filter.

INSTRUCT CUSTOMER ON USE OF HEATER

When you are satisfied that the appliance is operating correctly, explain operation of heater to the customer.

Fault-Failure Procedure

If unable to get the heater to operate correctly, contact Rinnai directly or your Agent or Gas Utility.

Do not use electrical extension cords to connect unit to power supply. Keep the power cord away from the flue.

Some items are not covered under the unit's warranty. Example: annual maintenance, carbon on flame rods/igniter, dust, spider webs, improper conversions, etc.

OPERATING INSTRUCTION LABEL ENERGYSAVER RHFE-263FA

FOR YOUR SAFETY READ BEFORE OPERATING

WARNING: If you do not follow these instructions exactly, a fire or explosion may result causing property damage, personal injury or loss of life.

- A. This appliance does not have a pilot. It is equipped with an ignition device which automatically lights the burner. Do not try to light the burner by hand.
- B. BEFORE OPERATING, smell all around the appliance area for gas. Be sure to smell next to the floor because some gas is heavier than air and will settle on the floor.
- WHAT TO DO IF YOU SMELL GAS
- Do not try to light any appliance.
 - Do not touch any electric switch; do not use any phone in your building.
 - Immediately call your gas supplier from a neighbor's phone. Follow the gas supplier's instructions.
- If you cannot reach your gas supplier, call the fire department.
- C. Use only your hand to push in or turn the gas control knob. Never use tools. If the knob will not push in or turn by hand, don't try to repair it. Call a qualified service technician. Force or attempted repair may result in a fire or explosion.
- D. Do not use this appliance if any part has been under water. Immediately call a qualified service technician to inspect the appliance and to replace any part of the control system and any gas control which has been under water.

OPERATING INSTRUCTIONS

- STOP! Read the safety information above on this label.
1. Set the thermostat to lowest setting.
 2. Turn off all electric power to the appliance via the ON/OFF button on the control panel. Locate manual gas valve to be found on back side of heater.
 3. Turn Manual valve clockwise  to the full OFF position.
 4. Wait five (5) minutes to clear out any gas. Then smell for gas, including near the floor. If you then smell gas,
5. Turn Manual gas valve to the full ON position.
 6. Turn on all electric power to the appliance via ON/OFF button.
 7. Set the thermostat to desired setting.
 8. Burner is lit when indicator lamp "ON" turns red.
 9. "ON" indicator flashes when burner fails to ignite.
 10. If the appliance will not operate, follow the instruction "TO turn off gas to appliance" and call your service technician or gas supplier. See manual for additional information.

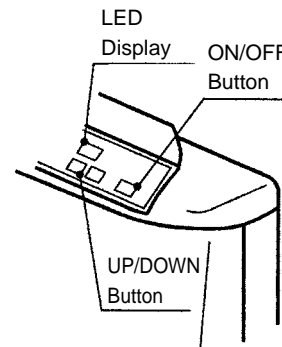
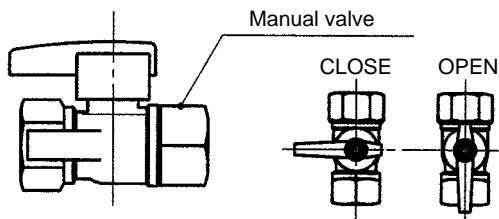

TO TURN OFF GAS TO APPLIANCE

1. Turn off electric power to the appliance using the ON/OFF button located on the control panel.
2. Locate manual valve to be found upstream on gas line from the unit.
3. Turn manual valve clockwise to the full OFF position.

NOTE: The fan will continue to operate until the appliance is cool. Do not turn the appliance off by unplugging it from the wall.

Keep burner and control compartment clean. Refer to the installation and operating instructions accompanying heater.

ADDITIONAL CUSTOMER OPERATING INFORMATION

IGNITION

Make certain the heater is connected into both the gas and the electric power.

Depress the ignition ON/OFF button slowly and firmly.

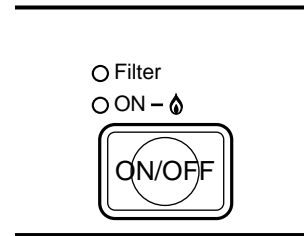

When you release the ignition ON/OFF button, the 'LED Display will illuminate, the spark will ignite the main burner and the Combustion fan will begin to run. If the heater does not ignite within 15 seconds, the spark will stop and the 'LED Display will show Error Code. Turn off unit and repeat ignition operation.

TEMPERATURE LEVEL

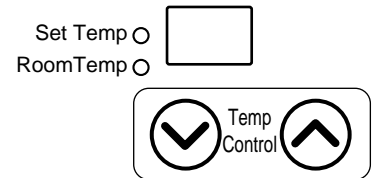

This heater has an automatic ignition system. When the main burner has lit, the combustion lamp will glow red, and the spark will stop. There may be a smell of burning dust or oil the first time the heater is lit or when the heater has been out of operation for a long time. This is normal. You may need to repeat the ignition operation the first time the heater is plugged in, due to air in the gas line.

COMBUSTION INDICATOR

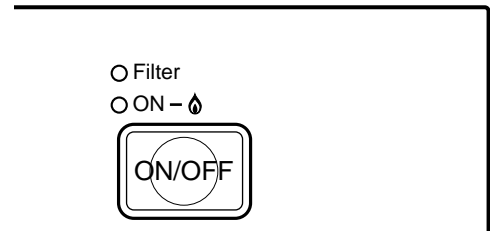

TEMPERATURE CONTROL

The thermostat automatically modulates the burner and the fan to maintain the room temperature which you have selected.

To change the room temperature, simply adjust the temperature control buttons until the desired setting is indicated.

The temperature range from LO to HI is about 55°F (12°C) to 97°F (36°C). Temperature control may be affected by the location of the heater.

ROOM TEMPERATURE DISPLAY

Temperature is indicated by the L.E.D. display on the control panel. The first time when the appliance is turned on, the preset temperature 72 F degrees (from the factory) will be shown on the L.E.D. display. Every time the Set Temp has been changed that set temperature will be the latest data appearing on the L.E.D. display the next time the appliance is turned on. To get to Set Temp press either ' up ' or ' down ' button. At the Set Temp, press ' up ' to increase the temperature or ' down ' to decrease. When the desired temperature is set, 10 seconds later the LED display will change to the room temperature mode which will show the current room temperature.

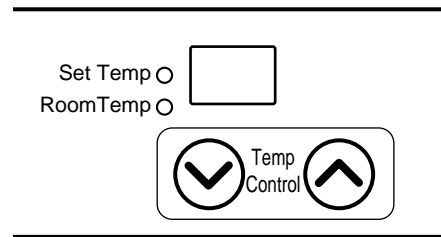

TO TURN UNIT OFF

Depress ignition ON/OFF button again.
The appliance will stop operating.
Do not turn off by unplugging at the power outlet.
Convection fan continues to run until heater is cool.

IGNITION BUTTON



ECONOMY BUTTON

To select 'Economy Mode', push the 'Economy' button, and the green lamp will glow. 30 minutes after the room temperature reaches the preset temperature (set by the thermostat), the 'Economy Mode' if set, reduces the temperature by 2°F. After another 30 minutes, it reduces the temperature by a further 2°F. This is an energy saving feature. It does not operate if the heater is under capacity for the room size.

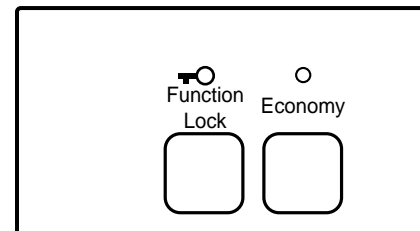

FILTER LAMP

If the filter lamp glows during operation, check air filter for dust. If there is dust present, clean filter. See section on care of heater. Turn heater off before cleaning filters.

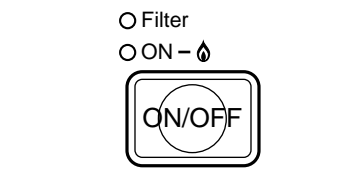

FUNCTION LOCK

OPERATING PRECAUTIONS

Please read this section carefully before using your Forced flue heater.

Gas Type, Power Source, and Manufactured Date

- Type of gas, power source and manufactured date are displayed on the nameplate placed on the right side of the unit.
 - Do not use gas other than the type of gas (gas group) indicated on the nameplate.
 - This equipment is for 120 V AC (60Hz) only. Do not use power source other than what is listed.

Caution

- Should the type of gas or power source be different, please contact your dealer. Using a different type of gas or power source may affect the performance or may be dangerous.
- If you are moving to another area, please check the types of gas and power source provided in the area. If the types of gas and power source are different, adjustment or modification is necessary. Please consult the gas provider in the new area.

Usage

- Do not use for drying clothes!
 - Do not use for any other purposes other than heating (e.g., drying the laundry).
 - Draping clothes over the unit blocks the warm air outlet or the filter area and is very dangerous, as it causes heat to build up inside the unit.

Usage Location

- Do not use near flammable material !!!

Place the unit sufficiently away from flammable objects such as furniture, wall and curtains. Check carefully when installing the unit.

REQUIRED DISTANCE FROM FLAMMABLES:

Top: At least 10" (250mm) Right: At least 2" (50mm)
Left: At least 2" (50mm)
Front: At least 40" (1m)

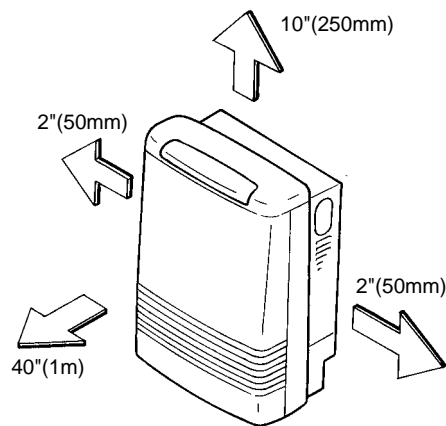

- Watch for falling objects !!!
Do not place under a shelf or in other locations where there is a danger of an object falling on the unit.
- Avoid using in special purpose rooms !!!
This equipment is made for use as a heater for a residential building. Do not use in beauty salons, factories and other places where spray or chemicals are used or where a large amount of dust is present.

Do not use hair treatment products containing silicon in a room heated by the Forced flue heater, as they may cause ignition error, flame extinction or other malfunctions.

- Insert a board under the unit when placing on carpeted floor !!!
This heater may be installed on combustible flooring. When the heater is installed directly on carpeting, tile or other combustible material other than wood flooring, the heater shall be installed on a metal or wood panel extending the full width and depth of the heater.

Emergency Procedures:

Stay calm and turn the unit off !!!

In case of an emergency (e.g., abnormal overheating of the unit, loud noise), always stay calm, turn the unit off by pushing the ON/OFF button, close the gas valve and contact your dealer or the Rinnai office or store near you.

During a Thunderstorm:

When a thunderstorm is approaching, turn the unit off and unplug the power cord. Heavy thunderstorms may cause damage to the unit.

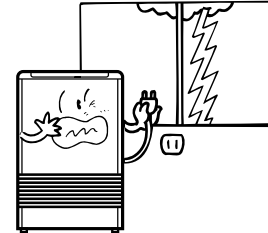

Inspection and Maintenance:

- Be sure to perform inspection and maintenance procedures. (See page 29 and 34 for details.) In particular, check the gas connection, power connection and air supply/exhaust pipe connection.
- Do not use the unit if you suspect malfunctioning or damage. Incomplete repairs are dangerous. In case of malfunctioning, read the instructions on page 32 and/or contact your dealer or the nearest Rinnai office.

During Snow Accumulation:

If the air supply/exhaust vent is covered by snow or damaged by falling icicles, the exhaust may be blocked and cause malfunctioning of the unit. Keep the area around the air supply/exhaust vent free of snow and icicles. Minimum clearance from snow accumulations should be at least (24").

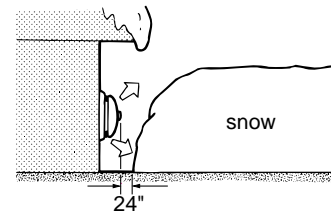

Installation of Unit:

- Please ask your dealer to install the unit properly in a safe location.
- Refer to the installation manual to make sure the unit is installed properly.

Customer's Operating Information:

The following pages explain how to use the Forced flue heater. Also read "Operating Precautions" on pages 23 - 26.

When Using for the First Time:

- Check the power cord and power plug.
 - Firmly plug the unit into an electrical outlet. Ensure outlet is properly grounded. An outlet that is not grounded properly can cause unit to operate erratically.
 - Make sure the power cord is not exposed to the heat from the exhaust pipe.
- Fully open the gas valve on the unit.

Before the Cold Season Begins:

- Check the air supply/exhaust connection.
- Before using this heater, inspect the air supply/exhaust connection to make sure the pipe is not disconnected or bent.
- Check the main unit and the air supply/exhaust.
- Make sure there is no combustible or flammable material near the main unit or the air supply/exhaust.

CAUTION:

If you find a problem with the air supply/exhaust, do not use the unit. Contact your dealer or the nearest Rinnai office.

Function Lock:

The Function lock feature prevents accidents due to tampering by small children.

- Press the "Function Lock" button.
The "Function Lock" lamp should come on and engage the function lock.
- Canceling the Function lock.
Press the "Function Lock" button again and hold for two (2) seconds.
This will disengage the function lock.

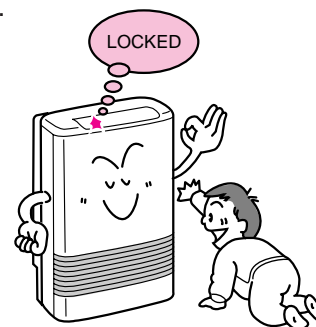

Note:

If the Function lock is engaged while the unit is operating, all operations by switches and buttons will be disabled except turning the unit off.

If the Function lock is engaged while the unit is off, all operation will be disabled. When you turn the unit on and the Function lock is engaged, you must cancel the Function lock before proceeding.

AIR FLOW CONTROL:

- The direction of air flow may be changed to the left or right.
Use a screwdriver or a similar object to change the direction of the vertical louver.

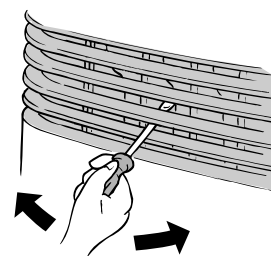
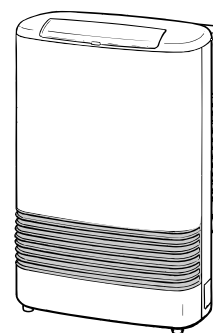

CAUTION:

- Do not adjust repeatedly (more than 5-6 times), as it may cause the louver to break.
- The horizontal louver (which determines the vertical air flow direction) is fixed and cannot be adjusted.
- Do not adjust the air flow direction while warm air is flowing, as it may cause burn injury.

Sensible Temperature Control:

The sensible temperature control feature enables comfortable heating which matches the conditions in the room.

- Based on the information collected by the room temperature thermistor when the heating starts, the heating capacity is automatically adjusted to achieve a comfortable heating effect and to reach the set room temperature quickly.

Adding Water to Humidifier:

Remove the bottom trim panel, below the louvers, by pulling on both sides. Simply pull the tray forward to allow it to be filled with water. The warm air will be humidified as it passes over the water in the tray. Refit the bottom trim panel after filling the tray. The RHFE-263FA is a very high efficiency appliance. During operation a small amount of condensation is produced in the flue system. This drains into the enamelled humidifier tray.

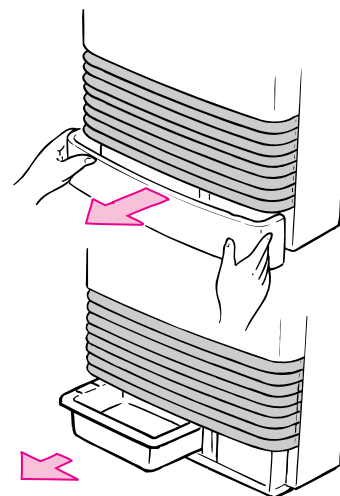

Caution:

- The humidifier tray and the surrounding area are hot when the unit is on. To avoid burns, do not add water to the tray while unit is on.
- Avoid adding water when the room is susceptible to condensation.
- If the water overflows from the water level hole when adding water, do not add any more water.

Care of Unit Exterior:

Dampen soft cloth with warm water, wring water out well and wipe the unit.

Caution:

Never use volatile substances such as benzine or thinners, as they cause fading of paint or deformation of resin.

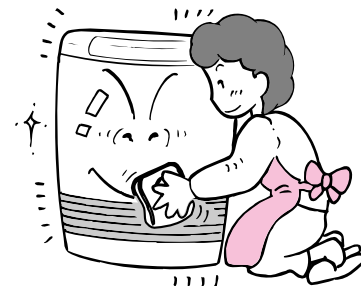

Care of Air Filter:

Always clean the air filter when the filter indicator lamp starts blinking.

- The filter indicator lamp starts blinking when the dust accumulates on the air filter. In this event, turn the unit off immediately, wait until the unit cools off and clean the filter.
- Even if the lamp is not blinking, if you think the filter is dirty, clean the filter while you are cleaning the room. This will ensure comfortable use.
- The air filter may be removed. Clean the filter with a vacuum cleaner or a duster.
- If the filter is greasy, wash quickly with detergent, shake water off and dry completely.
- After cleaning and drying, replace the filter securely.

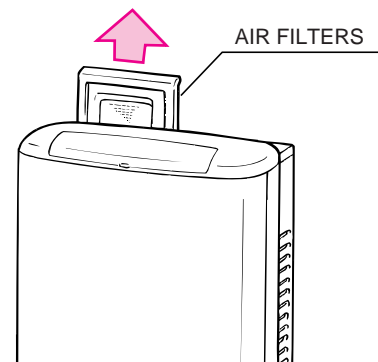

CAUTION:

- If you continue to use the heater with the filter indicator lamp flashing, the sensor may detect trouble and turn the unit off. This will cause the room temperature display lamp to code "14" and the "operation/combustion" lamp to flash, indicating that the safety device has been activated. In this event, clean the air filter immediately as instructed above.

TESTING

Testing Unit

Purge air from gas line.

Refer to pipe sizing chart if in doubt about the size of the gas line.

Connection can easily be reached from the top, rear of the unit. Check for leaks, using soapy water after turning gas on.

Plug unit in and turn power on, (CAUTION - 120V inside unit).

Turn thermostat to "HI", turn control to "ON". Unit should ignite within 10 seconds.

If unit does not ignite, there may be air in the gas line, turn control "OFF" then "ON" again.

Check pressure. Regulator is factory set.

If pressure is incorrect, check supply before altering regulator. The appliance must be stopped before testing unit.

Remove the 2 test point screws and connect the manometer hoses to the differential pressure test points on the modulating valve and burner manifold.

Turn the unit to "ON" position using the ON/OFF button on the operation panel and check pressure.

If pressures are correct, remove manometer and replace test point plug.

Leak test all gas connections.

WARNING: DO NOT OPERATE UNIT UNTIL PROPER INSTALLATION HAS BEEN COMPLETED.

CHECK

Fault-Failure Procedure

If unable to get the unit to operate correctly, contact Rinnai Agent, or Gas Utility. Please read the fault finding charts before reporting faults.

Do not use this heater if any part has been under water. Immediately call a qualified service technician to inspect the heater and to replace any part of the control system and any gas control which has been under water.

"WARNING" Do not operate appliance with the panel(s) removed, cracked or broken. Installation and repair should be done by a qualified service person. The appliance should be inspected before use and at least annually by a qualified service person.

More frequent cleaning may be required due to excessive lint from carpeting, bedding material, etc.. It is imperative that control compartments, burners and circulating air passageways of the appliance be kept clean. Ventilating system should be inspected and cleaned annually of all debris and spider webs.

Rinnai's service assistance telephone number is 1/800/621 - 9419.

PRE-SERVICE CHECK

Before asking for a service call, please check the following points.
These points are part of the normal operation of the unit.

■ At Ignition:

Heater does not operate.



Is the heater plugged in?
Have the fuses or breaker blown at the switch board?
Is there a power failure?
Is the air filter blocked?
Is anything blocking the outlet for the hot air?
Is the flue blocked?

Warm air does not flow when the burner lights.



The fan is started automatically after a short delay.
This is to allow the heat exchanger to warm up, helping to avoid cold draughts.

Smoke or strange smells are produced on the first trial light up after installation.



This is caused by grease or oil and dust on the heat exchanger and will stop after a short time.

Sharp clicking noises at ignition, or when unit cuts down on the thermostat, or goes out.



This is simply expansion noise from the heat exchanger.

■ During Combustion:

Clunking noise when the thermostat operates.



This is the sound of the solenoid gas valves opening and closing.

Unit is not heating room.



Is the air filter blocked?
Is the set temperature high enough?
Is the warm air outlet blocked by anything?
Are the doors and windows of the room closed?

Air filter is blocked or the louvers are blocked or obstructed.



Allow heater to cool, clean air filter, operate again.

Heater will not re-ignite after overheating.



Even after unit has cooled down, the heater does not ignite again. Repair is necessary.
Contact your local agent or Rinnai for a Service call.

■ When the unit is turned off.

Convection fan continues to run after turning OFF.



This is to remove the residual heat from the heat exchanger. The fan will stop when the heater cools down.

■ Other Points:

Steam is discharged from the flue terminal.



High efficiency appliances tend to discharge water vapor on cold days. This is normal.

Unit cuts off without apparent reason.



Check whether filters are blocked. Dirty filters will cause the heater to overheat.

Power Failure.



Switch OFF, then ON again when power is restored to re-set controls.

TROUBLE SHOOTING

Your RHFE-263FA requires very little maintenance. Simply clean the rear fan filter as needed and wipe the outer case and louver section with a damp cloth.

Cause \ Problem	No ON indicator	Burner doesn't ignite	Unusual combustion	Combustion stops during operation	Smell of gas	Noisy ignition	Takes too long to warm the room	Remedy
Not Plugged In	●	●						Plug In
Power Cut	●	●		●				Re-ignite manually after power is restored
(Initial Installation) Air In Gas Pipe		●						Purge air (Installer)
Gas Filter Blocked		●	●				●	Service Call
Miss Ignition	●	●						Service Call
Flue terminal obstructed			●	●		●		Clear obstruction
Flue manifold not connected						●		Service Call
Louver obstructed				●			●	Clear obstruction
Air filter blocked				●			●	Clean filter
Gas Escape					●			Service Call
Function Lock Set		●						Cancel Function Lock
Gas turned off at meter	●	●						Turn gas on

General maintenance items are not covered under unit's warranty. Such as cleaning dust, debris and carbon from flame rod, spider webs, and improper set up of unit.

ERROR MESSAGES

The Energysaver 263 has the ability to check its own operation continuously. If a fault occurs, an Error Message will flash on the Digital Display of the control panel. This assists with diagnosing the fault, and may enable you to overcome a problem without a service call. Please quote the code displayed when inquiring about service.

CODE DISPLAYED	FAULT	REMEDY
11	Ignition failure	Check gas is turned ON. Service call if repeated.
12	Flame failure	Check gas is turned ON. Service call if repeated.
14	Overheat	Clean filter Service call if repeated.
16	Room overheat	Lower room temperature to less than 40°C(104°F).
31	Room Temperature Sensor faulty	Service call.
32		
33	Overheat Temperature Sensor faulty	Service call.
34		
53	Sparker failure	Service call.
61	Combustion fan failure	Service call.
70	Faulty ON/OFF switch	Service call.
71	Faulty solenoids	Service call.
72	Faulty Flame Rod	Service call.
73	Communication Error	Turn heater OFF, then ON again.
49	Sensor breakdown	Service Call.
99	Flue block	Check around flue terminal

In all cases, you may be able to clear the Error Message simply by turning the heater OFF, then ON again. If the Error Message still remains or returns on the next operation, contact Rinnai or your nearest service agent and arrange for a service call.

MAINTENANCE / SERVICE

MAINTENANCE SUGGESTIONS

This heater has been designed and constructed for a long performance life when installed and operated properly under normal conditions. Regular inspections, as outlined in this section, are strongly recommended as means of keeping your heater operating efficiently throughout the season.

1. Cleaning

Heater must be cleaned annually. Keep heater clear of dust and debris especially in and around burner.

Cleaning procedures of heater are as follows:

- 1) Turn heater off. Allow to cool for one hour.
- 2) Remove the Front Panel by removing screws. See schematic on page 38.
- 3) Use pressurized air to remove dust from around main burner, heat exchangers and fan blades.
- 4) Use soft dry cloth to wipe cabinet.

DO NOT DAMAGE OR DISTORT ANY PARTS OF HEATER.

DO NOT USE WET CLOTH OR SPRAY CLEANERS ON BURNER.

2. Visual check of main burner flames.

Flame pattern should be as shown in the following Figures.

The burner must flame evenly over the entire surface when operating correctly. The flame must burn with a clear blue stable flame. See page 40 item #123 for location of view ports. Any and all parts removed for inspection or service must be replaced before operating unit.

3. The appliance area must be kept clear and free from combustible materials, gasoline and other flammable vapors and liquids.
4. The flow of combustion and ventilation air should not be obstructed.
5. Verify proper operation after servicing.

VISUAL CHECK

SATISFACTORY

FRONT VIEW

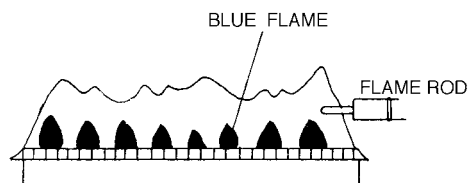

UNSATISFACTORY

FRONT VIEW

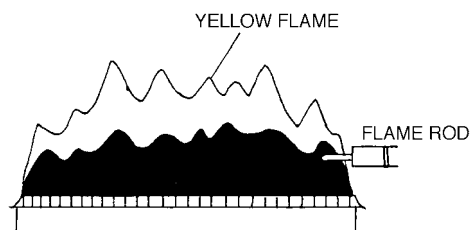

- VENT MAINTENANCE
- VENT SYSTEM
Must be checked annually for blockage or deterioration. See vent installation instructions for proper assembly.
- MAINTENANCE-ELECTRIC MOTORS
Motors are permanently lubricated and need no lubrication. Keep fan and motor free of dust and dirt. Clean annually.

CODE	COLOR
bk	black
bl	blue
gr	green
gr/y	green/yellow
r	red
w	white
y	yellow
gy	gray
or	orange

MARK	PARTS NAME
PS	PRESSURE SENSOR
FR	FLAME ROD
F	FUSE
TR	TRANSFORMER
SV1,2	SOLENOID VALVE 1,2
ER	ELECTRODE
SP	SPARKER
FM	CONVECTION FAN MOTOR
OHS1,2	OVERHEAT SWITCH1,2
TF	THERMAL FUSE
POV	MODULATING VALVE
BL	COMBUSTION FAN MOTOR
R.TH	THERMISTOR
OH.TH	OVERHEAT THERMISTOR

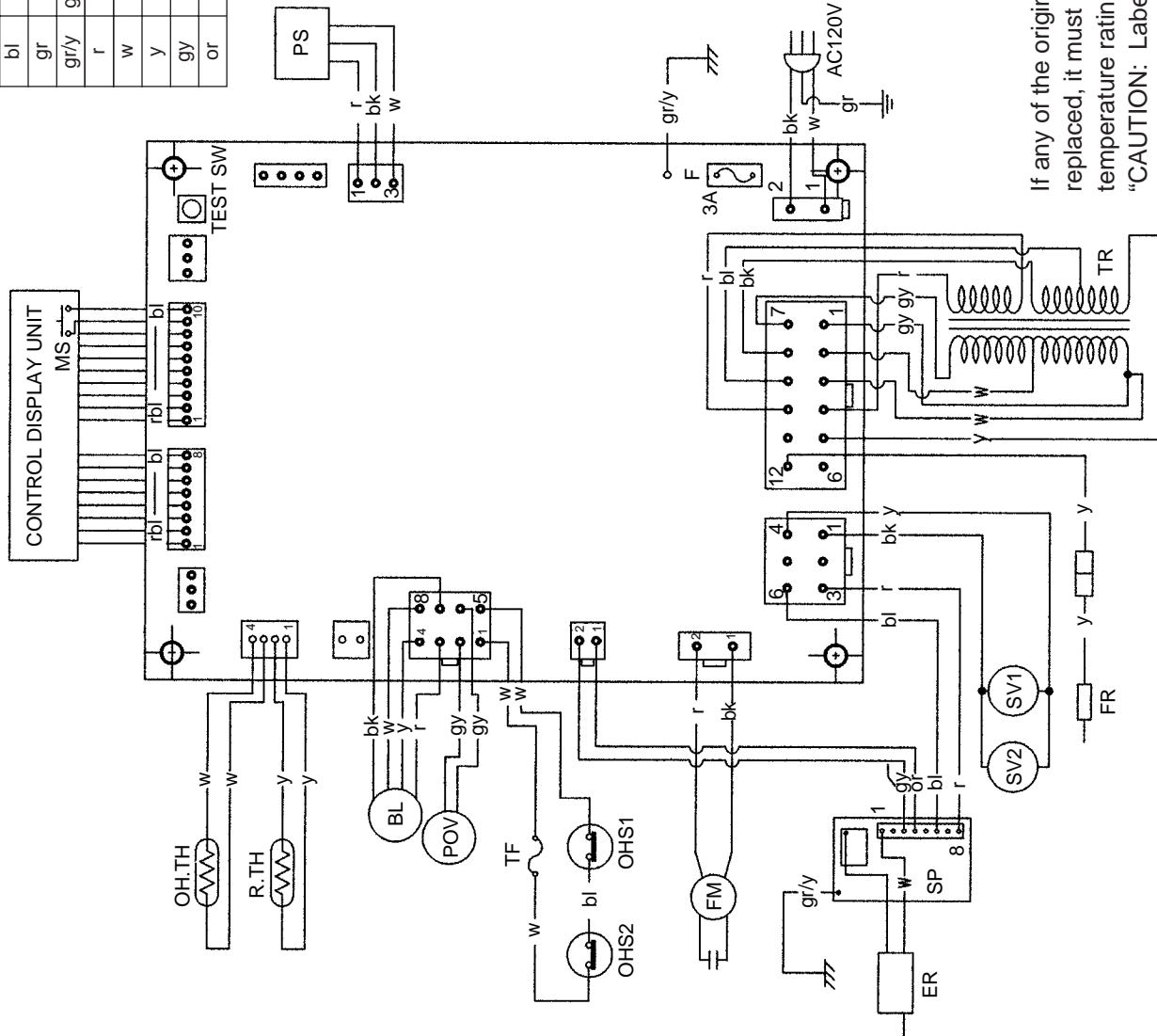

If any of the original wires as supplied with the appliance must be replaced, it must be replaced with a wire of a least a 194°F temperature rating and number 18AWG or its equivalent.

“CAUTION: Label all wires prior to disconnection when servicing controls. Wiring errors can cause improper and dangerous operation.”
Verify operation after servicing

WARRANTY INFORMATION

Please record below:

Purchased from:

Address:

Phone:

Date of Purchase:

Model No.:

Serial No.:

Installed by:

Installer's license No.:

Address:

Phone:

Date of installation:

The installer is responsible for your heater's correct installation.
Keep in a safe place for your records.

CONSUMER'S NOTICE:

Consumer Product Safety Commission suggest all heating systems should be checked annually to be certain venting system is free of foreign matter, and that safety and electrical components be checked for safe operation. See maintenance.

LIMITED WARRANTY RINNAI FURNACE

Rinnai America corporation warrants the products described in this warranty, including any parts and components thereof, to be free from any defects in materials and workmanship for the period specified below, subject to the terms specified in this warranty. This warranty gives you specific legal rights, and you may also have other rights which vary from state to state or country. This warranty extends to the original purchaser and applies to products purchased and retained for use within the U.S.A. and Canada. This warranty applies to furnaces manufactured after June 1, 1995.

MODEL	PERIOD OF COVERAGE	TYPE OF FAILURE
RHFE-263FA	10 YEARS LIMITED*	DEFECTIVE
	FROM DATE OF PURCHASE	HEAT EXCHANGER
RHFE-263FA	FIVE YEARS	DEFECTIVE
	FROM DATE OF PURCHASE	MATERIALS
RHFE-263FA	TWO YEARS	REASONABLE
	FROM DATE OF PURCHASE**	LABOR

In the event of a malfunction, operational difficulty or failure of the product, or any parts or components, during the warranty term, resulting from defects in materials of workmanship, Rinnai will remedy the malfunction, operational difficulty, or failure. The remedy will consist of repair or replacement of the product (including payment of reasonable shipping costs), or refund of the purchase price, at the option of Rinnai. You may obtain the benefits of warranty coverage by returning the product to a qualified Rinnai servicing agent for the appropriate repair or replacement. All warranty service and/or replacement of parts must be performed for you by a servicing agent which has been qualified by Rinnai or its authorized distributor. Any such warranty replacement or repair shall be subject to the terms and conditions of this warranty for the remainder of the original period of coverage. In order to obtain the name and location of the qualified Rinnai servicing agent closest to you, please write Rinnai at the address shown on the back side of the warranty card or call Rinnai at 1-800-621-9419 in U.S.A. and Canada.

This warranty does not cover travel time or any failure due to, operational difficulty, or malfunction due to accident, abuse, misuse, misapplication, improper installation or improper maintenance or service, or from any cause other than defects in materials or workmanship.

If any part of your Rinnai EnergySaver fails because of a manufacturing defect in material or workmanship within two years from the date of original purchase, Rinnai will furnish without charge the required replacement part, shipping and reasonable labor. In addition for the following three years, Rinnai will furnish without charge, the required replacement parts and shipping costs.

In addition, if the heat exchangers fail because of a manufacturing defect in material or workmanship within the third through the fifth year, from the date of original purchase, Rinnai will furnish without charge replacement heat exchangers, shipping costs included. Related service labor, import duties or custom fees and diagnosis calls are not included.

In addition, if the heat exchangers fail because of a manufacturing defect in material or workmanship within the sixth through tenth year from the date of original purchase, Rinnai will make the following allowances, based on retail cost, toward purchase of replacement heat exchangers. Any local transportation, related service labor, import duties or customs fees and diagnosis calls are not included.

Year of Failure	Allowance
6	\$ 50.00 - U.S.A.
7	\$ 40.00 - U.S.A.
8	\$ 30.00 - U.S.A.
9	\$ 20.00 - U.S.A.
10	\$ 10.00 - U.S.A.

Any implied warranties of merchantability and fitness applicable to the equipment are limited in duration to the period of coverage of this express written warranty. Some states/provinces do not allow limitations on how long an implied warranty lasts, so this limitation may not apply to you. Rinnai is not liable for any special, indirect or consequential damages; some states/provinces do not allow the exclusion or limitation of incidental or consequential damages, so this limitation or exclusion may not apply to you.

Rinnai does not authorize any person or company to assume for it any other obligation or liability in connection with the sale, application, engineering, installation, use, removal, return, or replacement of its products; and no such representations are binding on Rinnai. The Warranty Registration Card provided below should be returned within two weeks of purchase to help Rinnai better serve you. However, the return of the Registration Card is not necessary in order to validate this warranty. Proof of purchase with date and serial number is required.

**The labor warranty may be extended 3 additional years for a total of 5 years full warranty. Mail \$ 25.00 per year to Rinnai with the completed warranty registration card (page53).

**FOR EXTENDED WARRANTY - PLEASE REMIT PAYMENT WITH THE CARD
PLEASE RETURN THE CARD TO RINNAI WITHIN TWO WEEKS OF PURCHASE**

SCHEMATIC DIAGRAM

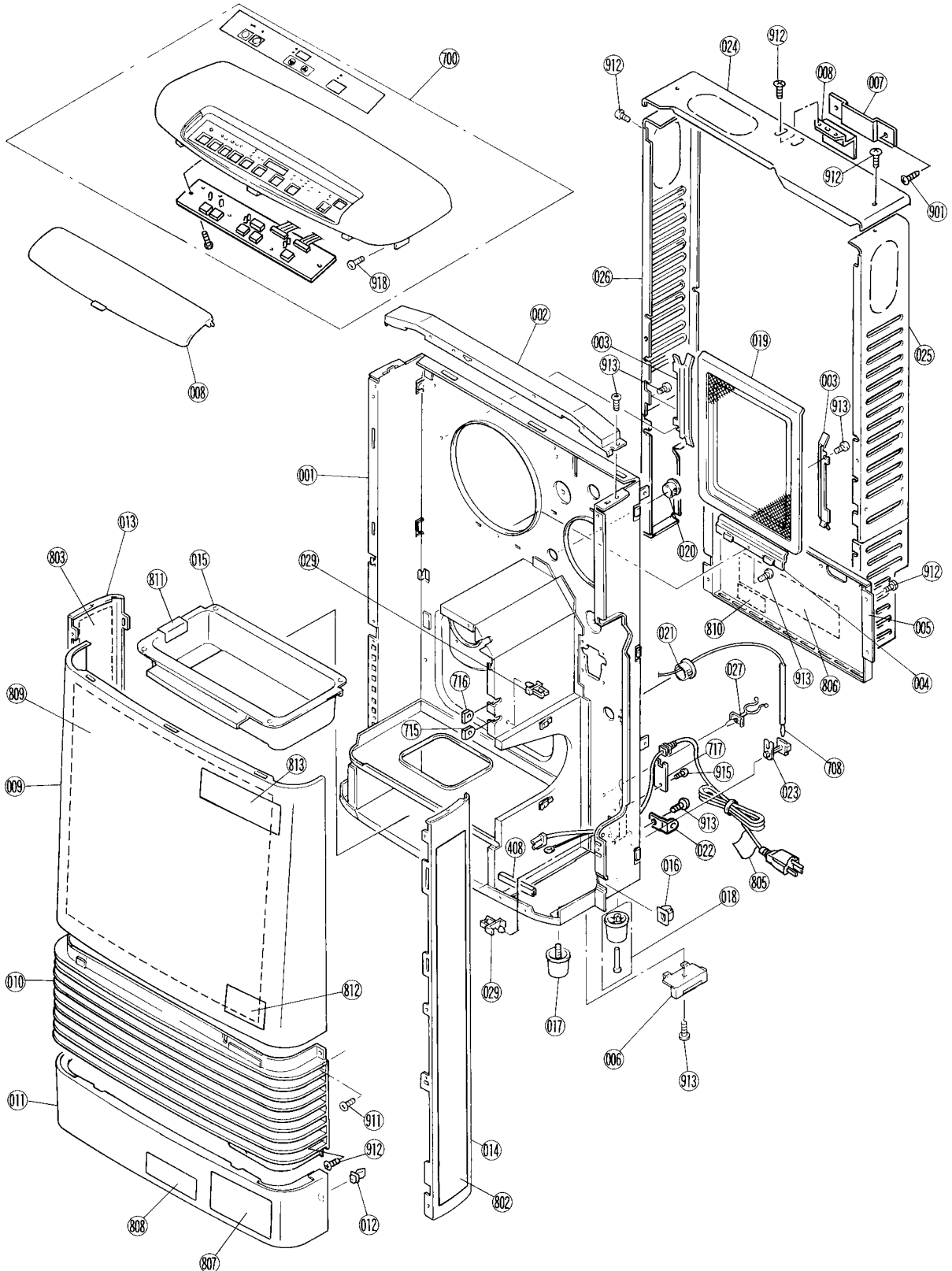

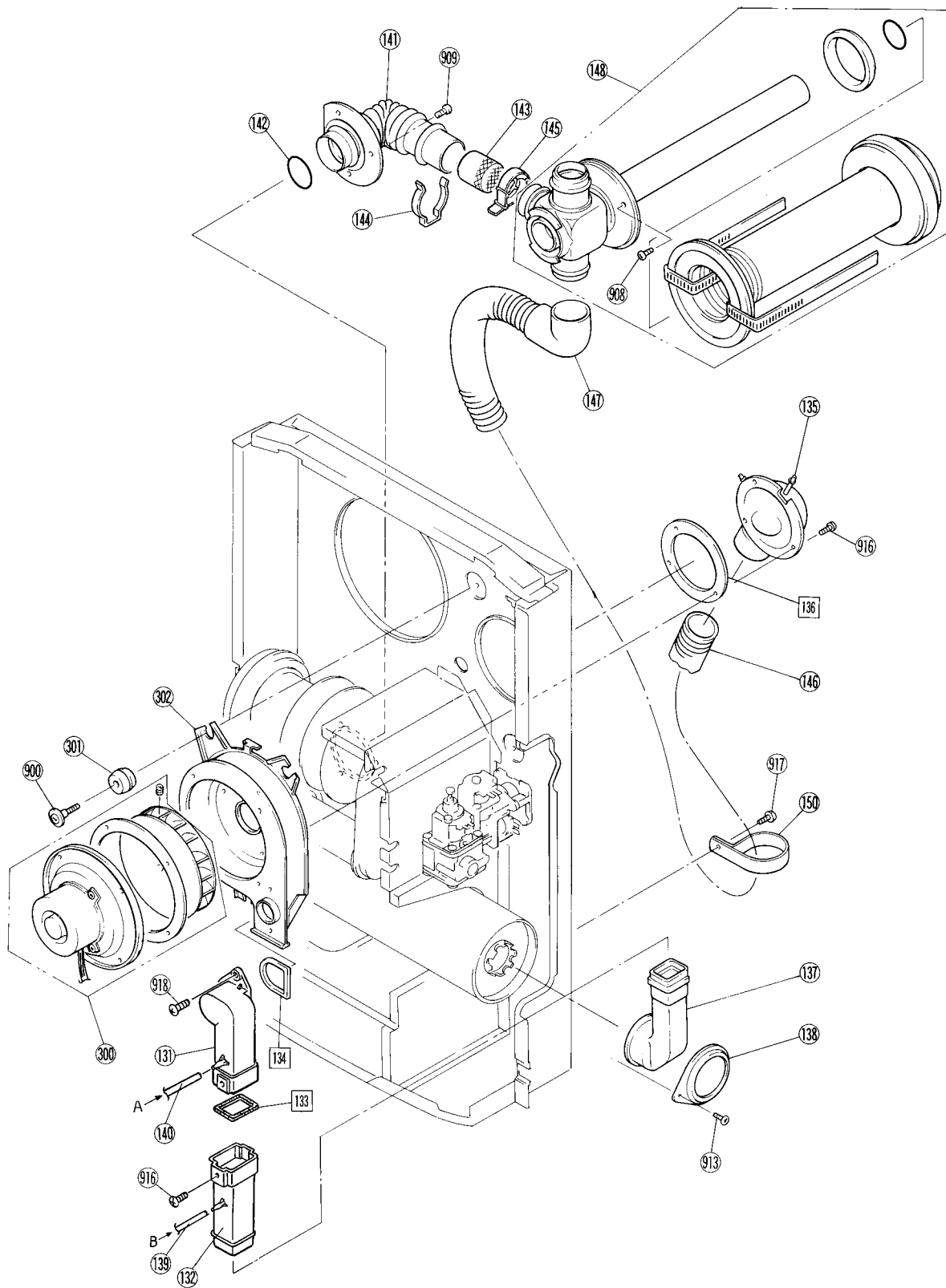

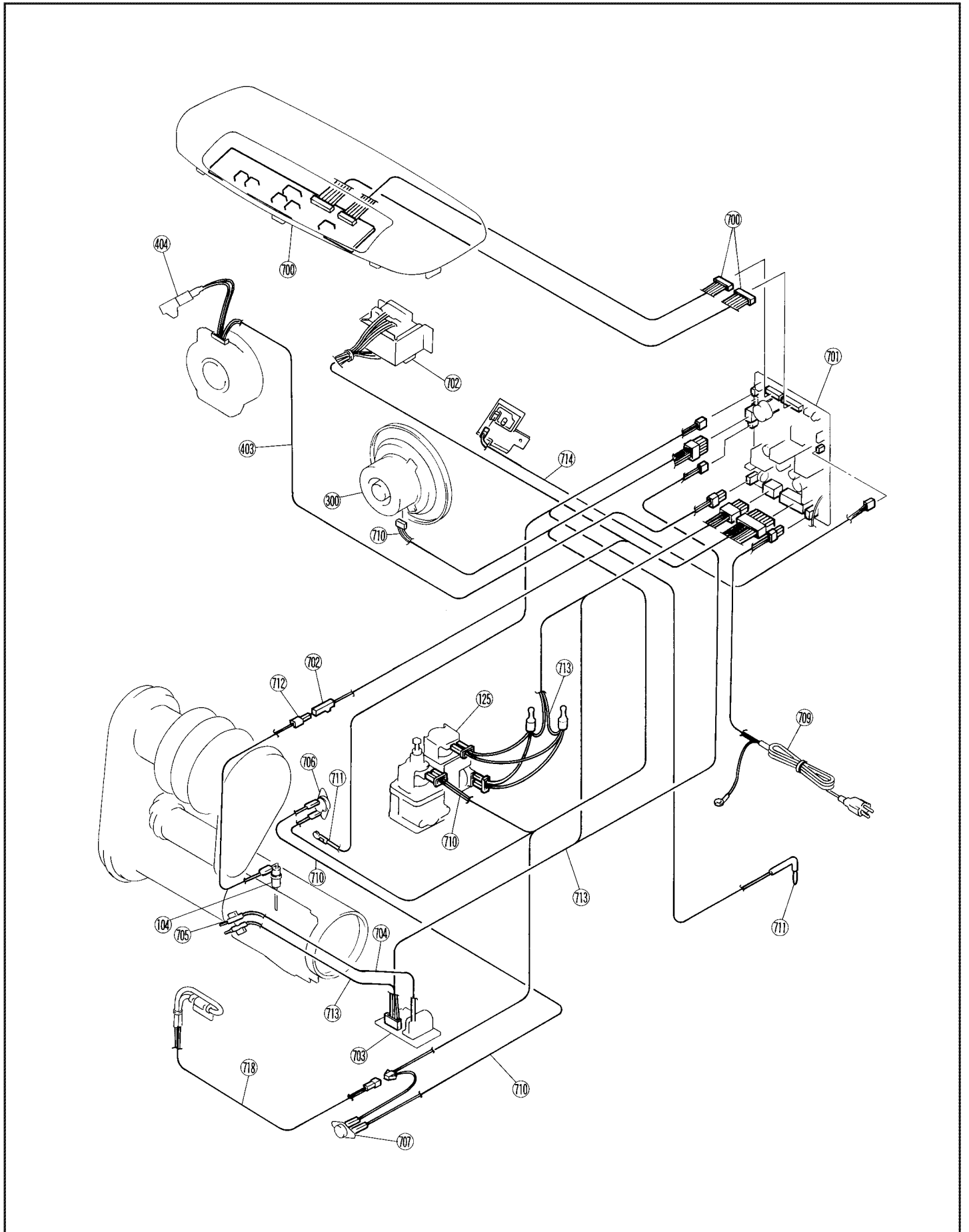

PARTS LIST

No.	PART No.	PART NAME	QTY'	REMARKS
001	308F-301	REAR PANEL ASSY	1	
002	308F-316	TOP PLATE SUPPORTER	1	
003	556F-313	FILTER BRACKET	2	
004	308F-312	FILTER BRACKET	1	
005	308F-324-2	HEAT SHIELD PANEL B	1	
006	308F-454	BRACKET FIXER	2	
007	308F-9077	WALL BRACKET	1	BRACK
008	RHF300-152	SPACER BRACKET	1	
009	308F-401-3	FRONT PANEL	1	RHA WHITE
010	308F-404-3	AIR OUTLET	1	CONSERVATIVE GRAY
011	308F-408-3	UNDER COVER ASSY C	1	RHA WHITE
012	CP-90379	STRIKE	2	
013	308F-402-3	SIDE PANEL LEFT C	1	RHA WHITE
014	308F-403-3	SIDE PANEL RIGHT C	1	RHA WHITE
015	308F-326	HUMIDIFIER TRAY	1	COLOR:BLACK
016	CP-90380	LATCH	2	
017	554F-422	FRONT LEG	2	
018	554F-417	LEG	2	
019	308F-462-3	AIR FILTER ASSY C	1	RHA WHITE
020	CP-90326-2	BUSH	1	
021	CP-90326	BUSH	1	
022	557F-1012	BACK SPACER BRACKET	2	
023	RC-312-628	THERMISTOR HOLDER	1	
024	308F-457-3	BACK SPACER TOP	1	RHA WHITE
025	308F-2050-1	BACK SPACER RIGHT ASSY	1	RHA WHITE
026	308F-2050-2	BACK SPACER LEFT ASSY	1	RHA WHITE
027	CP-90125-2	CABLE CLIP	2	
028	CP-90203-1	CLAMP	2	
029	CP-90107-25	WIRE CLIP	2	
030	CP-90107-4	WIRE CLIP	1	
031	CP-90124-3	CLIP	3	
032	CP-90124-6	CLIP	1	
033	CP-90124-2	CLIP	1	
034	CP-90160-43	CLIP	1	
100	308F-130-2	HEAT EXCHANGER ASSY B	1	
101	308F-216	OHS BRACKET	1	
102	RHF-250-038	ELECTRODE PLATE	1	
103	554F-148	FLAME ROD PACKING	1	
104	1001F-104-3	FLAME ROD	1	
105	556F-215	COMBUSTION CHAMBER FIXER	1	
106	308F-214	HEAT EXCHANGER BRACKET	1	
107	556F-135	SEAL PLATE	2	
108	556F-131	FLANGE	2	
109	308F-201	BURNER BOX ASSY	1	
110	B3A2-4	BURNER ASSY	2	
111	556F-225-2	BURNER SUPPORTER ASSY	1	
112	556F-211	BURNER BOX PACKING	1	
113	308F-209	PRIMARY DAMPER	1	
114	308F-218	SECONDARY AIR DAMPER	1	
115	556F-210	PACKING	1	

No.	PART No.	PART NAME	QTY'	REMARKS
116	554F-114	ELECTRODE MOUNTING PLATE	1	
117	556F-510	ELECTRODE	1	
118	554F-147	ELECTRODE PACKING	1	
119	308F-202-2	MANIFOLD	1	
120	AU129-210	INJECTOR	2	
121	556F-203-2	MANIFOLD PACKING	1	
122	308F-318	WARM AIR SEAL PANEL	1	
123	556F-224	BURNER BOX FITTING PLATE	1	
124	554F-421-2	HEAT EXCHANGER PACKING	1	
125	PC-114-A	GAS CONTROL ASS Y A	1	
126	AU39-965	BLIND SCREW	2	
128	3022-0363	INLET CAP	1	
129	308F-221	CONNECTING TUBE	1	
130	M10B-1-10	O RING	2	
131	308F-2028	AIR INLET UPPER	1	
132	308F-2029	AIR INLET LOWER	1	
133	308F-2027	AIR INLET PACKING	1	
134	308F-612	AIR INLET PACKING	1	
135	553F-340-3	AIR INLET C	1	
136	RHF300F-79	AIR INLET PACKING	1	
137	308F-611	COMBUSTION CHAMBER CONNECTION	1	
138	556F-408	CONNECTION PIPE BRACKET	1	
139	1004F-2052-1	TUBE A	1	CLEAR
140	1004F-2052-3	TUBE C	1	BLACK
141	308F-137	EXHAUST ELBOW ASS Y	1	
142	RHF300-200-e	O RING	1	
143	302F-1103-2	COVER	1	
144	302F-1206	INSULATION CLIP	1	
145	305F-0017	PIPE STOPPER	1	
146	RHF300-51-8	FLEXIBLE HOSE	1	
147	RHF300-52	INLET ELBOW	1	
148	431F-1900	VENT ASS Y	1	
149	308F-2038	SENSOR BRACKET	1	
150	CP-90378	CLAMP	2	
300	308F-430	COMBUSTION FAN MOTOR ASS Y	1	
301	308F-8273	CUSHION RUBBER	7	
302	308F-434	COMBUSTION FAN CASING ASS Y	1	
400	308F-232	CONVECTION FAN CASING	1	
401	308F-231	CONVECTION FAN	1	
402	308F-236	MOTOR BASE	1	
403	308F-2011	CONVECTION MOTOR ASS Y	1	
404	556F-259-2	CAPACITOR	1	
405	308F-313	TF BRACKET	1	
406	308F-325	OHS No.2 BRACKET	1	
407	308F-320	HEAT SHIELD PANEL	1	
408	CP-90157a-75	EDGING	1	
409	308F-2030	P.C.B. TOTAL ASS Y	1	
700	308F-2040	TOP PLATE TOTAL ASS Y	1	
701	ED-263	P.C.B. ASS Y	1	
702	ET-258	TRANSFORMER	1	
703	EI-161	SPARKER	1	
704	308F-2035	HIGH TENSION CORD	1	
705	3022-0344	SLEEVE	1	
706	ES-01171	OVERHEAT SWITCH	1	
707	ES-01170	OVER HEAT SWITCH	1	

No.	PART No.	PART NAME	QTY'	REMARKS
708	1004F-2051	PRESSURE SENSOR	1	
709	CP-90466-3	POWER SUPPLY CORD	1	
710	308F-2045	MOTOR LEAD ASS Y	1	
711	308F-2046	THERMISTOR ASS Y	1	
712	431F-1430	FR LEAD ASS Y	1	
713	308F-2047	SV.IG LEAD ASS Y	1	
714	1004F-2053	SENSOR LEAD ASS Y	1	
715	AU131-236-b	CORD PACKING B	1	
716	AU131-236-a	CORD PACKING A	1	
717	RC-329-1033	POWER SUPPLY CORD BRACKET	1	
718	308F-534	TF LEAD ASS Y	1	
800	308F-2060	OWNER S MANUAL	1	
801	308F-2061	CONVERSION MANUAL	1	
802	CP-72353-1	RATING PLATE	1	
802	CP-72353-2	RATING PLATE	1	
803	CP-72354-1	RATING PLATE	1	
803	CP-72354-2	RATING PLATE	1	
804	CP-72062-7	SPECIFICATION MARK	1	
805	431F-1860	POWER SUPPLY CORD LABEL	1	
806	431F-1840	PROPANE STICKER	1	
806	431F-1841	NG STICKER	1	
807	556F-2065	CAUTION LABEL	1	
808	1001F-1656	CAUTION MARK	1	
809	308F-2063	OPERATION LABEL	1	
810	1001F-1654	EXHAUST CAUTION LABEL B	1	
811	550F-1418	WATER LINE LABEL	1	
812	431F-1830	EXHAUST CAUTION LABEL	1	
813	431F-1862	GAS CHECK LABEL	1	
813	431F-1863	GAS CHECK LABEL	1	
814	BRR37-244	ON-OFF VALVE ASS Y	1	
815	308F-2070-1	CONVERSION KIT(FOR NG)	1	
815	308F-2070-2	CONVERSION KIT(FOR LPG)	1	
900	CP-30310	SCREW		
901	CP-30408	SCREW		
902	CP-30421-1	SCREW		
904	ZAA0316SZ	SCREW		
905	ZAA0422SZ	SCREW		
906	ZBA0408SZ	SCREW		
907	ZBA0416SZ	SCREW		
908	ZBBO410SC	SCREW		
909	ZBDO408SZ	SCREW		
910	ZDAA0410SZ	SCREW		
911	ZEAB0406SC	SCREW		
912	ZEAB0408SC	SCREW		
913	ZEAB0408SZ	SCREW		
914	ZEAB0408UK	SCREW		
915	ZEDB0408SB	SCREW		
916	ZEDB0408SZ	SCREW		
917	ZEDB0410SZ	SCREW		
918	ZEDB0412SZ	SCREW		
919	ZHAA0406SZ	SCREW		
920	ZHAA0410SZ	SCREW		
921	CP-90486	SCREW		

Vent sizes:

5 Vent lengths are available. inch (mm)

- S Vent suits walls 3" ~ 4 1/2" (75 ~ 115)
- A Vent suits walls 4 1/2" ~ 9 1/2" (115 ~ 240)
- B Vent suits walls 9 1/2" ~ 15 3/4" (240 ~ 400)
- C Vent suits walls 15 3/4" ~ 23 5/8" (400 ~ 600)
- D Vent suits walls 23 5/8" ~ 31 1/2" (600 ~ 800)

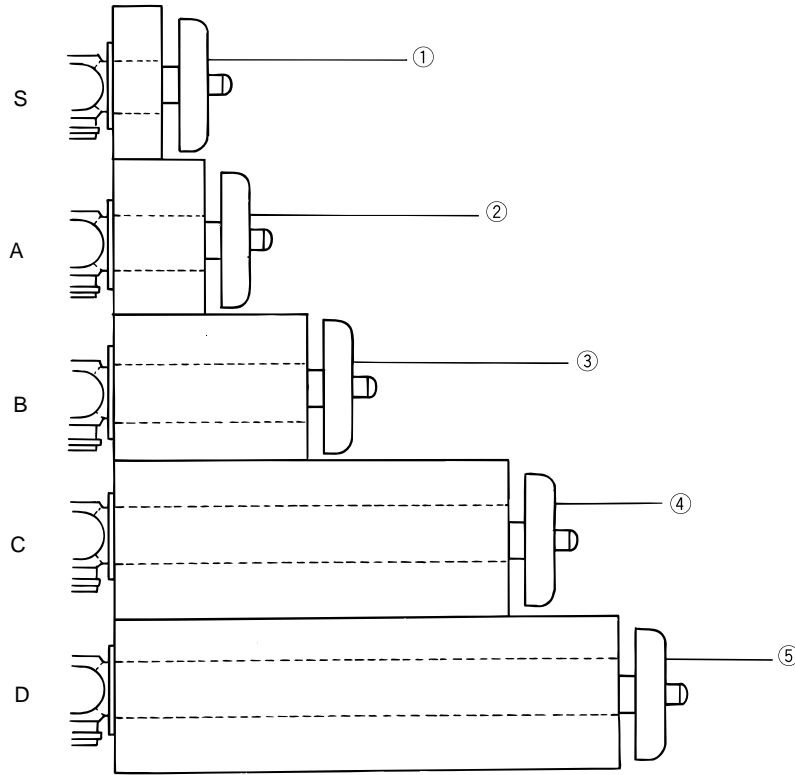

NO.	RANK	PARTS NAME	PARTS NO.	QTY	REMARKS
1	M	VENT KIT - S	FOT-150	1	
2	M	VENT KIT - A	FOT-151	1	
3	M	VENT KIT - B	FOT-152	1	
4	M	VENT KIT - C	FOT-153	1	
5	M	VENT KIT - D	FOT-154	1	
6		RUBBER SEAL		1	SEE PAGE 14.

RHFE-263FA FLOW DIAGRAM

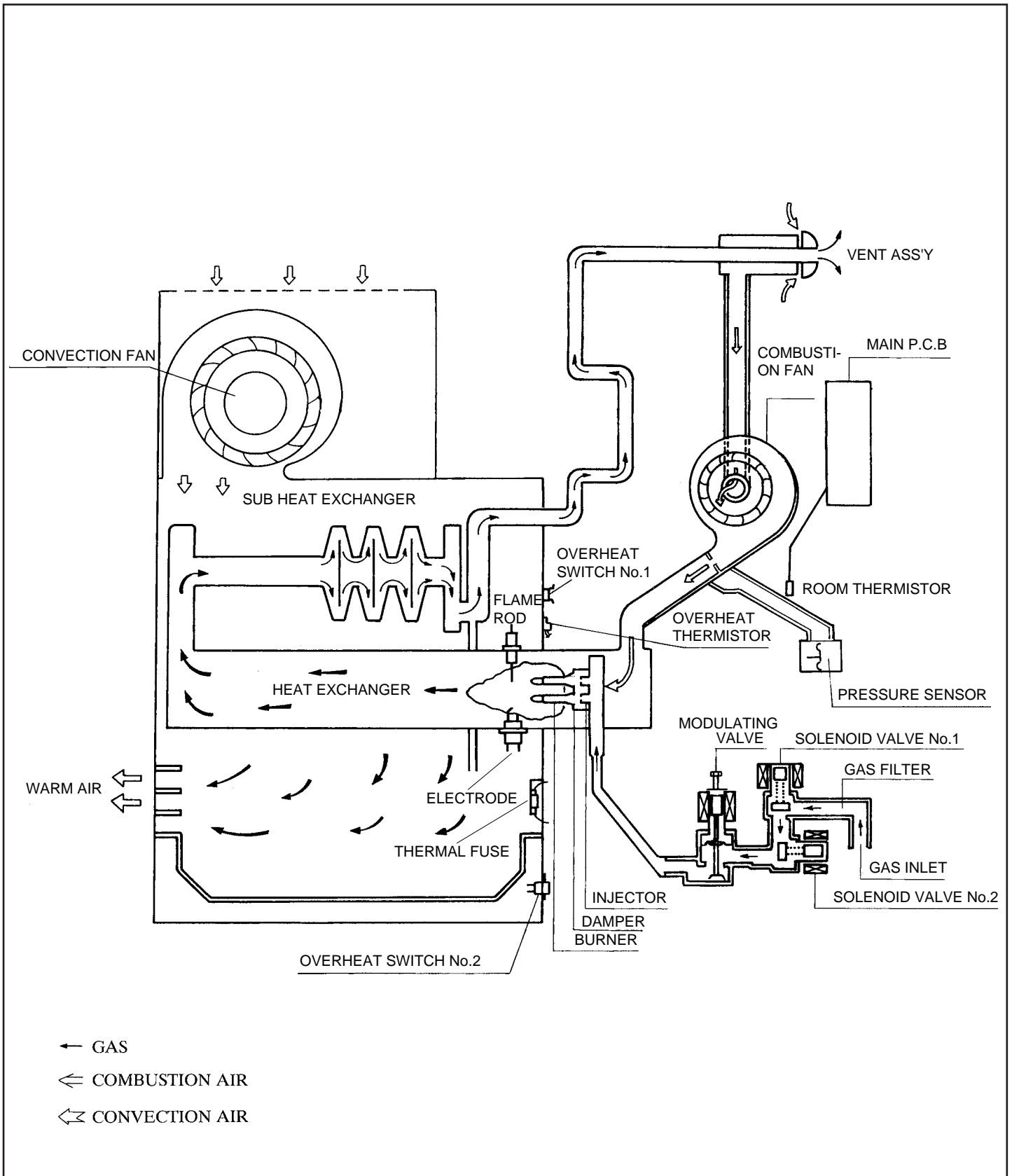

EXTENSION SET PARTS AND INSTALLATION GUIDE

FOT - 155	20"(0.5m)EXTENSION SET
FOT - 156	40"(1m) EXTENSION SET
FOT - 157	80"(2m) EXTENSION SET
FOT - 158	BENT ELBOW SET
FOT - 190	LONG BENT ELBOW SET

Rinnai

- This extension set is to be used for installations requiring extra distance.
MAXIMUM VENT LENGTH 13' WITH 2 ELBOWS

■ NAMES AND NUMBERS OF PARTS

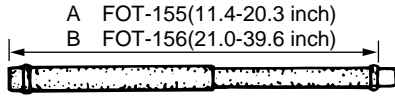

① EXHAUST PIPE



④ BENT ELBOW



PIPE STOPPER B



SCREW A



② EXHAUST PIPE(STRAIGHT) 40 inch

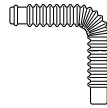

⑤ LONG BENT ELBOW



PIPE CLAMP



SCREW B

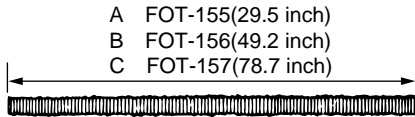

③ AIR INTAKE HOSE



HOSE JOINT



WALL-FIXTURE



PIPE STOPPER A



NUT

		FOT-155	FOT-156	FOT-157	FOT-158	FOT-190
①	A	EXHAUST PIPE	1			
	B	EXHAUST PIPE		1	1	
②		EXHAUST PIPE(STRAIGHT)			1	
③	A	AIR INTAKE HOSE	1			
	B	AIR INTAKE HOSE		1		
	C	AIR INTAKE HOSE			1	
④		BENT ELBOW			1	
⑤		LONG BENT ELBOW				1
		HOSE JOINT	1	1	1	
⑦		PIPE STOPPER A	1	1	2	1
⑧		PIPE STOPPER B	1	1	1	
		PIPE CLAMP	2 SET	3 SET	4 SET	
⑩		WALL FIXTURE	2	3	4	
⑪		NUT	2	3	4	
⑫		SCREW A	2	3	4	
		SCREW B	4	6	8	

■ TYPES COMPATIBLE WITH EXTENSION SET

RHFE-263FA

INSTALLING AN EXTENSION KIT

Installing an extension kit requires construction of an air line and the exhaust line. The air line is connected between the Air Supply Elbow at the rear of the heater and the air inlet port on the Flue pipe.

Similarly, the exhaust line is connected between the joint pipe at the rear of the heater, and the exhaust port on the Flue pipe.

Caution: Check to see there is no debris in pipe or hose.

■ HOW TO INSTALL

MODEL:RHFE-263FA

Example:Extension to left of unit facing front using elbow. (View from rear)

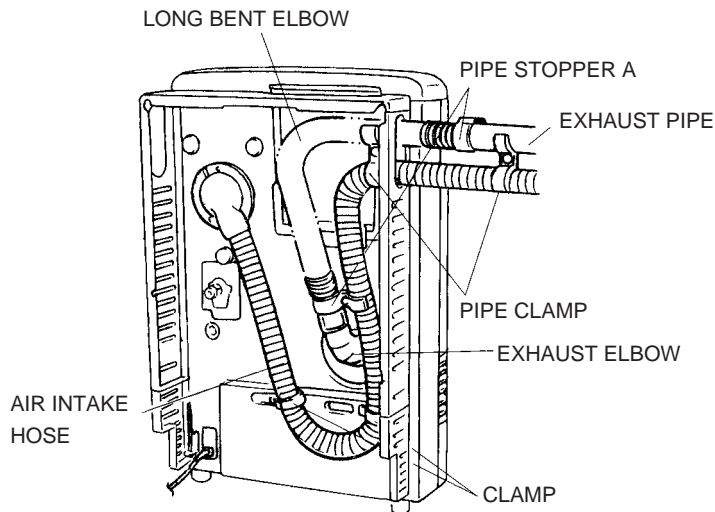

Example:Extension to right of unit facing front using elbow. (View from rear)

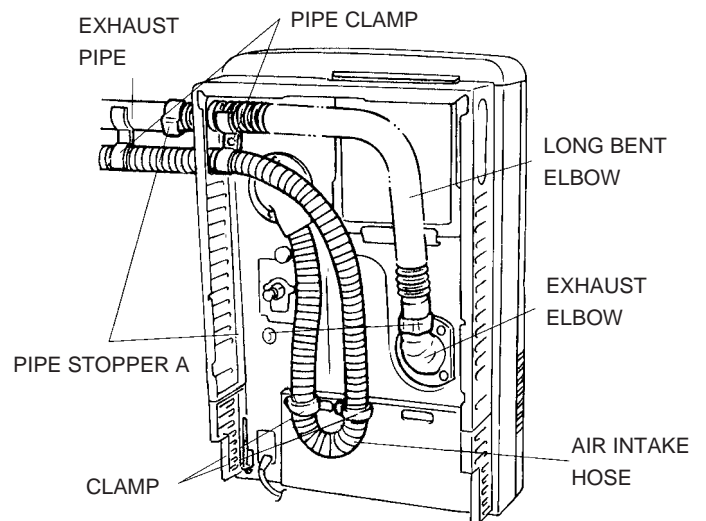

Example:Extension to above of unit (View from rear)

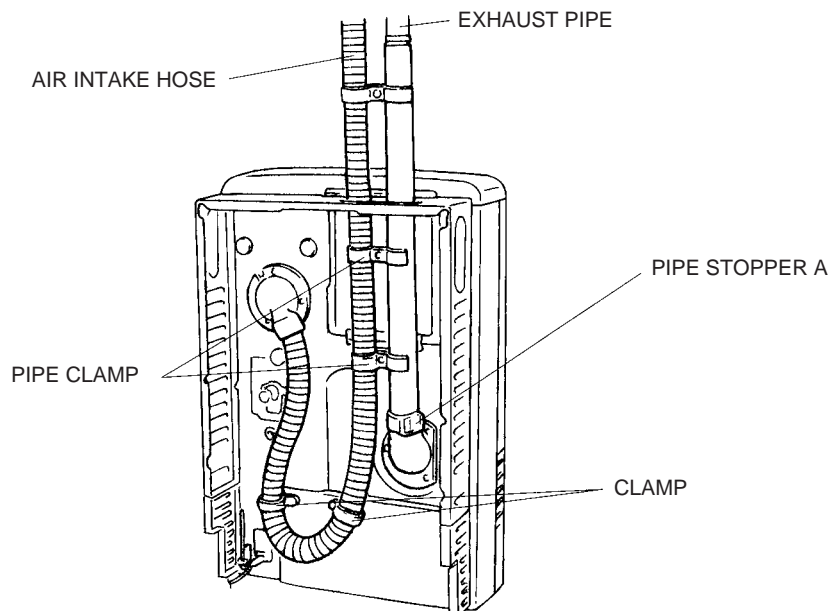

1. How to connect exhaust pipes

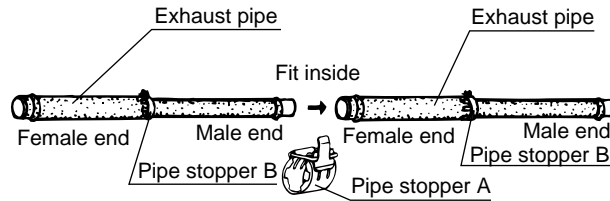

To connect the exhaust pipes, fit the male end into the female end and clamp with pipe stopper A to prevent slipping. The exhaust pipe can be telescoped to the required length; do not cut it.

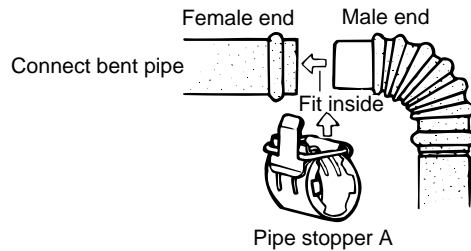

2. How to connect air intake hose

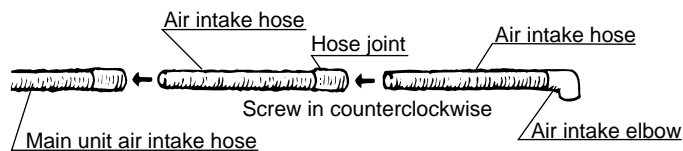

Screw hose joint half of its length onto the air intake hose, then screw another air intake hose into the joint. The hose can be cut to the required length.

IMPORTANT: The PVC air line is longer than the exhaust line and may need to be cut to size. Be sure, however, to thoroughly deburr all rough edges.

3. Affixing the air intake hose and exhaust pipe

NOTE: Maintain 1" clearance between exhaust pipe and combustible materials (0" clearance between exhaust pipe and non-combustible materials).

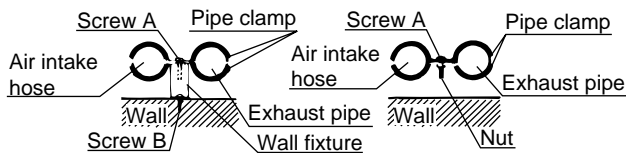

- Set the air intake hose and exhaust pipe into the pipe clamps, screw the clamp onto the wall fixture, and affix to the wall with screw B.
- The air intake hose and exhaust pipe can also be screwed onto the wall using the pipe clamp and the nut.

4. How to use the bent pipe

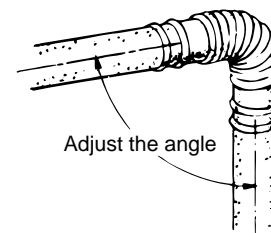

With the exhaust pipes inserted into the ends, bend the bent pipe to the angle required for installation. This part is mainly used for curves and for connection to vent terminal.

■ CAUTIONS

1. Maximum extendable length

FOR BEST ROOM AIR HUMIDITY, KEEP WATER IN THE HUMIDIFIER TRAY.

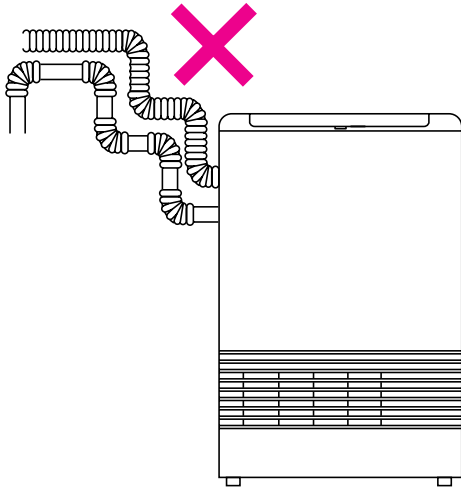

- 13 feet, 2 bends
- The bend where the hose and pipes leave the body is not counted.
- The air intake hose should run along the exhaust pipe.

3. Condensed water formed by combustion, will run back to the unit, and may overflow from the condensation pan if pipes are longer than 8 feet. Therefore, pipes exceeding these lengths should be made to drain to the outside by giving their horizontal portions 3° or more downward and outward slope.

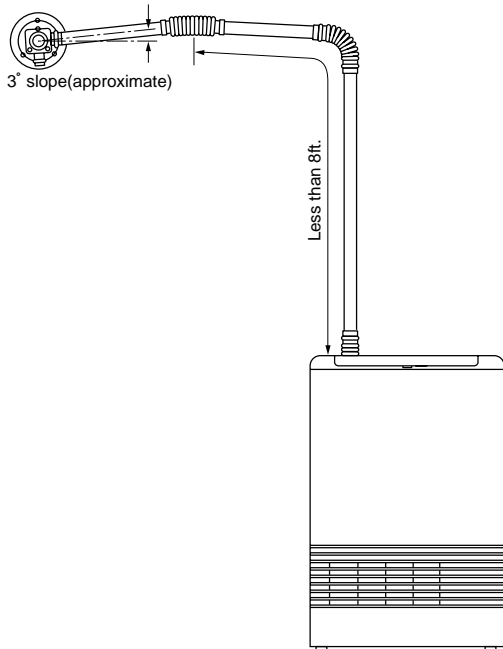

2. To prevent water condensation

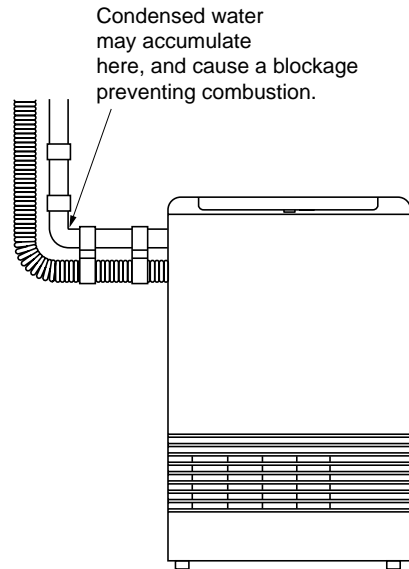

CAUTION

Never allow the exhaust pipe to sag, as condensed water may accumulate and cause incomplete combustion.

4. Wherever the air intake hose and exhaust pipe run sideways, try to have the exhaust pipe on top (to prevent the air intake hose from sagging onto the exhaust pipe).

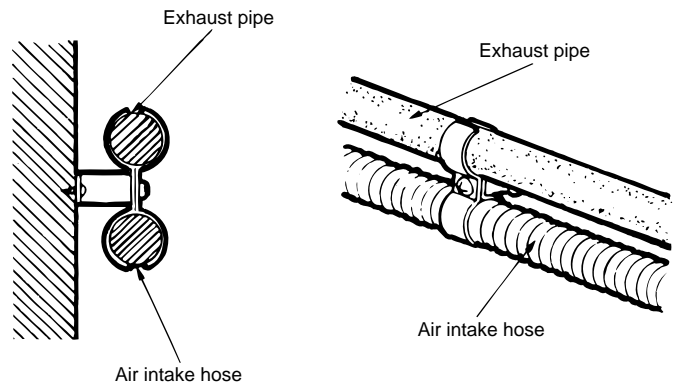

QUALIFIED INSTALLING AGENCY

The installation must conform to local codes, in the absence of local codes, the installation must conform with American National Standard (National Fuel Gas Code) known as NFPA 54 and ANSI Z223.1.1996.

Available from the American National Standards Institute, Inc., 1430 Broadway, New York, N.Y. 10018 or from the National Fire Protection Association, 470 Atlantic Avenue, Boston, Mass. 02210.

TECHNICAL DATA

WEIGHT	DIMENSIONS	GAS RATE (BTU/h)					
		INPUT			OUTPUT		
37.5 Lbs.	Width: 16 3/4" Height: 26 5/8" Depth: 9 13/16"		NG	LP		NG	LP
		LOW	5,500	5,700	LOW	4,450	4,600
		HIGH	11,000	11,000	HIGH	8,800	8,800

Burner Orifices:

RHFE-263FA-P use: Orifice part #AU129-210 x 02-0.90(0.035")

RHFE-263FA-N use: Orifice part #AU129-210 x 02-1.30(0.051")

GAS CONVERSION SPECIFICATIONS

MODEL	GAS TYPE	DIAMETER OF ORIFICE(mm)	PRIMARY DAMPER	SECONDARY DAMPER	MANIFOLD DIFFERENTIAL PRESSURE (W.C.)	
					HI	LO
RHFE-263FA	NG	1.30	308F-209-13	308F-218-1 (3.0 x 10)	2.3"W.C.	0.6"W.C.
RHFE-263FA	LPG	0.90	308F-209-7	308F-218-3 (2.5 x 10)	3.7"W.C.	1.1"W.C.

GAS SUPPLY PRESSURE

	NATURAL	PROPANE
MINIMUM	3.5"W.C.	8.0"W.C.
MAXIMUM	10.5"W.C.	13.0"W.C.

- The minimum inlet gas supply pressures are for the purpose of input adjustment.
- Heaters may be converted from one gas to another using Rinnai conversion kits.

NAME TITLE

COMPANY

ADDRESS

CITY STATE ZIP

PHONE NUMBER



NO POSTAGE
NECESSARY
IF MAILED
IN THE
UNITED STATES



BUSINESS REPLY MAIL
FIRST CLASS NO. 118 PEACHTREE CITY, GA

Rinnai America Corp.
103 International Drive
Peachtree City, Georgia 30269
Attn: Furnace Registrar



EXTENDED WARRANTIES ARE AVAILABLE, CONTACT RINNAI FOR DETAILS.

**Rinnai FURNACE
WARRANTY REGISTRATION CARD**

Owner's Name _____
Installation Address _____
City, State, Zip _____
Dealer's Name _____
Address _____
City, State, Zip _____
Type of Dealer _____
Model _____ Type of Gas _____
Serial No. _____
Date Purchased _____
Comments: _____

PLEASE RETURN THIS CARD TO RINNAI WITHIN TWO WEEKS OF PURCHASE

Rinnai
AMERICA CORPORATION

103 International Drive,
Peachtree City, Georgia 30269
Phone: 1-800-621-9419
Fax: 1-888-474-6624

308F-2060 x 04(00)
Printed in Japan 2003.8