

DISPLAY THIS CARD ON PRINCIPAL FRONTAGE OF WORK



CITY OF PORTLAND BUILDING PERMIT

This is to certify that IRENE STAPLES

Located At 199 ALLEN AVE

Job ID: 2011-11-2590-HVAC

CBL: 343-D-004-001

has permission to Install a Baxi Boiler

provided that the person or persons, firm or corporation accepting this permit shall comply with all of the provisions of the Statutes of Maine and of the Ordinances of the City of Portland regulating the construction, maintenance and use of the buildings and structures, and of the application on file in the department.

Notification of inspection and written permission procured before this building or part thereof is lathed or otherwise closed-in. 48 HOUR NOTICE IS REQUIRED.

A final inspection must be completed by owner before this building or part thereof is occupied. If a certificate of occupancy is required, it must be

11/03/2011

Fire Prevention Officer



Code Enforcement Officer / Plan Reviewer

THIS CARD MUST BE POSTED ON THE STREET SIDE OF THE PROPERTY

PENALTY FOR REMOVING THIS CARD

City of Portland, Maine - Building or Use Permit Application

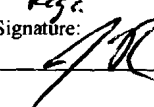
389 Congress Street, 04101 Tel: (207) 874-8703, FAX: (207) 8716

Job No: 2011-11-2590-HVAC	Date Applied: 10/19/2011	CBL: 343- D-004-001	
Location of Construction: 199 ALLEN AVE	Owner Name: ANDY MacMILLAN	Owner Address: 199 ALLEN AVE PORTLAND, ME 04103	Phone:
Business Name:	Contractor Name: Andy MacMillan	Contractor Address: PO Box 626, Rockland, ME 04341	Phone: 207-975-4301
Lessee/Buyer's Name:	Phone:	Permit Type: HVAC - HVAC	Zone: R-5
Past Use: Two family	Proposed Use: Same - Two family - Install Baxi gas boiler in basement	Cost of Work: 6000.00	CEO District:
		Fire Dept: <input type="checkbox"/> Approved <input checked="" type="checkbox"/> Denied <input type="checkbox"/> N/A Signature:	Inspection: Use Group: Type: Main Gas Reg. Signature: 
Proposed Project Description: Install 1 Baxi Direct Vent Boiler		Pedestrian Activities District (P.A.D.)	

Permit Taken By:	Zoning Approval		
1. This permit application does not preclude the Applicant(s) from meeting applicable State and Federal Rules. 2. Building Permits do not include plumbing, septic or electrical work. 3. Building permits are void if work is not started within six (6) months of the date of issuance. False informatin may invalidate a building permit and stop all work.	Special Zone or Reviews <input type="checkbox"/> Shoreland <input type="checkbox"/> Wetlands <input type="checkbox"/> Flood Zone <input type="checkbox"/> Subdivision <input type="checkbox"/> Site Plan <input type="checkbox"/> Maj <input type="checkbox"/> Min <input type="checkbox"/> MM Date: <i>okw/cand/jin</i> <i>11/2/11</i>	Zoning Appeal <input type="checkbox"/> Variance <input type="checkbox"/> Miscellaneous <input type="checkbox"/> Conditional Use <input type="checkbox"/> Interpretation <input type="checkbox"/> Approved <input type="checkbox"/> Denied Date:	Historic Preservation <input checked="" type="checkbox"/> Not in Dist or Landmark <input type="checkbox"/> Does not Require Review <input type="checkbox"/> Requires Review <input type="checkbox"/> Approved <input type="checkbox"/> Approved w/Conditions <input type="checkbox"/> Denied Date: <i>ABM</i>
	CERTIFICATION		

I hereby certify that I am the owner of record of the named property, or that the proposed work is authorized by the owner of record and that I have been authorized by the owner to make this application as his authorized agent and I agree to conform to all applicable laws of this jurisdiction. In addition, if a permit for work described in the application is issued, I certify that the code official's authorized representative shall have the authority to enter all areas covered by such permit at any reasonable hour to enforce the provision of the code(s) applicable to such permit.

SIGNATURE OF APPLICANT	ADDRESS	DATE	PHONE
RESPONSIBLE PERSON IN CHARGE OF WORK, TITLE		DATE	PHONE

BUILDING PERMIT INSPECTION PROCEDURES

Please call 874-8703 or 874-8693 (ONLY)

or email: buildinginspections@portlandmaine.gov

With the issuance of this permit, the owner, builder or their designee is required to provide adequate notice to the city of Portland Inspections Services for the following inspections. Appointments must be requested 48 to 72 hours in advance of the required inspection. The inspection date will need to be confirmed by this office.

- **Please read the conditions of approval that is attached to this permit!! Contact this office if you have any questions.**
 - **Permits expire in 6 months. If the project is not started or ceases for 6 months.**
 - **If the inspection requirements are not followed as stated below additional fees may be incurred due to the issuance of a "Stop Work Order" and subsequent release to continue.**
1. Close-In: (Elec./Fram./Plumbing)
 2. Final Inspection

The project cannot move to the next phase prior to the required inspection and approval to continue, REGARDLESS OF THE NOTICE OF CIRCUMSTANCES.

IF THE PERMIT REQUIRES A CERTIFICATE OF OCCUPANCY, IT MUST BE PAID FOR AND ISSUED TO THE OWNER OR DESIGNEE BEFORE THE SPACE MAY BE OCCUPIED.



PORTLAND MAINE

Strengthening a Remarkable City, Building a Community for Life • www.portlandmaine.gov

Director of Planning and Urban Development
Penny St. Louis

Job ID: 2011-11-2590-HVAC

Located At: 199 ALLEN AVE

CBL: 343- D-004-001

Conditions of Approval:

Zoning

1. This property shall remain a two family dwelling. Any change of use shall require a separate permit application for review and approval.

Building

1. The installation must comply with UL, the Manufacturers' Listing, and State of Maine Gas Regulations.
2. Separate permits are required for any electrical: plumbing, sprinkler, fire alarm, HVAC systems, commercial hood exhaust systems and fuel tanks. Separate plans may need to be submitted for approval as a part of this process.
3. A photoelectric Carbon Monoxide (CO) detector shall be installed in each area within or giving access to bedrooms. That detection must be powered by the electrical service (plug-in or hardwired) in the building and battery.
4. **M1804.2.5 Direct vent terminations.** Vent terminals for direct-vent *appliances* shall be installed in accordance with the manufacturer's installation instructions.
5. **M1804.2.6 Mechanical draft systems.** Mechanical draft systems shall be installed in accordance with their *listing*, the manufacturer's installation instructions and, except for direct vent *appliances*, the following requirements:
 - The vent terminal shall be located not less than 3 feet (914 mm) above a forced air inlet located within 10 feet (3048 mm).
 - The vent terminal shall be located not less than 4 feet (1219 mm) below, 4 feet (1219 mm) horizontally from, or 1 foot (305 mm) above any door, window or gravity air inlet into a *dwelling*.
 - The vent termination point shall not be located closer than 3 feet (914 mm) to an interior corner formed by two walls perpendicular to each other.
 - The bottom of the vent terminal shall be located at least 12 inches (305 mm) above finished ground level.
 - The vent termination shall not be mounted directly above or within 3 feet (914 mm) horizontally of an oil tank vent or gas meter.
 - Power exhauster terminations shall be located not less than 10 feet (3048 mm) from *lot lines* and adjacent buildings.
 - The discharge shall be directed away from the building.

RS

2011-11-0590



FILL IN AND SIGN WITH INK

APPLICATION FOR PERMIT HEATING OR POWER EQUIPMENT

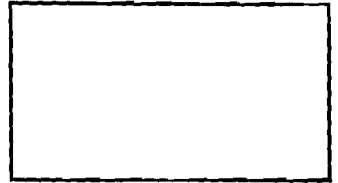

To the INSPECTOR OF BUILDINGS, PORTLAND, ME.

The undersigned hereby applies for a permit to install the following heating, cooking or power equipment in accordance with the Laws of Maine, the Building Code of the City of Portland, and the following specifications:

Location / CBL 199 Allen Ave 3YS D 84 Use of Building 2 unit Date 10-19-11
 Name and address of owner of appliance Andy MacMillan
P.O. Box 626 Rockland, ME 04841
 Installer's name and address same Telephone 207-975-4301

Location of appliance:
 Basement Floor
 Attic Roof

Type of Fuel:
 Gas Oil Solid

Appliance Name: BAXI
 U.L. Approved Yes No

Will appliance be installed in accordance with the manufacture's installation instructions? Yes No

IF NO Explain: _____

The Type of License of Installer:
 Master Plumber # _____
 Solid Fuel # _____
 Oil # _____
 Gas # PNT 57
 Other _____

Type of Chimney:
 Masonry Lined
 Factory built _____
 Metal
 Factory Built U.L. Listing # _____
 Direct Vent
 Type _____ U.L. # _____

Type of Fuel Tank
 Oil
 Gas

Size of Tank _____

Number of Tanks _____

Distance from Tank to Center of Flame _____ feet.

Cost of Work: \$ 5200.00
 Permit Fee: \$ 80

RECEIVED
 OCT 19 2011
 Dept. of Building Inspections
 City of Portland Maine
 10-1-11

Approved

Approved with Conditions

Fire: _____
 Ele.: _____
 Bldg.: _____

See attached letter or requirement

 Inspector's Signature Date Approved

Signature of Installer Andy MacMillan

White - Inspection Yellow - File Pink - Applicant's Gold - Assessor's Copy

BAXI

LUNA 3 COMFORT

EN

High efficiency gas fired wall mounted combination boiler

Installation and servicing instructions

FR

Chaudière murale à gaz à rendement élevé

Notice d'installation et d'entretien



right or left).

2. Measure the distance from the outside wall face to the elbow (Fig. 3). This dimension will be known as 'X'.
3. Taking the, mark dimension 'X' as shown (Fig. 4). Measure the length of waste material, and transfer the dimension to the flue duct (Fig. 4).
4. Remove the waste from both. Ensure that the cut ends are square and free from burrs.
5. Remove the flue elbow from the adaptor.

IMPORTANT: Check all measurements before cutting. Clearance to combustible materials when using concentric system is zero.

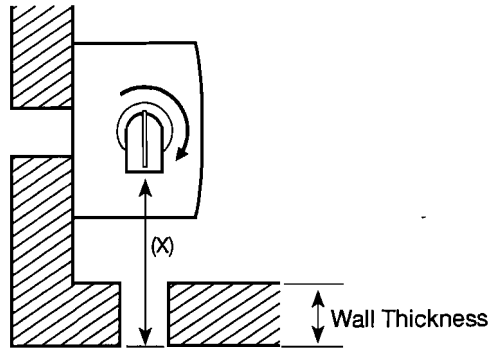
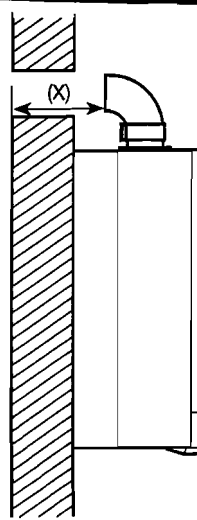

Fig. 3

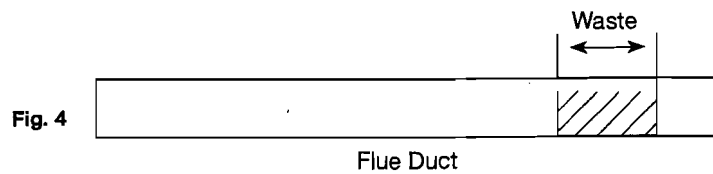
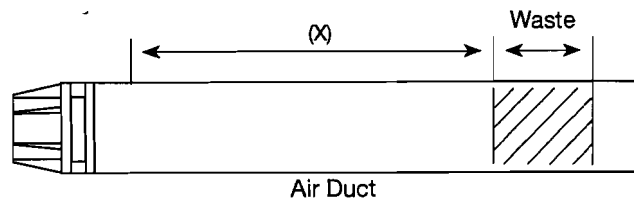

Fig. 4