

**D6** TYPICAL DETAIL AT EXTERIOR PIER  
3/4" = 1'-0"

**D5** SECTION AT EXTERIOR WALL  
3/4" = 1'-0"

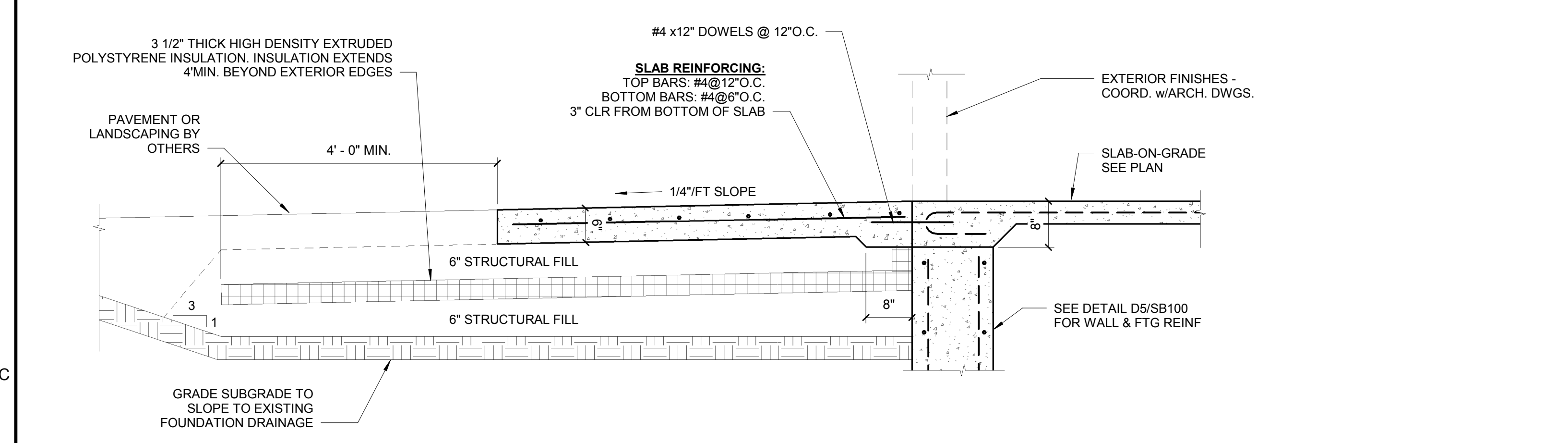

**C6** DETAIL  
3/4" = 1'-0"

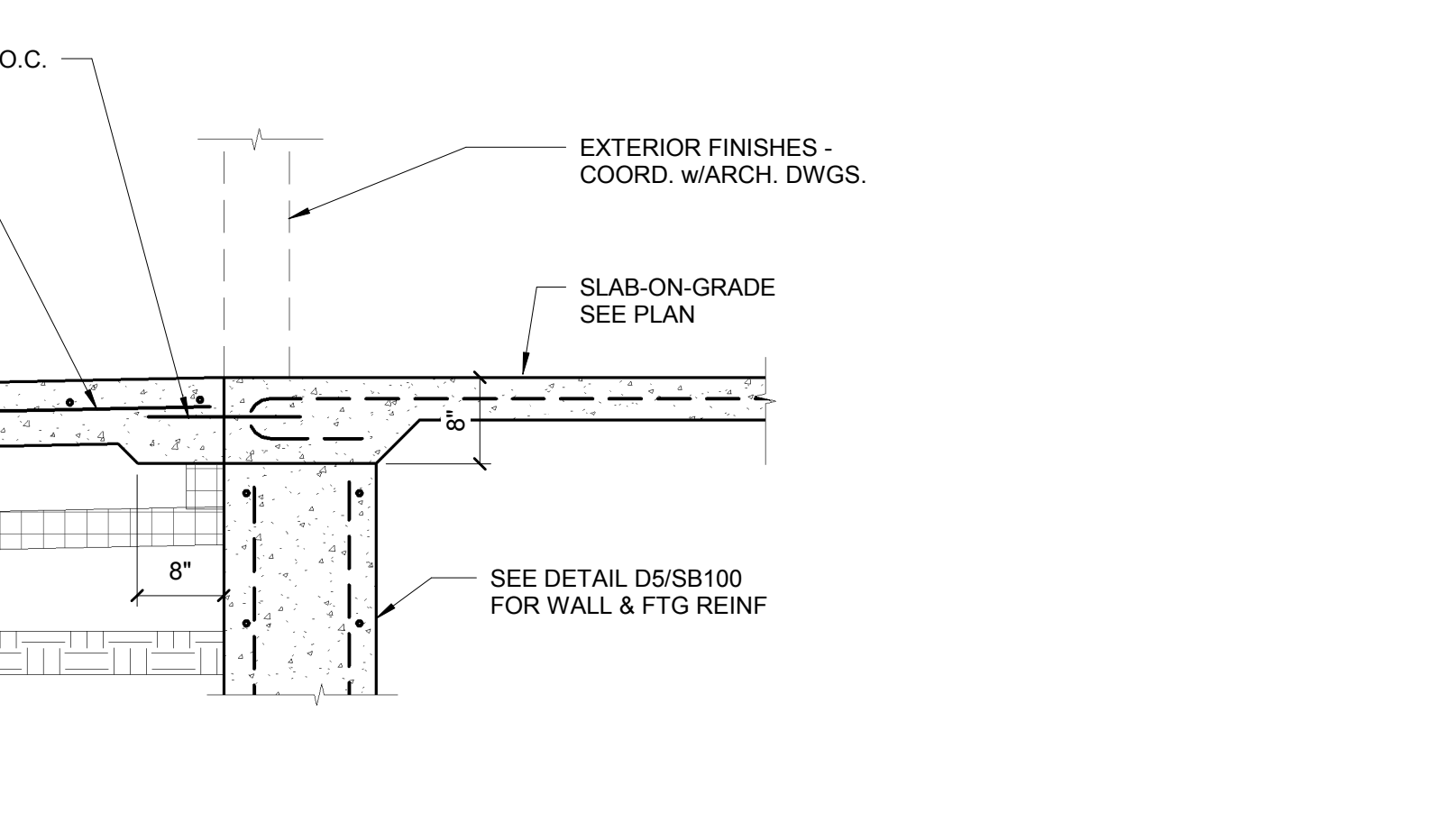

**B5** CMU TO FOOTING DETAIL AT DOORWAY  
3/4" = 1'-0"

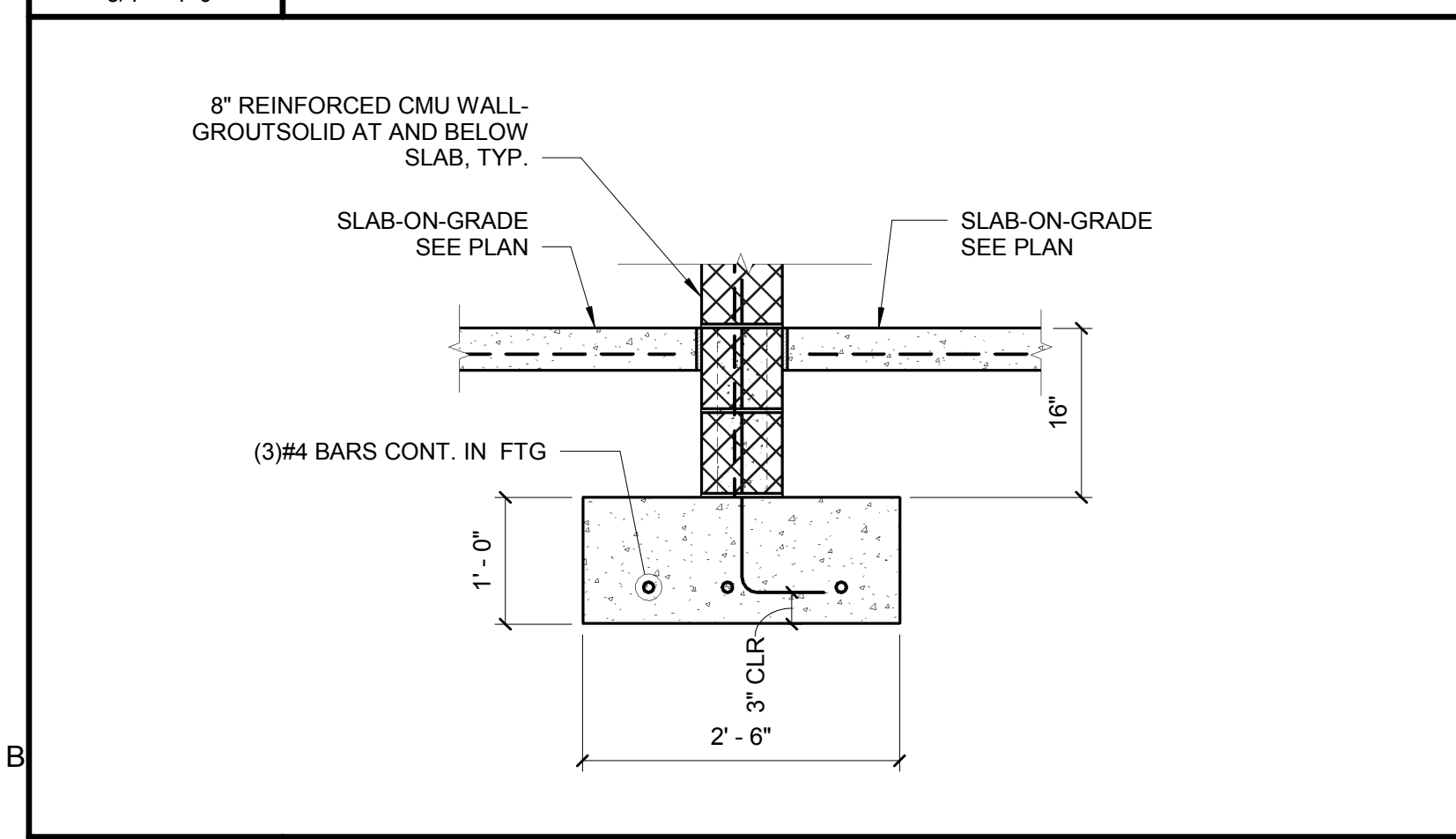

**B6** CMU TO FOOTING DETAIL  
3/4" = 1'-0"

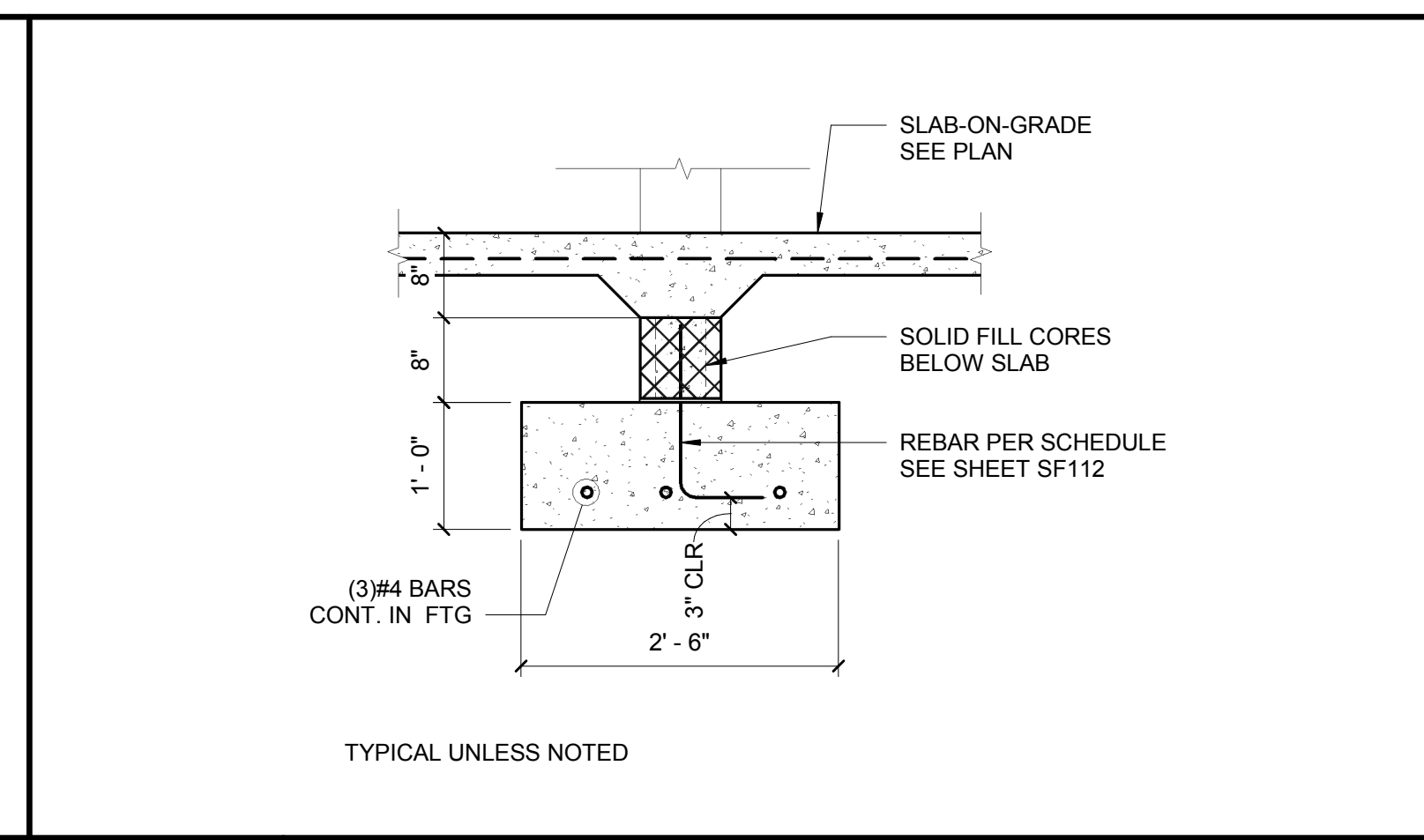

**B5** CMU TO FOOTING DETAIL AT DOORWAY  
3/4" = 1'-0"

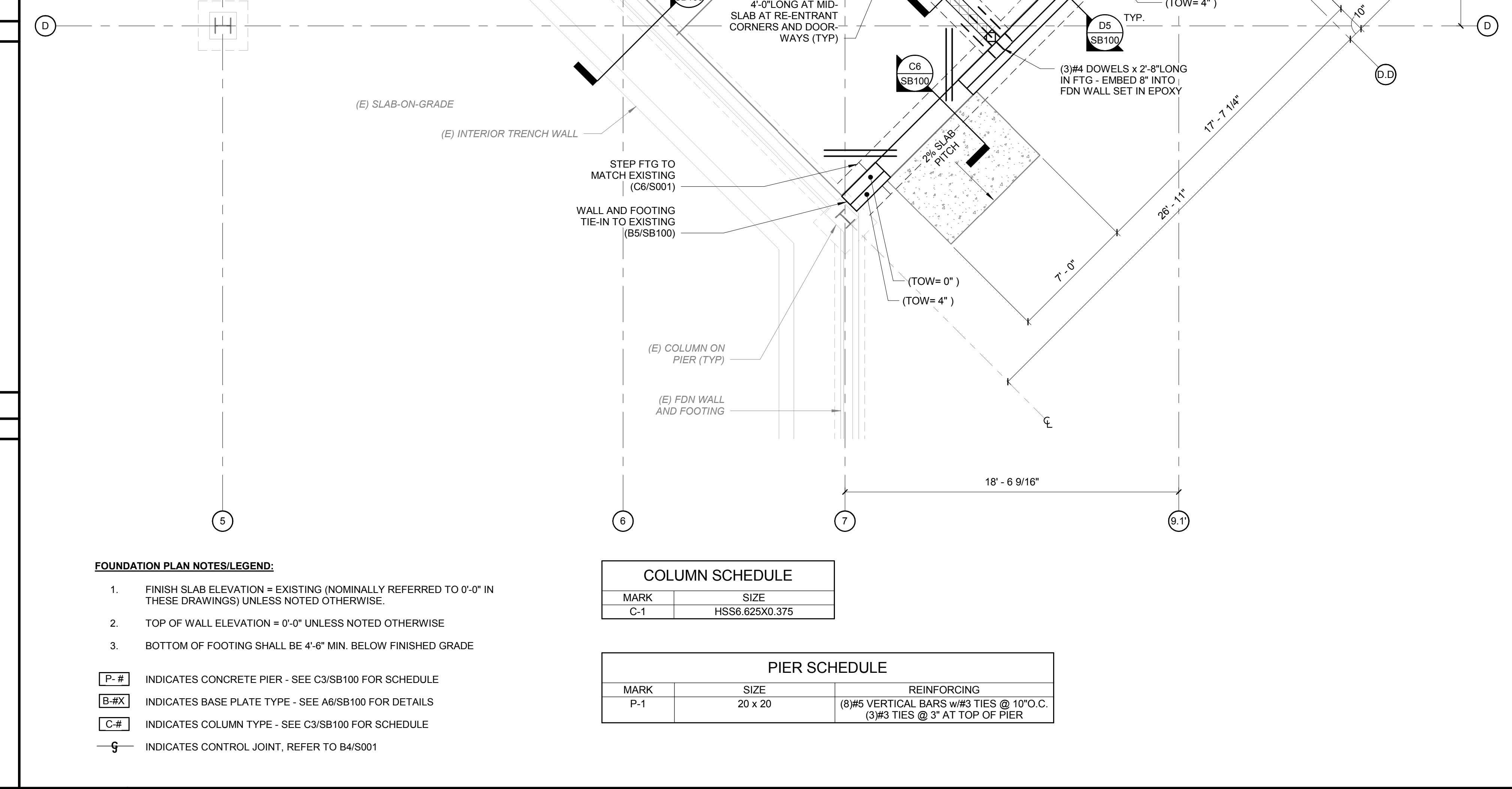

**B3** STRUCTURAL - FOUNDATION PLAN  
1/4" = 1'-0"

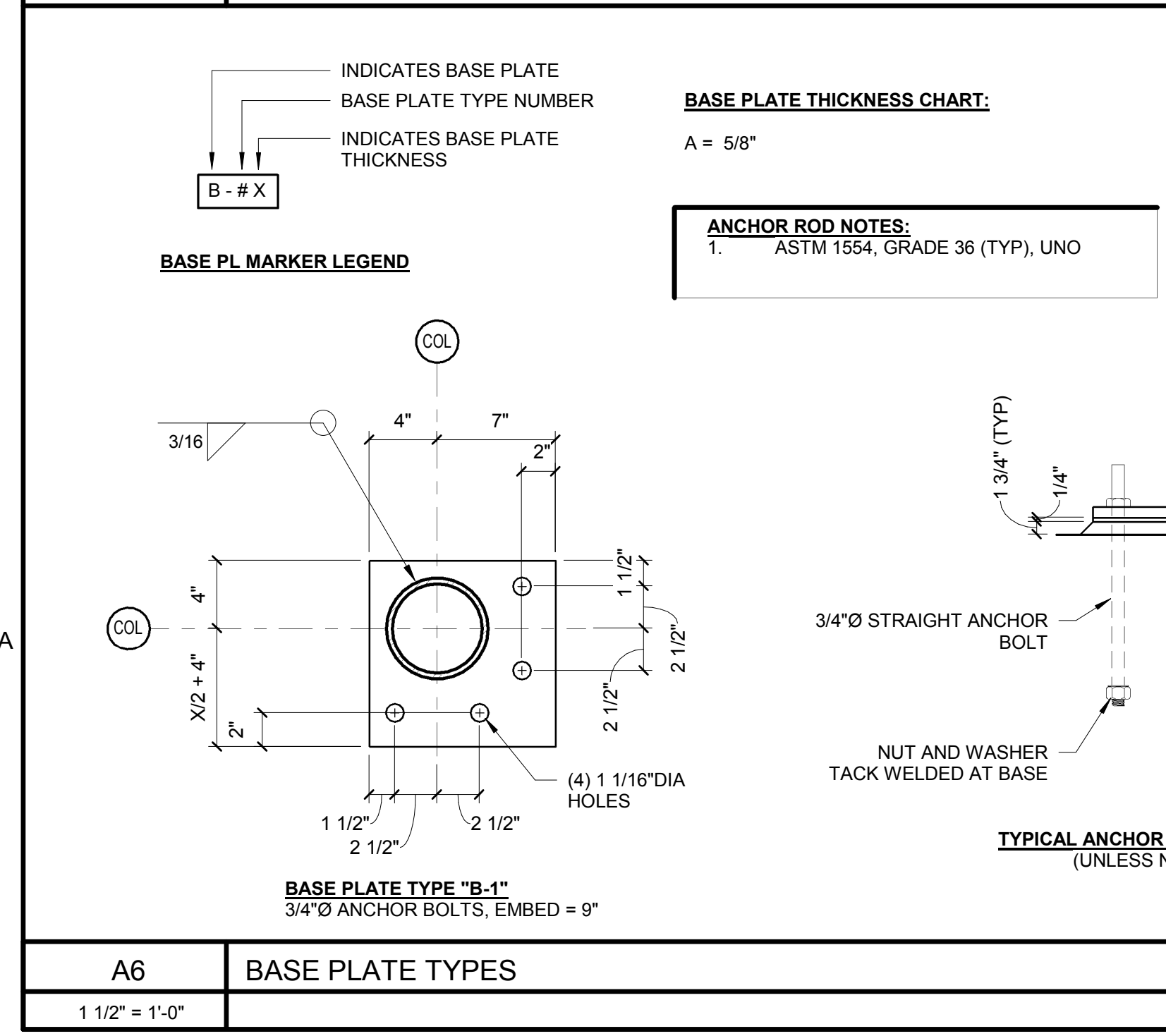

**A6** BASE PLATE TYPES  
1 1/2" = 1'-0"

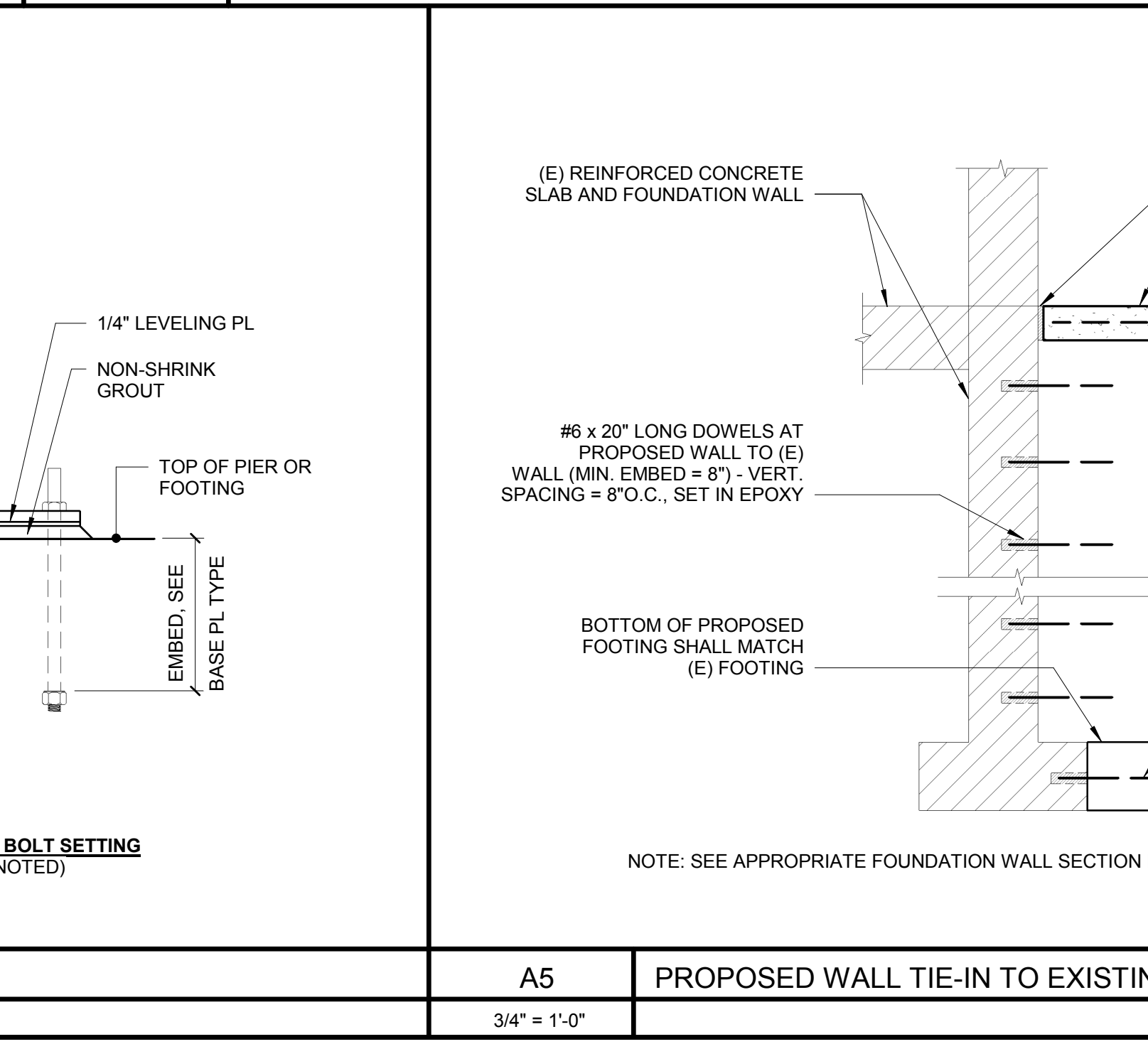

**A5** PROPOSED WALL TIE-IN TO EXISTING  
3/4" = 1'-0"

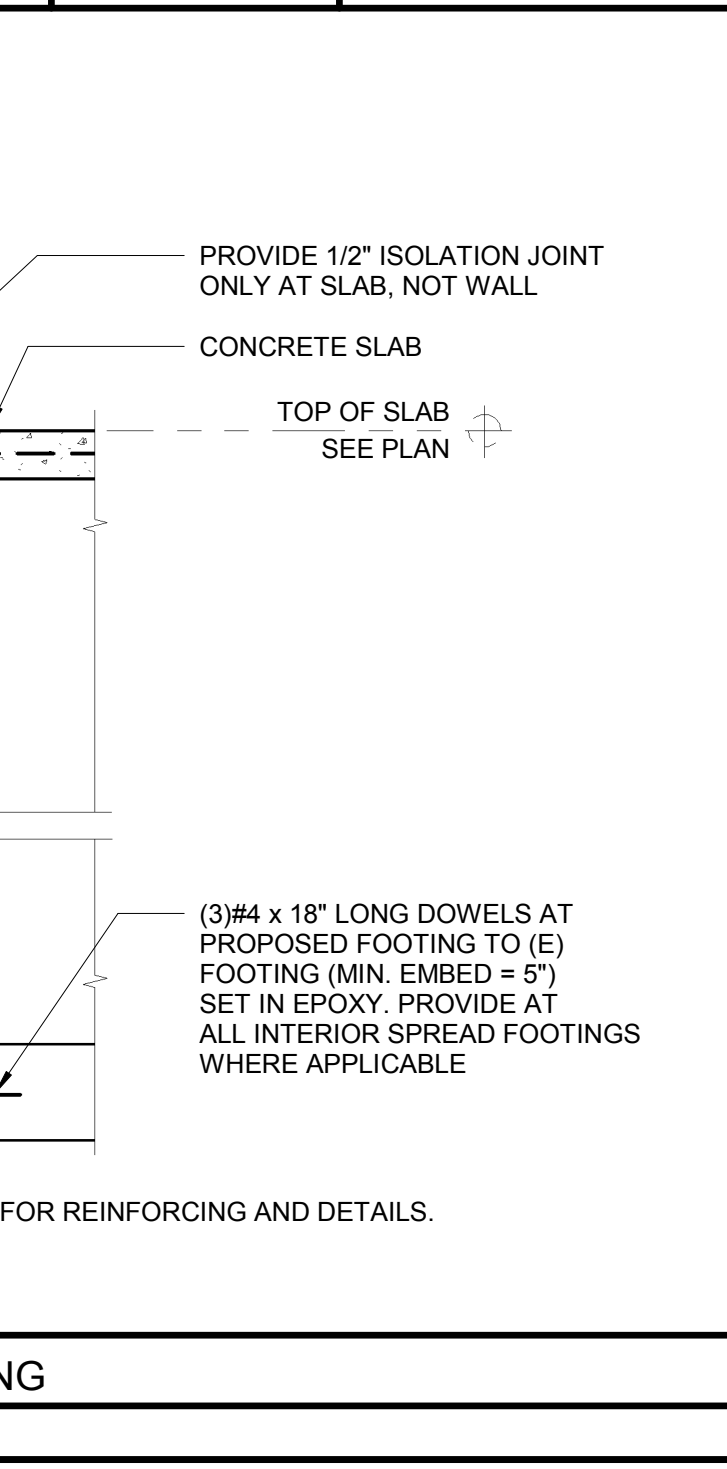

**A3** SECTION AT EXISTING WALL  
3/4" = 1'-0"

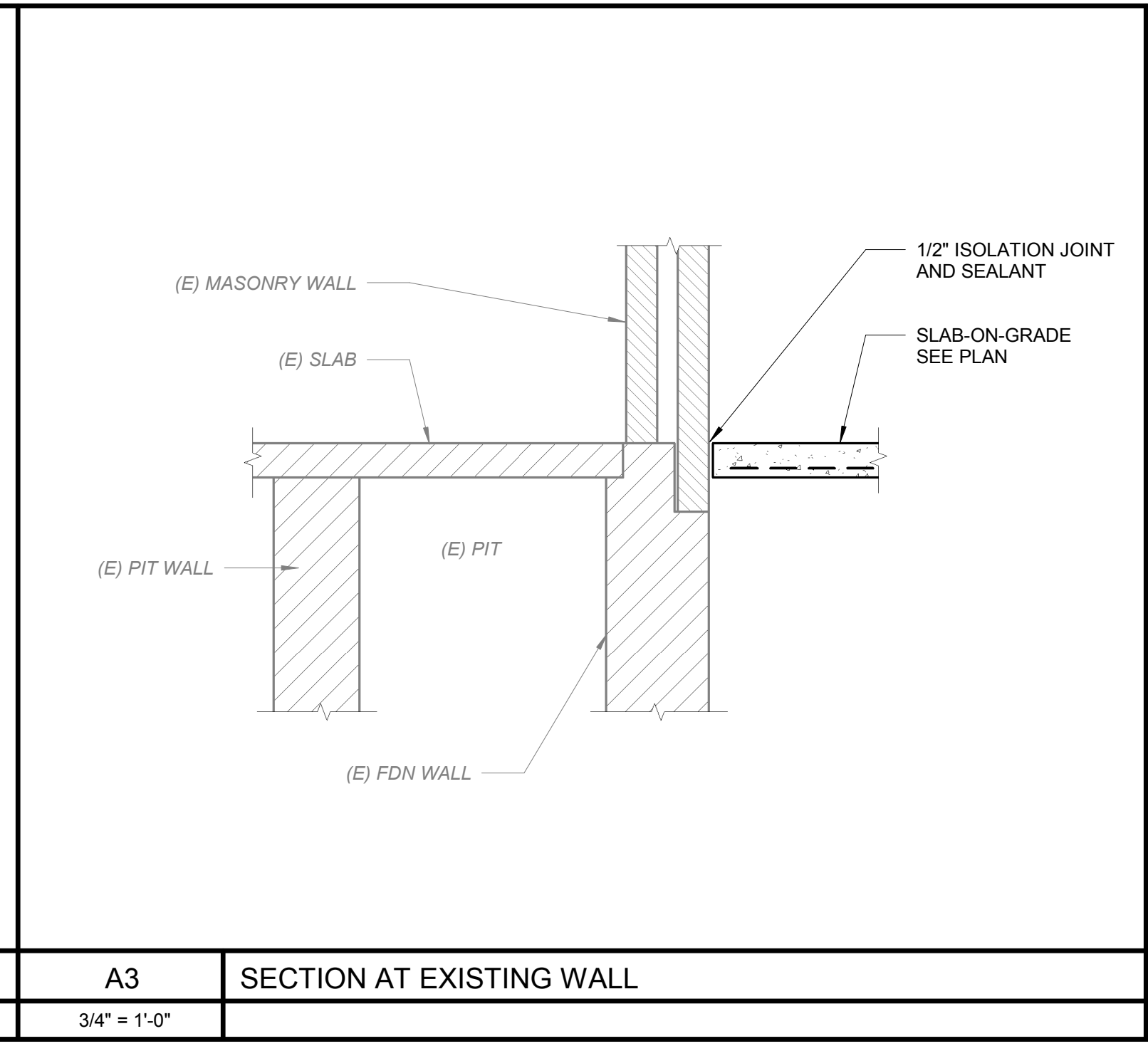

**A3** SECTION AT EXISTING WALL  
3/4" = 1'-0"

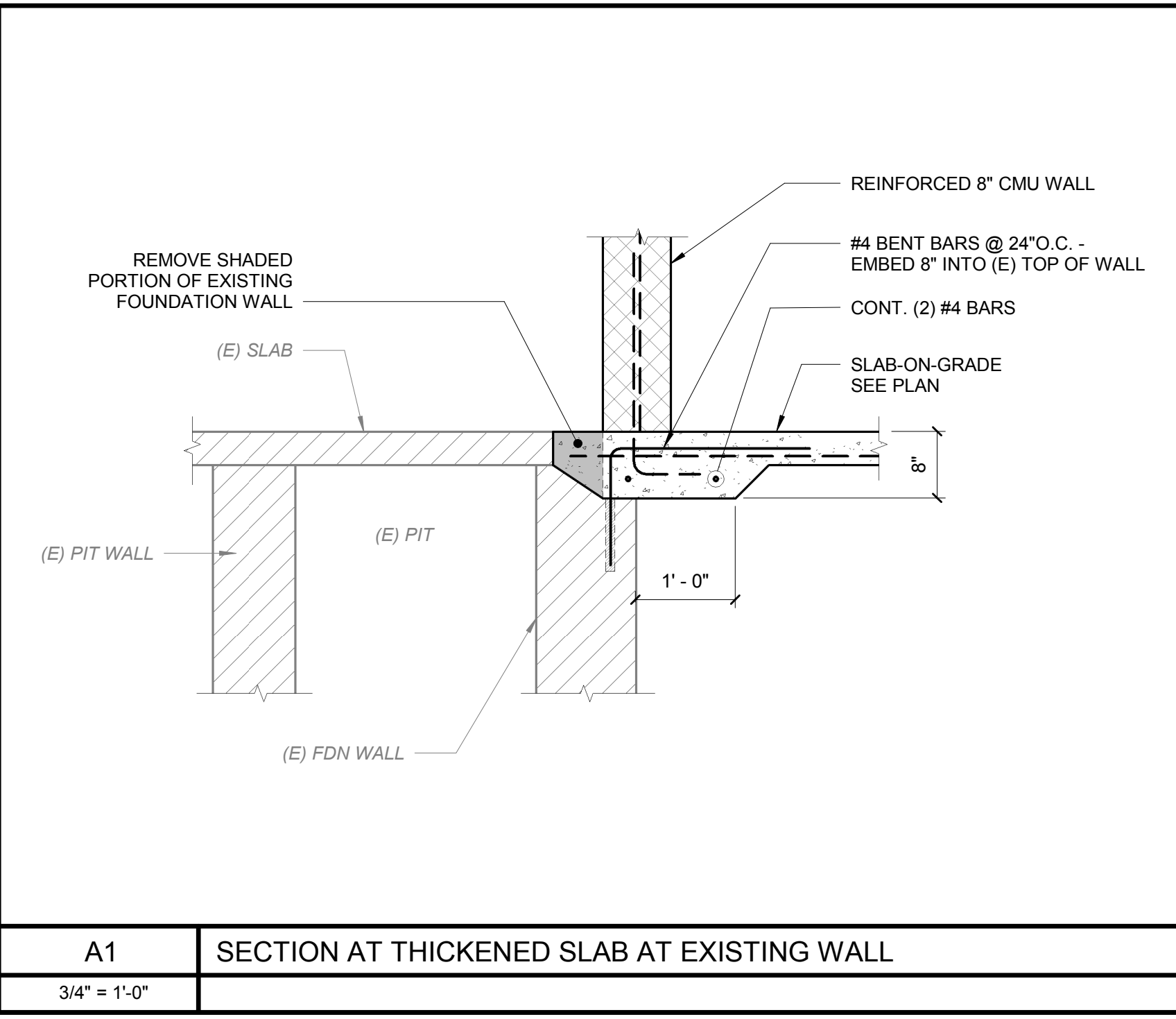

**A1** SECTION AT THICKENED SLAB AT EXISTING WALL  
3/4" = 1'-0"