

102 Allen Ave.

Site/plot plan.

R5 Zone

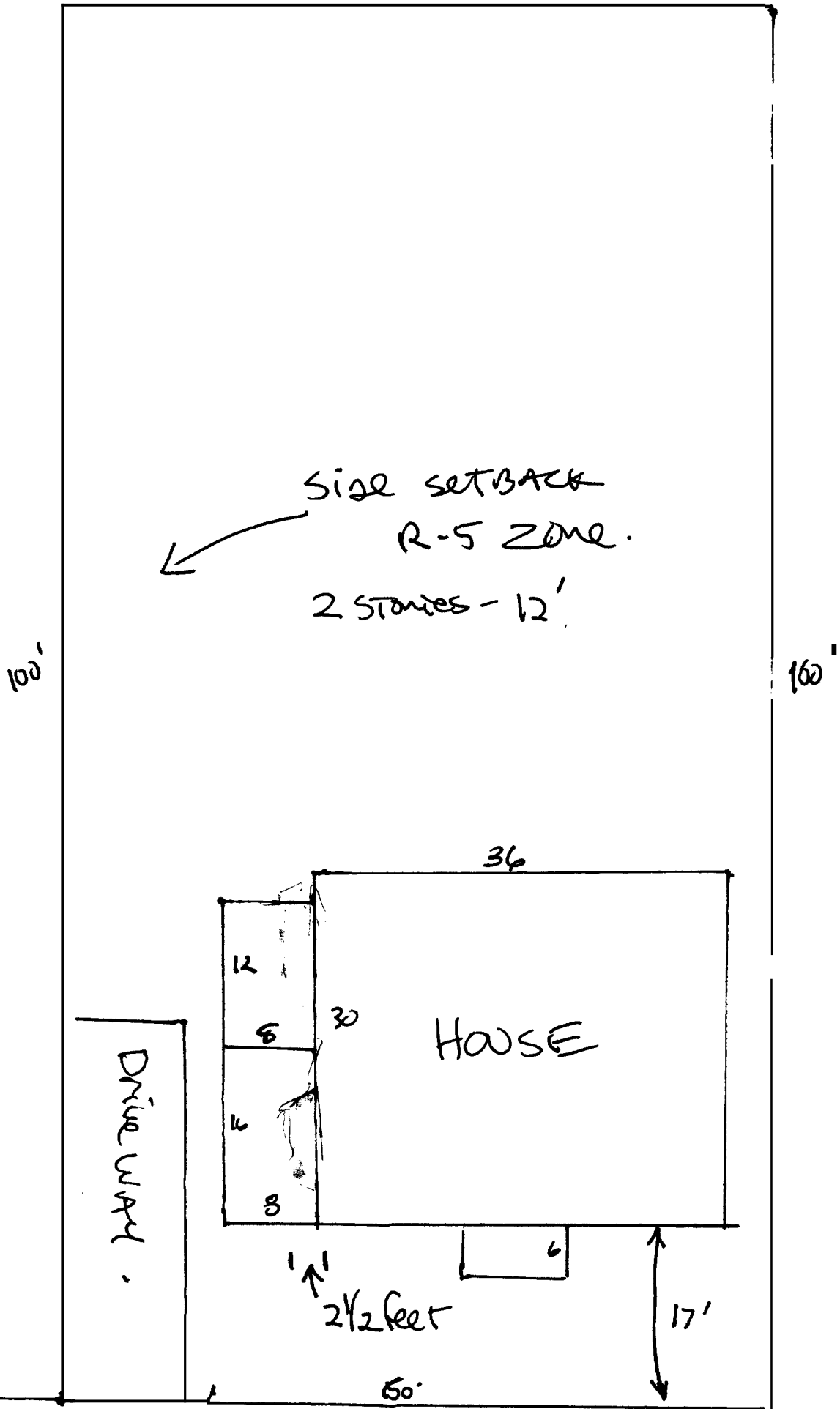

ALLEN AVE.

0/8
Setback

Bay window
& stairs
removed -

- sun porch &
porch
removed

Foundation plan

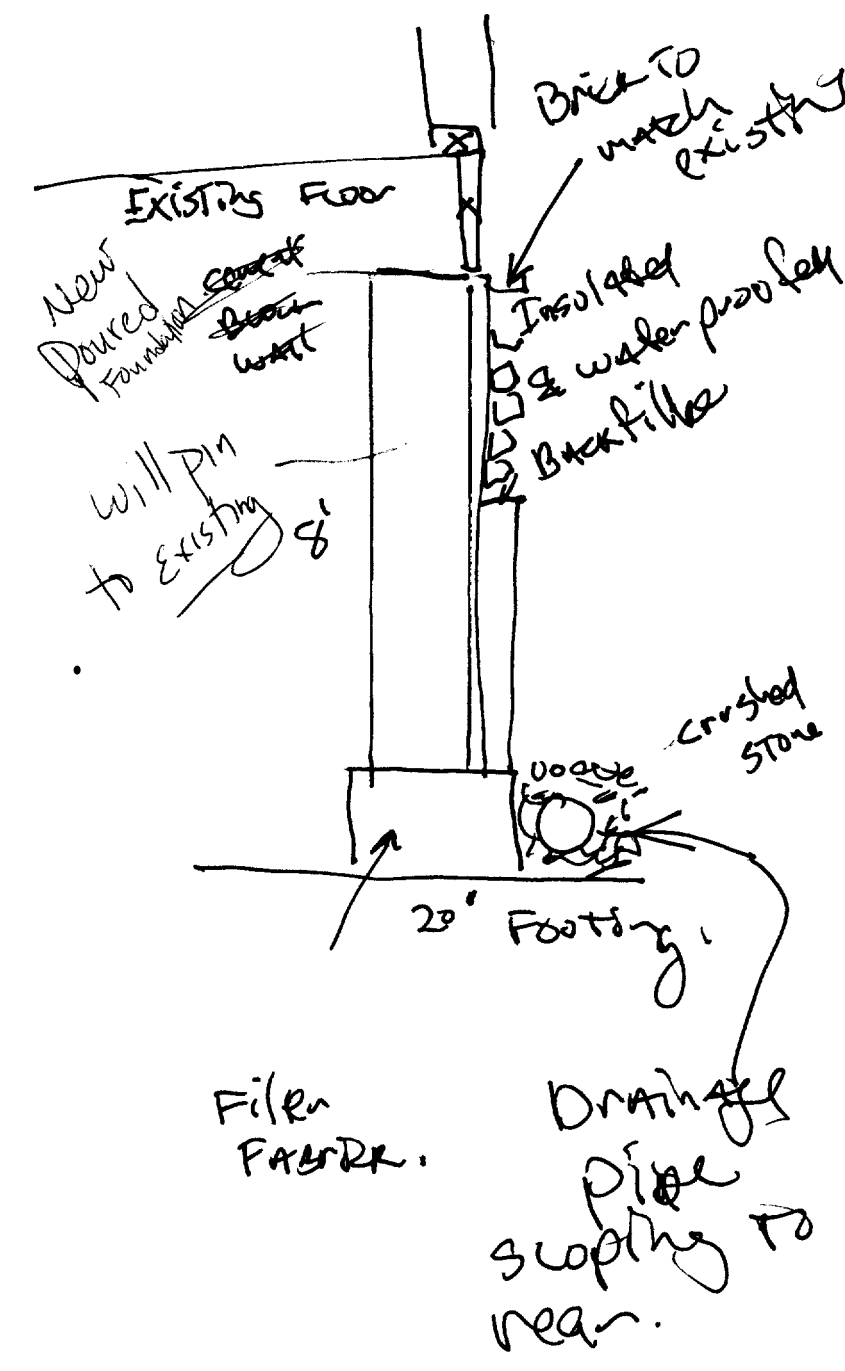
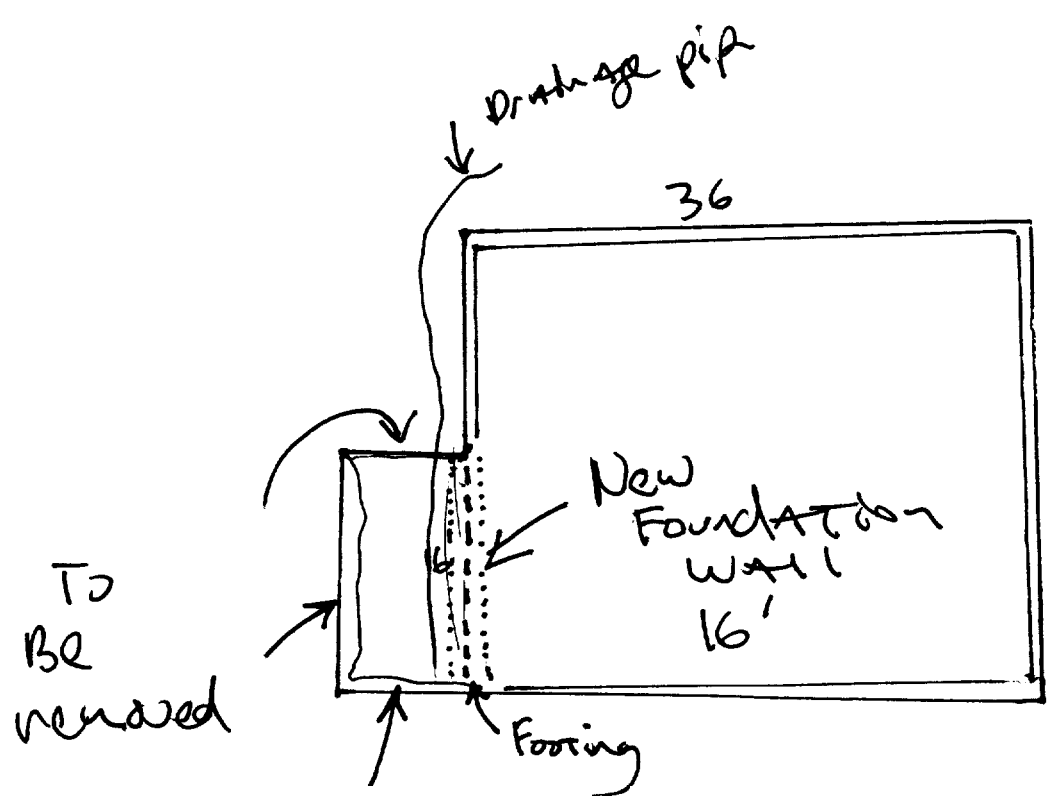

Centered

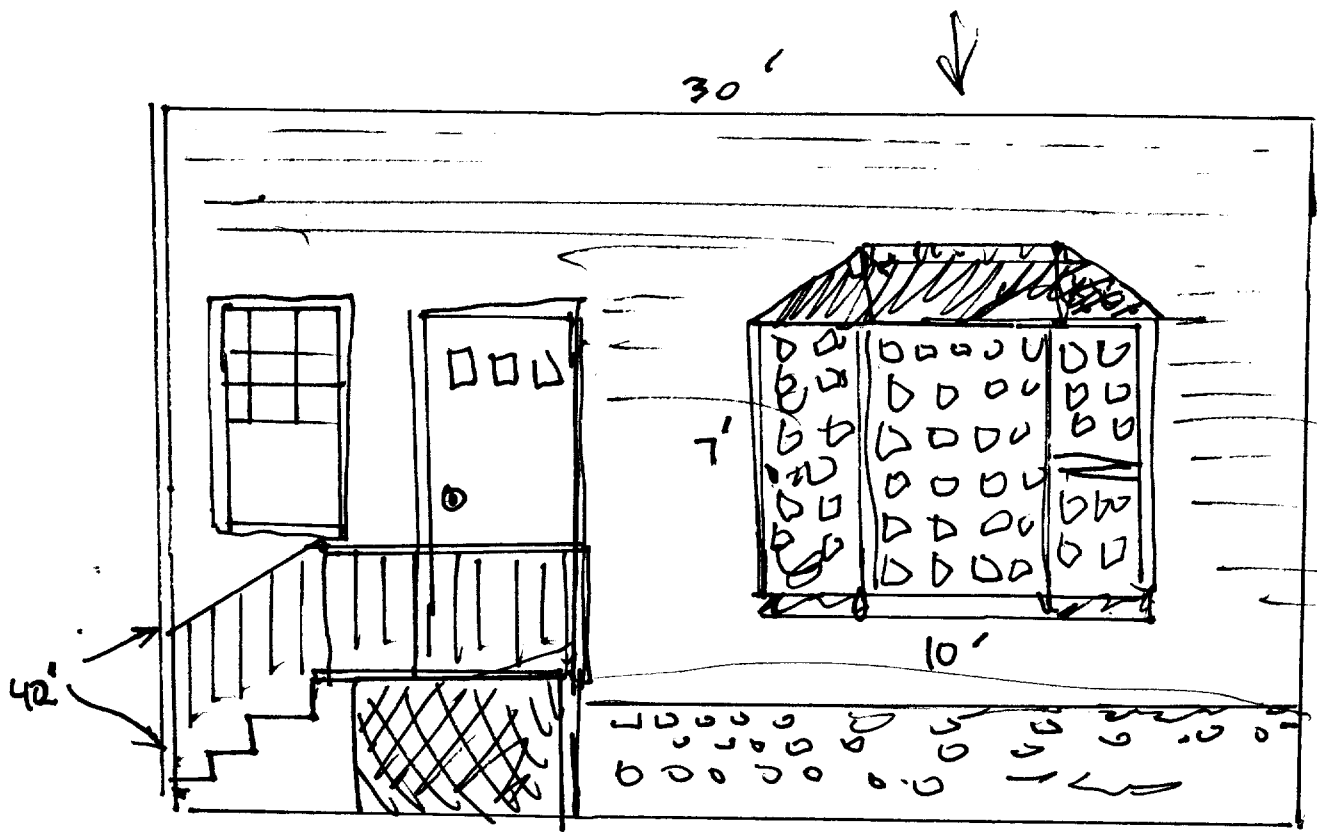

removal of porch.
 Addition of Small Stair Area & Bay window

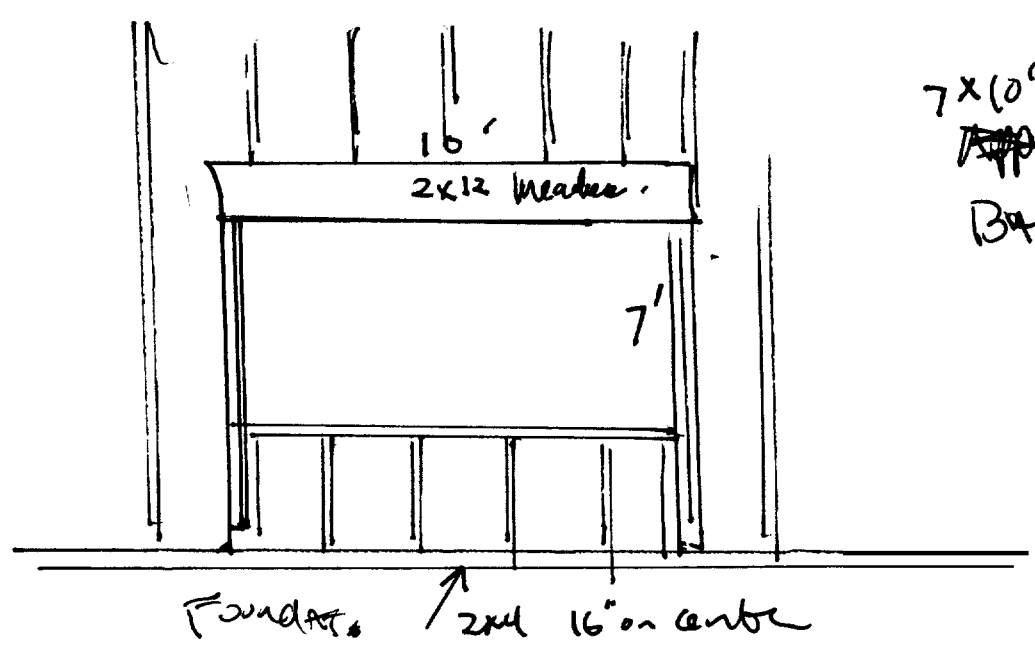
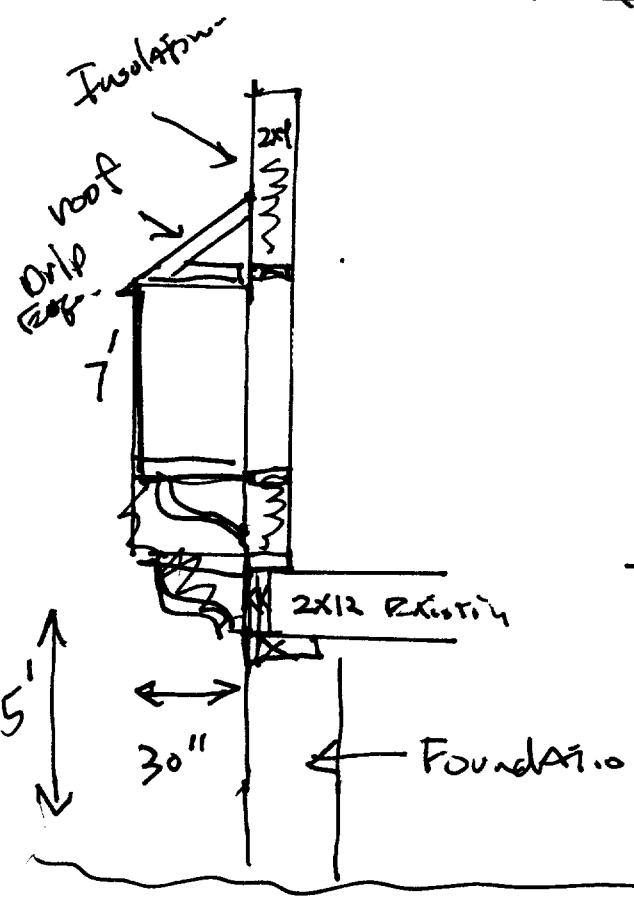

7x10' opening Bay window

Present window & Door will remain.

Bay window will be 7x10'.

