

# DISPLAY THIS CARD ON PRINCIPAL FRONTAGE OF WORK CITY OF PORTLAND

## BUILDING DEPARTMENT

# PERMIT

Permit Number: 090665

Please Read Application And Notes, If Any, Attached

This is to certify that DOYON MARYEL C /David D. Metro  
has permission to Construct Egress Stairs from the second Floor  
AT 53 NINTH ST CB# 339 N007001

provided that the person or persons, firm or corporation accepting this permit shall comply with all of the provisions of the Statutes of Maine and of the Ordinances of the City of Portland regulating the construction, maintenance and use of buildings and structures, and of the application on file in this department.

Apply to Public Works for street line and grade if nature of work requires such information.

Notification of inspection must be given and written permission procured before this building or part thereof is lathed or otherwise finished-in. 24 HOUR NOTICE IS REQUIRED.

A certificate of occupancy must be procured by owner before this building or part thereof is occupied.

**PERMIT ISSUED**

OTHER REQUIRED APPROVALS

JUN 24 2009

Department Name: CITY OF PORTLAND

Fire Dept.  
Health Dept.  
Appeal Board  
Other

*Thomas M. Maule* 6/24/09  
Director - Building & Inspection Services

**PENALTY FOR REMOVING THIS CARD**

**City of Portland, Maine - Building or Use Permit Application**

389 Congress Street, 04101 Tel: (207) 874-8703, Fax: (207) 874-8716

Permit No: 09-0665	Issue Date:	CBL: 339 N007001
-----------------------	-------------	---------------------

Location of Construction: 53 NINTH ST	Owner Name: DOYON MARYEL C	Owner Address: 409 GORHAM RD	Phone: 207-831-7914
Business Name:	Contractor Name: David Dipietro	Contractor Address: 221 Virginia Street Portland	Phone: 2078317914
Lessee/Buyer's Name	Phone:	Permit Type: Alterations - Duplex	Zone: R5

Past Use: Two Family Home	Proposed Use: Two Family Home - Construct Egress Stairs from the Second Floor.	Permit Fee: \$40.00	Cost of Work: \$1,500.00	CEO District: 5
Proposed Project Description: Construct Egress Stairs from the Second Floor.		FIRE DEPT: <input type="checkbox"/> Approved <input type="checkbox"/> Denied	INSPECTION: Use Group: R3 Type: 5B  IRC 2003  Signature: Jm 6/24/09	
		PEDESTRIAN ACTIVITIES DISTRICT (P.A.D.) Action: <input type="checkbox"/> Approved <input type="checkbox"/> Approved w/Conditions <input type="checkbox"/> Denied Signature: _____ Date: _____		

Permit Taken By: lmd	Date Applied For: 06/24/2009	<b>Zoning Approval</b>		
-------------------------	---------------------------------	------------------------	--	--

- This permit application does not preclude the Applicant(s) from meeting applicable State and Federal Rules.
- Building permits do not include plumbing, septic or electrical work.
- Building permits are void if work is not started within six (6) months of the date of issuance. False information may invalidate a building permit and stop all work..

Special Zone or Reviews	Zoning Appeal	Historic Preservation
<input type="checkbox"/> Shoreland <input type="checkbox"/> Wetland <input type="checkbox"/> Flood Zone <i>OK</i> <input type="checkbox"/> Subdivision <input type="checkbox"/> Site Plan Maj <input type="checkbox"/> Minor <input type="checkbox"/> MM <input type="checkbox"/> Date: Jm 6/24/09	<input type="checkbox"/> Variance <input type="checkbox"/> Miscellaneous <input type="checkbox"/> Conditional Use <input type="checkbox"/> Interpretation <input type="checkbox"/> Approved <input type="checkbox"/> Denied Date: _____	<input checked="" type="checkbox"/> Not in District or Landmark <input checked="" type="checkbox"/> Does Not Require Review <input type="checkbox"/> Requires Review <input type="checkbox"/> Approved <input type="checkbox"/> Approved w/Conditions <input type="checkbox"/> Denied Date: Jm 6/24/09

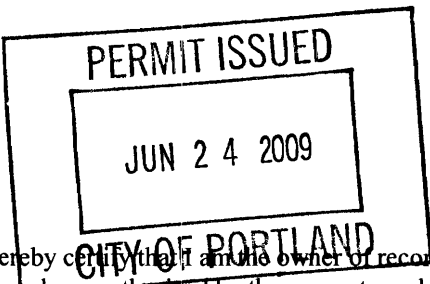

**CERTIFICATION**

I hereby certify that I am the owner of record of the named property, or that the proposed work is authorized by the owner of record and that I have been authorized by the owner to make this application as his authorized agent and I agree to conform to all applicable laws of this jurisdiction. In addition, if a permit for work described in the application is issued, I certify that the code official's authorized representative shall have the authority to enter all areas covered by such permit at any reasonable hour to enforce the provision of the code(s) applicable to such permit.

SIGNATURE OF APPLICANT	ADDRESS	DATE	PHONE
RESPONSIBLE PERSON IN CHARGE OF WORK, TITLE		DATE	PHONE

**BUILDING PERMIT INSPECTION PROCEDURES**

**Please call ~~874-8703~~ or 874-8693 (ONLY )**

**to schedule your inspections as agreed upon**

**Permits expire in 6 months, if the project is not started or ceases for 6 months.**

The Owner or their designee is required to notify the inspections office for the following inspections and provide adequate notice. Notice must be called in 48-72 hours in advance in order to schedule an inspection:

**By initializing at each inspection time, you are agreeing that you understand the inspection procedure and additional fees from a "Stop Work Order" and "Stop Work Order Release" will be incurred if the procedure is not followed as stated below.**

**A Pre-construction Meeting will take place upon receipt of your building permit.**

  X   **Final inspection required at completion of work.**

Certificate of Occupancy is not required for certain projects. Your inspector can advise you if your project requires a Certificate of Occupancy. All projects DO require a final inspection.

**If any of the inspections do not occur, the project cannot go on to the next phase, REGARDLESS OF THE NOTICE OR CIRCUMSTANCES.**

**CERIFICATE OF OCCUPANICES MUST BE ISSUED AND PAID FOR, BEFORE THE SPACE MAY BE OCCUPIED.**

  
\_\_\_\_\_

Signature of Applicant/Designee

6-24-05

Date

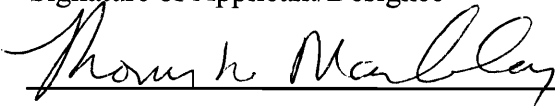
  
\_\_\_\_\_

Signature of Inspections Official

6/24/05

Date



# General Building Permit Application

If you or the property owner owes real estate or personal property taxes or user charges on any property within the City, payment arrangements must be made before permits of any kind are accepted.

Location/Address of Construction: <b>53 NINTH ST</b>		
Total Square Footage of Proposed Structure/Area	Square Footage of Lot	Number of Stories
Tax Assessor's Chart, Block & Lot Chart#      Block#      Lot# <b>JUN 24 2009</b>	Applicant *must be owner, Lessee or Buyer* Name <b>MARVEL DOYCN</b> Address <b>53 NINTH ST</b> City, State & Zip <b>PORTLAND ME</b>	Telephone:
Lessee/DBA (If Applicable)	Owner (if different from Applicant) Name Address City, State & Zip	Cost Of Work: \$ <b>1500.</b> C of O Fee: \$ _____ Total Fee: \$ _____
Current legal use (i.e. single family) <b>DUPLEX</b> Number of Residential Units _____ If vacant, what was the previous use? _____ Proposed Specific use: _____ Is property part of a subdivision? <b>NO</b> If yes, please name _____ Project description: <b>CONSTRUCT EGRESS FROM SECOND FLOOR</b>		
Contractor's name: <b>DAVID DIPIETRO</b> Address: <b>221 VIRGINIA ST</b> City, State & Zip <b>PORTLAND ME 04103</b> Telephone: _____ Who should we contact when the permit is ready: <b>DAVID</b> Telephone: <b>8317914</b> Mailing address: <b>SAMIE</b>		

Please submit all of the information outlined on the applicable Checklist. Failure to do so will result in the automatic denial of your permit.

In order to be sure the City fully understands the full scope of the project, the Planning and Development Department may request additional information prior to the issuance of a permit. For further information or to download copies of this form and other applications visit the Inspections Division on-line at [www.portlandmaine.gov](http://www.portlandmaine.gov), or stop by the Inspections Division office, room 315 City Hall or call 874-8703.

I hereby certify that I am the Owner of record of the named property, or that the owner of record authorizes the proposed work and that I have been authorized by the owner to make this application as his/her authorized agent. I agree to conform to all applicable laws of this jurisdiction. In addition, if a permit for work described in this application is issued, I certify that the Code Official's authorized representative shall have the authority to enter all areas covered by this permit at any reasonable hour to enforce the provisions of the codes applicable to this permit.

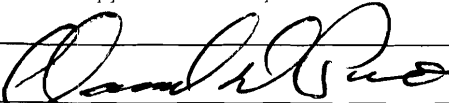
Signature:  Date: **6-24-9**

This is not a permit; you may not commence ANY work until the permit is issue

53 NINTH ST

SECOND  
FLOOR  
EGRESS

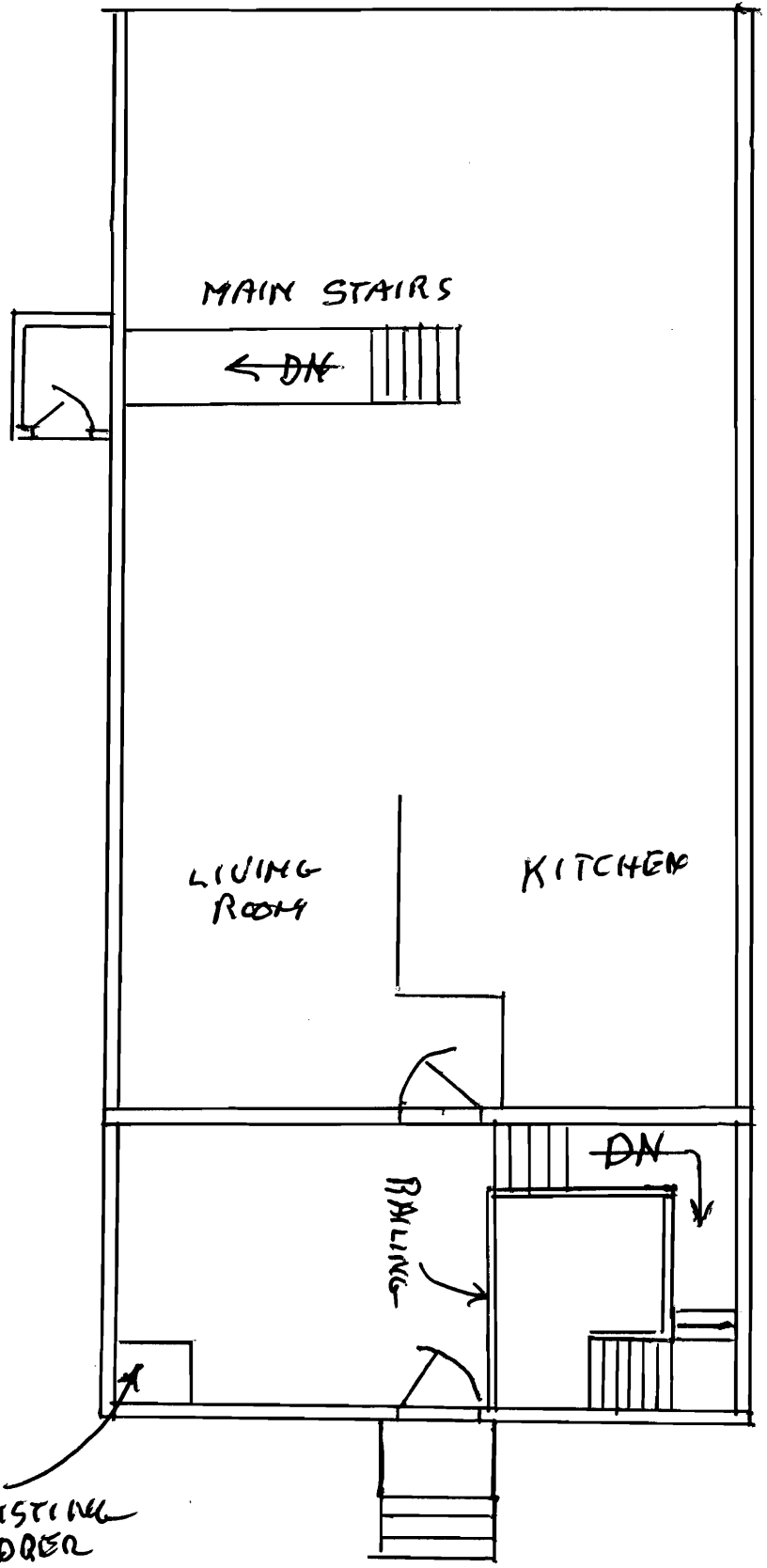

2<sup>ND</sup> FLOOR EXISTING PORCH

EXISTING  
LADDER  
FOR  
EGRESS  
TO BE CLOSED

53 NINTH ST

2<sup>ND</sup> FLOOR EGRESS

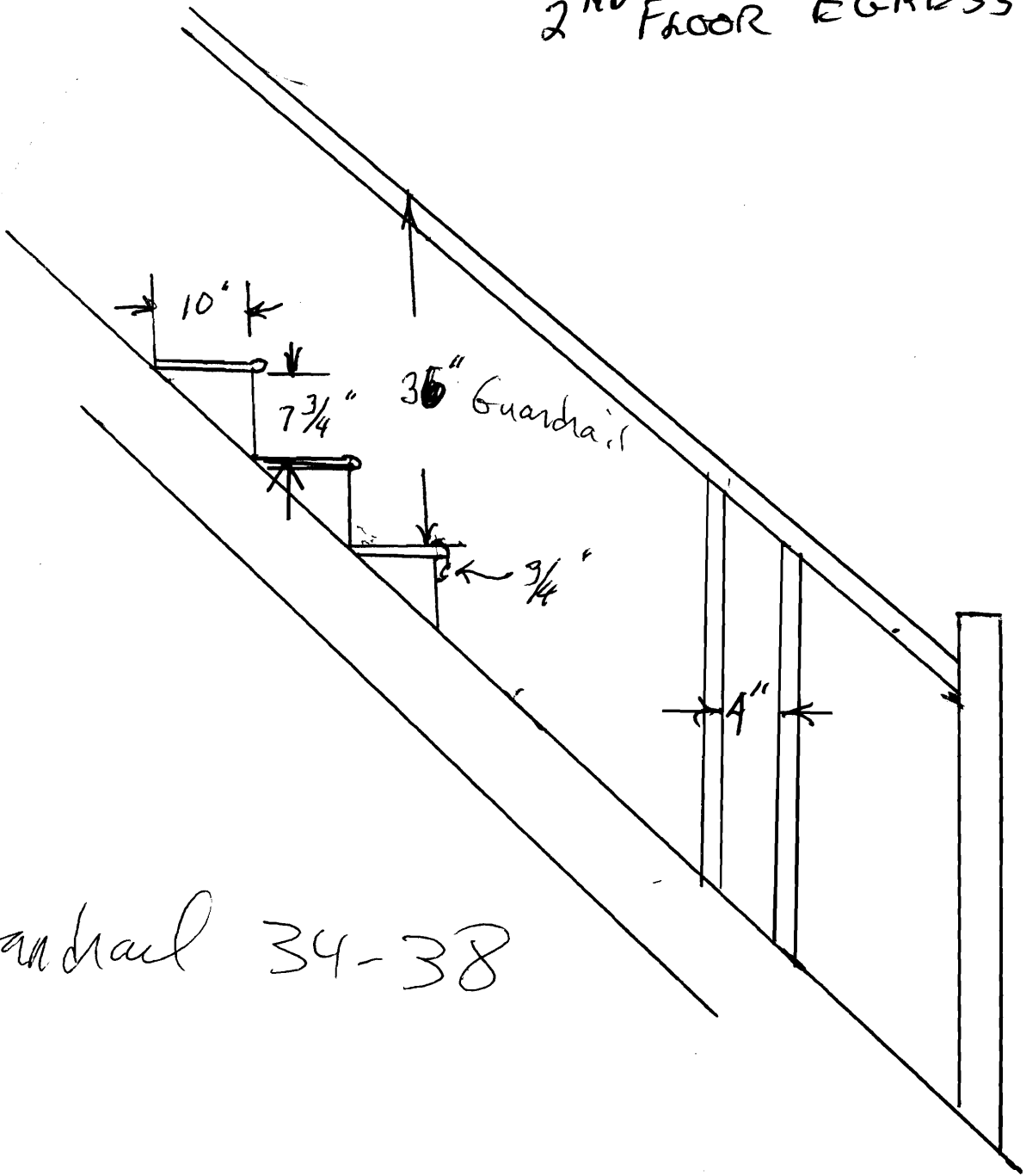

Handrail 34-38

**City of Portland, Maine - Building or Use Permit**

389 Congress Street, 04101 Tel: (207) 874-8703, Fax: (207) 874-8716

<b>Permit No:</b> 09-0665	<b>Date Applied For:</b> 06/24/2009	<b>CBL:</b> 339 N007001
------------------------------	--	----------------------------

<b>Location of Construction:</b> 53 NINTH ST	<b>Owner Name:</b> DOYON MARYEL C	<b>Owner Address:</b> 409 GORHAM RD	<b>Phone:</b> 207-831-7914
<b>Business Name:</b>	<b>Contractor Name:</b> David Dipietro	<b>Contractor Address:</b> 221 Virginia Street Portland	<b>Phone:</b> (207) 831-7914
<b>Lessee/Buyer's Name</b>	<b>Phone:</b>	<b>Permit Type:</b> Alterations - Duplex	

<b>Proposed Use:</b> Two Family Home - Construct Egress Stairs from the Second Floor.	<b>Proposed Project Description:</b> Construct Egress Stairs from the Second Floor.
--	--

**Dept:** Zoning      **Status:** Approved      **Reviewer:** Tom Markley      **Approval Date:** 06/24/2009

**Note:** **Ok to Issue:**

- 1) This is NOT an approval for an additional dwelling unit. You SHALL NOT add any additional kitchen equipment including, but not limited to items such as stoves, microwaves, refrigerators, or kitchen sinks, etc. Without special approvals.
- 2) This permit is being approved on the basis of plans submitted. Any deviations shall require a separate approval before starting that work.

**Dept:** Building      **Status:** Approved with Conditions      **Reviewer:** Tom Markley      **Approval Date:** 06/24/2009

**Note:** **Ok to Issue:**

- 1) Permit approved based on the plans submitted and reviewed w/owner/contractor, with additional information as agreed on and as noted on plans.
- 2) Separate permits are required for any electrical, plumbing, sprinkler, fire alarm or HVAC or exhaust systems. Separate plans may need to be submitted for approval as a part of this process.