

DISPLAY THIS CARD ON PRINCIPAL FRONTAGE OF WORK CITY OF PORTLAND

Please Read Application And Notes, If Any, Attached

DEPARTMENT OF BUILDING INSPECTION

PERMIT ISSUED

Permit Number: 030503

MAY 13 2003

This is to certify that Deschambault Susan/Glamour Pool

has permission to Install 14x32 inground pool

CITY OF PORTLAND

AT 62 Farragut St 339 J011001

provided that the person or persons, firm or corporation accepting this permit shall comply with all of the provisions of the Statutes of the State and of the Ordinances of the City of Portland regulating the construction, maintenance and use of buildings and structures, and of the application on file in this department.

Apply to Public Works for street line and grade if nature of work requires such information.

Notification of inspection must be given and when permission is procured before this building or part thereof is occupied or closed-in. 24 HOUR NOTICE IS REQUIRED.

A certificate of occupancy must be procured by owner before this building or part thereof is occupied.

OTHER REQUIRED APPROVALS

Fire Dept. _____
Health Dept. _____
Appeal Board _____
Other _____
Department Name

Janice Banke 5/13/03
Director - Building & Inspection Services

PENALTY FOR REMOVING THIS CARD

PERMIT ISSUED

City of Portland, Maine - Building or Use Permit Application

389 Congress Street, 04101 Tel: (207) 874-8703, Fax: (207) 874-8716

Permit No: 03-0503	Issue Date: MAY 13 2003	CBL: ¹⁶ 339 J011001
-----------------------	-----------------------------------	-----------------------------------

Location of Construction: 62 Farragut St	Owner Name: Deschambault Susan	Owner Address: 62 Farragut St CITY OF PORTLAND	Phone: 797-6922
Business Name:	Contractor Name: Glamour Pool	Contractor Address: 2 Lisbon Rd Lisbon	Phone: 2077846538
Lessee/Buyer's Name	Phone:	Permit Type: Swimming Pools	Zone: R3

Past Use: Single Family	Proposed Use: Single Family	Permit Fee: \$212.00	Cost of Work: \$27,000.00	CEO District: 1
		FIRE DEPT: <input type="checkbox"/> Approved <input type="checkbox"/> Denied INSPECTION: Use Group: R3 Type: 5B BOCA 1999 Signature: JMB 5/13/03		

Proposed Project Description: Install 14x32 inground pool w/ fence <i>& piers to hold existing deck w/ guardrails</i>	Signature: _____ PEDESTRIAN ACTIVITIES DISTRICT (P.A.D.) Action: <input type="checkbox"/> Approved <input type="checkbox"/> Approved w/Conditions <input type="checkbox"/> Denied Signature: _____ Date: _____
--	---

Permit Taken By: jmb	Date Applied For: 05/13/2003	Zoning Approval
-------------------------	---------------------------------	------------------------

<ol style="list-style-type: none"> This permit application does not preclude the Applicant(s) from meeting applicable State and Federal Rules. Building permits do not include plumbing, septic or electrical work. Building permits are void if work is not started within six (6) months of the date of issuance. False information may invalidate a building permit and stop all work.. 	Special Zone or Reviews <input type="checkbox"/> Shoreland <input type="checkbox"/> Wetland <i>approved</i> <input type="checkbox"/> Flood Zone <input type="checkbox"/> Subdivision <input type="checkbox"/> Site Plan Maj <input type="checkbox"/> Minor <input type="checkbox"/> MM <input type="checkbox"/> Date: JMB 5/13/03	Zoning Appeal <input type="checkbox"/> Variance <input type="checkbox"/> Miscellaneous <input type="checkbox"/> Conditional Use <input type="checkbox"/> Interpretation <input type="checkbox"/> Approved <input type="checkbox"/> Denied Date: _____	Historic Preservation <input checked="" type="checkbox"/> Not in District or Landmark <input type="checkbox"/> Does Not Require Review <input type="checkbox"/> Requires Review <input type="checkbox"/> Approved <input type="checkbox"/> Approved w/Conditions <input type="checkbox"/> Denied Date: JMB
---	--	---	---

CERTIFICATION

I hereby certify that I am the owner of record of the named property, or that the proposed work is authorized by the owner of record and that I have been authorized by the owner to make this application as his authorized agent and I agree to conform to all applicable laws of this jurisdiction. In addition, if a permit for work described in the application is issued, I certify that the code official's authorized representative shall have the authority to enter all areas covered by such permit at any reasonable hour to enforce the provision of the code(s) applicable to such permit.

SIGNATURE OF APPLICANT ADDRESS DATE PHONE

RESPONSIBLE PERSON IN CHARGE OF WORK, TITLE DATE PHONE

5/15/03 - No excavation yet. - Pool perimeter is staked out - distance from principal structure to closest pin is only 9' 8 1/2" - must be 10' -

Left "Do Not Proceed" tag
Also: Pre-existing deck does not show on plans - Deck has been reconfigured w/ new footings & vertical supports - Permit should be required for this. @

5/15/03 Talked w/ owner - They will relocate pool & apply for permit for re-building of deck @

5/21/03 - Owner verified pool set back ^{to house} via phone
Contractor starting - Inspector check again on site when out for sona tubes. JB

5/27/03 Set Backs ok, Sona tubes ok. AM

City of Portland, Maine - Building or Use Permit

389 Congress Street, 04101 Tel: (207) 874-8703, Fax: (207) 874-8716

Permit No: 03-0503	Date Applied For: 05/13/2003	CBL: 339 J011001
------------------------------	--	----------------------------

Location of Construction: 62 Farragut St	Owner Name: Deschambault Susan	Owner Address: 62 Farragut St	Phone: () 797-6922
Business Name:	Contractor Name: Glamour Pool	Contractor Address: 2 Lisbon Rd Lisbon	Phone (207) 784-6538
Lessee/Buyer's Name	Phone:	Permit Type: Swimming Pools	

Proposed Use: Single Family	Proposed Project Description: Install 14x32 inground pool w/ fence
---------------------------------------	--

Dept: Zoning	Status: Approved	Reviewer: Jeanine Bourke	Approval Date: 05/13/2003
Note: 1) Separate permits shall be required for any new signage			Ok to Issue: <input checked="" type="checkbox"/>
Dept: Building	Status: Approved	Reviewer: Jeanine Bourke	Approval Date: 05/13/2003
Note: 1) Separate permits are required for electrical pump installation			Ok to Issue: <input checked="" type="checkbox"/>

Pool Installation/Construction Permit Application

If you or the property owner owes real estate or personal property taxes or user charges on any property within the City, payment arrangements must be made before permits of any kind are accepted.

Location/Address of Construction: <u>62 Farragut</u>		
Total Square Footage of Proposed Structure <u>448</u>	Square Footage of Lot <u>150 x 215 = 30,948</u>	
Tax Assessor's Chart, Block & Lot Chart# <u>339</u> Block# <u>J</u> Lot# <u>11 to 16</u>	Owner: <u>Susan Dechambault</u>	Telephone: <u>797-6922</u>
Lessee/Buyer's Name (If Applicable)	Applicant name, address & telephone: <u>Dawson D Moulton</u> <u>62 FARRAGUT ST.</u> <u>Portland Me 04103</u> <u>7976922</u>	Cost Of Work: \$ <u>27,000</u> Fee: \$ <u>212.00</u>
Dimensions of pool: <u>14' x 32'</u> Above or <u>below</u> ground: _____		
Dimensions of decking and/or any platforms, sheds, or other structures: <u>3' wide Concrete Platform</u>		
Contractor's name, address & telephone: <u>Glamour Pools</u>		
Whom should we contact when the permit is ready: <u>Dawson D Moulton</u>		
Mailing address: <u>62 FARRAGUT ST - PORTLAND MAINE</u> <u>04103</u>		
We will contact you by phone when the permit is ready. You must come in and pick up the permit and review the requirements before starting any work, with a Plan Reviewer. A stop work order will be issued and a \$100.00 fee if any work starts before the permit is picked up. PHONE: _____		

IF THE REQUIRED INFORMATION IS NOT INCLUDED IN THE SUBMISSIONS THE PERMIT WILL BE AUTOMATICALLY DENIED AT THE DISCRETION OF THE BUILDING/PLANNING DEPARTMENT, WE MAY REQUIRE ADDITIONAL INFORMATION IN ORDER TO APPROVE THIS PERMIT.

I hereby certify that I am the Owner of record of the named property, or that the owner of record authorizes the proposed work and that I have been authorized by the owner to make this application as his/her authorized agent. I agree to conform to all applicable laws of this jurisdiction. In addition, if a permit for work described in this application is issued, I certify that the Code Official's authorized representative shall have the authority to enter all areas covered by this permit at any reasonable hour to enforce the provisions of the codes applicable to this permit.

Signature of applicant: <u>Dawson Moulton</u>	Date: <u>5-</u>
---	-----------------

**This is NOT a permit; you may not commence ANY work until the permit is issued.
If you are in a Historic District you may be subject to additional permitting
and fees with the Planning Department on the 4th floor of City Hall**

In Ground Swimming Pool

← FARRAGUT ST →
← 150 FT →

R 3 Zone
Pools need to be
min 10' from
Property Lines
&
Principal Structure

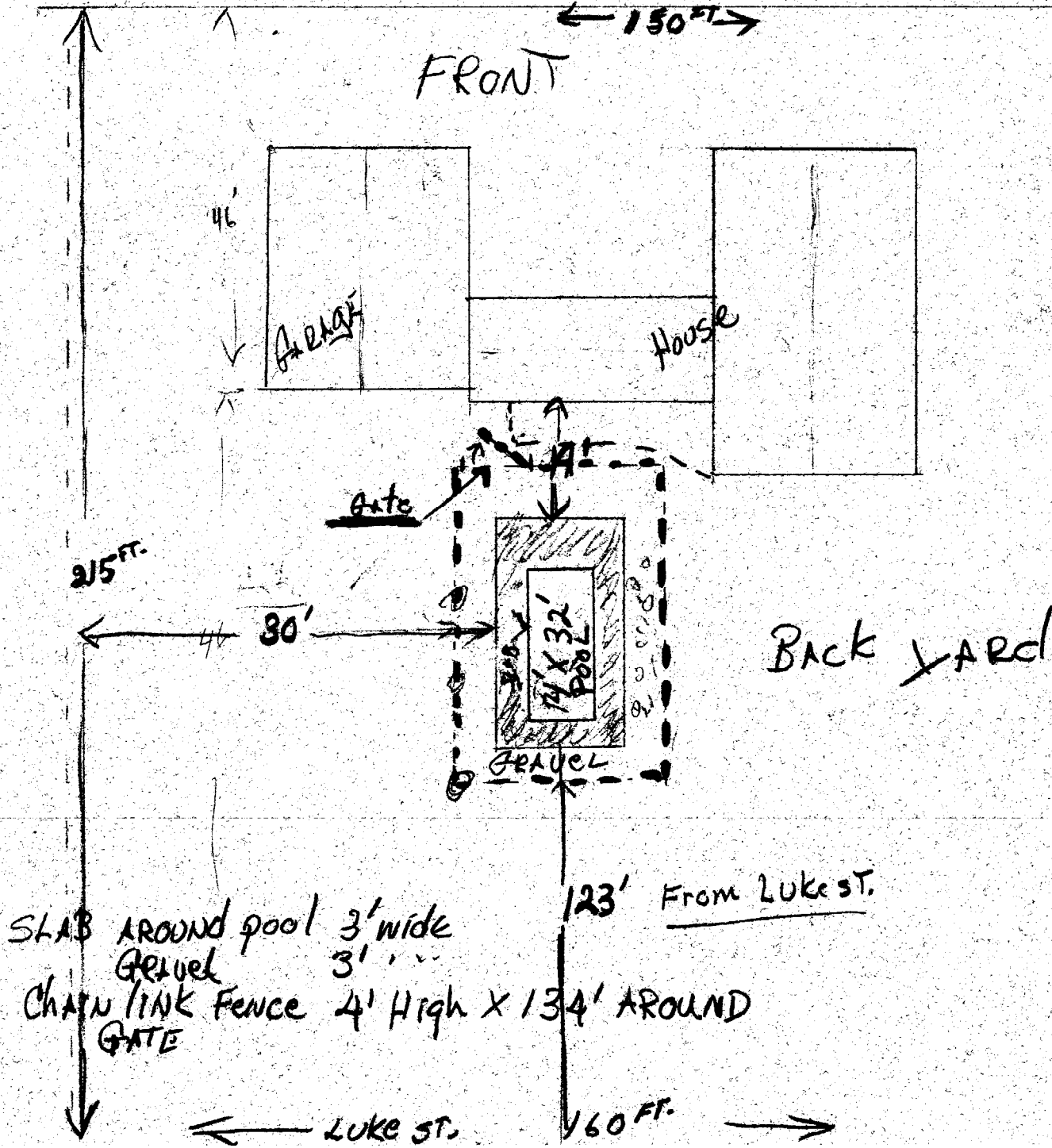

SLAB AROUND pool 3' wide
GRVEL 3' ...
CHAIN LINK Fence 4' High X 134' AROUND
GATE

339-J-11

03-0503

62 FAERAGUT ST.

874-8703

Jeanne Bouke

Back House

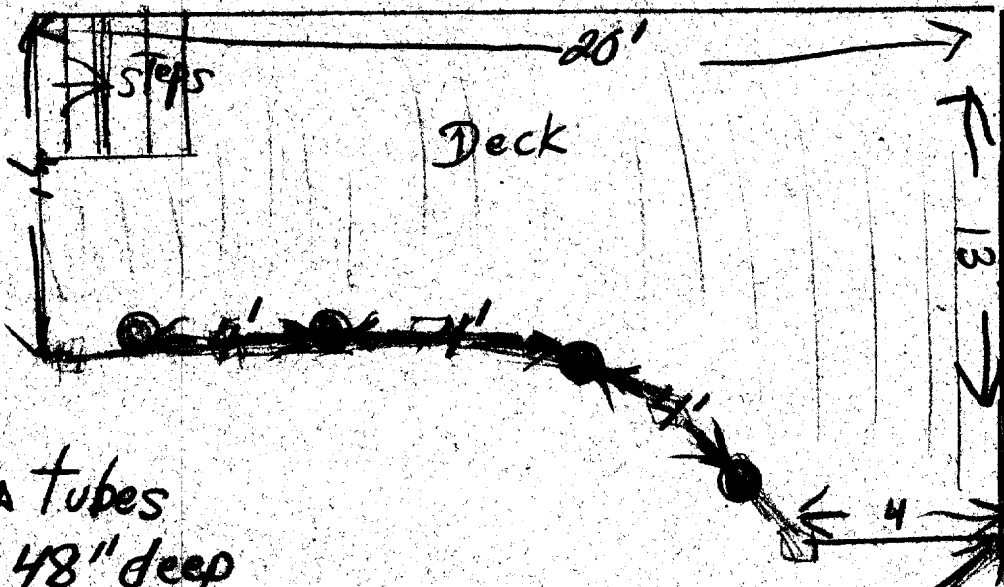

④ Sona Tubes
8" x 48" deep

Insp
Kevin Carroll

Pool

Guardrails to be
36" balusters 24" space

DEPT. OF BUILDING INSPECTION
CITY OF PORTLAND, ME

MAY 19 2003

RECEIVED

This page contains a detailed description of the Parcel ID you selected. Press the **New Search** button at the bottom of the screen to submit a new query.

Current Owner Information

Card Number	1 of 1
Parcel ID	339 J011001
Location	62 FARRAGUT ST
Land Use	SINGLE FAMILY
Owner Address	DESCHAMBAULT SUSAN 62 FARRAGUT ST PORTLAND ME 04103
Book/Page	12605/173
Legal	339-J-11 TO 16 339-J- 38 TO 43 LUKE ST FARRAGUT ST 58-68 30948 SF

Valuation Information

Land	Building	Total
\$39,900	\$78,020	\$117,920

Property Information

Year Built 1920	Style Old Style	Story Height 1	Sq. Ft. 1454	Total Acres 0.71		
Bedrooms 3	Full Baths 1	Half Baths	Total Rooms 7	Attic Full Fin./wh	Basement Full	

Outbuildings

Type	Quantity	Year Built	Size	Grade	Condition
SHED-FRAME	1	1980	8X12	C	A
GARAGE-WD/CB	1	1995	26X28	C	A

Sales Information

Date	Type	Price	Book/Page
09/26/1996	LAND		12741-168
07/09/1996	LAND	\$1,000	12605-173

Picture and Sketch

[Picture](#) [Sketch](#)

[Click here](#) to view Tax Roll Information.

Any information concerning tax payments should be directed to the Treasury office at 874-8490 or [e-mailed](#).

New Search!



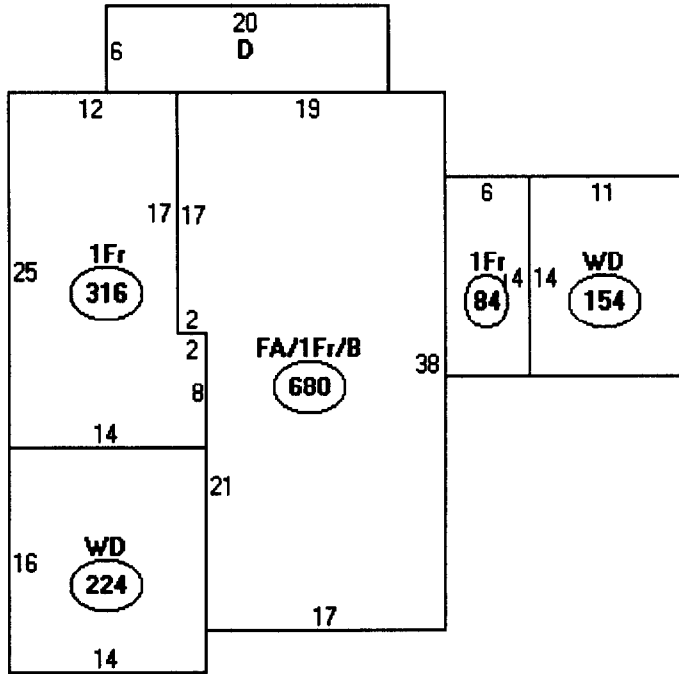

Descriptor/Area

- A: FA/1Fr/B
680 sqft
- B: WD
224 sqft
- C: 1Fr
316 sqft
- D: EP
120 sqft
- E: 1Fr
84 sqft
- F: WD
154 sqft

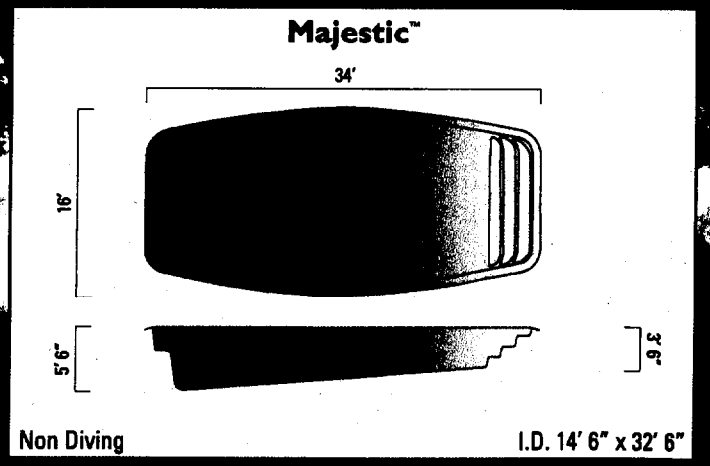
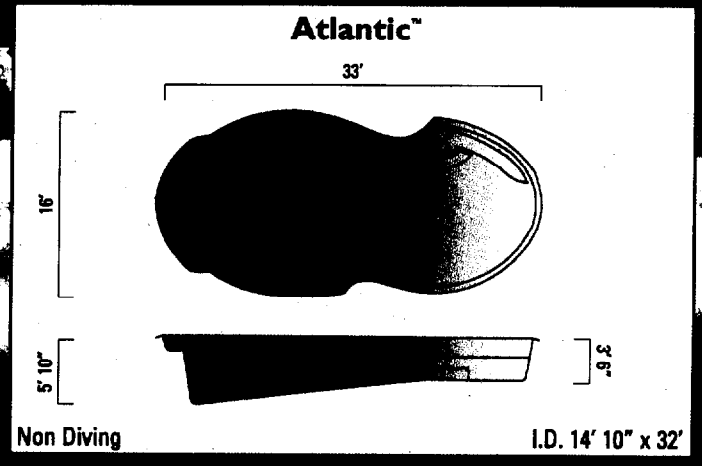
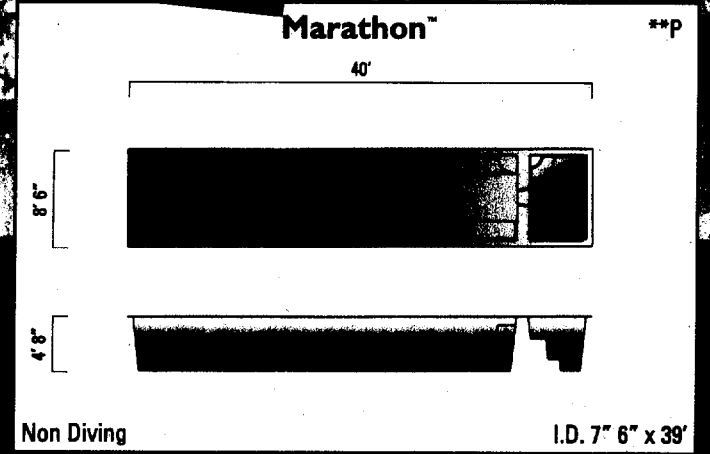
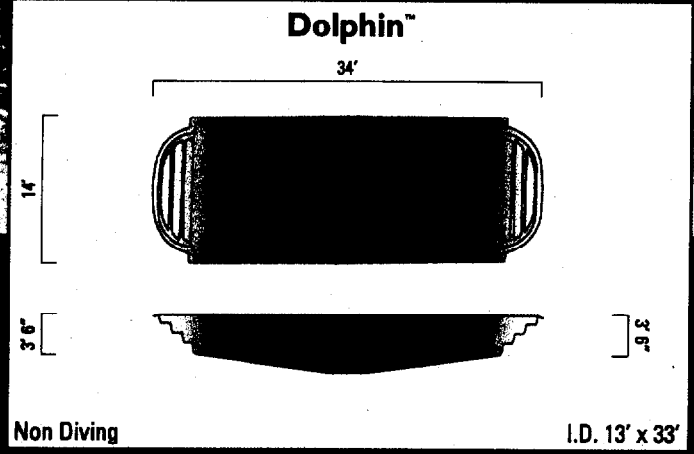
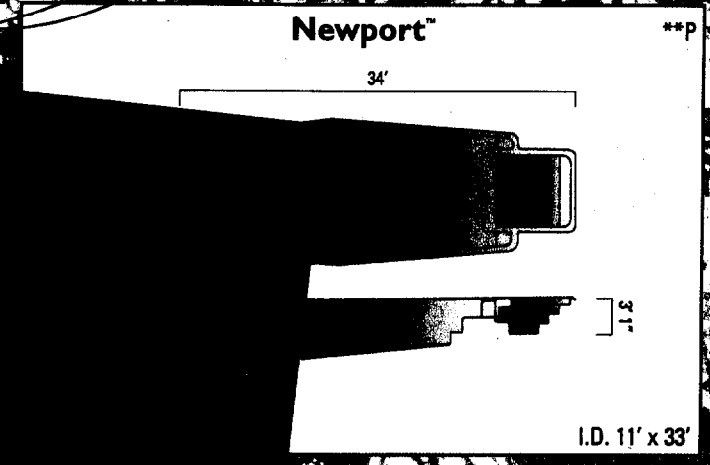
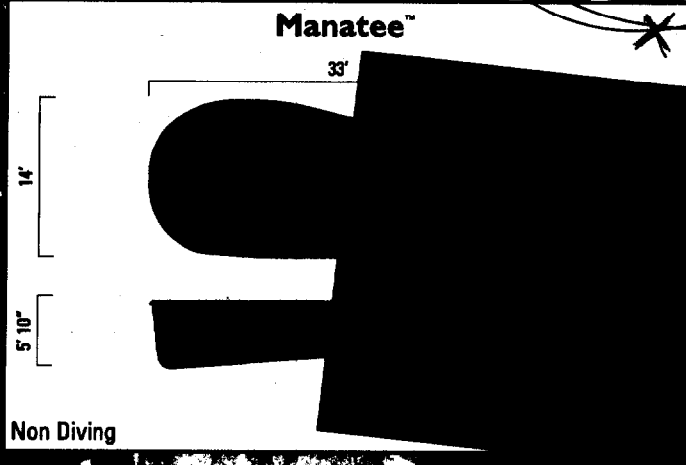
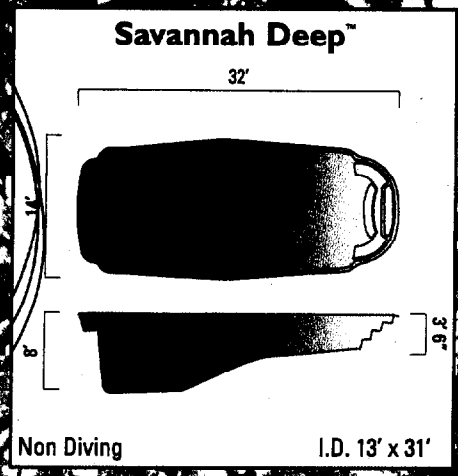
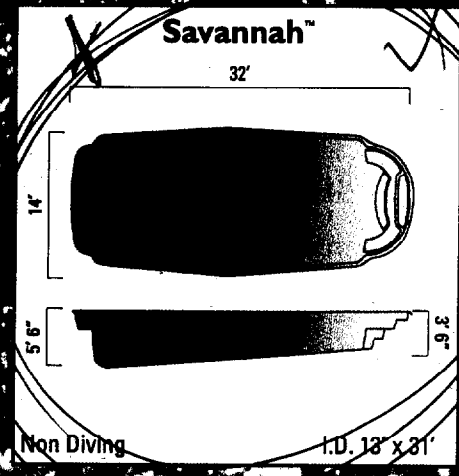
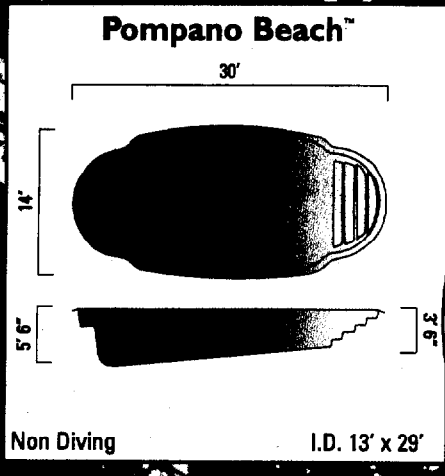

ACCESS GATE OR PEDESTRIAN ACCESS GATE

Self closing
Self latching
Accomodate a lock

$\frac{1}{2}$ " MAXIMUM OPENING WITHIN
18" OF THE RELEASE
MECHANISM

3" MINIMUM
BELOW TOP OF GATE

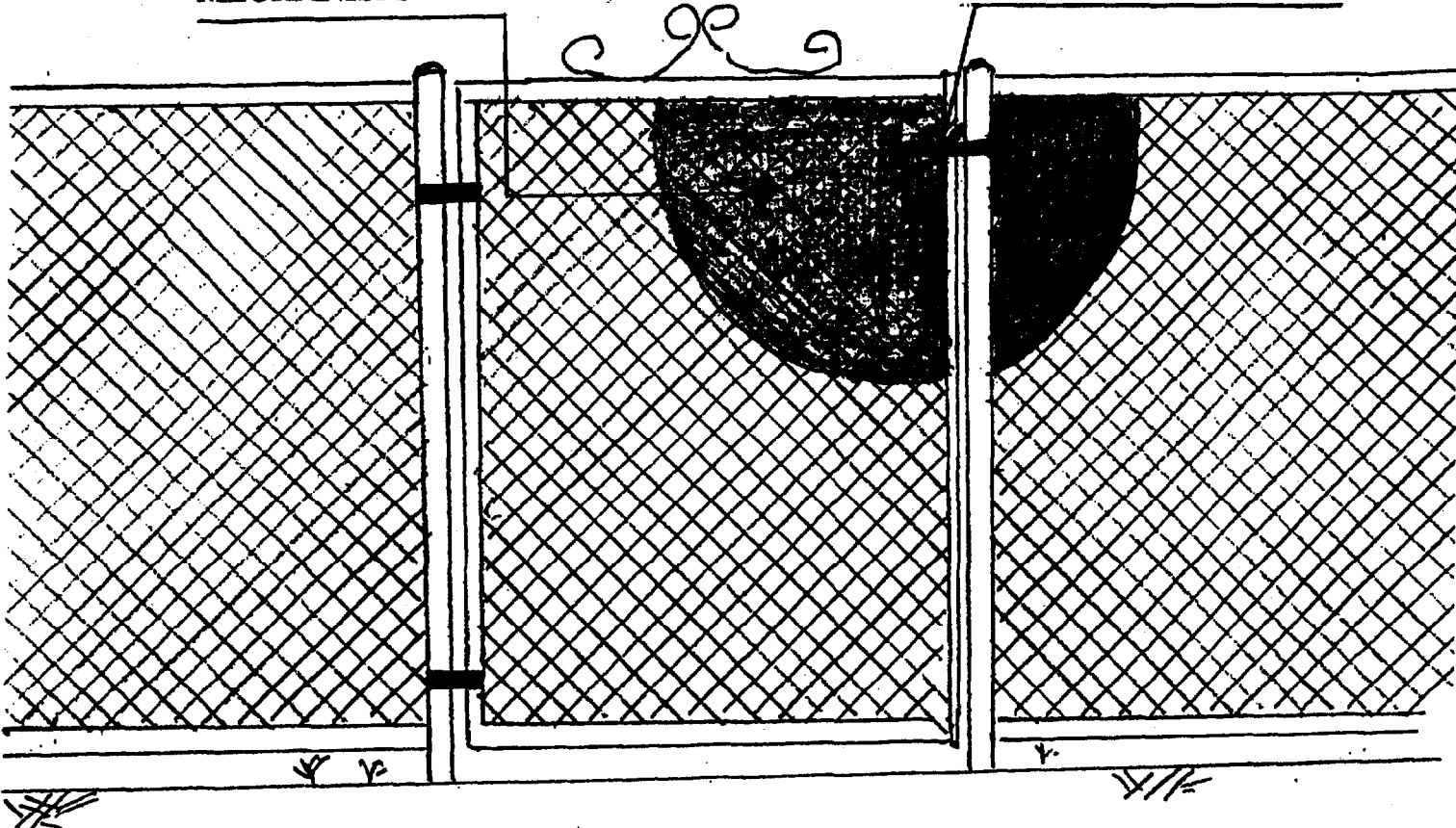

INSIDE POOL AREA ONLY

SECTION 421.10.1, ITEM 8 (a) and (b)

ELEVATION

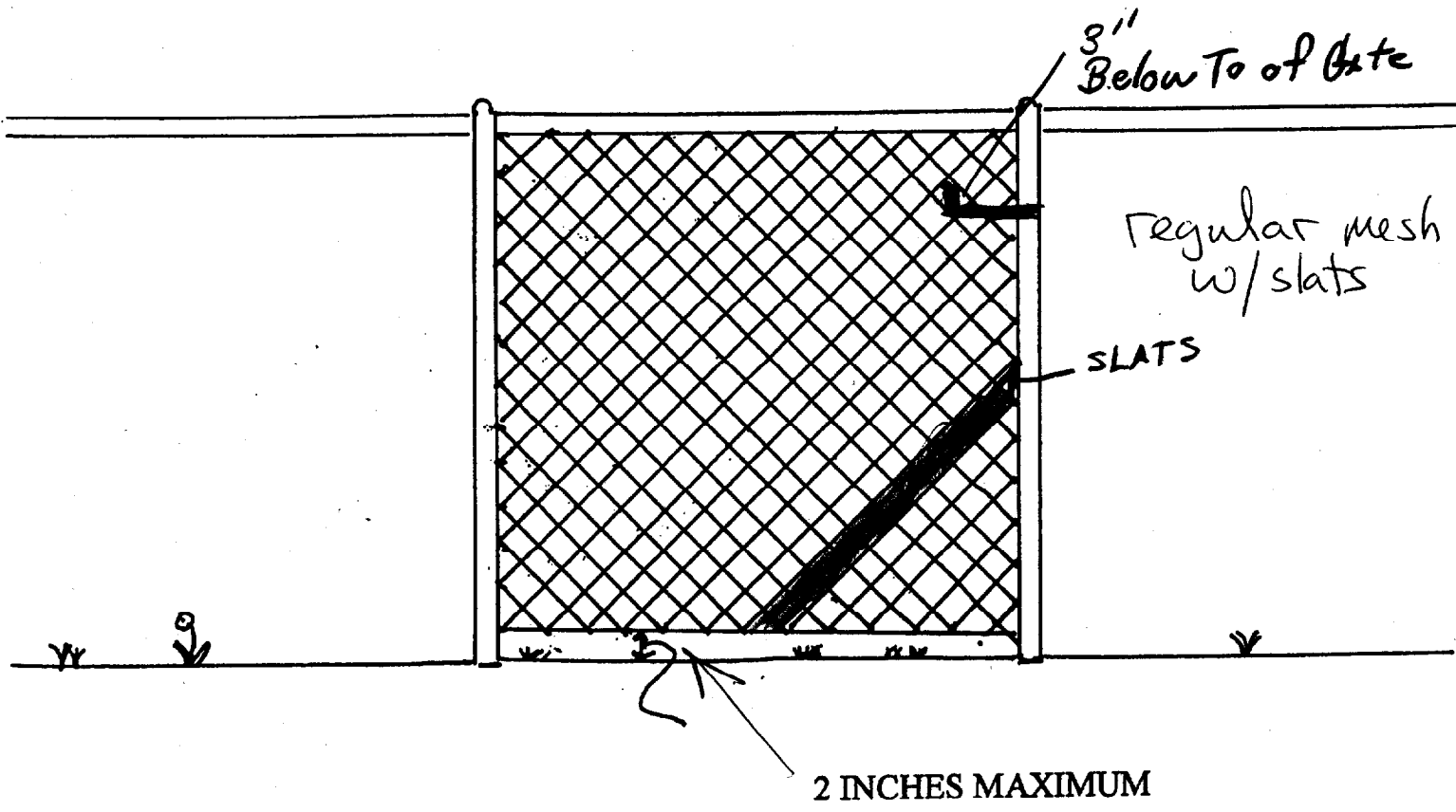

OUTSIDE OF THE POOL ENCLOSURE

SECTION 421.10.1, ITEM 1

ELEVATION

BUILDING PERMIT INSPECTION PROCEDURES

Please call 874-8703 or ~~874-8693~~ to schedule your inspections as agreed upon

Permits expire in 6 months, if the project is not started or ceases for 6 months.

The Owner or their designee is required to notify the inspections office for the following inspections and provide adequate notice. Notice must be called in 48-72 hours in advance in order to schedule an inspection:

By initializing at each inspection time, you are agreeing that you understand the inspection procedure and additional fees from a "Stop Work Order" and "Stop Work Order Release" will be incurred if the procedure is not followed as stated below.

~~JB~~ ~~Pre-construction Meeting:~~ Must be scheduled with your inspection team upon receipt of this permit. Jay Reynolds, Development Review Coordinator at 874-8632 must also be contacted at this time, before any site work begins on any project other than single family additions or alterations.

- Footing/Building Location Inspection: ^{D19} Prior to pouring concrete
- ~~NA~~ ~~Re-Bar Schedule Inspection:~~ Prior to pouring concrete
- ~~NA~~ ~~Foundation Inspection:~~ Prior to placing ANY backfill
- ~~NA~~ Framing/Rough Plumbing/Electrical: Prior to any insulating or drywalling
- Final Certificate of Occupancy: Prior to any occupancy of the structure or use. NOTE: ~~There is a \$75.00 fee per inspection at this point.~~

Certificate of Occupancy is not required for certain projects. Your inspector can advise you if your project requires a Certificate of Occupancy. All projects DO require a final inspection

If any of the inspections do not occur, the project cannot go on to the next phase, REGARDLESS OF THE NOTICE OR CIRCUMSTANCES.

~~NA~~ **CERIFICATE OF OCCUPANICES MUST BE ISSUED AND PAID FOR, BEFORE THE SPACE MAY BE OCCUPIED**

Rausan Newton
Signature of applicant/designee

Date

James Rount
Signature of Inspections Official

Date

CBL: 339-J-11

Building Permit #:

03-0503



CITY OF PORTLAND, MAINE
Department of Building Inspections

May 13 2003

Received from Susan Dechambault

Location of Work 62 Farragat

Cost of Construction \$ 27,000

Permit Fee \$ 212.00

Building (IL) Plumbing (I5) Electrical (I2) Site Plan (U2)

Other _____

CBL: 339-J-11-16

Check #: cash Total Collected \$ 212.00

THIS IS NOT A PERMIT

No work is to be started until PERMIT CARD is actually posted upon the premises. Acceptance of fee is no guarantee that permit will be granted. PRESERVE THIS RECEIPT. In case permit cannot be granted the amount of the fee will be refunded upon return of the receipt less \$10.00 or 10% whichever is greater.

WHITE - Applicant's Copy
YELLOW - Office Copy
PINK - Permit Copy