

**City of Portland, Maine - Building or Use Permit Application**

389 Congress Street, 04101 Tel: (207) 874-8703, Fax: (207) 874-8716

Permit No: 06-1800	Issue Date:	CBL: <del>336-027-24</del> * 336 F025001
-----------------------	-------------	---

Location of Construction: 0 BRAINTREE ST (#37-43)	Owner Name: HOME SWEET HOME APARTME	Owner Address: 49 NORTHERN OAKS DR	Phone:
Business Name:	Contractor Name: Wayne Hinckley	Contractor Address: 49 Northern Oakes Raymond	Phone: 2078318505
Lessee/Buyer's Name	Phone:	Permit Type: Single Family	Zone: R2

Past Use: Vacant Lot	Proposed Use: Single Family 28' x 32' 2 story house w/ attached garage	Permit Fee: \$1,345.00	Cost of Work: \$125,000.00	CEO District: 5
Proposed Project Description: 28' x 32' 2 story house w/ attached garage		FIRE DEPT: <input type="checkbox"/> Approved <input type="checkbox"/> Denied	INSPECTION: Use Group: Type:	
		Signature:	Signature:	
PEDESTRIAN ACTIVITIES DISTRICT (P.A.D.)				
Action: <input type="checkbox"/> Approved <input type="checkbox"/> Approved w/Conditions <input type="checkbox"/> Denied				
		Signature:	Date:	

Permit Taken By: dmartin	Date Applied For: 12/19/2006	<b>Zoning Approval</b>		
<ol style="list-style-type: none"> <li>This permit application does not preclude the Applicant(s) from meeting applicable State and Federal Rules.</li> <li>Building permits do not include plumbing, septic or electrical work.</li> <li>Building permits are void if work is not started within six (6) months of the date of issuance. False information may invalidate a building permit and stop all work..</li> </ol>	<b>Special Zone or Reviews</b> <input type="checkbox"/> Shoreland <i>N/A</i> <input type="checkbox"/> Wetland <i>N/A</i> <input type="checkbox"/> Flood Zone <i>panel 1-ZONE C</i> <input type="checkbox"/> Subdivision <input checked="" type="checkbox"/> Site Plan <i>2006-0240</i> Maj <input type="checkbox"/> Minor <input type="checkbox"/> MM <input checked="" type="checkbox"/>	<b>Zoning Appeal</b> <input type="checkbox"/> Variance <input type="checkbox"/> Miscellaneous <input type="checkbox"/> Conditional Use <input type="checkbox"/> Interpretation <input type="checkbox"/> Approved <input type="checkbox"/> Denied	<b>Historic Preservation</b> <input checked="" type="checkbox"/> Not in District or Landmark <input type="checkbox"/> Does Not Require Review <input type="checkbox"/> Requires Review <input type="checkbox"/> Approved <input type="checkbox"/> Approved w/Conditions <input type="checkbox"/> Denied <i>AM</i>	
	Date:	Date:	Date:	

# WITHDRAW

**CERTIFICATION**

I hereby certify that I am the owner of record of the named property, or that the proposed work is authorized by the owner of record and that I have been authorized by the owner to make this application as his authorized agent and I agree to conform to all applicable laws of this jurisdiction. In addition, if a permit for work described in the application is issued, I certify that the code official's authorized representative shall have the authority to enter all areas covered by such permit at any reasonable hour to enforce the provision of the code(s) applicable to such permit.

SIGNATURE OF APPLICANT	ADDRESS	DATE	PHONE
RESPONSIBLE PERSON IN CHARGE OF WORK, TITLE		DATE	PHONE

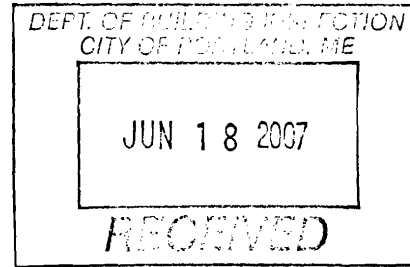

380 US Route One  
Falmouth Maine 04105  
Tel. 207 781 5242  
Fax 207.781.4245

June 18, 2007  
File: 04103

Ms. Ann Machado  
CITY OF PORTLAND  
389 Congress Street  
Portland, ME 04101

RE: BRAINTREE STREET HOUSE LOT

Dear Ann:

This letter is to notify you that Wayne Hinckley of Home Sweet Home Apartments, LLC, is withdrawing the application for two single family house lots (submitted to the City on December 18, 2006), and he is submitting a new building permit application for only one single family house.

As you recall, Mr. Hinckley has 21,000 square feet of land on seven existing lots of record at the end of Braintree Street. The prior applications submitted were for two single family house lots, with road and utility improvements to Braintree Street. Since the cost of improving Braintree Street to current City standards, along with installing approximately 450 feet of public sewer line ultimately proved to be too expensive for this project, Mr. Hinckley has chosen to pursue just one single family house at this time. He is creating a second 10,000 square foot lot for future use, which meets the R-2 zone standards for minimum lot size. There are no current development plans for this lot. If a house is to be built on Lot 2 at a later date, road, sewer, and water utility improvements will be need to be reviewed and approved by the City.

Enclosed is a document describing the limits of Braintree Street that the City has accepted as a public street. This information is also shown on the enclosed plan, and you will see that the proposed Lot 1 has 60 feet of frontage on the publicly-accepted portion of Braintree Street. Since only 50 feet of street frontage is required, we believe no other improvements to Braintree Street are required. The water main will be extended approximately 110 feet per Portland Water District regulations.

We have shown an onsite subsurface wastewater disposal system to service Lot 1. The lot is located more than 200 feet away from a public sewer line, so on site septic systems are allowed per City ordinance. An HHE-200 form is enclosed for approval.

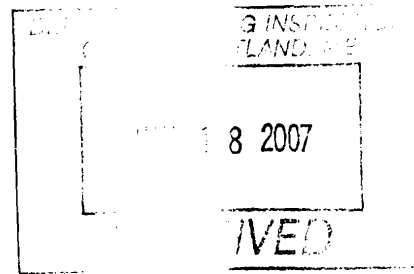

Ms. Ann Machado  
CITY OF PORTLAND  
June 18, 2007  
Page 2

We would greatly appreciate you notifying Barbara Barhydt in Planning and Mike Farmer at the Public Works Department of this change. We look forward to issuance of the building permit for Lot 1. Thank you very much in advance for your consideration.

Sincerely,

PINKHAM & GREER

A handwritten signature in black ink that reads "Mark R. Bergeron". The signature is written in a cursive style.

Mark R. Bergeron, P.E.

MRB/s

Enclosures

C: Wayne Hinckley



**PINKHAM & GREER**

CONSULTING ENGINEERS

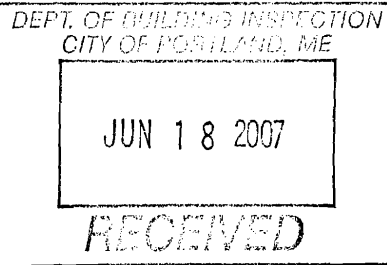

380 US Route One  
Falmouth, Maine 04105  
Tel. 207.781.5242  
Fax 207.781.4245

June 18, 2007  
File: 04103

Ms. Ann Machado  
CITY OF PORTLAND  
389 Congress Street  
Portland, ME 04101

RE: BRAINTREE STREET HOUSE LOT

Dear Ann:

This letter is to notify you that Wayne Hinckley of Home Sweet Home Apartments, LLC, is withdrawing the application for two single family house lots (submitted to the City on December 18, 2006), and he is submitting a new building permit application for only one single family house.

As you recall, Mr. Hinckley has 21,000 square feet of land on seven existing lots of record at the end of Braintree Street. The prior applications submitted were for two single family house lots, with road and utility improvements to Braintree Street. Since the cost of improving Braintree Street to current City standards, along with installing approximately 450 feet of public sewer line ultimately proved to be too expensive for this project, Mr. Hinckley has chosen to pursue just one single family house at this time. He is creating a second 10,000 square foot lot for future use, which meets the R-2 zone standards for minimum lot size. There are no current development plans for this lot. If a house is to be built on Lot 2 at a later date, road, sewer, and water utility improvements will be need to be reviewed and approved by the City.

Enclosed is a document describing the limits of Braintree Street that the City has accepted as a public street. This information is also shown on the enclosed plan, and you will see that the proposed Lot 1 has 60 feet of frontage on the publicly-accepted portion of Braintree Street. Since only 50 feet of street frontage is required, we believe no other improvements to Braintree Street are required. The water main will be extended approximately 110 feet per Portland Water District regulations.

We have shown an onsite subsurface wastewater disposal system to service Lot 1. The lot is located more than 200 feet away from a public sewer line, so on site septic systems are allowed per City ordinance. An HHE-200 form is enclosed for approval.

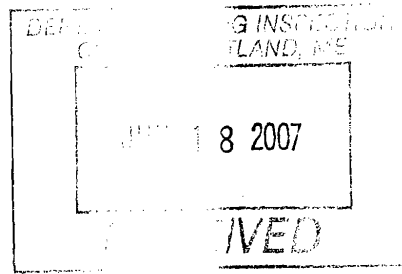

Ms. Ann Machado  
CITY OF PORTLAND  
June 18, 2007  
Page 2

We would greatly appreciate you notifying Barbara Barhydt in Planning and Mike Farmer at the Public Works Department of this change. We look forward to issuance of the building permit for Lot 1. Thank you very much in advance for your consideration.

Sincerely,

PINKHAM & GREER

A handwritten signature in black ink that reads "Mark R. Bergeron". The signature is written in a cursive, flowing style.

Mark R. Bergeron, P.E.

MRB/s

Enclosures

C: Wayne Hinckley



# General Building Permit Application

If you or the property owner owes real estate or personal property taxes or user charges on any property within the City, payment arrangements must be made before permits of any kind are accepted.

Location/Address of Construction: <u>31-4/ BRAINTREE STREET (LOT 1)</u>		
Total Square Footage of Proposed Structure <b>1,792 SF ±</b>		Square Footage of Lot <b>10,500 SF</b>
Tax Assessor's Chart, Block & Lot Chart#      Block#      Lot# <b>336            F            25</b>	Owner: <b>HOME SWEET HOME APARTMENTS, LLC</b>	Telephone: <b>207 831-8505</b>
Lessee/Buyer's Name (If Applicable) <b>—</b>	Applicant name, address & telephone: <b>HOME SWEET HOME APARTMENTS, LLC 49 NORTHERN OAKS DR, RAYMOND ME 04071</b>	Cost Of Work: \$ <u>125,000</u> Bldg Fee Fee: \$ <u>1270.00</u> C of O C of O Fee: \$ <u>75.00</u>
Current Specific use: <u>VACANT</u>	If vacant, what was the previous use? <u>VACANT</u>	<u>Site 300.00</u>
Proposed Specific use: <u>SINGLE FAMILY DETACHED HOME</u>		
Project description: <u>ONE SINGLE FAMILY DETACHED HOME</u>		<u>1,645.00</u>
<u>28' x 32' 1 car attached garage 12 1/2 x 20 1/2</u> <u>1 1/2 baths</u>		
Contractor's name, address & telephone: <u>WAYNE HINCKLEY, 49 NORTHERN OAKS DR, 207-831-8505 RAYMOND ME 04071</u>		
Who should we contact when the permit is ready: <u>WAYNE HINCKLEY</u>		
Mailing address: <u>49 NORTHERN OAKS DR RAYMOND ME 04071</u>		Phone: <u>207 831-8505</u> <u>Call XX</u>

Please submit all of the information outlined in the Commercial Application Checklist.  
Failure to do so will result in the automatic denial of your permit.

In order to be sure the City fully understands the full scope of the project, the Planning and Development Department may request additional information prior to the issuance of a permit. For further information visit us on-line at [www.portlandmaine.gov](http://www.portlandmaine.gov), stop by the Building Inspections office, room 315 City Hall or call 874-8703.

I hereby certify that I am the Owner of record of the named property, or that the owner of record authorizes the proposed work and that I have been authorized by the owner to make this application as his/her authorized agent. I agree to conform to all applicable laws of this jurisdiction. In addition, if a permit for work described in this application is issued, I certify that the Code Official's authorized representative shall have the authority to enter all areas covered by this permit at any reasonable hour to enforce the provisions of the codes applicable to this permit.

Signature of applicant

*Wayne Hinckley*

Date: 12-7-06

This is not a permit; you may not commence ANY work until the permit is issued.

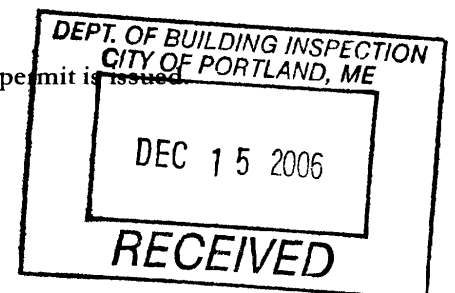

Permit # 06-1800

Applicant: Home Sweet Home Apartments LLC  
(Wayne Hinckley)

Date: 12/20/06

Address: (37-43) Brainiac St. (Lot 1)

C-B-L: 336-F-25\*

NEW CBL 336-F-27

CHECK-LIST AGAINST ZONING ORDINANCE

Date - new

Zone Location - R2

Interior or corner lot -

Proposed Use/Work - build new 2 story single family house 28x32 w/ a <sup>one</sup> car garage.

Sevage Disposal - city

Lot Street Frontage - 50' min - 105' given

Front Yard - 25' min. ~~25'~~ - 38.5' scaled

Rear Yard - 25' min - 29' scaled

Side Yard - 1 1/2 stories - 12' min. 20' scaled on right  
2 stories - 14' min. 56' scaled on left.

Projections -

Width of Lot - 80' min - 100' scaled

Height - 35' max. - 21.25' scaled.

Lot Area - 10,000 sq ft min. - 10,500

Lot Coverage Impervious Surface - 20% = 2100 sq ft O/C 28x32 = 896

Area per Family - 10,000 sq ft

Off-street Parking - 2 spaces required - 1 car garage & 1 space shown.

Loading Bays - N/A

Site Plan - minor/minor 2006-0240

Shoreland Zoning/Stream Protection - N/A

Flood Plains - parcel 1 - zone C

\* street needs to be built

**CITY OF PORTLAND, MAINE  
DEVELOPMENT REVIEW APPLICATION  
PLANNING DEPARTMENT PROCESSING FORM**

**Zoning Copy**

**2006-0240**

Application I. D. Number

**12/19/2006**

Application Date

**Braintree St**

Project Name/Description

**Home Sweet Home LLC**

Applicant

**49 Northern Oaks Dr., Raymond, ME 04071**

Applicant's Mailing Address

**Wayne Hinckley**

Consultant/Agent

**Applicant Ph: (207) 831-8505 Agent Fax:**

Applicant or Agent Daytime Telephone, Fax

**31 - 41 , Portland, Maine**

Address of Proposed Site

Assessor's Reference: Chart-Block-Lot

Proposed Development (check all that apply):  New Building  Building Addition  Change Of Use  Residential  Office  Retail  
 Manufacturing  Warehouse/Distribution  Parking Lot  Apt 0  Condo 0  Other (specify) \_\_\_\_\_

Proposed Building square Feet or # of Units

Acreage of Site

Zoning

**Check Review Required:**

- |   |   |  |
|---|---|--|
| <input type="checkbox"/> Site Plan (major/minor)          | <input type="checkbox"/> Zoning Conditional - PB  | <input type="checkbox"/> Subdivision # of lots _____ |
| <input type="checkbox"/> Amendment to Plan - Board Review | <input type="checkbox"/> Zoning Conditional - ZBA | <input type="checkbox"/> Shoreland                   |
| <input type="checkbox"/> Amendment to Plan - Staff Review | <input type="checkbox"/> Zoning Variance          | <input type="checkbox"/> Flood Hazard                |
| <input type="checkbox"/> After the Fact - Major           | <input type="checkbox"/> Stormwater               | <input type="checkbox"/> Traffic Movement            |
| <input type="checkbox"/> After the Fact - Minor           | <input type="checkbox"/> PAD Review               | <input type="checkbox"/> 14-403 Streets Review       |
|   |   | <input type="checkbox"/> DEP Local Certification     |
|   |   | <input type="checkbox"/> Site Location               |
|   |   | <input type="checkbox"/> Other _____                 |

Fees Paid: Site Plan \$50.00 Subdivision \_\_\_\_\_ Engineer Review \$250.00 Date 12/19/2006

**Zoning Approval Status:**

Reviewer \_\_\_\_\_

- Approved**  **Approved w/Conditions**  **Denied**  
See Attached

Approval Date \_\_\_\_\_ Approval Expiration \_\_\_\_\_ Extension to \_\_\_\_\_  Additional Sheets Attached

Condition Compliance \_\_\_\_\_  
signature \_\_\_\_\_ date \_\_\_\_\_

**Performance Guarantee**  **Required\***  **Not Required**

\* No building permit may be issued until a performance guarantee has been submitted as indicated below

- |   |                |  |                 |
|---|----------------|--|-----------------|
| <input type="checkbox"/> Performance Guarantee Accepted     | _____          | _____  | _____           |
|   | date           | amount   | expiration date |
| <input type="checkbox"/> Inspection Fee Paid                | _____          | _____  |                 |
|   | date           | amount   |                 |
| <input type="checkbox"/> Building Permit Issue              | _____          |  |                 |
|   | date           |  |                 |
| <input type="checkbox"/> Performance Guarantee Reduced      | _____          | _____  | _____           |
|   | date           | remaining balance                                  | signature       |
| <input type="checkbox"/> Temporary Certificate of Occupancy | _____          | <input type="checkbox"/> Conditions (See Attached) | _____           |
|   | date           |  | expiration date |
| <input type="checkbox"/> Final Inspection                   | _____          | _____  |                 |
|   | date           | signature  |                 |
| <input type="checkbox"/> Certificate Of Occupancy           | _____          |  |                 |
|   | date           |  |                 |
| <input type="checkbox"/> Performance Guarantee Released     | _____          | _____  |                 |
|   | date           | signature  |                 |
| <input type="checkbox"/> Defect Guarantee Submitted         | _____          | _____  | _____           |
|   | submitted date | amount   | expiration date |
| <input type="checkbox"/> Defect Guarantee Released          | _____          | _____  |                 |
|   | date           | signature  |                 |



**KNOW ALL MEN BY THESE PRESENTS,**

**THAT**, I, Daniel C. McDonald, II, of Naples, Florida in consideration of One Dollar (\$1.00) and other good and valuable considerations paid by Wayne E. Hinckley, whose mailing address is 49 Northern Oaks Drive, Raymond, Maine 04071, the receipt whereof I do hereby acknowledge, do hereby give, grant, bargain, sell and convey unto the said , Wayne E. Hinckley, his heirs and assigns forever,

Certain lots or parcels of land with the improvements thereon, situated in the City of Portland, Maine, which consists of certain of the lots numbered 259-265 as shown on a certain "Plan of Woodfords Gardens" owned by J.W. Wilbur, Co., dated November 16, 1916 and recorded in Cumberland County Registry of Deeds in Plan Book 13 at Page 75. Said lots are commonly known or referred to as 31-41 Braintree Street and 27-29 Braintree Street.

These lots are a portion of the lots conveyed to said Grantor, by deed of distribution dated March 21, 21, 1984 and recorded in the Cumberland County Registry of Deeds in Book 6409, page 125.

**TO HAVE AND TO HOLD** the aforegranted and bargained premises, with all the privileges and appurtenances thereof, to the said Grantee, his heirs and assigns, to their own use and behoof forever.

**AND** I do covenant with the said Grantee, his heirs and assigns, that I am lawfully seized in fee of the premises, that they are free of all encumbrances; that we/I have good right to sell and convey the same to the said Grantee(s) to hold as aforesaid, and that we/I and my heirs shall and will **WARRANT AND DEFEND** the same to the said Grantee(s), their heirs and assigns forever, against the lawful claims and demands of all persons.

**IN WITNESS WHEREOF**, I Daniel C. McDonald, II the said Grantor, have hereunto set my hand and seal this 30 day of July, 2004.

**SIGNED, SEALED AND DELIVERED**  
in the presence of,

Mary M. Lyles

Daniel C. McDonald II  
Daniel C. McDonald

**MAINE REAL ESTATE TAX PAID**

STATE OF FLORIDA,  
COUNTY OF COLLIER, ss.

July 30, 2004.

Personally appeared the above-named Daniel C. McDonald, II and acknowledged the foregoing instrument to be his free act and deed.

Before me,

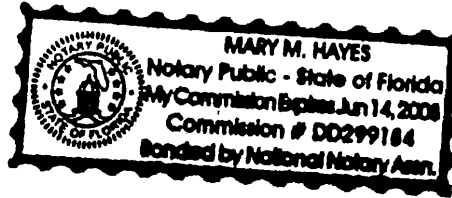

Mary M Hayes  
Notary Public

Print: MARY M HAYES

F:\CLIENTS\hinckley wayne\Deed-MacDonald to Hinckley.doc

Received  
Recorded Register of Deeds  
Aug 27, 2004 02:52:55P  
Cumberland County  
John B O'Brien

Return to: Perkins Olson  
PO Box 449  
Portland, ME  
04112

QUIT-CLAIM DEED  
With Covenant

KNOW ALL MEN BY THESE PRESENTS, THAT I, WAYNE E. HINCKLEY of Raymond, County of Cumberland, and State of Maine, in consideration of One Dollar and other valuable consideration, paid by HOME SWEET HOME APARTMENTS, LLC , whose mailing address is: 49 Northern Oaks Drive, Raymond, Maine 04071 the receipt whereof I do hereby acknowledge, do hereby remise, release, bargain, sell and convey, and forever quitclaim unto the said Home Sweet Home Apartments, LLC, its heirs and assigns forever, a certain lot or parcel of land, with any buildings thereon, situated in the Town of Portland, County of Cumberland, and State of Maine, being further described as follows:

Certain lots or parcels of land with the improvements thereon, situated in the city of Portland, Maine, which consists of certain of the lots numbered 259-265 as shown on a certain "Plan of Woodfords Gardens" owned by J.W. Wilbur, Co., dated November 16, 1916 and recorded in Cumberland County Registry of Deeds in Plan Book 13 at Page 75. Said lots are commonly known or referred to as 31-41 Braintree Street and 27-29 Braintree Street.

The premises are conveyed subject to any easements and restrictions of record, and this deed includes all rights, easements, privileges and appurtenances belonging to the premises hereinabove described.

Being the same premises conveyed to Wayne E. Hinckley by deed from Daniel C. McDonald, II dated July 30, 2004, and recorded in the Cumberland County Registry of Deeds in Book 21717, Page 217.

TO HAVE AND TO HOLD the same, together with all the privileges and appurtenances thereunto belonging, to the said Home Sweet Home Apartments, LLC, its successors and assigns, to their own use and behoof forever.

AND I do COVENANT with the Grantee, its successors and assigns, that I shall and will WARRANT AND DEFEND the premises to the said Grantee, its successors and assigns forever, against the lawful claims and demands of all persons claiming by, through, or under me.

IN WITNESS WHEREOF, I the said Wayne E. Hinckley, as Grantor, have hereunto set my hand and seal this 14 day of the month of February, 2005.

SIGNED, SEALED AND DELIVERED

in presence of,

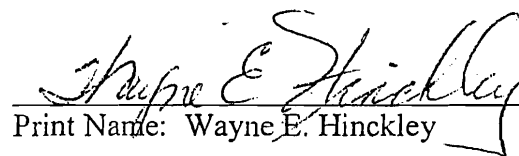
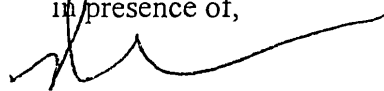

Print Name: Wayne E. Hinckley

STATE OF MAINE  
COUNTY OF CUMBERLAND, ss.

February 14<sup>th</sup>, 2005

Then personally appeared the above-named Wayne E. Hinckley and acknowledged the foregoing instrument to be his free act and deed.

Before me,



Notary Public *ATTM-110*

Print: RICHARD F. OLSON

\\hinckley wayne\Quit claim deed with cov-ind.doc

**MAINE REVENUE SERVICES  
REAL ESTATE TRANSFER  
TAX DECLARATION**

TITLE 36, M.R.S.A. SECTIONS 4641 - 4641N



PLEASE TYPE OR USE A BALL POINT PEN. FILE BOTH COPIES WITH THE COUNTY REGISTRY OF DEEDS. DO NOT USE STAPLES OR TAPE AND DO NOT DETACH!

▶ 1. MUNICIPALITY OR TOWNSHIP Portland	▶ COUNTY Cumberland
---	------------------------

▶ BOOK/PAGE (REGISTRY USE ONLY)

<b>GRANTEE (BUYER)</b>	
▶ 2. IDENTITY: NAME(S) - LAST, FIRST, MIDDLE OR CORPORATE NAME(S) Home Sweet Home Apartment,s LLC	▶ ENTER SSN OR FED ID HERE 35-2205693

3. NUMBER AND STREET 49 Northern Oaks Drive	CITY OR TOWN Raymond	STATE AND ZIP CODE ME 04071
--	-------------------------	--------------------------------

<b>GRANTOR (SELLER)</b>	
▶ 4. IDENTITY: NAME(S) - LAST, FIRST, INITIAL OR CORPORATE NAME(S) Hinckley, Wayne E.	▶ ENTER SSN OR FED ID HERE 014-52-7663

5. NUMBER AND STREET 49 Northern Oaks Drive	CITY OR TOWN Raymond	STATE AND ZIP CODE ME 04071
--	-------------------------	--------------------------------

<b>PROPERTY</b>	▶ 6. TAX MAP & LOT NUMBER Map 336, Block F, Lots 25-29 and	<b>WARNING TO BUYER!</b> If the property is classified as Farmland, Open Space or Tree Growth, a substantial financial penalty could be triggered by Development, subdivision, partition or change in use. <input type="checkbox"/> Classified <input checked="" type="checkbox"/> Not Classified
	▶ 7. DATE OF TRANSFER MO DAY YEAR 2 14 05	

<b>CONSIDERATION</b>	8. Tax will be collected at the registry when the deed is recorded. The tax rate is \$2.20 per \$500, or fractional part thereof, of consideration or value. The tax is equally divided between the buyer and the seller. See reverse for instructions. FAIR MARKET VALUE \$ 12,000.00	▶ CONSIDERATION \$ 0.00 (ACTUAL PRICE PAID OR REQUIRED TO BE PAID)
----------------------	---	---

<b>EXEMPTION</b>	9. If one or more parties are exempt from the real estate transfer tax, please explain the basis for exemption pursuant to Title 36, M.R.S.A., Section 4641-C. Complete only if the transfer is claimed to be fully or partially exempt. <input type="checkbox"/> GRANTEE Reason: Transfer is exempt pursuant to 35 M.R.S.A. Section 4641-C Section 16 and 19 as a deed <input type="checkbox"/> GRANTOR Reason: to an LLC by its sole member
------------------	---

<b>SPECIAL CIRCUMSTANCES</b>	10. Were there any special circumstances in the transfer which suggests that the price of the property was either more or less than its fair market value? (IF YES, PLEASE EXPLAIN) ▶ NO <input type="checkbox"/> YES <input checked="" type="checkbox"/> member to LLC
------------------------------	--

<b>INCOME TAX WITHHELD</b>	11. <input type="checkbox"/> Buyer(s) certify that they have withheld Maine income tax from the purchase price as required by § 5250-A and will remit to Maine Revenue Services within 30 days after date of transfer. <input checked="" type="checkbox"/> Buyer(s) not required to withhold Maine income tax because: <input checked="" type="checkbox"/> Seller has qualified as a Maine resident <input type="checkbox"/> A waiver has been received from the State Tax Assessor <input checked="" type="checkbox"/> Consideration for the property is less than \$50,000 <input type="checkbox"/> Foreclosure sale: exempt per 36 MRSA §5250-A, sub 3-A
----------------------------	--

<b>OATH</b>	12. Aware of penalties as set forth by Title 36, Section 4641-K, we hereby swear or affirm that we have each examined this return and to the best of our knowledge and belief, it is true, correct, and complete. GRANTEE(S) or AUTHORIZED AGENT DATE GRANTOR(S) or AUTHORIZED AGENT DATE HSH by Wayne E. Hinckley 2/14/05 [Signature] 2/14/05
-------------	--

<b>PREPARER</b>	13. Name, address and phone number of person or firm preparing this form. Richard P. Olson, Esq., Perkins Olson, P.A., 30 Milk St., Portland, ME 04101
-----------------	---

-----  
Official Receipt for Recording in:

Cumberland County Registry Of Deeds  
142 Federal Street  
PORTLAND, MAINE 04101

Issued To:

PERKINS & OLSON  
PO BOX 449

PORTLAND ME 04112-

Recording Fees

Document Description	Number	Vol#	Page	Recording Amount
DEED	10903	22337	93	\$13.00
1-HINCKLEY, WAYNE 2-HOME SWEET HOME APARTMENTS LLC 12:22:34p				
T-TAX				\$ .00
12:22:34p				
				----- \$13.00

Collected Amounts

Payment Type	Check Number	Amount
CHECK	110	\$13.00
		----- \$13.00

Total Received :	\$13.00
Less Total Recordings:	\$13.00
Change Due :	----- \$ .00

Thank You  
JOHN B OBRIEN - Register of Deeds

By - Jayne Jordan

Receipt# Date Time  
0206317 02/18/2005 12:23p

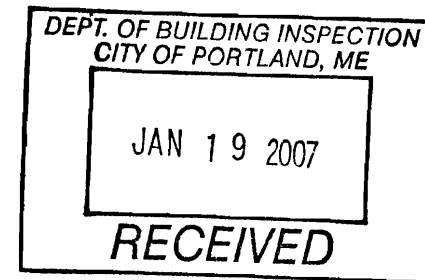

January 17, 2007

Proposed description  
Lot 1  
Braintree Street  
Portland, Maine

A certain lot or parcel of land lying on the easterly side of Braintree Street in the City of Portland, County of Cumberland, State of Maine, bounded and described as follows:

Beginning at a point in the easterly sideline of said Braintree Street at the southwesterly corner of land now or formerly of the Portland Water District as described in a deed recorded in the Cumberland County Registry of Deeds in Book 2156, Page 446. Thence:

- 1) S 89°12'30" E by said land of the Portland Water District a distance of One Hundred and 00/100 (100.00) feet to a point and the northwesterly corner of land now or formerly of the John T. McGovern and Cynthia A. McGovern as described in a deed recorded in said Registry in Book 14837, Page 302.
- 2) S 00°47'30" W by said land of John T. McGovern and Cynthia A. McGovern and land now or formerly of Cynthia A. McGovern as described in a deed recorded in said Registry in Book 14760, Page 306 a distance of One Hundred Five and 00/100 (105.00) feet to a point.
- 3) N 89°12'30" W a distance of One Hundred and 00/100 (100.00) feet to a point in said Braintree Street.
- 4) N 00°47'30" E by said Braintree Street a distance of One Hundred Five and 00/100 (105.00) feet to the point of beginning.

Bearings are referenced to magnetic north 1919.

The above described parcel contains 10,500 square feet. Meaning and intending to describe a portion of the property conveyed to Home Sweet Home Apartments, LLC as described in a deed recorded in the Cumberland County Registry of Deeds in Book 22337, Page 93.

Reference is herein made to a plan entitled "Plan of Boundary Survey" made for Pinkham & Greer by Titcomb Associates dated September 30, 2004.

G/LP/204072/Lot 1.dsc

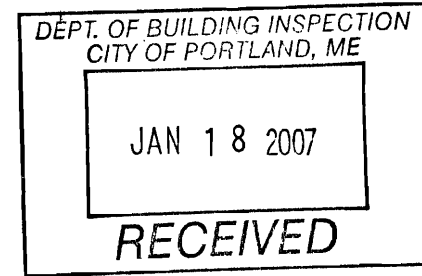

January 17, 2007

Proposed description  
Turnaround Easement  
Braintree Street  
Portland, Maine

A certain easement lying on the easterly side of Braintree Street in the City of Portland, County of Cumberland, State of Maine, bounded and described as follows:

Beginning at a point in the easterly sideline of said Braintree Street at the southwesterly corner of land now or formerly of the Portland Water District as described in a deed recorded in the Cumberland County Registry of Deeds in Book 2156, Page 446. Thence:

- 1) S 89°12'30" E by said land of the Portland Water District a distance of Thirty and 00/100 (30.00) feet to a point.
- 2) S 00°47'30" W a distance of Thirty and 00/100 (30.00) feet to a point.
- 3) N 89°12'30" W a distance of Thirty and 00/100 (30.00) feet to a point in said Braintree Street.
- 4) N 00°47'30" E by said Braintree Street a distance of Thirty and 00/100 (30.00) feet to the point of beginning.

Bearings are referenced to magnetic north 1919.

The above described easement contains 900 square feet. The above described easement lies over a portion of the property conveyed to Home Sweet Home Apartments, LLC as described in a deed recorded in the Cumberland County Registry of Deeds in Book 22337, Page 93.

Reference is herein made to a plan entitled "Plan of Boundary Survey" made for Pinkham & Greer by Titcomb Associates dated September 30, 2004.

G/LP/204072/Turn Ease.dsc



04103



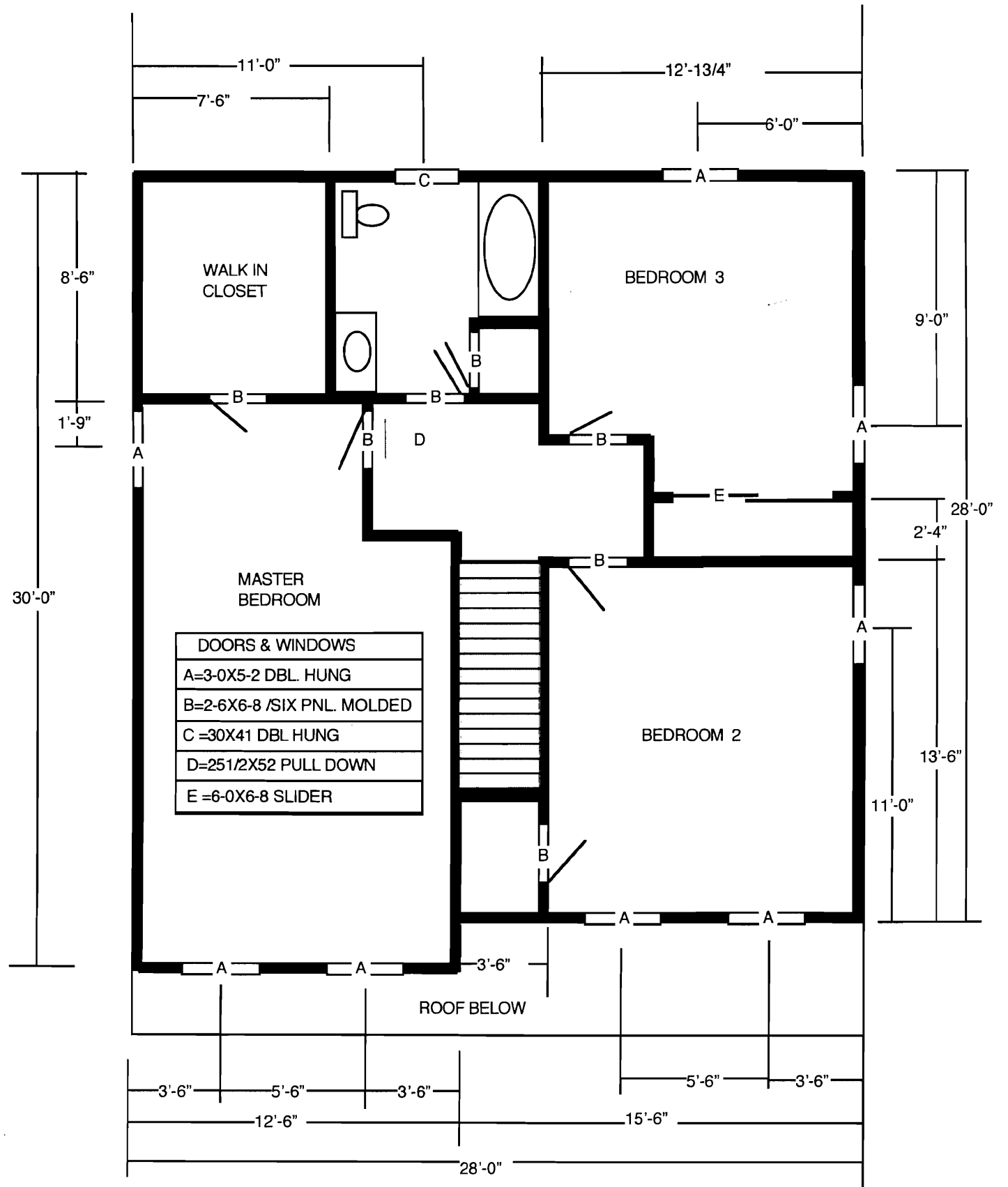

SECOND FLOOR PLAN

CUSTOMER	CONTRACTOR
WAYNE HINCKLEY	
978-387-9074	
DATE : 10/6/05	SCALE 0.5 CM = 1FT

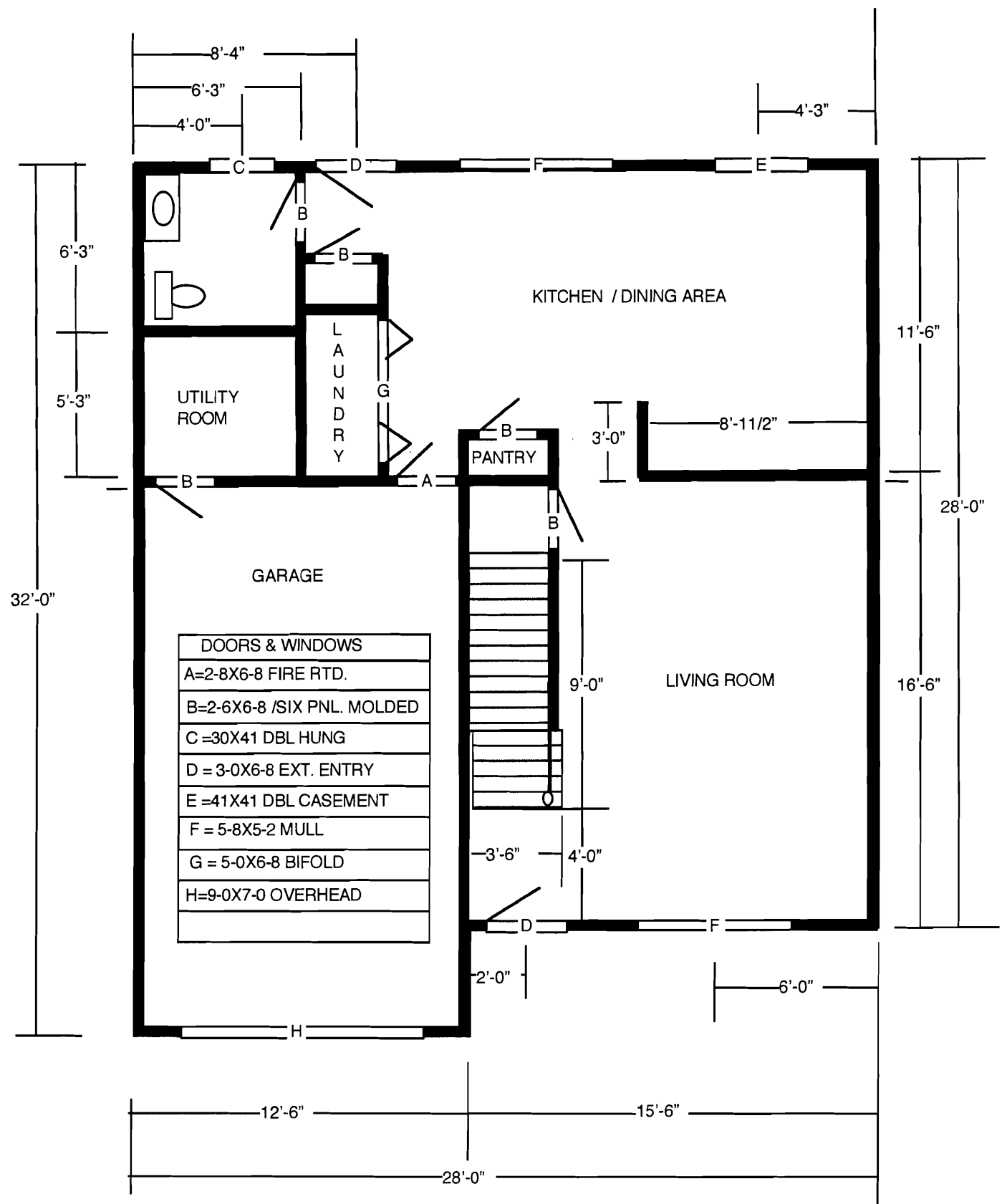

FIRST FLOOR PLAN  
ON CONCRETE SLAB

CUSTOMER	CONTRACTOR
WAYNE HINCKLEY	
978-387-9074	
DATE : 10/6/05	SCALE 0.5 CM = 1FT

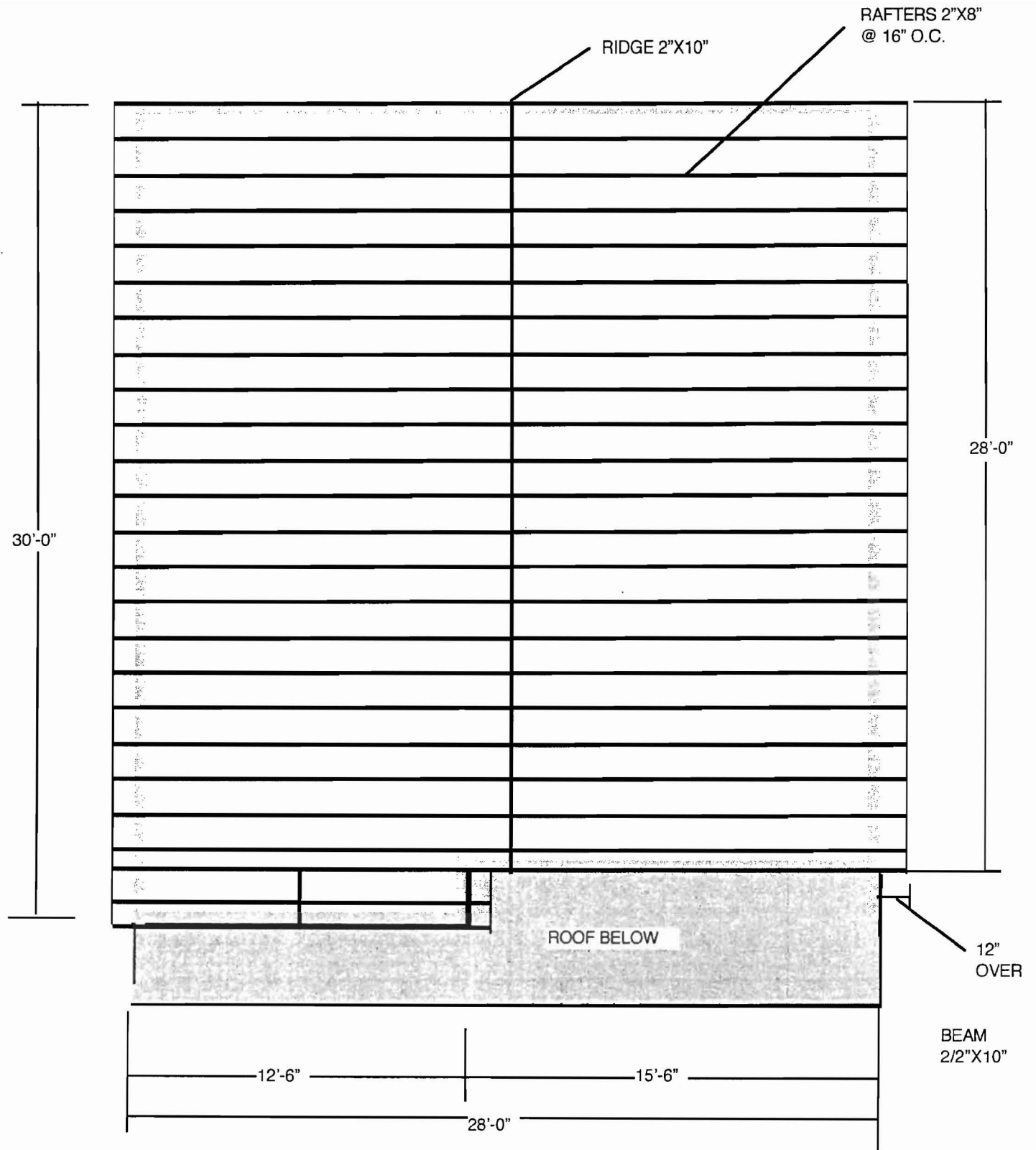

RAFTER PLAN

CUSTOMER	CONTRACTOR
WAYNE HINCKLEY	
978-387-9074	
DATE : 10/6/05	SCALE 0.5 CM = 1FT

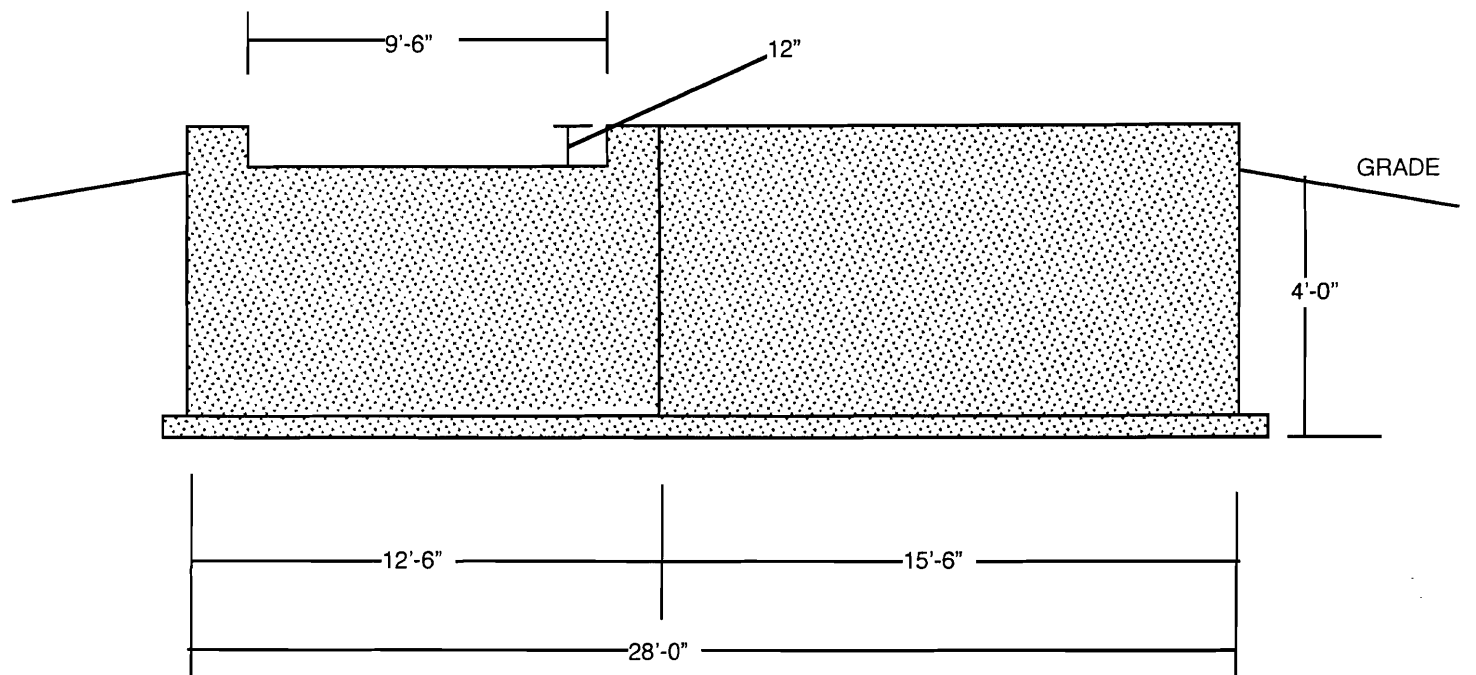

FOUNDATION ELEVATION

CUSTOMER	CONTRACTOR
WAYNE HINCKLEY	
978-387-9074	
DATE : 10/6/05	SCALE 0.5 CM = 1 FT

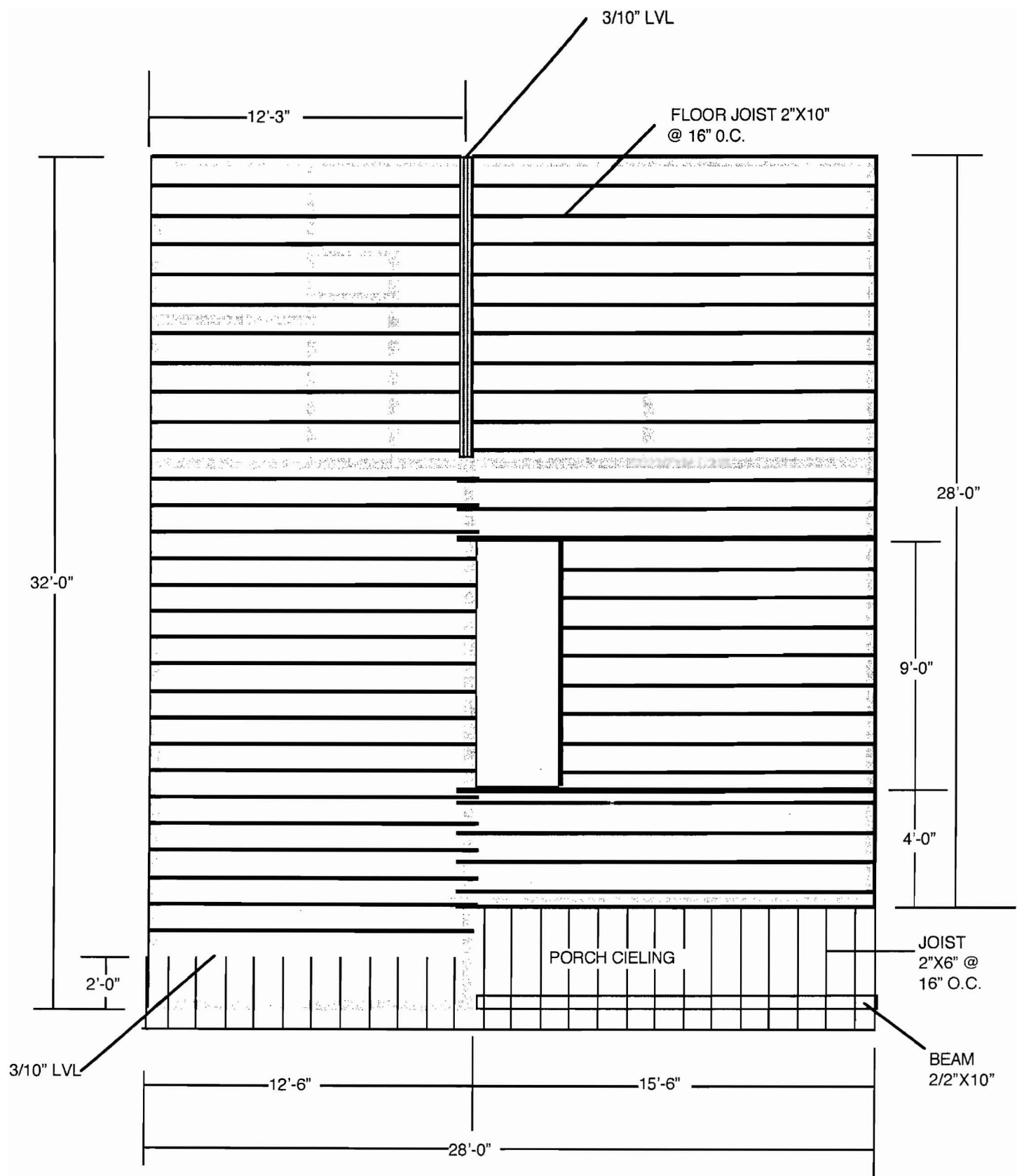

SECOND FLOOR FRAME PLAN

CUSTOMER	CONTRACTOR
WAYNE HINCKLEY	
978-387-9074	
DATE : 10/6/05	SCALE 0.5 CM = 1FT

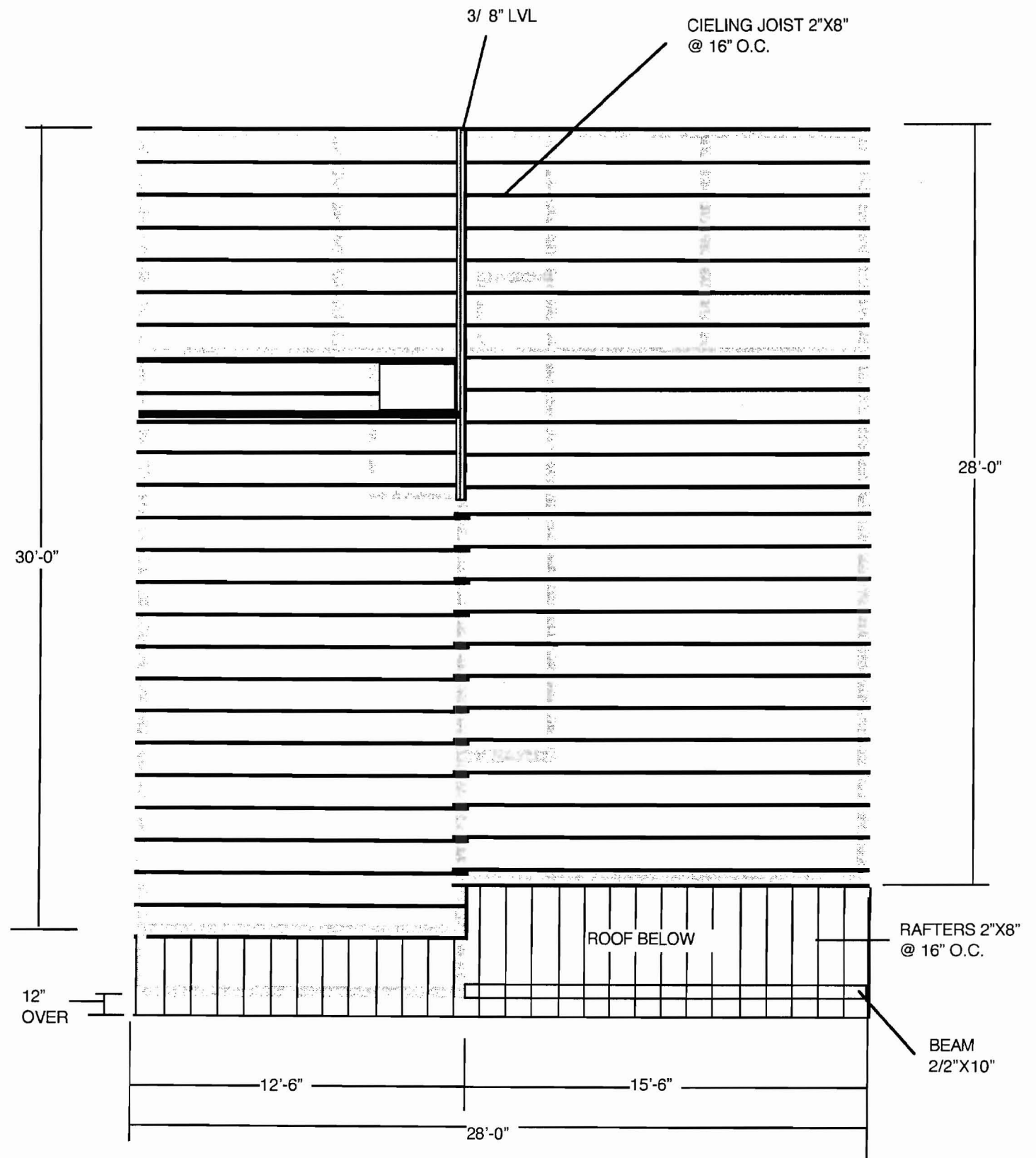

CEILING JOIST PLAN

CUSTOMER	CONTRACTOR
WAYNE HINCKLEY	
978-387-9074	
DATE : 10/6/05	SCALE 0.5 CM = 1FT

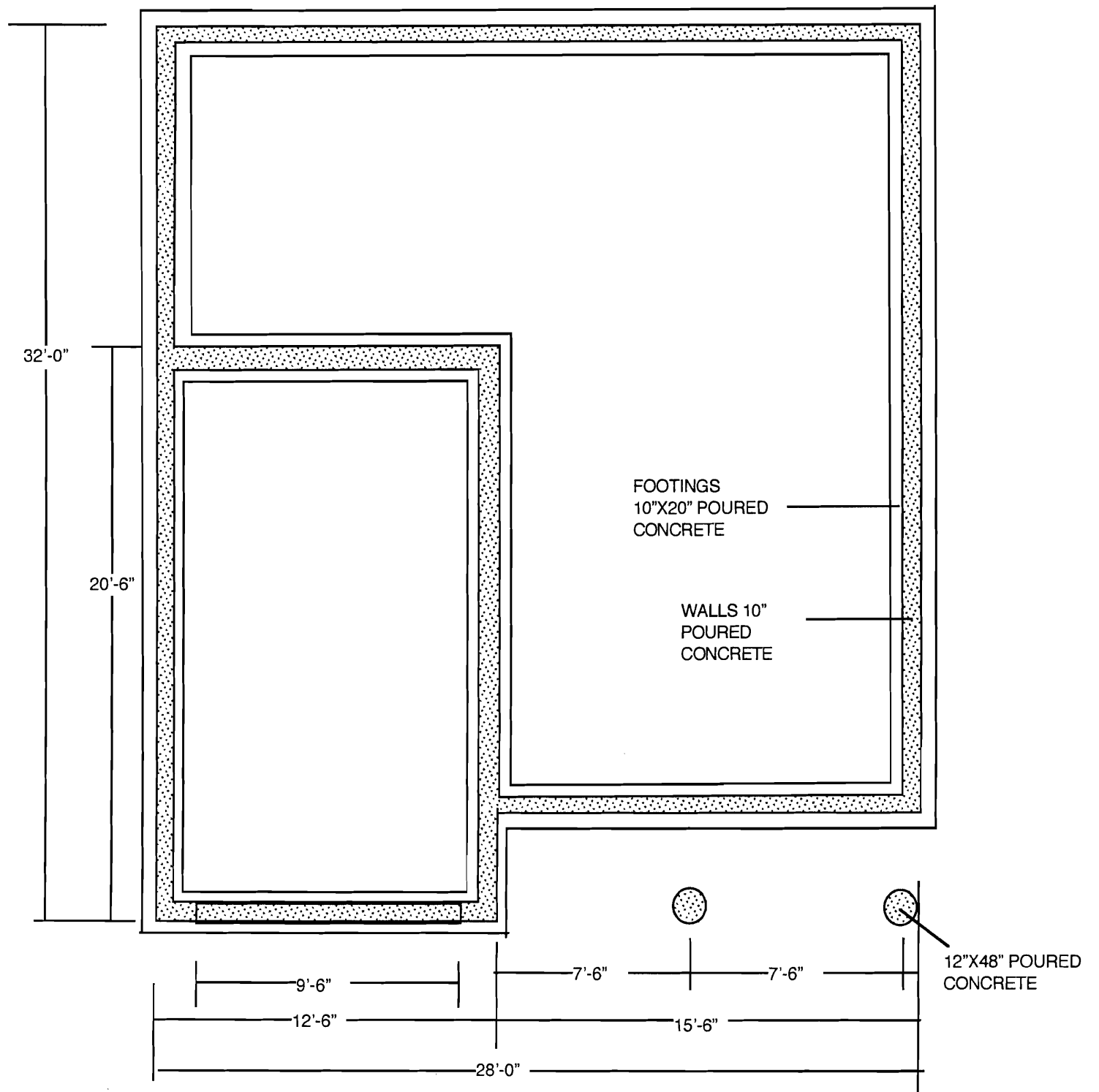

FOUNDATION PLAN

CUSTOMER	CONTRACTOR
WAYNE HINCKLEY	
978-387-9074	
DATE : 10/6/05	SCALE 0.5 CM = 1FT



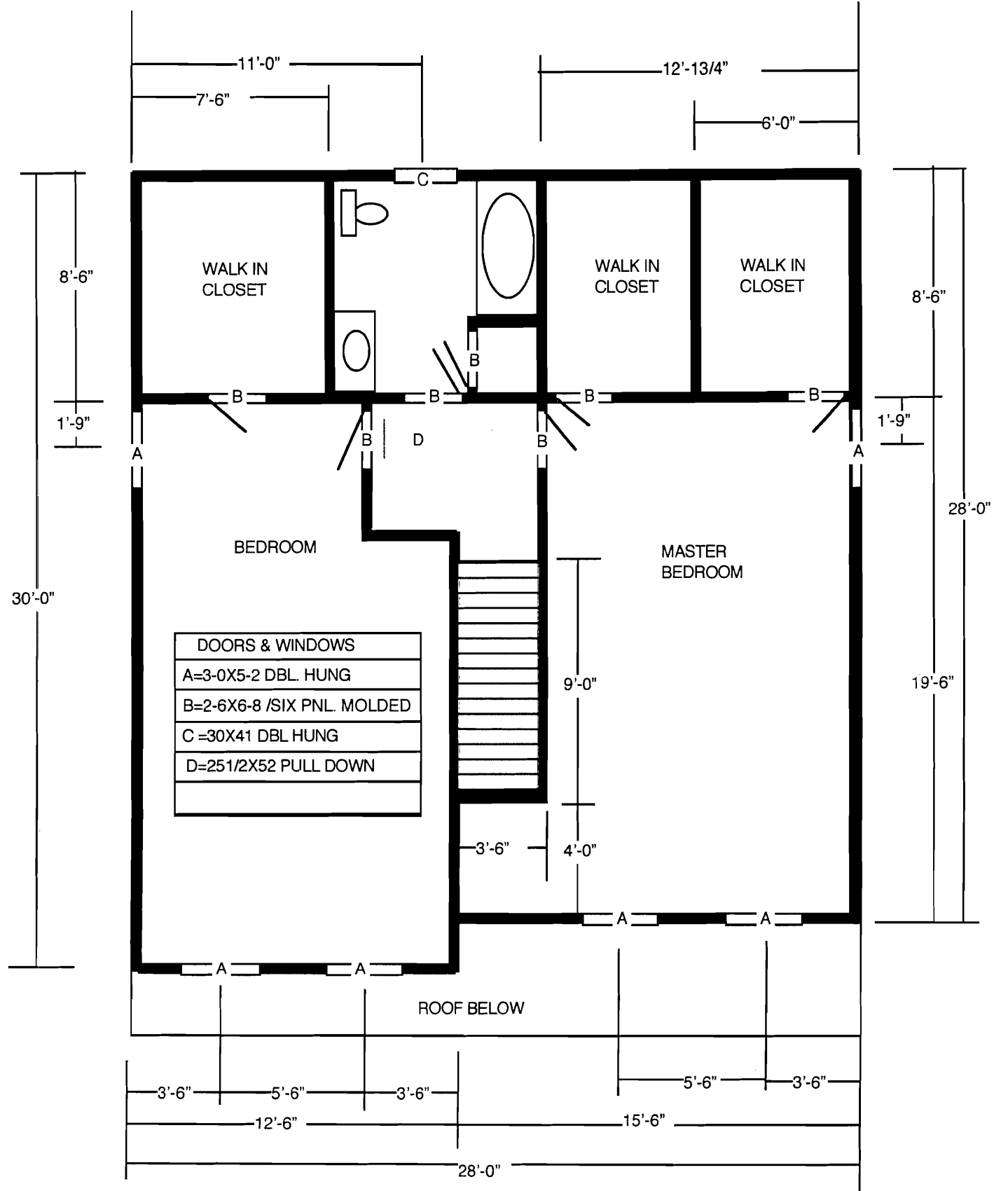

SECOND FLOOR PLAN

CUSTOMER	CONTRACTOR
WAYNE HINCKLEY	
978-387-9074	
DATE : 10/6/05	SCALE 0.5 CM = 1FT

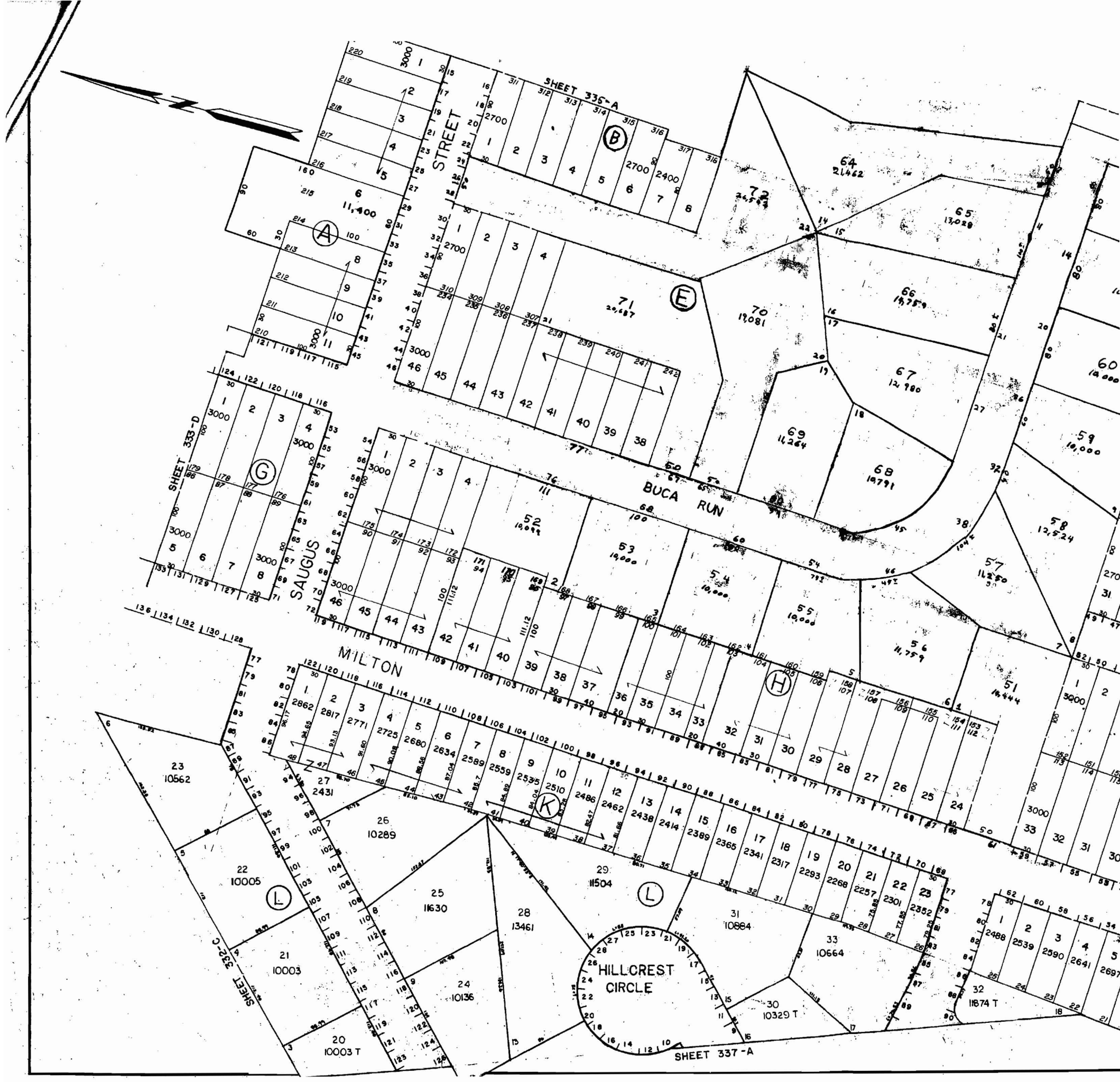



Z VENT AND SHINGLE VENT

PERMIT SHINGLING ROOF OVER 15°F  
ALL 4 SLOPE WIDE RITTHANE &  
WIDE 4 VALLEYS

2" OF PLATE

PER FASADA DETAILS 4x4

WIDE VENT SHUTTERS

ORCH ROOF

HD FLOOR LINE

IRON SHAFT 6" DIAM.

2" CLASSIC FIBERGLASS  
JULIAN TAPERED COLUMN  
1 CAP & BASE (TWO TOTAL)

WOODEN 2x6 CAP & TOP RAIL  
& BOTTOM RAIL & 1/4" x 1/4"  
HINGE

ST. FLOOR LINE

ONE FOUNDATION

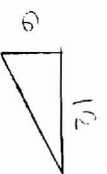

215

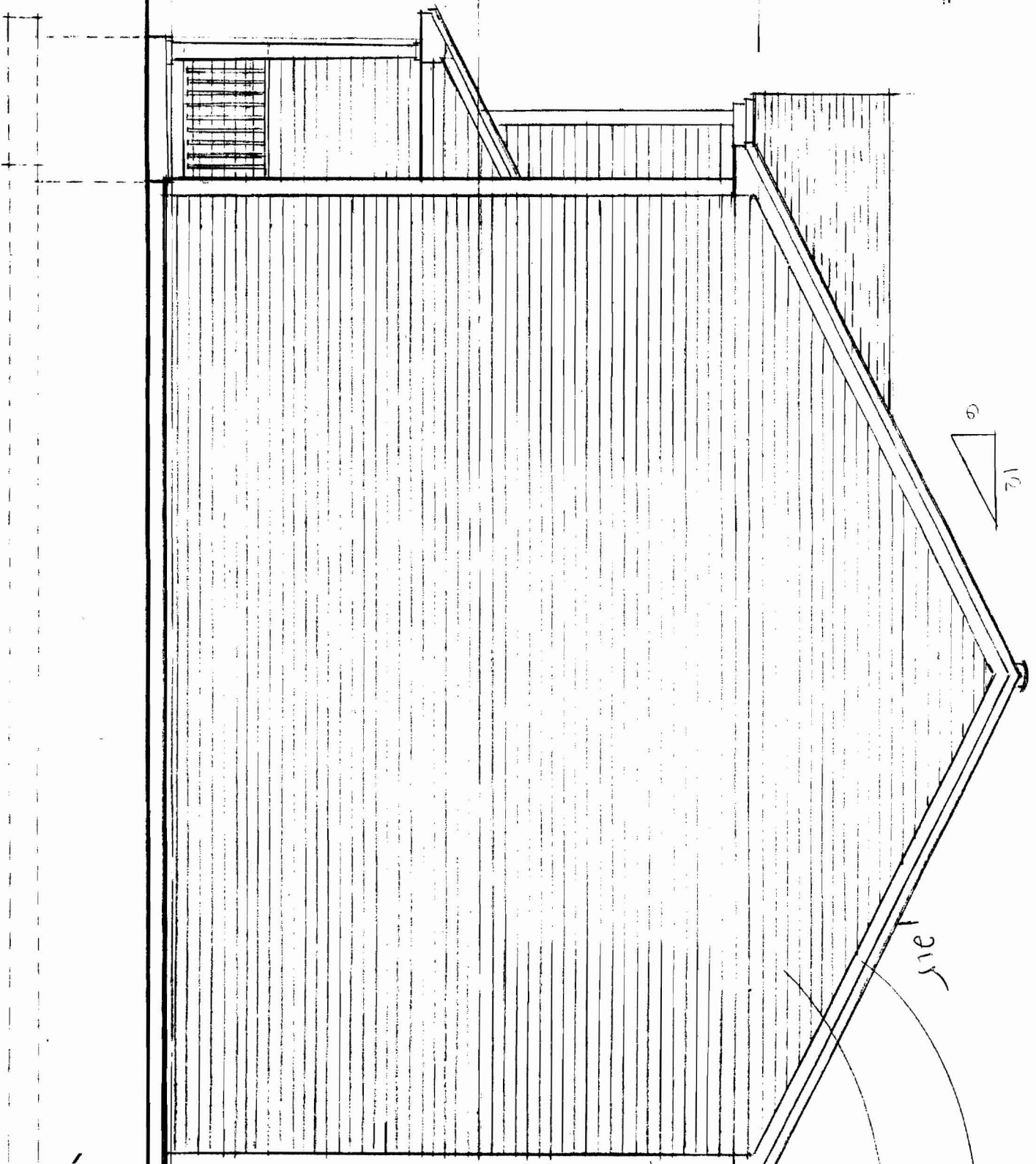

RIGHT END ELEVATION

SCALE: 1/4"=1'-0"

28'-0"

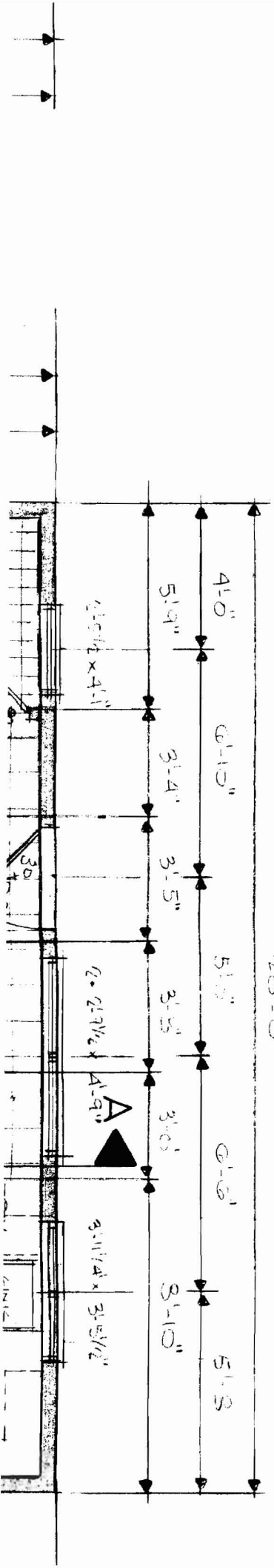

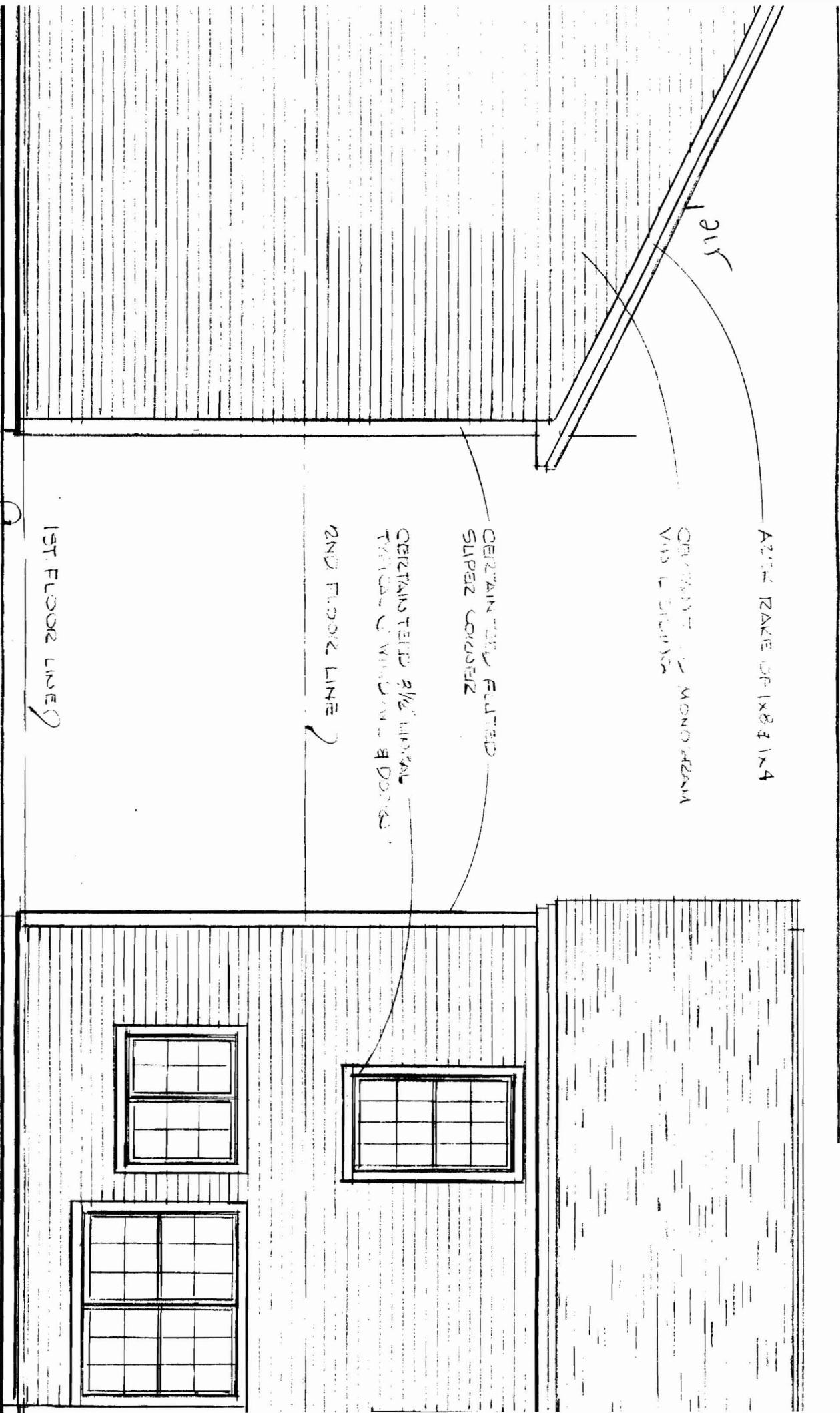

SCALE: 1/4" = 1'-0"

REAR ELEVATION

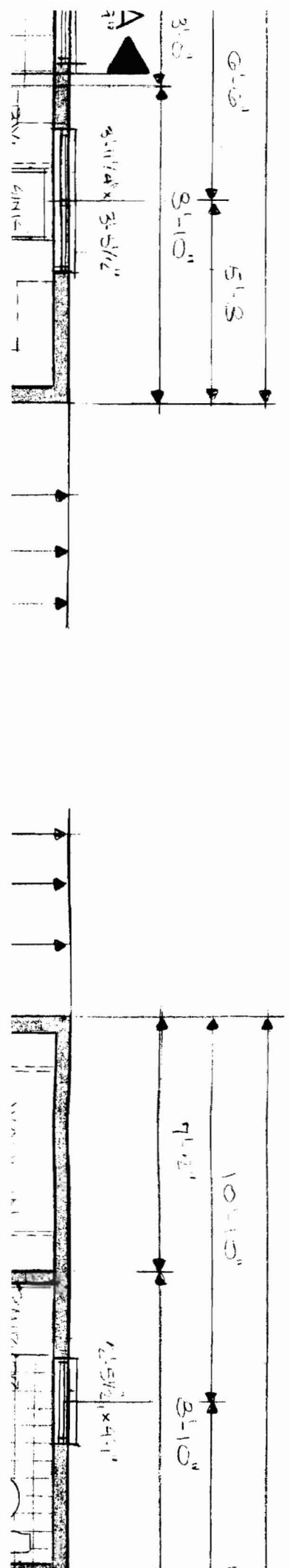

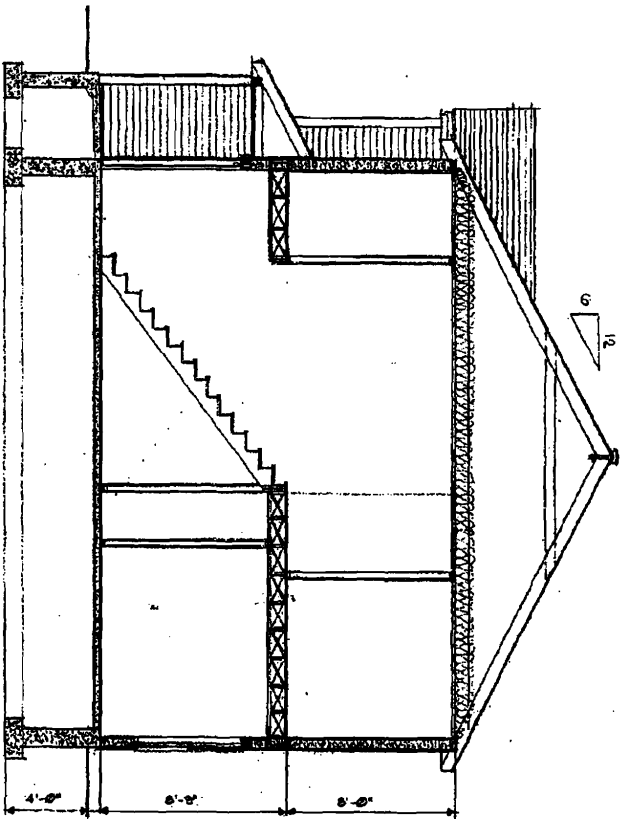

CROSS SECTION AT STAIR SCALE: 1/4" = 1'-0"

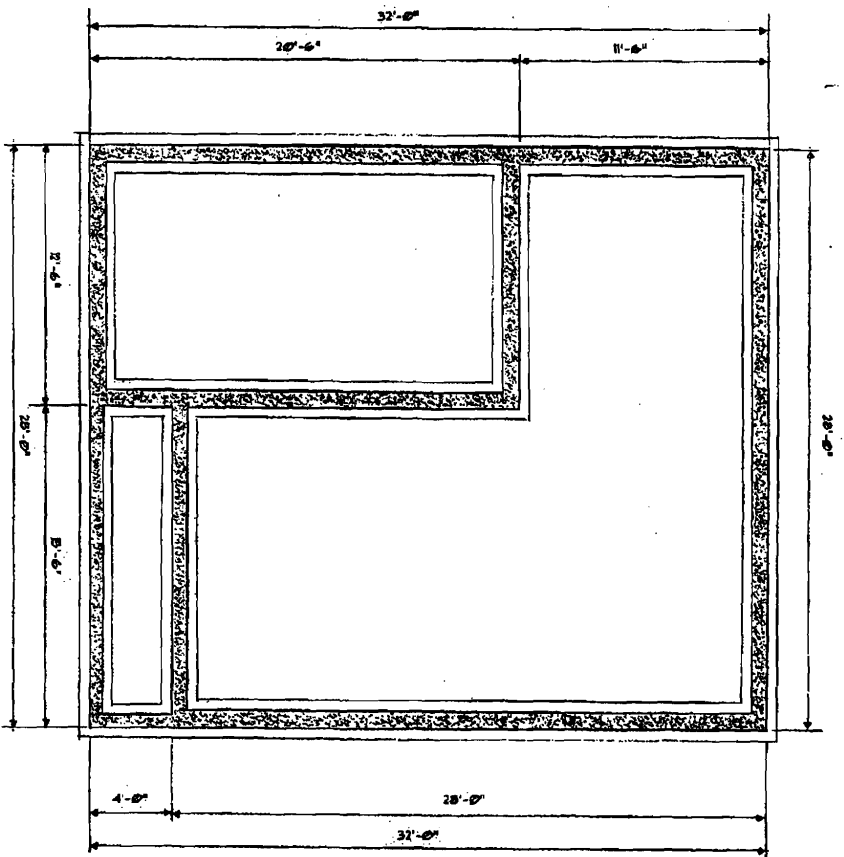

FOUNDATION PLAN SCALE: 1/4" = 1'-0"

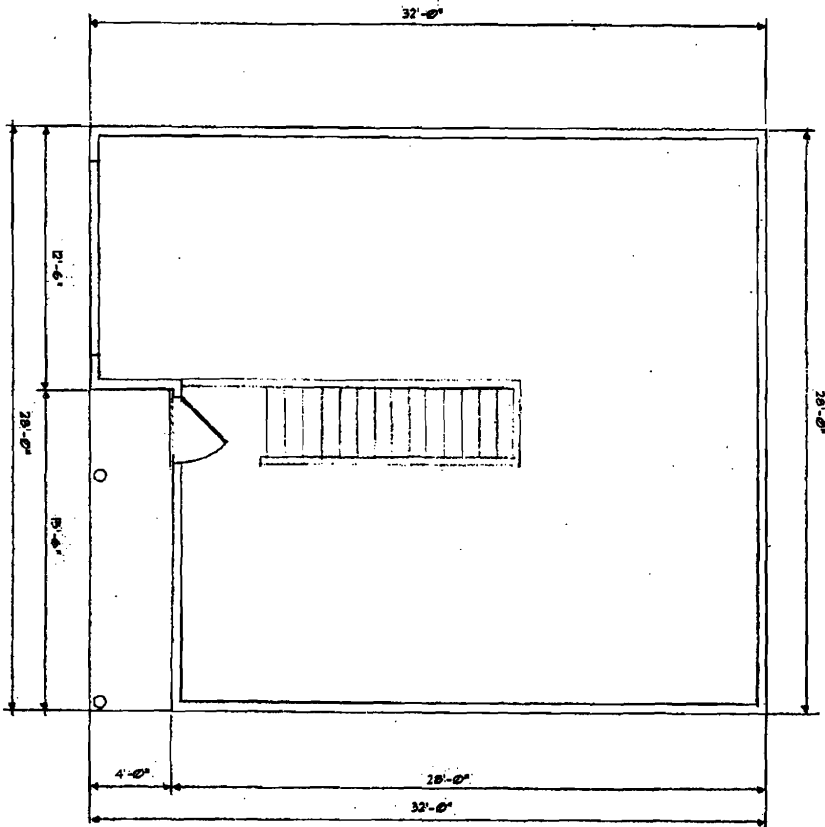

FIRST FLOOR PLAN SCALE: 1/4" = 1'-0"

REVISI  
NO DATE LOCATION

J  
R  
C

E. J. REMPELAKIS AS  
SUITE 201 179 GREAT RD

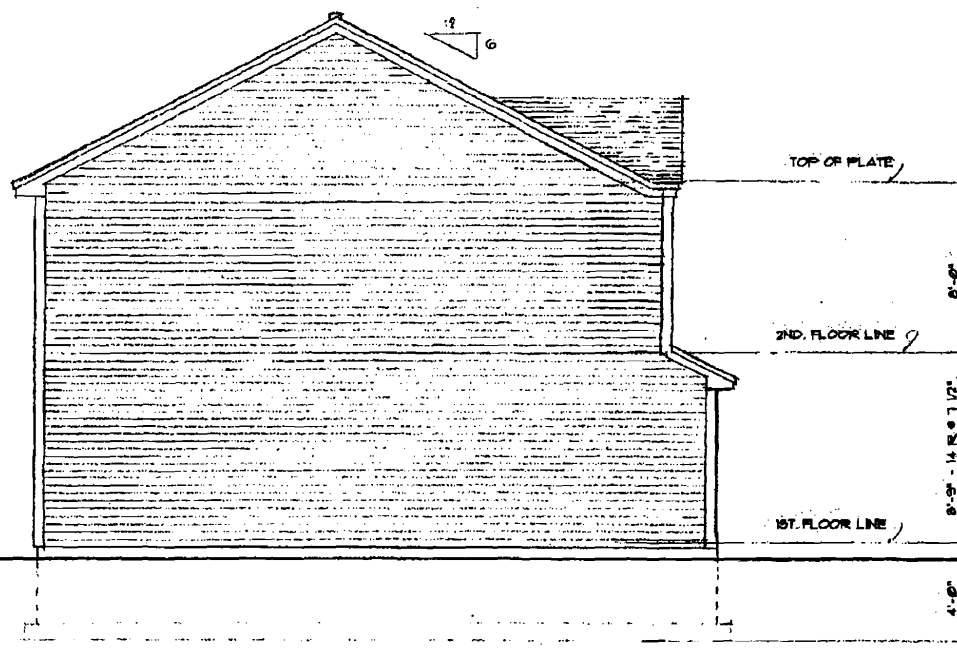

LEFT END ELEVATION

SCALE: 1/4" = 1'-0"

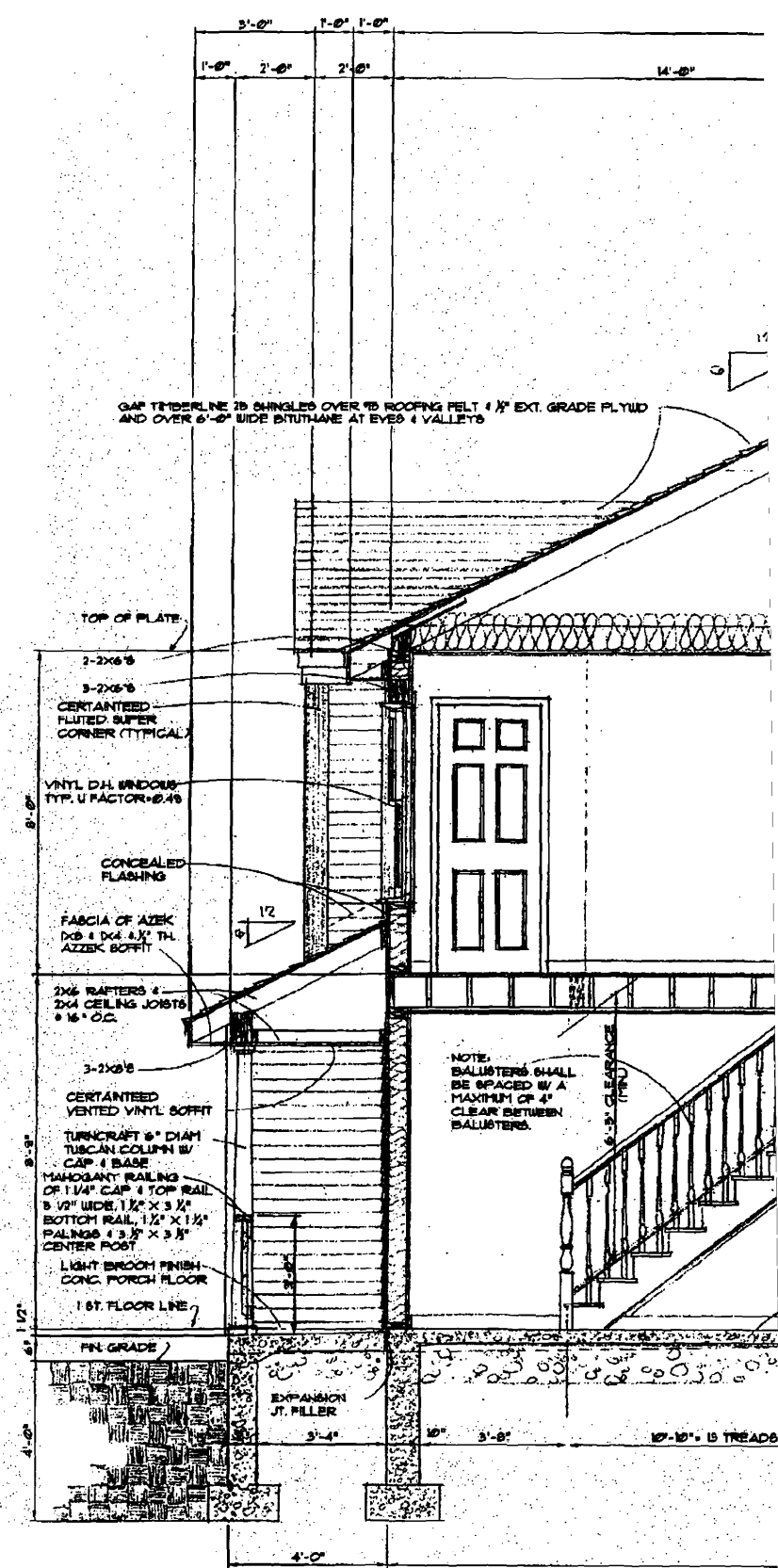

CROSS SECTION A-A

GENERAL NOTES

1. WINDOW SIZES SHOWN ON FLOOR PLANS BASED ON VICON VINYL WINDOWS.
2. INTERIOR DOORS SHALL BE 6 PANEL MOLDED HARDBOARD FACE, HOLLOW CORE.
3. CASINGS & WINDOWS & DOORS SHALL BE BROSCO N'8125 OR N'81B3 (1 1/8" x 1 1/2").
4. DUAL-PANE GLASS (AIR-FILLED) U FACTOR = .45 IN ALL WINDOWS.
5. EXTERIOR DOORS SHALL BE INSULATED STEEL DOORS.

REVISIONS

NO.	DATE	LOCATION
1	JULY 18, 2006	WINDOWS U FACTOR, STAIR BALUSTERS

THE S  
**E. J. REMPELAKIS A**  
 SUITE 201 179 GREAT P

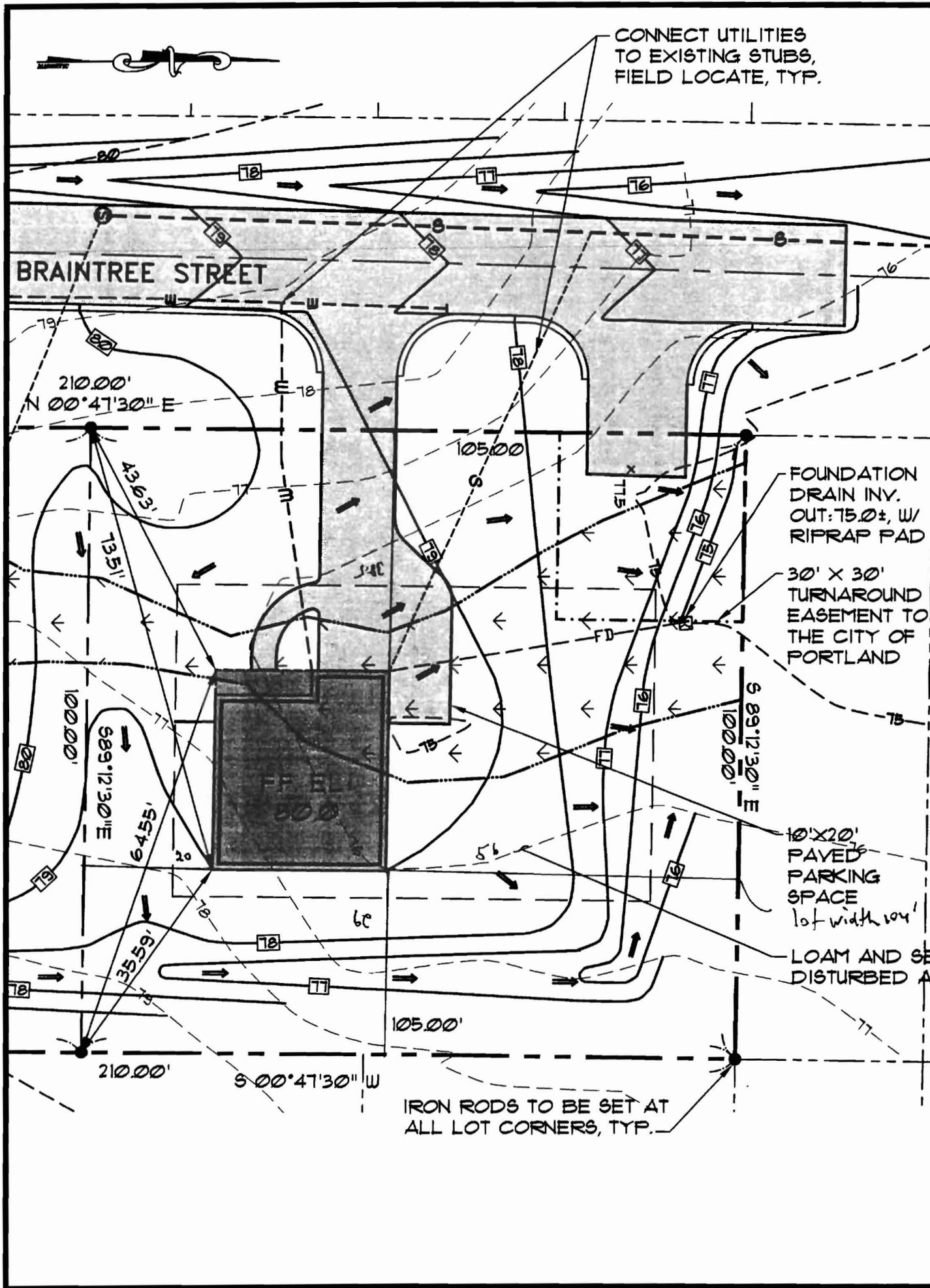

# LEGEND

## EXISTING

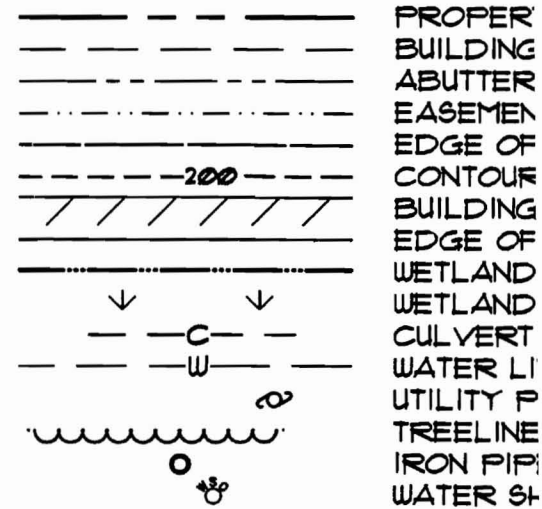

## PROPOSED

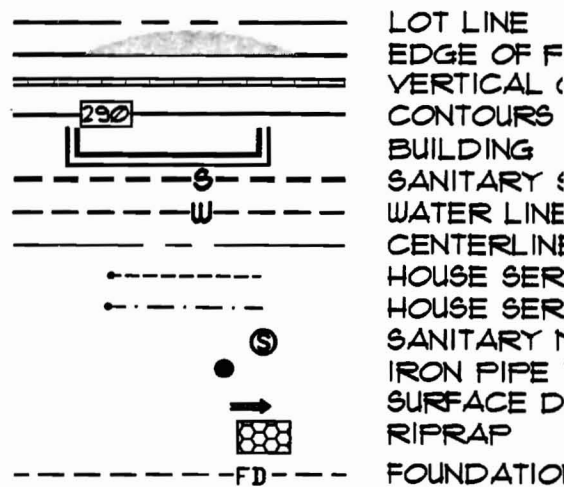

*Used for zoning 19*



*Mark R. Bergeron*  
 12-7-06



DISPLAY THIS CARD ON PRINCIPAL FRONTAGE OF WORK

# CITY OF PORTLAND

## BUILDING INSPECTION PERMIT

Permit Number: 061800

Please Read  
Application And  
Notes, If Any,  
Attached

This is to certify that HOME SWEET HOME APARTMENTS LLC /Wayne Hinckley

has permission to 28' x 32' 2 story house w/ attached garage

AT 0 BRAINTREE ST CBL 336 F025001

provided that the person or persons, firm or corporation accepting this permit shall comply with all of the provisions of the Statutes of Maine and of the Ordinances of the City of Portland regulating the construction, maintenance and use of buildings and structures, and of the application on file in this department.

Apply to Public Works for street line and grade if nature of work requires such information.

Notification of inspection must be given and written permission procured before this building or part thereof is lathed or otherwise closed-in. 24 HOUR NOTICE IS REQUIRED.

A certificate of occupancy must be procured by owner before this building or part thereof is occupied.

**OTHER REQUIRED APPROVALS**

Fire Dept. \_\_\_\_\_

Health Dept. \_\_\_\_\_

Appeal Board \_\_\_\_\_

Other \_\_\_\_\_

Department Name

# WITHDRAW

Director - Building & Inspection Services

**PENALTY FOR REMOVING THIS CARD**



**CITY OF PORTLAND, MAINE**  
Department of Building Inspections

Dec 15 2006

Received from Kevin Sweet Kevin

Location of Work 31-41 Bowdoin St #1

Cost of Construction \$ \_\_\_\_\_ Blk Fee 1,970.00

Permit Fee \$ \_\_\_\_\_ Copy 1,500  
Site 300.00

Building (I1) \_\_\_ Plumbing (I5) \_\_\_ Electrical (I2) \_\_\_ Site Plan (U2) \_\_\_

Other 2000 S/F Total 1,645.00

CBL: 336 F025

Check #: 1197 + 5833 Total Collected \$ 1,145.00

**THIS IS NOT A PERMIT**

No work is to be started until PERMIT CARD is actually posted upon the premises. Acceptance of fee is no guarantee that permit will be granted. PRESERVE THIS RECEIPT. In case permit cannot be granted the amount of the fee will be refunded upon return of the receipt less \$10.00 or 10% whichever is greater.

WHITE - Applicant's Copy  
YELLOW - Office Copy  
PINK - Permit Copy

*Handwritten signature*

SHEET 333-D

SAUGUS

MILTON

BUCA RUN

STREET



SPRINKLER HEADS TO BE OVER 13" H  
 AT 4' SPACING WIDE RITUALS TO BE  
 WOOD & VALUERS

2ND FLOOR PLUMBING

1/2" RADIUS OF CURVATURE

WOOD VERTICAL SPLITTERS

CORNER WOOD

HD FLOOR LINE

IRON SHAFT 6" DIAM.  
 2ND CLASSIC TUBES/VALVES  
 JORDAN TAPERED COLUMN  
 1" CAP & BASE (TWO TOTAL)

PROBANT 2x6 CAP & TOP RAIL  
 1/4" RADIUS (RAMP) 9 1/4" x 1/4"  
 SLINGS

ST. FLOOR LINE

ONC FOUNDATION

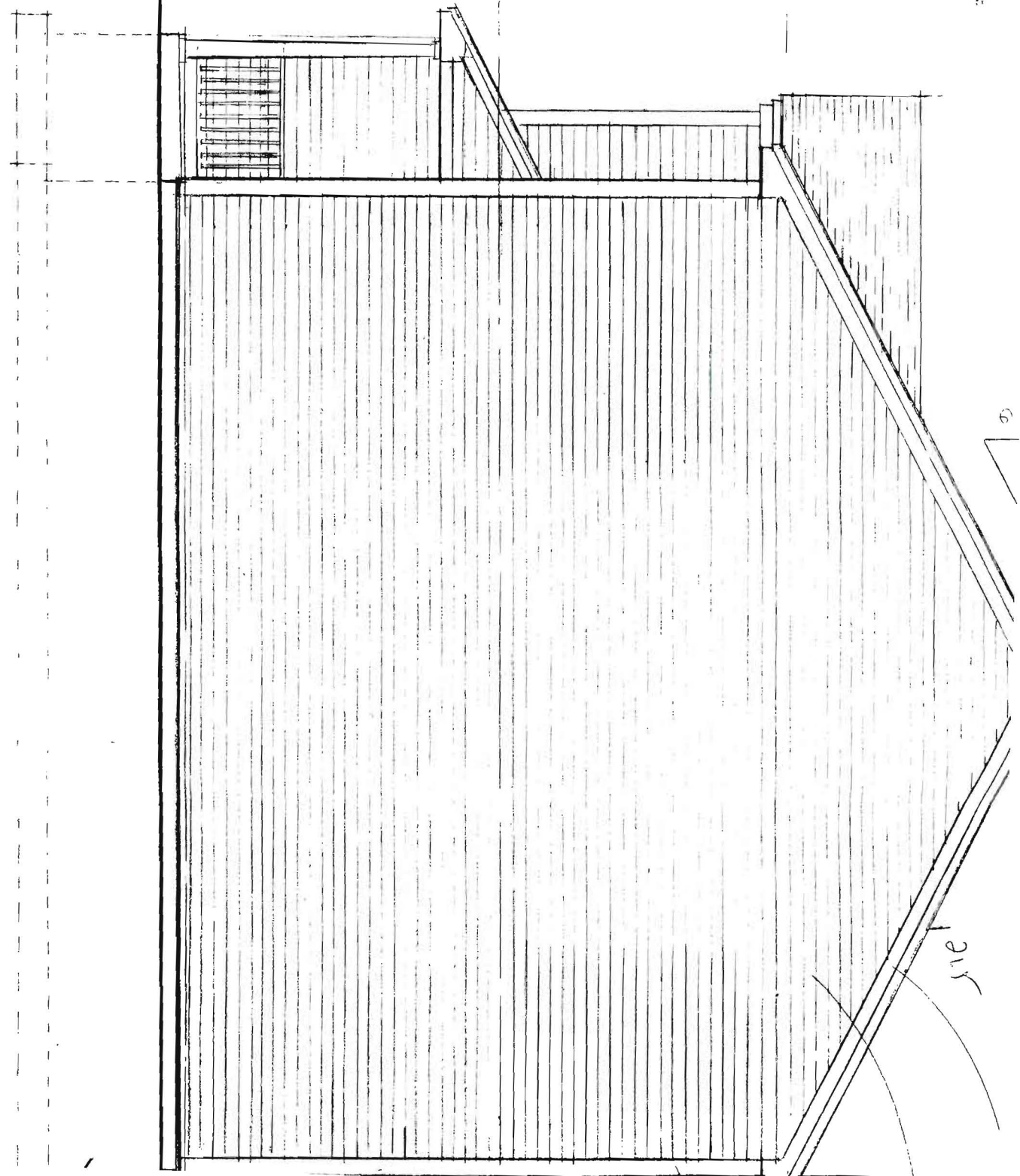

RIGHT END ELEVATION

SCALE: 1/4" = 1'-0"

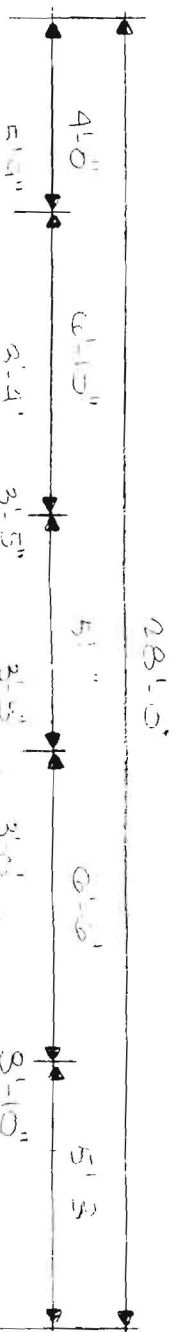

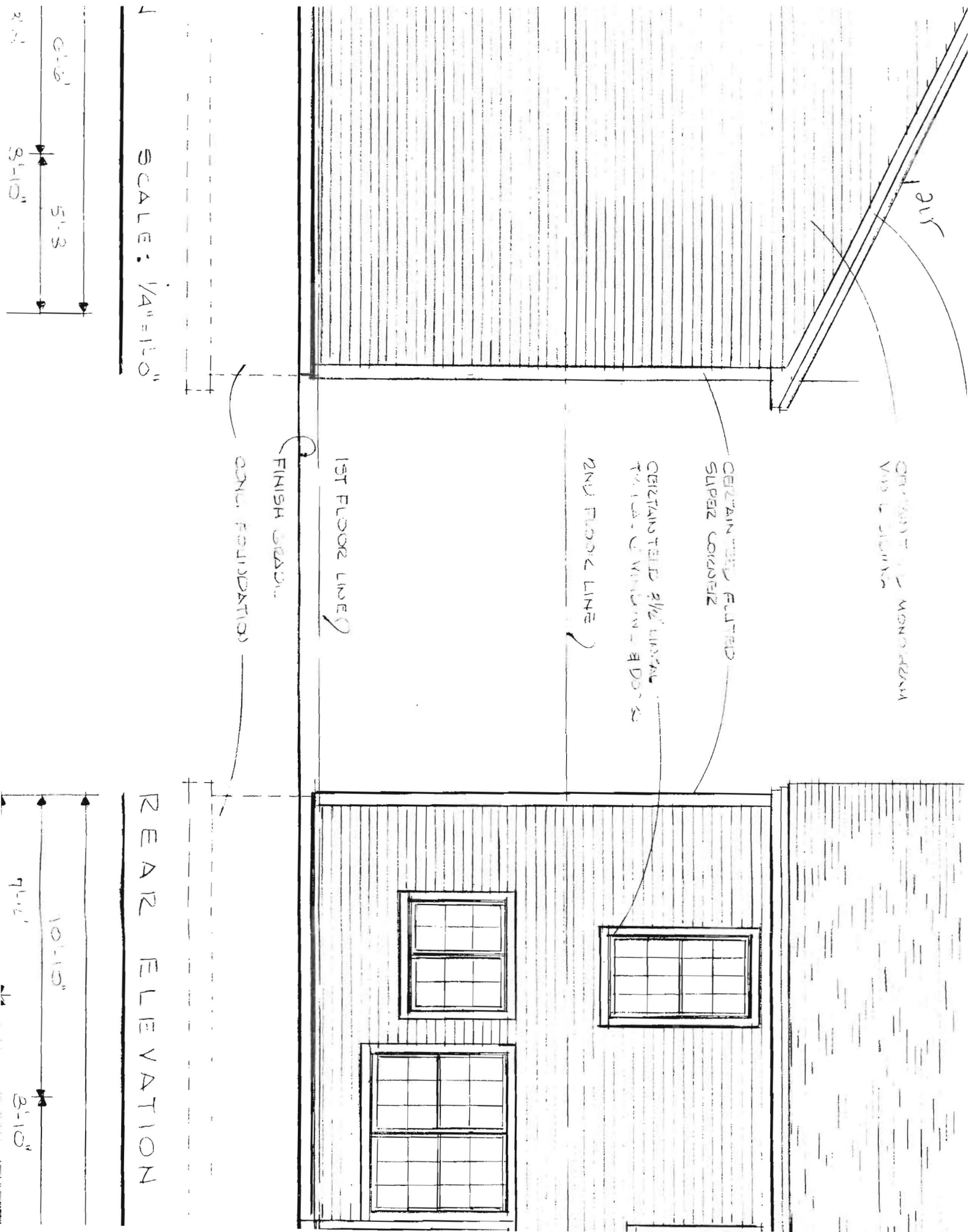

1 SCALE: 1/4" = 1'-0"

REAR ELEVATION

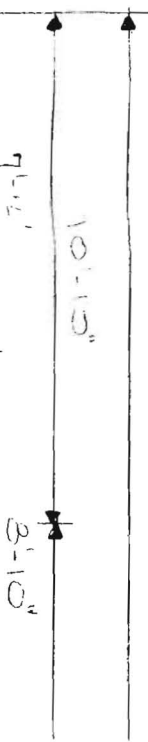
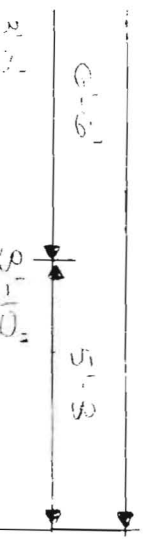

CONC. FOUNDATION

FINISH GRADE

1ST FLOOR LINE

2ND FLOOR LINE

CERTAINTEED FILTRATED SUPERZ CORNERZ

CERTAINTEED 2 1/2\"/>

CERTAINTEED 2 1/2\"/>

215

FOUNDATION PLAN SCALE: 1/4" = 1'-0"

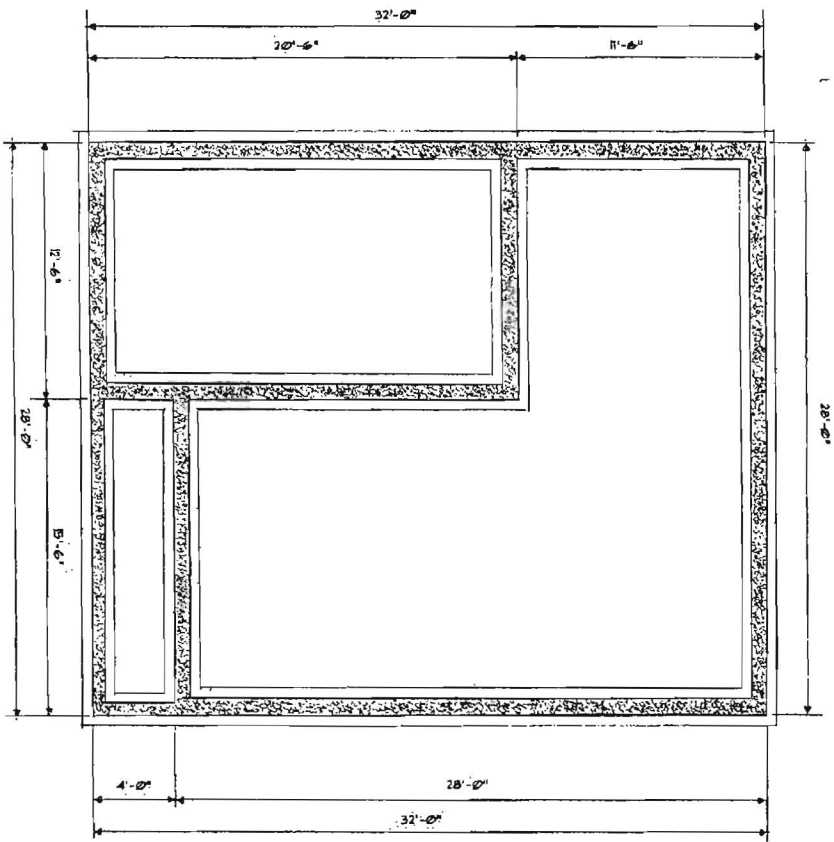

FIRST FLOOR PLAN SCALE: 1/4" = 1'-0"

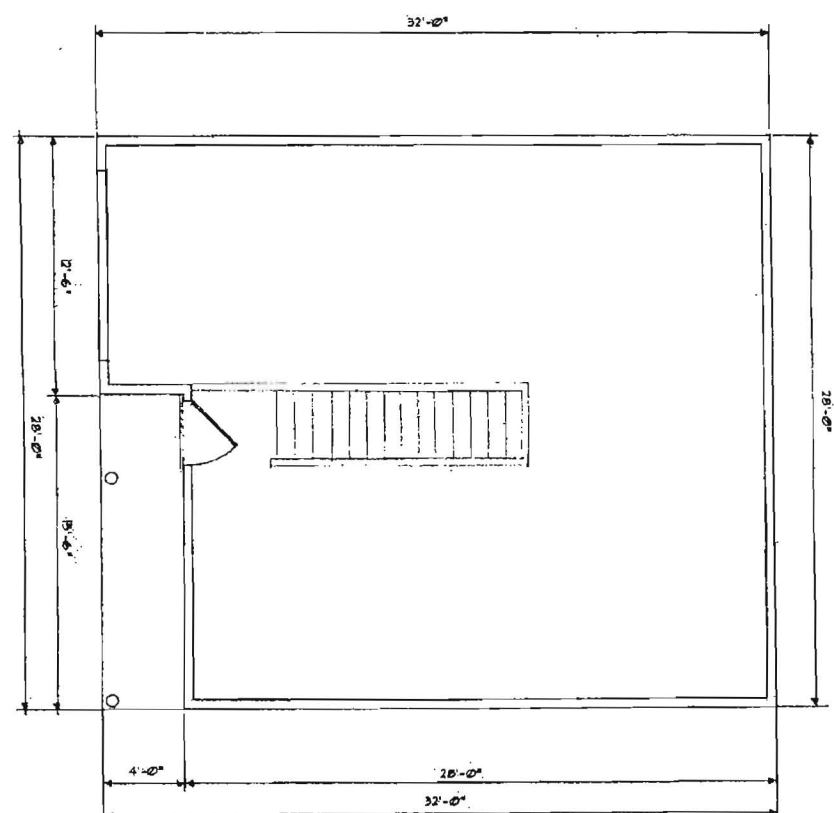

CROSS SECTION AT STAIR SCALE: 1/4" = 1'-0"

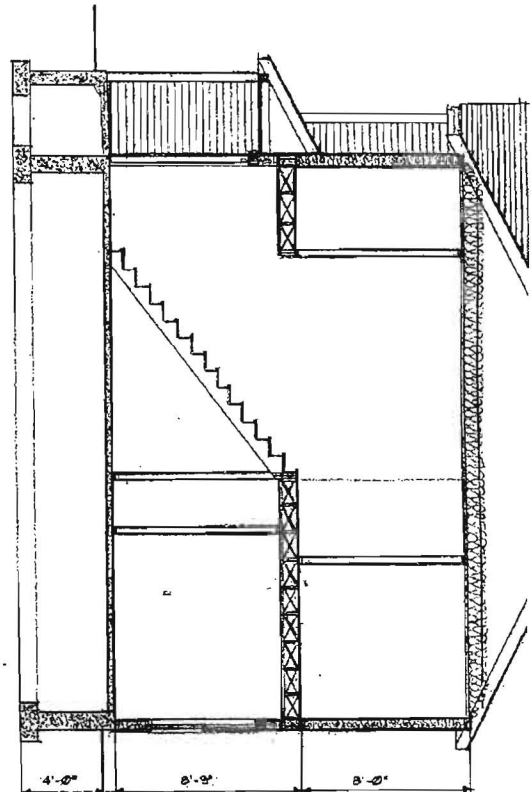

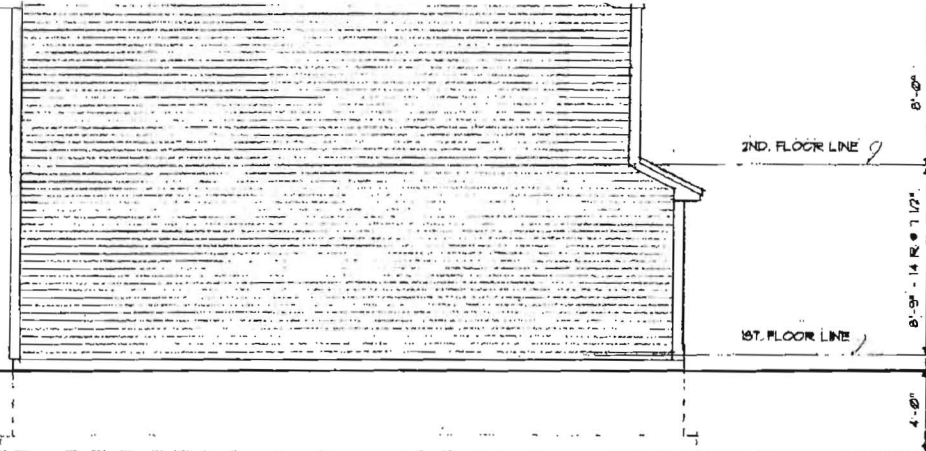

LEFT END ELEVATION

SCALE: 1/4" = 1'-0"

GAP TRIMBERLINE 2B SHINGLES OVER #5 ROOFING FELT 4 1/2" EXT. GRADE PLYUD AND OVER 6"-0" WIDE BITUMANE AT EYES & VALLEYS

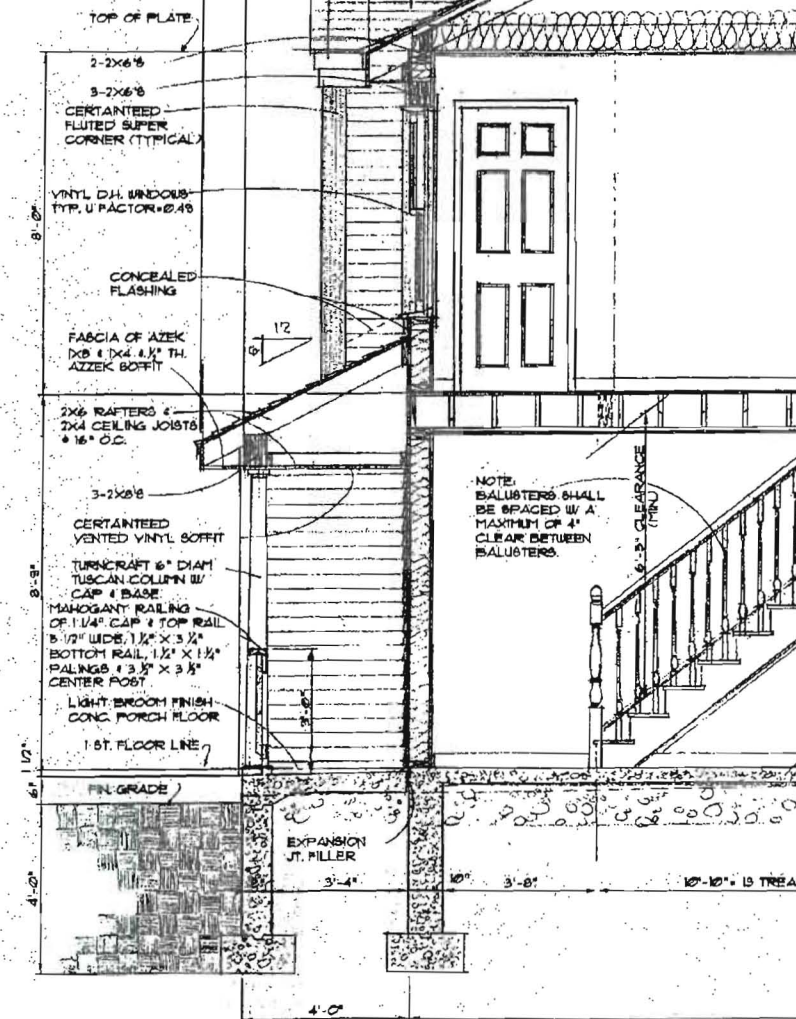

CROSS SECTION A

GENERAL NOTES

REVISIONS

THE

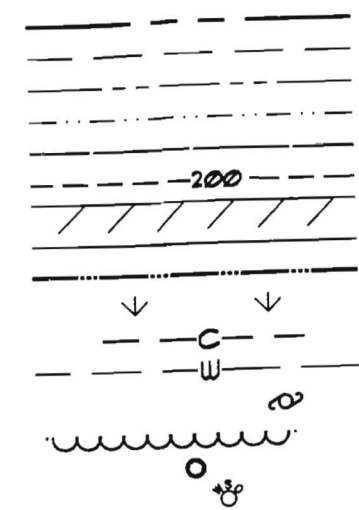
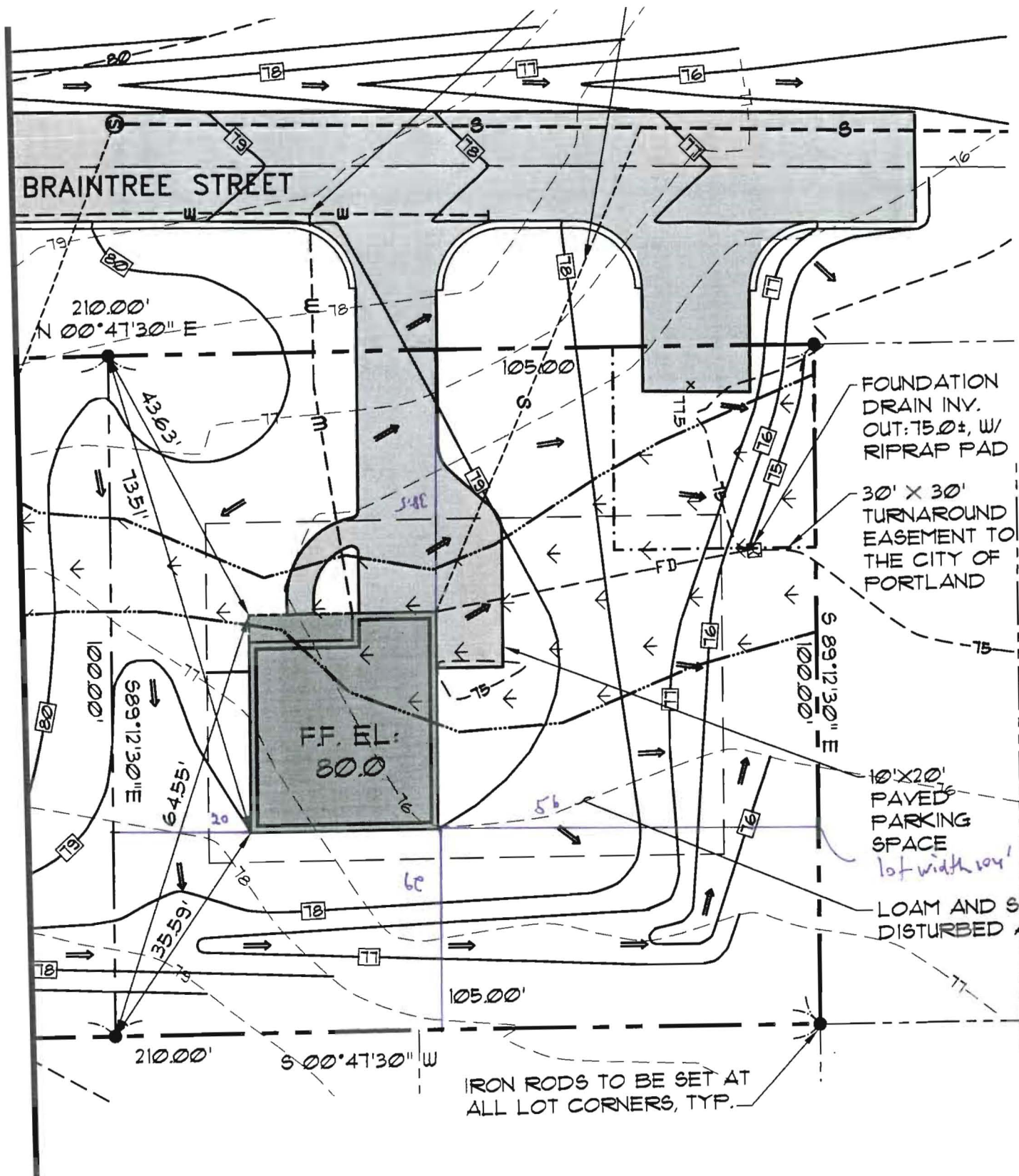

**PROPOSED**

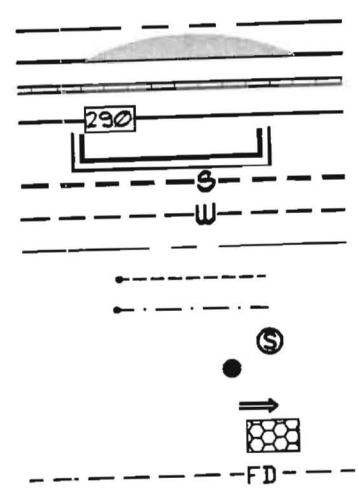

*Used for zoning*

