

PERMIT ISSUED

City of Portland, Maine - Building or Use Permit Application

389 Congress Street, 04101 Tel: (207) 874-8703, Fax: (207) 874-8716

Permit No: 02-1202	Issue Date: OCT 30 2002	CBL: 336 L022001
-----------------------	-----------------------------------	---------------------

Location of Construction: 99 Saugus St	Owner Name: Amabile Joseph M & Cathy L Jts	Owner Address: 99 Saugus St	Phone: 797-3832
---	---	--------------------------------	--------------------

Business Name:	Contractor Name: Mackie Builders	Contractor Address: 354 Long Plains Road Buxton	Phone: 2072290186
----------------	-------------------------------------	--	----------------------

Lessee/Buyer's Name	Phone:	Permit Type: Additions - Dwellings	Zone: R-2
---------------------	--------	---------------------------------------	--------------

Past Use: Single Family	Proposed Use: Single Family	Permit Fee: \$79.00	Cost of Work: \$7,200.00	CEO District: 1	10,005 #
----------------------------	--------------------------------	------------------------	-----------------------------	--------------------	----------

Proposed Project Description: Addition of 19' x 10' Mudroom	FIRE DEPT: <input type="checkbox"/> Approved <input type="checkbox"/> Denied	INSPECTION: Use Group: R3 Type: SB BOCA 1999
--	--	---

Signature:	Signature: <i>JMB</i> 10/30/02
------------	--------------------------------

PEDESTRIAN ACTIVITIES DISTRICT (P.A.D.)		
Action: <input type="checkbox"/> Approved <input type="checkbox"/> Approved w/Conditions <input type="checkbox"/> Denied	Signature: _____ Date: _____	

Permit Taken By: gad	Date Applied For: 10/21/2002	Zoning Approval	
-------------------------	---------------------------------	------------------------	--

1. This permit application does not preclude the Applicant(s) from meeting applicable State and Federal Rules. 2. Building permits do not include plumbing, septic or electrical work. 3. Building permits are void if work is not started within six (6) months of the date of issuance. False information may invalidate a building permit and stop all work..	Special Zone or Reviews <input type="checkbox"/> Shoreland <input type="checkbox"/> Wetland <i>NA</i> <input type="checkbox"/> Flood Zone <input type="checkbox"/> Subdivision <input type="checkbox"/> Site Plan Maj <input type="checkbox"/> Minor <input type="checkbox"/> MM <input type="checkbox"/> Date: <i>10/30/02</i>	Zoning Appeal <input type="checkbox"/> Variance <input type="checkbox"/> Miscellaneous <input type="checkbox"/> Conditional Use <input type="checkbox"/> Interpretation <input type="checkbox"/> Approved <input type="checkbox"/> Denied Date: _____	Historic Preservation <input checked="" type="checkbox"/> Not in District or Landmark <input type="checkbox"/> Does Not Require Review <input type="checkbox"/> Requires Review <input type="checkbox"/> Approved <input type="checkbox"/> Approved w/Conditions <input type="checkbox"/> Denied Date: <i>10/30/02</i>
--	---	---	--

CERTIFICATION

I hereby certify that I am the owner of record of the named property, or that the proposed work is authorized by the owner of record and that I have been authorized by the owner to make this application as his authorized agent and I agree to conform to all applicable laws of this jurisdiction. In addition, if a permit for work described in the application is issued, I certify that the code official's authorized representative shall have the authority to enter all areas covered by such permit at any reasonable hour to enforce the provision of the code(s) applicable to such permit.

SIGNATURE OF APPLICANT ADDRESS DATE PHONE

RESPONSIBLE PERSON IN CHARGE OF WORK, TITLE DATE PHONE

02-1202

All Purpose Building Permit Application

If you or the property owner owes real estate or personal property taxes or user charges on any property within the City, payment arrangements must be made before permits of any kind are accepted.

Location/Address of Construction: <u>99 Saugus St Portland</u>		
Total Square Footage of Proposed Structure <u>190 sq. ft.</u>	Square Footage of Lot <u>11000 sq</u>	
Tax Assessor's Chart, Block & Lot Chart# <u>336</u> Block# <u>L</u> Lot# <u>022</u>	Owner: <u>Joseph + Cathy Amabile</u>	Telephone: <u>797-3832</u>
Lessee/Buyer's Name (If Applicable)	Applicant name, address & telephone: <u>John Mackie 354 Long Plains Rd Buxton, Me. 04093</u>	Cost Of Work: \$ <u>7200.00</u> Fee: \$ <u>79-</u>
Current use: <u>Single Family Home</u>		
If the location is currently vacant, what was prior use: _____		
Approximately how long has it been vacant: _____		
Proposed use: <u>Mud room</u>		
Project description: <u>Addition 19' x 10' mud room on same tubes</u>		
Contractor's name, address & telephone: <u>Mackie Builders #229-0186 354 Long Plains Rd Buxton 04093</u>		
Who should we contact when the permit is ready: <u>John Mackie</u>		
Mailing address: _____		
We will contact you by phone when the permit is ready. You must come in and pick up the permit and review the requirements before starting any work, with a Plan Reviewer. A stop work order will be issued and a \$100.00 fee if any work starts before the permit is picked up. PHONE: <u>229-0186 or 797-637</u>		

IF THE REQUIRED INFORMATION IS NOT INCLUDED IN THE SUBMISSIONS THE PERMIT WILL BE AUTOMATICALLY DENIED AT THE DISCRETION OF THE BUILDING/PLANNING DEPARTMENT, WE MAY REQUIRE ADDITIONAL INFORMATION IN ORDER TO APPROVE THIS PERMIT.

I hereby certify that I am the Owner of record of the named property, or that the owner of record authorizes the proposed work and that I have been authorized by the owner to make this application as his/her authorized agent. I agree to conform to all applicable laws of this jurisdiction. In addition, if a permit for work described in this application is issued, I certify that the Code Official's authorized representative shall have the authority to enter all areas covered by this permit at any reasonable hour to enforce the provisions of the codes applicable to this permit.

Signature of applicant: <u>John C Mackie</u>	Date: _____
--	-------------

This is NOT a permit, you may not commence ANY work until the permit is issued. If you are in a Historic District you may be subject to additional permitting and fees with the Planning Department on the 4th floor of City Hall

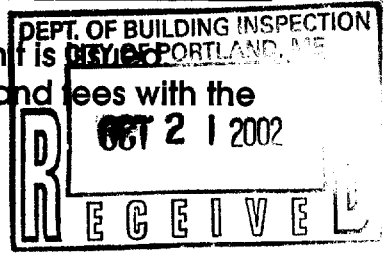

Application ID Number: 2-1202

Department: Building

Status: Approved with Conditions

Reviewer: Jeanine Bourke

Approval Date: 10/30/2002

Comments: 10/29/02 left vm with John Mackie about # of porch footings, rims, fastenings, graspable h-rail & nosing/riser on stairs.

Given On Date: 10/22/2002

OK to Issue Permit

Name	Date
Jeanine Bourke	10/30/2002
	Date 2

Conditions Section:

Add New Condition from

Add New Condition

Delete Condition

Application approval based upon information provided by applicant. Any deviation from approved plans requires separate review and approval prior to work.

Per contractor, the perimeter rims on the 10' slides will be doubled, rim will be lagged to house, treads will have min. Required nosing, closed riser, and graspable h-rail. Stairs will be located at the front off the mud room

Create Date: 10/22/2002 By: gad Update Date: 10/30/2002 By: lmb

Buttons: Delete, Save, Close

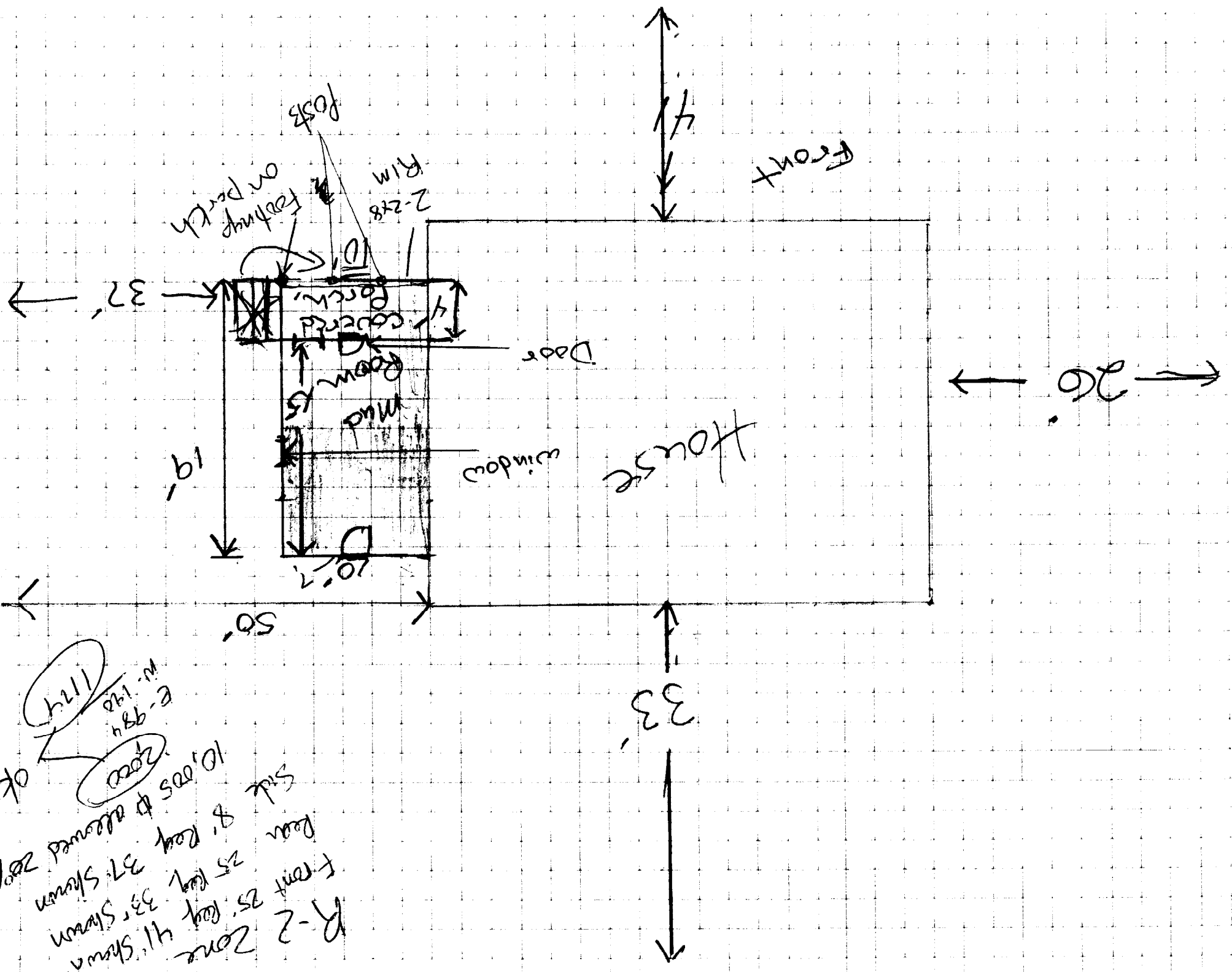

R-2 Zone
 Front 25' Roof 33' Shown
 Rear 8' Roof 25' Shown
 Side 10' Roof to allowed 20'6"
 20'6"
 E-984
 M-148
 1174
 OK

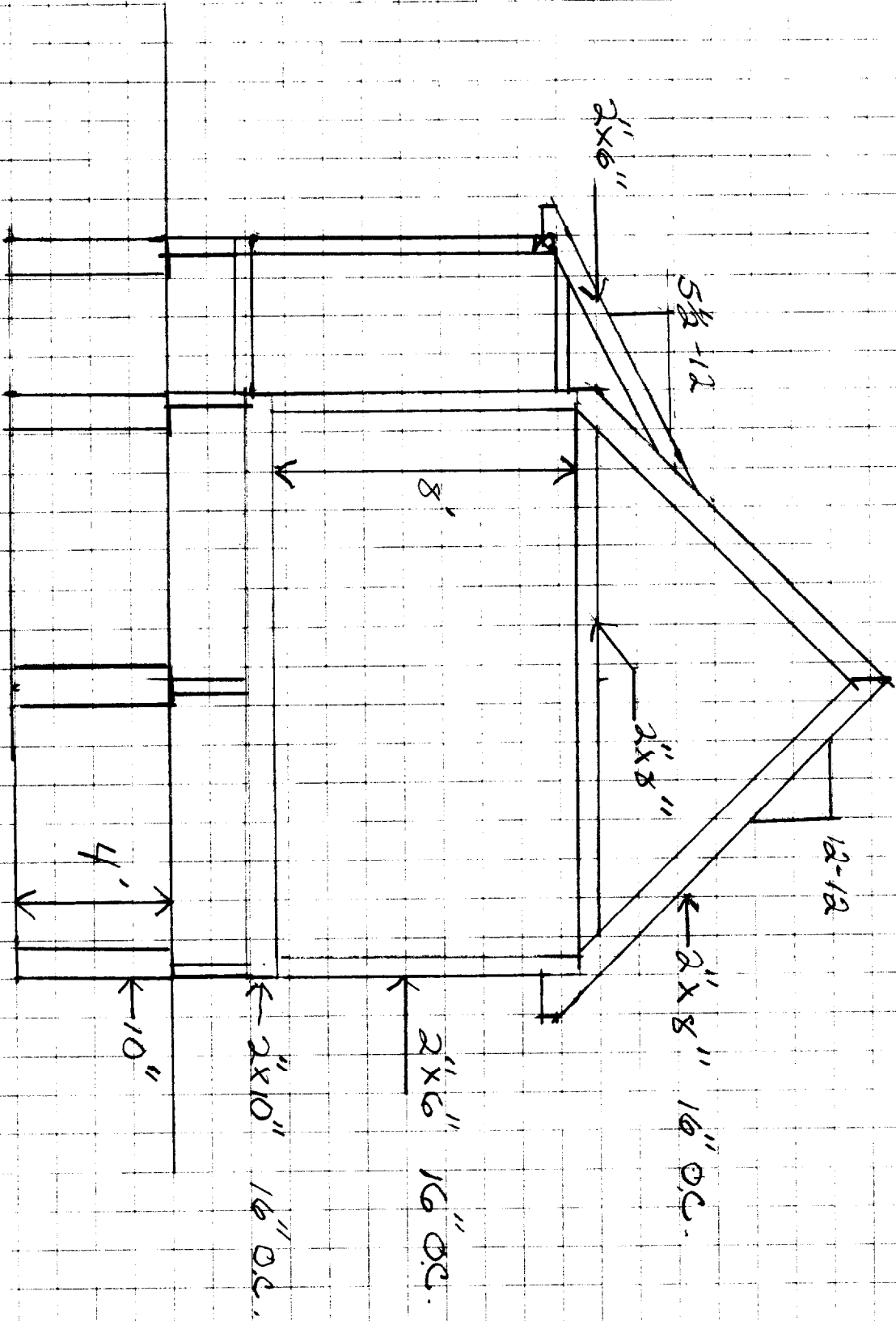

2x6"

5/12

8'

2x8"

12/12

2x8" 16" O.C.

2x6" 16" O.C.

2x10" 16" O.C.

10"

4"

Floor Framing
Sawna tubes

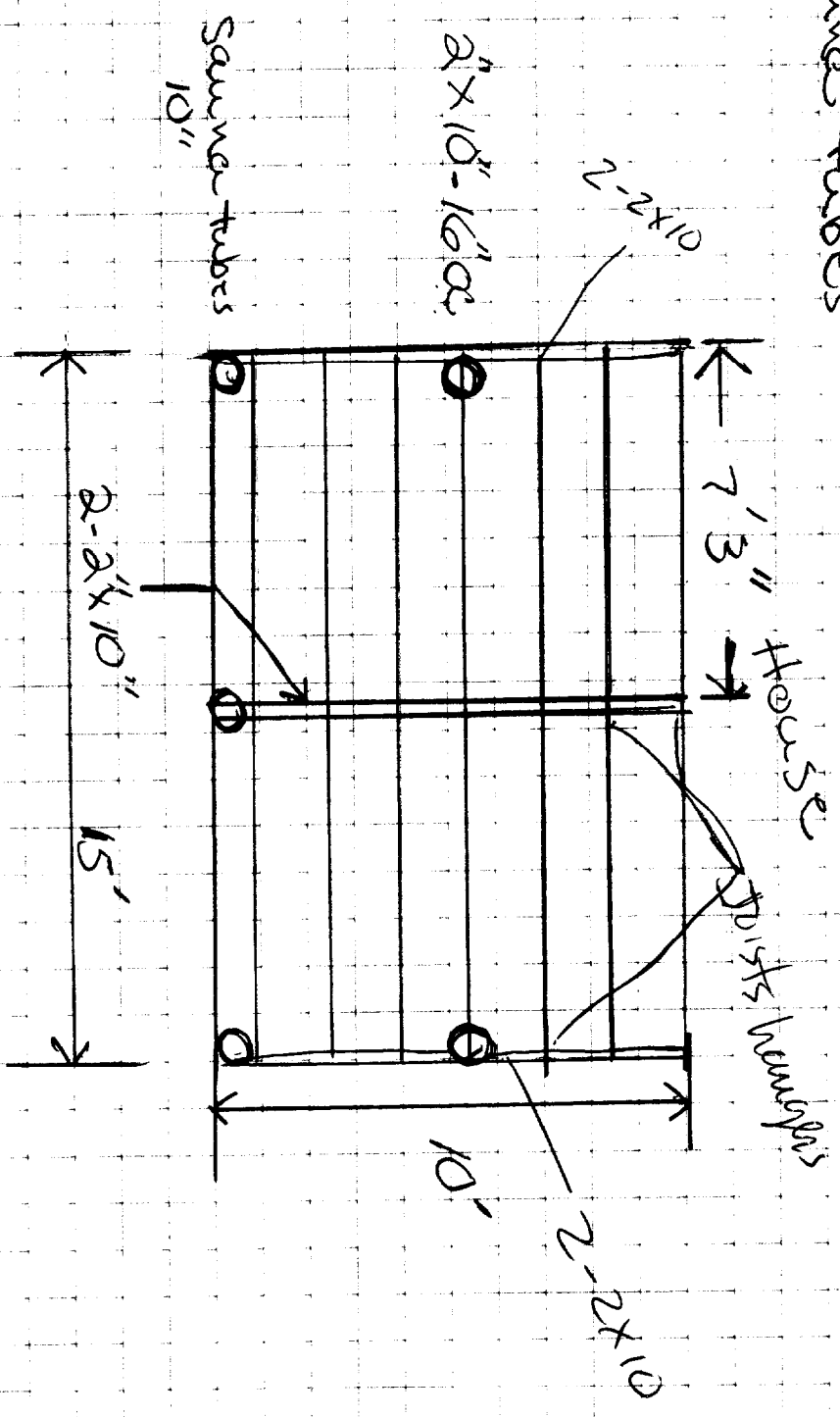

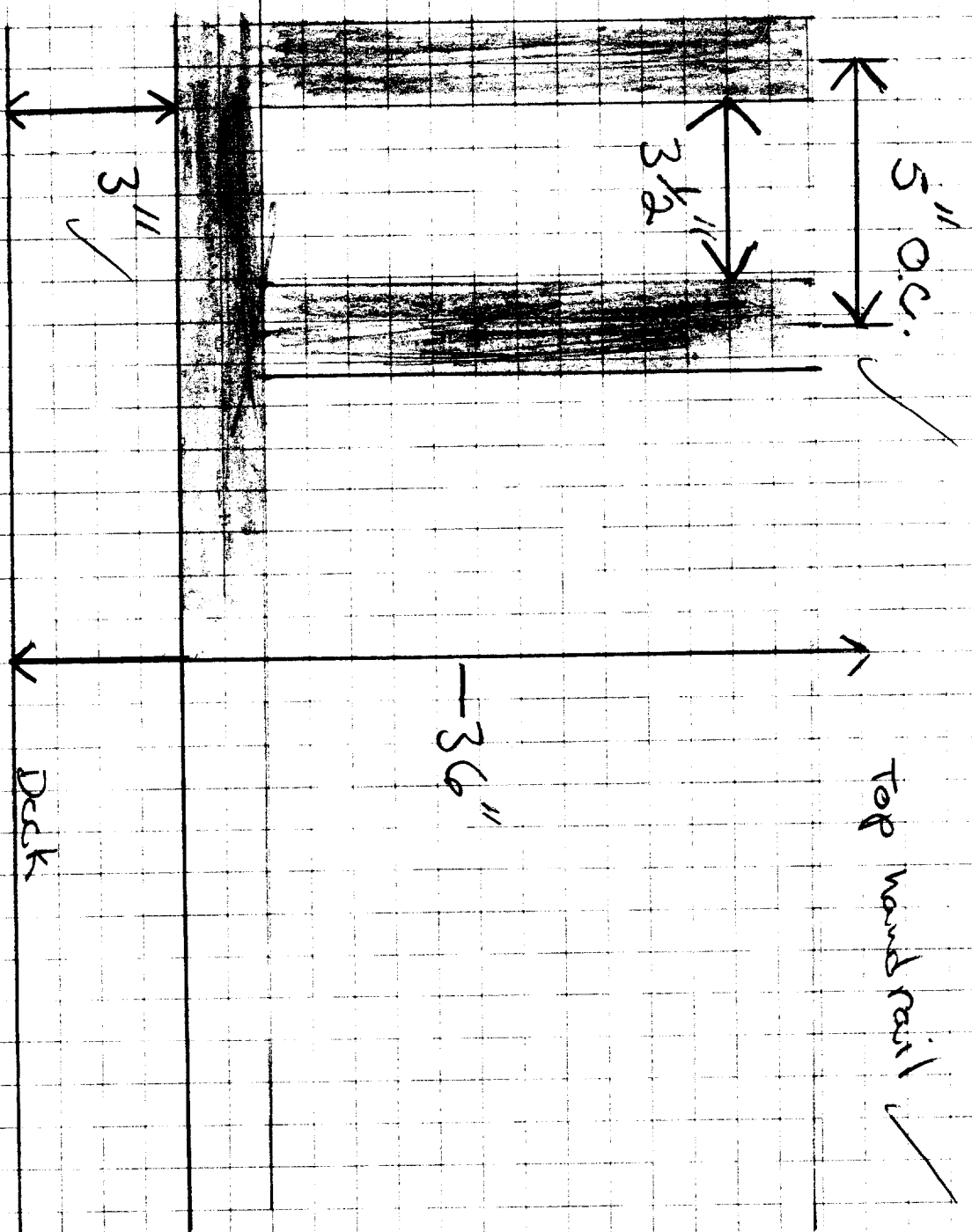

Hand rail & Balusters

Top handrail

Graspable
Will attach
with returns

Mackie Builders

354 Long Plains Rd.
Buxton, Me. 04093
mackbuildr@adelphia.net

Phone: 207-727-6371
Cell: 207-229-0186
FAX: 207-727-3379

Specifications for Amabile Mud Room (addition at 99 Saugus St.)

- Sauna Tubes 10" dug to 4 feet. ✓
- Deck framing 2" x 10". ✓
- Decking 3/4" T&G plywood. ✓
- Exterior walls 2" x 6" framing. ✓
- Wall sheathing 1/2" OSB. ✓
- Collar ties clear span 2" x 8". ✓
- Roof framing 2" x 8". ✓
- Roof sheathing 1/2" plywood. ✓

Farmer's Porch (constructed on front of mud room)

- Deck 4' x 10'. ✓
- Framing 2" x 8" PT. ✓
- Decking 5/4" PT. ✓
- Post 4" x 4" PT. ✓

Roof framing of Farmer's Porch

- Rafters 2" x 6". ✓
- Roof sheathing 1/2" plywood. ✓
- Collar ties 2" x 4". ✓
- Carrying beam 2" x 8".

DISPLAY THIS CARD ON PRINCIPAL FRONTAGE
CITY OF PORTLAND

PERMIT

PERMIT ISSUED
OCT 30 2002
Permit Number: 021202
CITY OF PORTLAND

Please Read Application And Notes, If Any, Attached

This is to certify that Amabile Joseph M & Cathy s/Mack
has permission to Addition of 19' x 10' Mudroo
AT 99 Saugus St L 336 L022001

provided that the person or persons, firm or corporation accepting this permit shall comply with all of the provisions of the Statutes of Maine and of the ordinances of the City of Portland regulating the construction, maintenance and use of buildings and structures, and of the application on file in this department.

Apply to Public Works for street line and grade if nature of work requires such information.

Notification of inspection must be given and work on permit must be completed before this building or part thereof is occupied or enclosed-in. **HEAR NOTICE IS REQUIRED.**

A certificate of occupancy must be procured by owner before this building or part thereof is occupied.

OTHER REQUIRED APPROVALS

Fire Dept. _____
Health Dept. _____
Appeal Board _____
Other _____
Department Name _____

Jeannie Bouke 10/30/02
Director - Building & Inspection Services

BUILDING PERMIT INSPECTION PROCEDURES

Please call 874-8703 or ~~874-8693~~ to schedule your inspections as agreed upon

Permits expire in 6 months, if the project is not started or ceases for 6 months.

The Owner or their designee is required to notify the inspections office for the following inspections and provide adequate notice. Notice must be called in 48-72 hours in advance in order to schedule an inspection:

By initializing at each inspection time, you are agreeing that you understand the inspection procedure and additional fees from a "Stop Work Order" and "Stop Work Order Release" will be incurred if the procedure is not followed as stated below.

JB **Pre-construction Meeting:** Must be scheduled with your inspection team upon receipt of this permit. Jay Reynolds, Development Review Coordinator at 874-8632 must also be contacted at this time, before any site work begins on any project other than single family additions or alterations.

- AMM **Footing/Building Location Inspection:** Prior to pouring concrete
- N/A **Re-Bar Schedule Inspection:** Prior to pouring concrete
- N/A **Foundation Inspection:** Prior to placing ANY backfill
- AMM **Framing/Rough Plumbing/Electrical:** Prior to any insulating or drywalling
- AMM **Final/Certificate of Occupancy:** Prior to any occupancy of the structure or use. NOTE: ~~There is a \$75.00 fee per inspection at this point.~~

Certificate of Occupancy is not required for certain projects. Your inspector can advise you if your project requires a Certificate of Occupancy. All projects DO require a final inspection

AMM **If any of the inspections do not occur, the project cannot go on to the next phase, REGARDLESS OF THE NOTICE OR CIRCUMSTANCES.**

N/A **CERIFICATE OF OCCUPANICES MUST BE ISSUED AND PAID FOR, BEFORE THE SPACE MAY BE OCCUPIED**

Angela B. Mackie
Signature of applicant/designee

10/30/02
Date

Joanie Bonta
Signature of Inspections Official

10/30/02
Date

CBL: 336-L-22 Building Permit #: 021202

11/4/02 - Contractor cancelled - Not READY for

11/18/02 - Close in inspection. No ELECTRICAL INSTALLED All else OK. JL

12-5-02 Did interior electrical OK to close now
stairs on & OK Need
graspable rail.



CITY OF PORTLAND, MAINE
Department of Building Inspections

Oct. 21 2002

Received from Marlene Briedes

Location of Work 99 Douglas St

Cost of Construction \$ _____

Permit Fee \$ 1,500.00

Building (IL) Plumbing (I5) Electrical (I2) Site Plan (U2)

Other _____

CBL: 336 2002

Check #: 04 0404 Total Collected \$ 1,500.00

THIS IS NOT A PERMIT

No work is to be started until PERMIT CARD is actually posted upon the premises. Acceptance of fee is no guarantee that permit will be granted. PRESERVE THIS RECEIPT. In case permit cannot be granted the amount of the fee will be refunded upon return of the receipt less \$10.00 or 10% whichever is greater.

WHITE - Applicant's Copy
YELLOW - Office Copy
PINK - Permit Copy

Key