

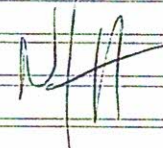

Permitting and Inspections Department

Fire Alarm Permit Application

Construction Address: 175 Industrial Way	
Total Square Footage of Proposed Structure: 14,000	
Tax Assessor's Chart, Block & Lot Chart# Block# Lot# [] [] []	Applicant Name: Norris Inc. Address: 2257 West Broadway South Portland, ME. 04106 Phone: 207-883-3473 Email: melissap@norrisinc.com
Cost of Work: \$ 16,000	Contractor Name (if different): BH Milliken Address: 235 Presumpscot St. Portland, ME. 04103 Phone: 207-879-0877 Email: eb@bhmilliken.com
Lessee/Owner Name (if different): Immucell Corporation Address: 56 Evergreen Dr Portland ME Phone: 207. 878. 2770 Email: mbrigham@immucell.com	Contractor Name (if different): BH Milliken Address: 235 Presumpscot St. Portland, ME. 04103 Phone: 207-879-0877 Email: eb@bhmilliken.com
Current use (i.e. single family): Warehouse / shipping	
If vacant, what was the previous use? []	
Proposed specific use: Factory and Industrial	
Is property part of a subdivision? If yes, name: NO	
Project description: install a new addressable fire alarm system.	
Life Safety Code Occupancy Classification: F-1 Factory and Industrial Moderate Hazard	
Is this new work or a renovation to an existing system? new	
Is the top occupiable floor of the building greater than 75 feet above the lowest level of Fire Department access (high-rise)? No	
Name of company providing programming and certification of system*: Norris Inc.	
Electrical permit #: ELEC2019-02218	
Will a master box be installed? <input type="radio"/> Yes <input checked="" type="radio"/> No If yes, complete all items for approval):	
AES approved installing contractor: []	
Documentation of AES approval: []	
Property Owner: [] 	
Property Owner Billing Address: []	
Property common name: []	
E-911 address for protected premises: []	
Emergency contact phone: [] Additional emergency contact phone: []	
Number of stories protected: 1 plus more	
Is the building protected by a supervised, automatic sprinkler system? <input checked="" type="radio"/> Yes <input type="radio"/> No	
Name of person to contact when the permit is ready: Melissa Peters--Norris Inc.	
Address: same as above	
City, State & Zip: []	
Email Address: melissap@norrisinc.com	Phone: []

*For a list of approved fire alarm companies, see www.portlandmaine.gov/1486/Approved-Fire-Alarm-Companies
389 Congress Street, Room 315/Portland Maine 04101/www.portlandmaine.gov/tel: 207-874-8703/fax: 207-874-8716



Norris Inc.

PO Box 2551
2257 West Broadway
South Portland, ME 04106

1-800-370-3473
Fax 207-879-0540



www.norrisinc.com
Reviewed for Code Compliance
Permitting and Inspections
Department
Approved
02/10/2020

Please complete this form and return to Norris Inc.

Building Owner Information Form

Job Name:

Project #

Electrical Contractor:

NFPA requires this information for proper documentation.

The contractor must provide all of the requested information below before ANY equipment can be released.

Electrical Contractor Contact:

Estimated Date Equip. Needed:

Estimated Finals Date:

Building Owner:

Job Site Address:

City:

State:

Zip:

Customer Contact:

Phone:



Norris Inc.

PO Box 2551
2257 West Broadway
South Portland, ME 04106

1-800-370-3473
Fax 207-879-0540



Thank you for your cooperation.

Please advise the building owners that if this system is equipped with a digital communicator, then they MUST also make monitoring arrangements prior to a certificate of occupancy.

Norris Inc will attempt to contact the building owners.



Norris Inc.

PO Box 2551
2257 West Broadway
South Portland, ME 04106

1-800-370-3473
Fax 207-879-0540



STOP!

**THIS COPY IS FOR YOUR ELECTRICIAN
ON THE JOBSITE**

PLEASE BE SURE THIS COPY IS FORWARDED

- 1.) A riser diagram is enclosed. DO NOT USE THE ENGINEER'S RISER SHOWN ON THE PLANS. If there is any information that you question, call us immediately.**
- 2.) YOU MUST CALL AT LEAST FIVE DAYS IN ADVANCE TO SCHEDULE FINAL CONNECTION ASSISTANCE.**
- 3.) All wires must be labeled and clear of any grounds, shorts or opens, and must maintain polarity throughout. Meter out all circuits before calling for final connection assistance. If applicable verify End of Line resistors are in place.**
- 4.) If using shielded cable, the drain wires must be connected and fully insulated, so that neither the shield or the drain wire touches the backbox.**
- 5.) Unless special arrangements are made, we will make one final job site visit. If a special visit is required for an elevator inspection or partial occupancy, then additional charges may if prior arrangements were not made. Call your customer service representative if needed.**
- 6.) If you have any defective or left over parts, DO NOT WRITE ON THEM OR THE BOXES. Save the original box, all mounting hardware and instructions. Returns that do not conform to this practice will not be accepted for credit.**
- 7.) If the system is being monitored through a digital communicator, please see information on the next page.**

**IMPORTANT INFORMATION FOR THE BUILDING OWNERS
SPECIAL NOTE REGARDING ALARM MONITORING SERVICES**

Included with your alarm system package is a digital communicator, which sends coded messages to a private 24 hour central station if your alarm system is activated. This is a code requirement for most fire alarm systems. As a service to our customer, we offer central station monitoring services from our local UL Listed central station at extremely competitive rates.

If the central station monitoring contract is purchased through Norris Inc. prior to our scheduled start up; we will connect, program, and test the communicator at no additional charge.

Should the building owners decide to obtain monitoring services from another company, then the cost for programming and testing the communicator will be the sole responsibility of the firm they have contracted with. Furthermore, if programming changes are made to the system by persons other than Norris Inc. technicians, then the company performing the changes shall be solely liable for any personal injury or loss of life or damage to, or loss of property arising out of the use of or inability to use the system and it shall result in a waiver of any system warranties.

We appreciate that you understand the delicate nature of this life safety and/or security system and realize that serious problems may arise when modifications to the system are made, including very simple programming changes.

Call Norris Inc. at 1-800-370-FIRE (3473) to make arrangements for central station monitoring services.



Norris Inc.

PO Box 2551
2257 West Broadway
South Portland, ME 04106

1-800-370-3473
Fax 207-879-0540



www.norrisinc.com
Reviewed for Code Compliance
Permitting and Inspections
Department
Approved
02/16/2020

SUBMITTAL PACKAGE

Project: Immucell

System: Fire Alarm

Submitted by: Norris Inc.

2257 West Broadway

South Portland, Maine 04106

Telephone: 1-800-370-3473

Submittal Date: 1/16/2020



Norris Inc.

PO Box 2551
2257 West Broadway
South Portland, ME 04106

1-800-370-3473
Fax 207-879-0540



Company Profile

“We are extremely proud to represent the highest quality manufacturers integrating life safety, alarm, and communication systems throughout northern New England.”

—Bradford Norris, President—

Mission Statement

Provide quality engineered systems, exceptional service.

Goal

Learn...Continually Improve...Exceed Expectations

Founded in 1979, Norris Inc. has grown to become northern New England’s leading integrated system contracting and supply company. Norris Inc. is an innovated proactive organization with extensive experience in integration interdisciplinary building management systems. Our local and national affiliations assure that your project will be done properly regardless of size. Representing leading manufacturers, our comprehensive projects provide outstanding quality, reliability, and performance... Surpassing customer application requirements and exceeding the stringent requirements of Underwriters Laboratories, National Fire Protection Association and other codes.

We maintain an exceptional level of quality and provide the highest levels of customer service. Our knowledgeable technical support will insure the great service you deserve.

Whether your needs involve industrial, commercial, institutional, or educational applications, you can trust that Norris Inc. has the complete resources it takes to provide the right solution, right away.

LIMITED WARRANTY

Norris Inc. warrants that the products of its manufacturers shall be free from defects in materials or workmanship as warranted by the manufacturer which is typically for a one (1) year period from the completed installation date, but not always. The completed installation date will be the date when the end-user was able to begin using or started using the product(s) or the system, whether partially or in its entirety. For projects that have a specification or bid instructions to follow which contains specific warranty requirements, Norris Inc. will always honor the warranty terms exactly as specified in the project's specifications or bid documents, which may be more or less in coverage and duration than the manufacturer's warranty. In performing hundreds of projects per year with thousands of different products it is impossible for Norris Inc. to track the terms and details of specified or individual product warranties. Therefore, Norris Inc. will request that the owner's representative provide these special warranty details when the warranty work is requested; otherwise a standard one (1) year warranty on the equipment will be honored. The manufacturer's warranty is for equipment only and does not include any labor and/or shipping costs. All warranties provided by Norris Inc. are limited with the same limitations included with the manufacturer's warranty which is included in the manuals of the products being provided.

The warranty will apply only if such goods have been properly installed, are subject to normal proper use and have not been modified in any manner whatsoever. Upon return of the defective product, Norris Inc. will, at its sole discretion, either repair or replace, at no cost, such goods determined to have a defect in materials or workmanship. In cases of a warranty repair, Norris Inc. will use its sole discretion to determine if a suitable replacement part can be provided on loan while the repairs are being performed.

All warranty work is performed during regular business hours. If emergency warranty work is required, the customer will pay the difference between the emergency service bill and our normal hourly charges.

Norris Inc.'s limited warranty does not apply to those products that are damaged due to misuse, abuse, negligence, exposure to adverse environmental conditions, acts of God, or have been modified in any manner whatsoever.

Norris Inc.'s standard terms and conditions are provided with our invoices. Those Terms and Conditions shall be provided upon request.

NORRIS INC. SHALL NOT UNDER ANY CIRCUMSTANCES BE LIABLE FOR ANY INCIDENTAL OR CONSEQUENTIAL DAMAGES ARISING FROM LOSS OF LIFE AND/OR PROPERTY OR OTHER DAMAGE OR LOSSES OWING TO THE FAILURE OF NORRIS INC. PRODUCTS BEYOND THE COST OF REPAIR OR REPLACEMENT OF ANY DEFECTIVE PRODUCTS.

NORRIS INC. MAKES NO WARRANTY OF FITNESS OR MERCHANTABILITY AND NO OTHER WARRANTY, ORAL OR WRITTEN, EXPRESS OR IMPLIED AS ALLOWED TO THE FULLEST EXTENT OF THE LAW.

OUR CONTINUOUS COMMITMENT TO OUR ENVIRONMENT

At Norris Inc, we are proudly committed to continuous environmental improvement for a sustainable future and to develop strong partnerships within our community.

Our mission while running our operations is to do everything within our power to improve the environmental quality of our world and to work together to create a clean and safe place to live in and work in for future generations.

We will incorporate and promote green practices within our operations with policies to support it, a system of rewarding those that fully embrace it and then will regularly review our practices for continuous improvement.

We will establish policies, make investments in technologies and set the example in our own operations to include our ongoing commitment to go paperless and making it a requirement to Reuse, Reduce, & Recycle, to turn off unneeded lights, to not allow our vehicles to idle, to encourage carpooling and to utilize practical energy efficient transportation.

We will always be 100% compliant with all applicable environmental laws and regulations and will report any violations.

We will remain committed to working locally and whenever possible to sell and use locally manufactured products.

We will insist that every purchase we make will include a review of its environmental impact with a very high priority to selecting the greenest products and services available.

We will remain committed to selling low energy products. This includes promoting wireless technologies, using existing wire infrastructure in our installations, promoting solar powered devices, using our Remote Services in lieu of on-site service calls and performing calculations to minimize power supply and battery needs.

We will educate our employees and customers to illustrate that green practices and purchases are almost always less costly in the long run.

We will support and give priority to organizations that show the strongest commitment to the environment.

We will actively encourage and promote the same responsible green practices that we utilize in the work place to our employees for use in their everyday personal lives.

REMOTE INTERNET CONNECTIONS

As an added service to our customers and in order to facilitate the commissioning of the system(s) being provided within this submittal and then later to provide warranty support Norris Inc. may (at Norris Inc's option) use internet connections to gain access to the system(s) being provided. Many methods can be used, but the most popular is utilizing software named LogMeIn. This software or any other method used to connect to the customer's network will allow Norris Inc's technicians the ability to get onto the programming and diagnostic levels of the system(s) being provided via the building owner's or tenant's data network and program, diagnose or make needed changes to the operation of the system(s). This will provide a better working atmosphere to perform programming from a controlled environment without the disruptions of a construction job-site and allow fast and efficient trouble shooting and/or servicing if problems should occur later. Acceptance of this submittal by those approving it shall constitute an acceptance and approval to perform the work necessary to install and/or enable these network connections if Norris Inc. chooses to do so. It is the sole responsibility of the submittal approvers to advise the building owners and/or tenants that Norris Inc. has the ability to gain access to their network. At the specific request of those approving this submittal or the contractor that Norris Inc. is working for the building owners or tenants that own the network, Norris Inc. can remove or disable the ability to connect to the building's network. However, leaving it in place will allow for quicker and more cost effective service when it is needed. Under absolutely no circumstances shall Norris Inc, its principals, employees, or heirs to be held responsible for any losses incurred as a result of this network connection or the inability for the network connection to operate as expected.



Reviewed for Code Compliance
Permitting and Inspections
Department
April 10, 2020

This is to certify that

NORRIS, INC.

is an authorized Premier Engineered Systems Distributor for
NOTIFIER

During the year of 2020

Richard Bauer
Vice President Sales

ESD Since 1987



Reviewed for Code Compliance
Permitting and Inspections
Department
Approved: 02/10/2020

Immucell 175

Date:

1/16/2020

Project #:

1551

Contractor:

BH Milliken
(207) 879-1877

Equipment List

<u>Manufacturer</u>	<u>Part Number</u>	<u>Description</u>
NOTIFIER	NFW-100X	ADDRESSABLE FIRE ALARM CONTROL PANEL
SR COMPONENTS	804R8	SILVER SATIN 8' PLUG - PLUG
SR COMPONENTS	RJ31X	UL 8P8C RJ31X JACK
SIGMASTEK	SP1212	12V 12AH BATTERY
NOTIFIER	NOTBG12LX	ADDRESSABLE PULL STATION.
SYSTEM SENSOR	BKCO1224TR	CO DETECTOR
NOTIFIER	NP200	ADDRESSABLE PHOTO DETECTOR, W/BASE.
NOTIFIER	NP200R	REMOTE TEST CAPABLE SMOKE DETECTOR
NOTIFIER	DNR	ADDRESSABLE DUCT DETECTOR
NOTIFIER	DST3	SAMPLING TUBE
NOTIFIER	RTS151	REMOTE TEST STATION
NOTIFIER	NC100R	ADDRESSABLE RELAY MODULE
NOTIFIER	NMM100P	ADDRESSABLE MINI MODULE
SYSTEM SENSOR	P2RL	HORN STROBE, WALL, RED
SYSTEM SENSOR	SRL	STROBE, WALL, RED
SYSTEM SENSOR	P2RK	HORN STROBE, WEATHER PROOF, RED
SYSTEM SENSOR	SRK	STROBE, WEATHER PROOF, RED
SPACE AGE	ELOCKFA	FIRE CIRCUIT LOCK OUT KIT
SPACE AGE	SSU00690	FIRE ALARM RECORDS CABINET
KNOX	KNOX3262	KNOX BOX, BLACK, SURFACE



Reviewed for Code Compliance
Permitting and Inspections
Department
April 10, 2020

 **NOTIFIER**[®]
by Honeywell

NFW-100X Intelligent Addressable FACP with Communicator

General

The **FireWarden-100X (NFW-100X)** is the latest intelligent addressable Fire Alarm Control Panel (FACP) within the FireWarden Series. The NFW-100X comes with a pre-installed communicator and supports up to 198 addressable devices (99 detectors and 99 modules). With an extensive list of powerful features, the NFW-100X programs just like FireWarden-100 products, yet fits into applications previously served only by conventional panels.

The pre-installed IPOTS-COM is a dual technology (POTS and IP) communicator. The POTS transmits system status (alarms, troubles, AC loss, etc.) to a Central Station via the public switched telephone network. The IP communicator's internet monitoring capability sends alarm signals over the Internet saving the monthly cost of two dedicated business telephone lines. Although not required, the secondary telephone line may be retained providing backup communication over the public switched telephone line. Optional cellular reporting is available using the CELL-MOD or CELL-CAB-N.

Remote and local programming of the control panel is possible using the FS-Tools Upload/Download utility. Programming databases can be uploaded/downloaded via the panel's USB port (and USB cable) or via an ethernet connection using the IPOTS-COM communicator. The USB port also allows for the download or upload of the entire program, history file, walk-test data, current status and system voltages by means of a USB flash drive.

The power supply and all electronics are contained on a circuit board supported on a new quick install chassis and housed in a metal cabinet. Available accessories include local and remote upload/download software, remote annunciators, and reverse polarity/city box transmitter (4XTM).

Features

- Listed to UL Standard 864, 10th edition
- Pre-installed IPOTS-COM Ethernet IP and POTS (Plain Old Telephone Service) Central Station Communicator over AlarmNet
- Optional CELL-MOD or CELL-CAB-N GSM Central Station Communicator over AlarmNet®
- Automated activation of the NFC-50/100 Emergency Command Center
- NFC-FFT Firefighter Telephone option
- Compatible with SWIFT® wireless devices
- Auto-programming (learn mode) reduces installation time. Reports two devices set to the same address
- Four built-in, independently programmable Style Z (Class A) or Style Y (Class B) NAC circuits
- Selectable strobe synchronization for System Sensor, Wheelock, and Gentex devices
- Notification Appliance Circuit End of Line resistor matching
- Four programmable function keys for ease of maintenance
- Two programmable relays and one fixed trouble relay
- Built-in Programmer
- Integral 80-character LCD display with backlighting
- Real-time clock/calendar with automatic daylight savings control
- History file with 1,000 event capacity
- Addressable sounder base compatibility
- Control module delay timer
- Automatic detector sensitivity testing (NFPA 72 compliant)
- Automatic device type-code verification
- Point trouble identification
- Waterflow selection per module point
- Alarm verification selection per detector point
- Maintenance alert warns when smoke detector dust accumulation is excessive

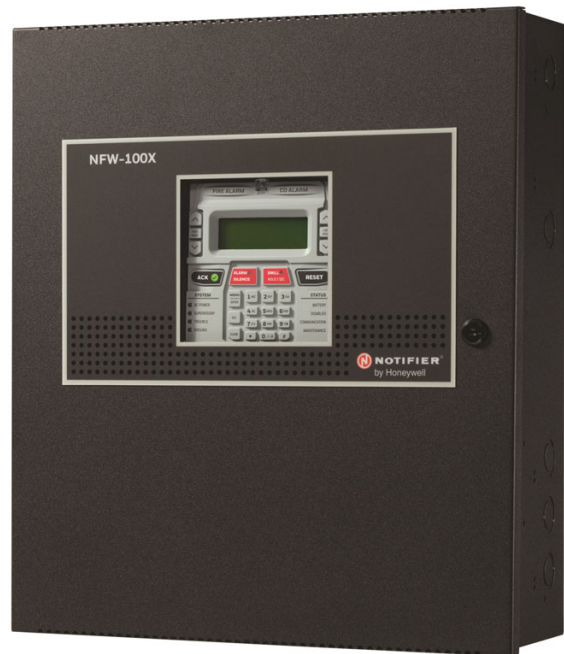

- One-person audible or silent walk test with walk-test log and printout
- System alarm verification selection per detector point
- PAS (Positive Alarm Sequence) and Pre-signal per point (NFPA 72 compliant)
- Up to 16 ANN-BUS annunciators- 8 per each ANN-Bus
- Remote Acknowledge, Alarm Silence, Reset and Drill via addressable modules or remote annunciator
- Upload/Download of program and data via USB with optional FS-Tools Programming Utility

SLC COMMUNICATION LOOP

- Supports FlashScan® and CLIP protocols
- SLC operates up to 10,000 ft. (3,000 m) in FlashScan mode with twisted, unshielded wire
- Single addressable SLC loop which meets NFPA Class B and Class A requirements
- 198 addressable device capacity (99 addressable detectors and 99 modules)
- Compatible with NOTIFIER FireWarden and ONYX Series addressable devices (refer to the *FireWarden SLC Wiring Manual*)

NOTIFICATION APPLIANCE CIRCUITS (NACS)

- Four independently programmable output circuits. Circuits can be configured for the following outputs:
 - **Style Y** (Class B)
 - **Style Z** (Class A)
- Silence Inhibit and Autosilence timer options
- Continuous, March Time, Temporal, or California code for main circuit board NACs with two-stage capability
- Selectable strobe synchronization per NAC
- 2.5 A special application, 250mA regulated, total power for NACs

NOTE: Maximum or total 24VDC system power shared between all NAC circuits and the ANN-BUS is 2.7 A

PROGRAMMING AND SOFTWARE

- Autoprogramming (learn mode) reduces installation time
- Custom English labels (per point) may be manually entered or selected from an internal library file
- Two programmable Form-C relay outputs
- 99 software zones
- Continuous fire protection during online programming
- Program Check automatically catches common errors not linked to any zone or input point
- **OFFLINE PROGRAMMING:** Create the entire program in your office using FS-Tools, a Windows®-based software package, and upload/download system programming locally. Offline programming requires an ethernet connection. FS-Tools is available on www.notifier.com.

User interface

LED INDICATORS

- Fire Alarm (red)
- AC Power (green)
- Trouble (yellow)
- Battery fault (yellow)
- Maintenance (yellow)
- Alarm Silenced (yellow)
- CO Alarm (red)
- Supervisory (yellow)
- Ground fault (yellow)
- Disabled (yellow)
- Communication (yellow)
- F1-F4 Programmable Function Keys (yellow)

KEYPAD

- 16 key alpha-numeric pad
- Alarm Silence
- Four (4) programmable function keys
- Acknowledge
- Drill (Manual Evacuate)
- Reset (lamp test)

PRODUCT LINE INFORMATION

NFW-100X: Addressable Fire Alarm Control Panel with one SLC loop. Includes main circuit board with display chassis with transformer, backbox with door, plastic bag containing screws, cables, key, etc.

FS-Tools: Programming software for Windows®-based PC computer. Available for download at www.notifier.com.

CELL-CAB-N/CELL-MOD: Optional GSM communicators.

IPOTS-COM: Dual technology (POTS and IP) communicator. (replacement board)

DP-ES-R: Optional dress panel for the NFW-100X (red).

DP-ES-B: Optional dress panel for NFW-100X (black).

TR-CE-B: Optional trim ring for semi-flush mounting. (Black. For red, order **TR-CE**.)

BB-XP: Optional cabinet for one or two modules.

BB-25: Optional cabinet for up to six modules mounted on CHS-6 chassis.

BB-26: Battery backbox, holds up to two 25 AH batteries and CHG-75.

NFS-LBB: Battery box, houses two 55 AH batteries

CHS-6: Chassis, mounts up to six multi-modules in a BB-25 cabinet.

CHG-75: Battery charger for lead-acid batteries with a rating of 25 to 75 AH.

CHG-120: Remote battery charging system for lead-acid batteries with a rating of 55 to 120 AH. Requires additional NFS-LBB for mounting.

NOTE: CHG-120 or CHG-75 required for batteries larger than 18AH.

BAT Series: Batteries, see data sheet DN-6933.

PRN Series: UL listed compatible event printer. Uses tractor-fed paper.

OPTIONAL MODULES

4XTM Reverse Polarity Transmitter Module: Provides a super-

vised output for local energy municipal box transmitter, alarm and trouble. Includes a disable switch and disable trouble LED.

PWRMOD24 Power Expander Module: Optional power module. Increases alarm power output to 6 amps.

COMPATIBLE ANNUNCIATORS

N-ANN-80: Remote LCD annunciator mimics the information displayed on the FACP LCD display. Recommended wire type is unshielded. (Basic model is black; order -W for white; see DN-7114.)

N-ANN-100R: Remote LCD annunciator mimics the information displayed on the FACP LCD display. Recommended wire type is unshielded. For use in FM applications only. (Basic model is black; order R for red.)

N-ANN-I/O: LED Driver Module provides connections to a user supplied graphic annunciator. (See DN-7105.)

N-ANN-LED: Annunciator Module provides three LEDs for each zone: Alarm, Trouble, and Supervisory. Ships with red enclosure. (See DN-60242.)

N-ANN-RLED: Provides alarm (red) indicators for up to 30 input zones or addressable points. (See DN-60242.)

N-ANN-RLY: Relay Module provides 10 programmable Form-C relays. Can be mounted inside the cabinet. (See DN-7107.)

N-ANN-S/PG: Serial/Parallel Printer Gateway module provides a connection for a serial or parallel printer. (See DN-7103.)

ADDRESSABLE DEVICES

FSP-951: Addressable low-profile photoelectric smoke detector. FlashScan only.

FSP-951-IV: Addressable low-profile photoelectric smoke detector. Ivory. FlashScan and CLIP mode.

NP-200: Addressable low-profile photoelectric smoke detector. B300-6 base included, FlashScan only.

NP-200-IV: Addressable low-profile photoelectric smoke detector. Ivory, B300-6-IV base included. FlashScan and CLIP mode.

FSP-951T: Addressable low-profile photoelectric smoke detector with thermal sensor. FlashScan only.

FSP-951T-IV: Addressable low-profile photoelectric smoke detector with thermal sensor. Ivory. FlashScan and CLIP mode.

NP-200T: Addressable low-profile photoelectric smoke detector with thermal sensor. B300-6 base included. FlashScan only.

NP-200T-IV: Addressable low-profile photoelectric smoke detector with thermal sensor. Ivory, B300-6-IV base included. FlashScan and CLIP mode.

FSP-951R: Remote test capable addressable photoelectric smoke detector for use with DNR(W) duct detector housing. FlashScan only.

FSP-951R-IV: Remote test capable addressable photoelectric smoke detector for use with DNR(W) duct detector housing. Ivory. FlashScan and CLIP mode.

NP-200R: Remote test capable addressable photoelectric smoke detector for use with DNR(W) duct detector housing. FlashScan only.

NP-200R-IV: Remote test capable addressable photoelectric smoke detector for use with DNR(W) duct detector housing. Ivory, FlashScan and CLIP mode.

FST-951: Low-profile 135°F fixed thermal sensor. FlashScan only.

FST-951-IV: Low-profile 135°F fixed thermal sensor. Ivory. FlashScan and CLIP mode.

NH-200: Low-profile 135°F fixed thermal sensor. B300-6 base included, FlashScan only.

NH-200-IV: Low-profile 135°F fixed thermal sensor. Ivory. B300-6-IV base included, FlashScan and CLIP mode.

FST-951R: Low-profile, intelligent, rate-of-rise thermal sensor. FlashScan only.

FST-951R-IV: Low-profile, intelligent, rate-of-rise thermal sensor. Ivory. FlashScan and CLIP mode.



NH-200R: Low-profile 135°F fixed thermal sensor. B300-6 base included, FlashScan only.

NH-200R-IV: Low-profile 135°F fixed thermal sensor. Ivory. B300-6-IV base included, FlashScan and CLIP mode.

FST-951H: Low-profile intelligent 190°F/88°C fixed thermal sensor. FlashScan only.

FST-951H-IV: Low-profile intelligent 190°F/88°C fixed thermal sensor. Ivory. FlashScan and CLIP mode.

NH-200H: Low-profile intelligent 190°F/88°C fixed thermal sensor. B300-6 base included, FlashScan only.

NH-200H-IV: Low-profile intelligent 190°F/88°C fixed thermal sensor. Ivory. B300-6-IV base included, FlashScan and CLIP mode.

Legacy Devices

FSI-851: Addressable low-profile ionization smoke detector.

NI-100: Addressable low-profile ionization smoke detector.

FSP-851: Addressable low-profile photoelectric smoke detector.

NP-100: Addressable low-profile photoelectric smoke detector.

FSP-851T: Addressable low-profile photoelectric smoke detector with thermal sensor.

NP-100T: Addressable low-profile photoelectric smoke detector with thermal sensor.

FSP-851R: Remote test capable addressable photoelectric smoke detector for use with DNR(W) duct detector housing.

NP-100R: Remote test capable addressable photoelectric smoke detector for use with DNR(W) duct detector housing.

FST-851: Fast-response, low-profile heat detector.

NH-100: Fast-response, low-profile heat detector.

FST-851R: Fast-response, low-profile heat detector with rate-of-rise option.

NH-100R: Fast-response, low-profile heat detector with rate-of-rise option.

FST-851H: Fast-response, low-profile heat detector that activates at 190°F/88°C.

NH-100H: Fast-response, low-profile heat detector that activates at 190°F/88°C.

FAPT-851: Addressable low-profile multi-sensor detector.

NP-A100: Addressable low-profile multi-sensor detector.

B200SR: Addressable sounder base.

DNR: InnovairFlex low-flow non-relay duct-detector housing. (Order FSP-851R, FSP-951R, or NP-100R separately.)

DNRW: InnovairFlex low-flow non-relay duct-detector housing, with NEMA-4 rating. Watertight. (Order FSP-851R, FSP-951R, or NP-100R separately.)

Addressable Modules

FMM-1: Addressable Monitor Module for one zone of normally-open dry-contact initiating devices. Mounts in standard 4.0" (10.16 cm.) box. Includes plastic cover plate and end-of-line resistor. Module may be configured for either a Style B (Class B) or Style D (Class A) IDC.

NMM-100: Addressable Monitor Module for one zone of normally-open dry-contact initiating devices. Mounts in standard 4.0" (10.16 cm.) box. Includes plastic cover plate and end-of-line resistor. Module may be configured for either a Style B (Class B) or Style D (Class A) IDC.

FDM-1: Dual Monitor Module. Same as NMM-100 except it provides two Style B (Class B) only IDCs.

NDM-100: Dual Monitor Module. Same as NMM-100 except it provides two Style B (Class B) only IDCs.

FMM-101: Miniature version of NMM-100. Excludes LED and Style D option. Connects with wire pigtailed. May mount in device backbox.

NMM-100P: Miniature version of NMM-100. Excludes LED and Style D option. Connects with wire pigtailed. May mount in device backbox.

FZM-1: Similar to NMM-100. Addressable Monitor Module for one

zone of conventional two-wire detectors. Requires resettable 24 VDC power. Refer to the *Device Compatibility Document* for listed compatible devices and quantity limitation.

NZM-100: Similar to NMM-100. Addressable Monitor Module for one zone of conventional two-wire detectors. Requires resettable 24 VDC power. Refer to the *Device Compatibility Document* for listed compatible devices and quantity limitation.

FCM-1: Addressable Control Module for one Style Y/Z (Class B/A) zone of supervised polarized Notification Appliances. Mounts directly to a 4.0" (10.16 cm.) electrical box. NAC option requires external 24 VDC to power notification appliances.

NC-100: Addressable Control Module for one Style Y/Z (Class B/A) zone of supervised polarized Notification Appliances. Mounts directly to a 4.0" (10.16 cm.) electrical box. NAC option requires external 24 VDC to power notification appliances.

FRM-1: Addressable relay module containing two isolated sets of Form-C contacts, which operate as a DPDT switch. Mounts directly to a 4.0" (10.16 cm.) box, surface mount using the SMB500.

NC-100R: Addressable relay module containing two isolated sets of Form-C contacts, which operate as a DPDT switch. Mounts directly to a 4.0" (10.16 cm.) box, surface mount using the SMB500.

NBG-12LX: Addressable manual pull station with interface module mounted inside.

NOT-BG12LX: Addressable manual pull station with interface module mounted inside.

ISO-X: Fault Isolator Module.

N100-ISO: Fault Isolator Module.

ISO-6: Six-fault isolator module. Mount one or two modules in a BB-XP cabinet (optional). Mount up to six modules on a CHS-6 chassis in a CAB-3/CAB-4 series cabinet.

SMB500: Used to mount all modules except the FMM-101/NMM-100P.

NMM-100-10: Ten-input monitor module. Mount one or two modules in a BB-2F cabinet (optional). Mount up to six modules on a CHS-6 chassis in a BB-6F cabinet.

NZM-100-6: Six-zone interface module. Mount one or two modules in a BB-XP cabinet (optional). Mount up to six modules on a CHS-6 chassis in a CAB-3/CAB-4 series cabinet.

SWIFT Wireless Devices

FWSG: Wireless Gateway

FWD-200P: intelligent, wireless photo detector.

FWH-200ROR135: LiteSpeed intelligent wireless rate of rise (135°) heat detector.

FWD-200ACCLIMATE: Wireless Acclimate Detector

FWH-200FIX135: intelligent wireless fixed-temperature (135°) heat detector.

FW-MM: Intelligent wireless monitor module.

FW-RM: Intelligent wireless relay module.

NBG-12LW: Intelligent wireless pull station.

WAV-RL, WAV-WL, WAV-CRL, WAV-CWL: Intelligent AV bases.

W-USB: Wireless USB radio/antenna dongle that plugs into the USB port of a PC running SWIFT Tools.

SWIFT Tools: Programming and diagnostic utility for the Wireless Gateway and devices. Available for download from firelite.com.

NOTE: For more information on Compatible Addressable Devices for use with the FireWarden-100X, see the following data sheets (document numbers): NP-200 Series (DN-60979), NH-200 Series (DN-60980), FSP-851 Series (DN-6935), FSP-951 Series (DN-60977), FST-851 Series (DN-6936), FST-951 Series (DN-60975), FAPT-851 (DN-6937), N100-ISO (DN-6994), NP-100 series (DN-6995), NH-100/NH-100R (DN-6997), DNR/InnovairFlex (DN-60424, DN-60429), NP-A100 (DN-6998), NMM-100/NMM-100P/NDM-100/NZM-100 (DN-6999), NC-100 (DN-7000), NC-100R (DN-60383), NMM-100-10 (DN-6990), MM-1/FDM-1/FZM-1/FMM-101 (DN-6720), FCM-1/FRM-1 (DN-6724), NOT-BG12LX (DN-7001), NBG-12LX (DN-6726), and FireWarden SLC Manual (52304).



System Capacity

- Intelligent Signaling Line Circuits..... 1
- Addressable device capacity 198
- Programmable software zones 99
- Annunciators..... 16

Electrical Specifications

AC Power: 120/240 VAC, 50/60 Hz, 3.25 A. Wire size: minimum 14 AWG (2.00 mm²) with 600 V insulation. Nonpower-limited, supervised.

Battery: Two 12 V 18 AH lead-acid batteries. Battery Charger Capacity: 7-18 AH (FireWarden-100X cabinet holds maximum of two 18 AH batteries.)

Communication Loop: Supervised and power-limited.

Notification Appliance Circuits: Terminal Block provides connections for four NACs, Style Y (Class B) or Style Z (Class A). Special Application power. Power-limited, supervised circuitry. Maximum signaling current per circuit: 2.5 amps special application, 250mA regulated. End-of-Line Resistor: 4.7k ohm, ½ watt (P/N 71252 UL listed) for Style Y (Class B) NAC; system capable of 1.9 kΩ - 22 kΩ ELR range. Refer to the *NOTIFIER Device Compatibility Document* for listed compatible devices.

Two Programmable Relays and One Fixed Trouble Relay: Contact rating: 2.0 A @ 30 VDC (resistive), 0.5 A @ 30 VAC (resistive). Form-C relays, non-power-limited, non-supervised.

Cabinet Specifications

Door: 19.26" (48.92 cm.) high x 16.82" (42.73 cm.) wide x 0.72" (1.82 cm.) deep. **Backbox:** 19.00" (48.26 cm.) high x 16.65" (42.29 cm.) wide x 5.25" (13.34 cm.) deep. **Trim Ring (TR-CE/B):** 22.00" (55.88 cm.) high x 19.65" (49.91 cm.) wide.

Shipping Specifications

Weight: 26.9 lbs. (12.20 kg.) **Dimensions:** 20.00" (50.80 cm.) high x 22.5" (57.15 cm.) wide x 8.5" (21.59 cm.) deep.

Temperature and Humidity Ranges

This system meets NFPA requirements for operation at 0 – 49°C/32 – 120°F and at a relative humidity 93% ± 2% RH (noncondensing) at 32°C ± 2°C (90°F ± 3°F). However, the useful life of the system's standby batteries and the electronic components may be adversely affected by extreme temperature ranges and humidity. Therefore, it is recommended that this system and its peripherals be installed in an environment with a normal room temperature of 15 – 27°C/60 – 80°F.

Addressable Device Accessories

End-of-Line Resistor Assembly (R-47K and R-3.9K): The 47k ohm assembly supervises the NMM-100-10, NDM-100, NMM-100P, and NC-100 module circuits. The 3.9k ohm assembly supervises the NZM-100-6 module circuit. These resistors are included with each module.

Power Supervision Relay: Supervises the power to 4-wire smoke detectors and notification appliances.

Wiring Requirements

While shielded wire is not required, it is recommended that all SLC wiring be twisted-pair to minimize the effects of electrical interference. Refer to the panel manual for wiring details.

NFPA Standards

The FireWarden-100X complies with the following NFPA 72 Fire Alarm Systems requirements:

- **LOCAL** (Automatic, Manual, Waterflow and Sprinkler Supervisory).
- **AUXILIARY** (Automatic, Manual and Waterflow) (requires 4XTM).
- **REMOTE STATION** (Automatic, Manual and Waterflow) (Where a DACT is not accepted, the alarm, trouble and supervisory relays may be connected to UL 864 listed transmitters. For reverse polarity signaling of alarm and trouble, 4XTM is required.)
- **PROPRIETARY** (Automatic, Manual and Waterflow).
- **CENTRAL STATION** (Automatic, Manual and Waterflow, and Sprinkler Supervised).
- **OT, PSDN** (Other Technologies, Packet-switched Data Network)
- **IBC 2012, IBC 2009, IBC 2006, IBC 2003, IBC 2000** (Seismic).
- **CBC 2007** (Seismic)

Agency Listings and Approvals

The listings and approvals below apply to the basic FireWarden-100X control panel. In some cases, certain modules may not be listed by certain approval agencies, or listing may be in process. Consult factory for latest listing status.

- **UL:** S635
- **CSFM:** 7165-0028:0505

NOTIFIER

12 Clintonville Road
Northford, CT 06472
203.484.7161
www.notifier.com



This document is not intended to be used for installation purposes.
We try to keep our product information up-to-date and accurate.
We cannot cover all specific applications or anticipate all requirements.
All specifications are subject to change without notice.

AlarmNet®, NOTIFIER®, FireWarden®, SWIFT®, and System Sensor® are registered trademarks of Honeywell International Inc. Microsoft® and Windows® are registered trademarks of the Microsoft Corporation.

©2018 by Honeywell International Inc. All rights reserved. Unauthorized use of this document is strictly prohibited.

Country of Origin: USA



Reviewed for Code Compliance
Permitting and Inspections
Department
Approved 02/10/2020



BAT Series Batteries

Sealed Lead-Acid or Gell Cell



Power Supplies

General

BAT Series Batteries feature a new part-numbering/listing system — providing an improved method of delivery for NOTIFIER-approved sealed lead-acid batteries for all your fire alarm system needs. Multiple brands of batteries are now offered under generic part numbers, reducing backorder situations and permitting us to deliver these products in a more timely fashion. NOTIFIER has approved the multiple brands listed below as possible product shipped for a given part number. Please note that any incoming orders for “PS Series” batteries will be converted to the equivalent BAT Series part numbers.



6933cov.jpg

Features

- Provide secondary power for control panels.
- Sealed and maintenance-free.
- Overcharge protected.
- Easy handling with leakproof construction.
- Ruggedly constructed, high-impact case (ABS, polystyrene, or polypropylene, depending on models).
- Long service life.
- Compact design.

Agency Listings and Approvals

The listings and approvals below apply to BAT Series Batteries. In some cases, certain modules may not be listed by certain approval agencies, or listing may be in process. Consult factory for latest listing status.

- **UL Recognized Components:** files MH19884 (*B & B Battery*), MH20567 (*UPG, previously Jolt*), MH20845 (*Power-Sonic*).

Part Number Reference

CURRENT Part Number	BATTERY DESCRIPTION	ALTERNATES APPROVED: manufacturers and P/Ns shipped under BAT P/Ns
BAT-1250	12 V, 5 AH, sealed.	BP5-12 (B&B Battery); PS-1250 (Power-Sonic); SA1250 (Jolt) to be replaced with UB1250 (UPG).
BAT-1250	12 V, 5 AH, sealed.	BP5-12 (B&B Battery); PS-1250 (Power-Sonic); SA1250 (Jolt) to be replaced with UB1250 (UPG).
BAT-1270	12 V, 7 AH, sealed.	BP7-12 (B&B Battery); PS-1270 (Power-Sonic); SA1272 (Jolt) to be replaced with UB1270 (UPG).
BAT-12120	12 V, 12 AH, sealed.	BP12-12 (B&B Battery); PS-12120 (Power-Sonic); SA12120 (Jolt) to be replaced with UB12120 (UPG).
BAT-12180	12 V, 18 AH, sealed.	PS-12180 (Power-Sonic); SA12180 (Jolt) to be replaced with UB12180 (UPG).
BAT-12180	12 V, 18 AH, sealed.	PS-12180 (Power-Sonic); SA12180 (Jolt) to be replaced with UB12180 (UPG).
BAT-12260	12 V, 26 AH, sealed.	BP26-12 (B&B Battery); PS-12260 (Power-Sonic); SA12260 (Jolt) to be replaced with UB12260 (UPG).
BAT-12550	12 V, 55 AH, sealed.	PS-12550 (Power-Sonic); XSA12550 (Jolt) to be replaced with UB12550 (UPG).
BAT-12550	12 V, 55 AH, sealed.	PS-12550 (Power-Sonic); XSA12550 (Jolt) to be replaced with UB12550 (UPG).
BAT-121000	12 V, 100 AH, gell cell.	PS-121000 (Power-Sonic); XSA121000A (Jolt) to be replaced with UB121000 (UPG).



Reviewed for Code Compliance
Permitting and Inspections
Department
Approved 02/10/2020



POWER-SONIC

Part Number Reference

MODEL	Nominal Voltage V	Nominal Capacity @ 20 hr. rate A.H.	Discharge Current @20 hr. rate mA	DIMENSIONS									
				Width		Depth		Height		Height over terminal		Weight	
				in.	mm	in.	mm	in.	mm	in.	mm	lb.	kg.
PS-1250	12	5	250	3.54	90	2.76	70	4.02	102	4.21	107	4.1	1.9
PS-1270	12	7	325	5.94	151	2.56	65	3.7	94	3.86	98	5.7	2.6
PS-12120	12	12	600	5.94	151	3.86	98	3.7	94	3.86	98	8.8	4
PS-12180	12	18	875	7.13	181	2.99	76	6.57	167	6.57	167	12.8	5.8
PS-12250	12	25	1300	6.89	175	6.54	166	4.92	125	4.92	125	18.7	8.5
PS-12550	12	55	3000	10.25	260	6.6	168	8.2	208	9.45	240	39.7	18
PS-121000	12	100	5000	12	305	6.6	168	8.2	208	9.45	240	65.7	29.8

Characteristic Discharge Curves

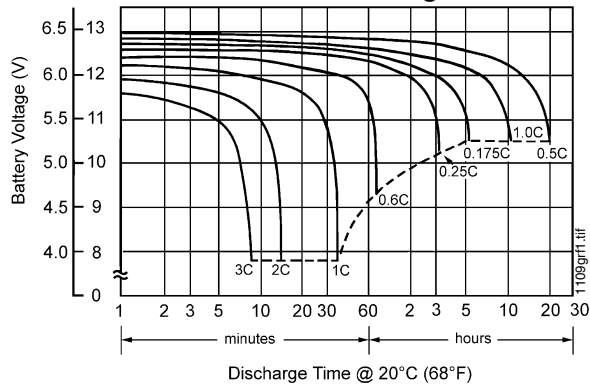

Effect of Temperature on Capacity

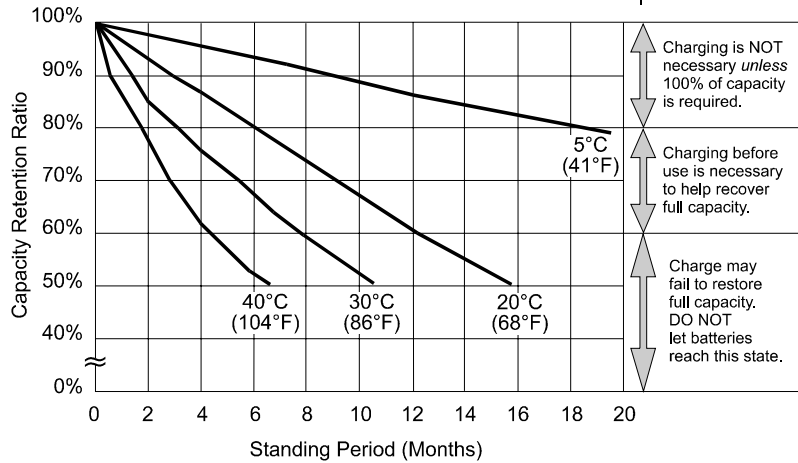
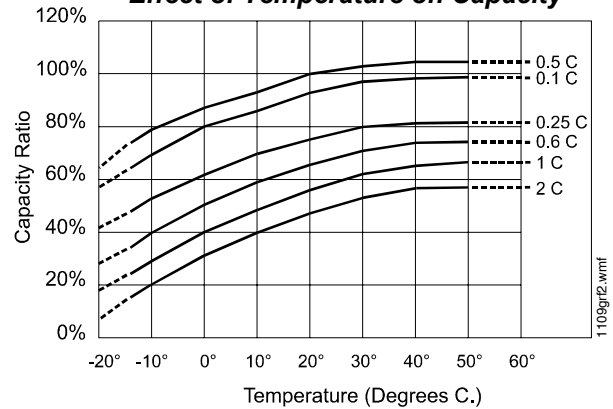

**at left:
PS-121000
Shelf-Life
and Storage**

Charging is NOT necessary unless 100% of capacity is required.
Charging before use is necessary to help recover full capacity.
Charge may fail to restore full capacity. DO NOT let batteries reach this state.

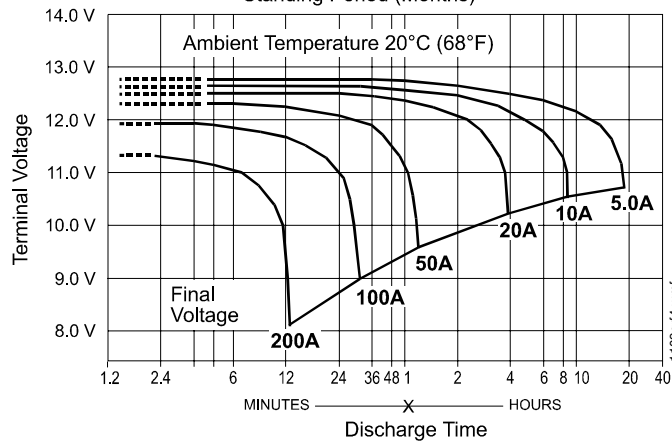

**at left:
PS-121000
Discharge
Characteristics**

NOT-BG12LX

Addressable Manual Pull Station



Intelligent/Addressable Devices

General

The Notifier NOT-BG12LX is a state-of-the-art, dual-action (i.e., requires two motions to activate the station) pull station that includes an addressable interface for FireWarden series intelligent control panels, and the NSP-25 panel. Because the NOT-BG12LX is addressable, the control panel can display the exact location of the activated manual station. This leads fire personnel quickly to the location of the alarm.

Features

- Maintenance personnel can open station for inspection and address setting without causing an alarm condition.
- Built-in bicolor LED, which is visible through the handle of the station, flashes in normal operation and latches steady red when in alarm.
- Handle latches in down position and the word “ACTIVATED” appears to clearly indicate the station has been operated.
- Captive screw terminals wire-ready for easy connection to SLC loop (accepts up to 12 AWG/3.25 mm² wire).
- Can be surface mounted (with SB-10 or SB-I/O) or semi-flush mounted. Semi-flush mount to a standard single-gang, double-gang, or 4" (10.16 cm) square electrical box.
- Smooth dual-action design.
- Meets ADAAG controls and operating mechanisms guidelines (Section 4.1.3[13]); meets ADA requirement for 5 lb. maximum activation force.
- Highly visible.
- Attractive shape and textured finish.
- Key reset.
- Includes Braille text on station handle.
- Optional trim ring (BG12TR).
- Meets UL 38, Standard for Manually Actuated Signaling Boxes.

Construction

Shell, door, and handle are molded of durable polycarbonate material with a textured finish.

Specifications

- **Shipping Weight:** 9.6 oz. (272.15 g)
- **Normal operating voltage:** 24 VDC.
- **Maximum SLC loop voltage:** 28.0 VDC.
- **Maximum SLC standby current:** 375 μ A.
- **Maximum SLC alarm current:** 5 mA.
- **Temperature Range:** 32°F to 120°F (0°C to 49°C)
- **Relative Humidity:** 10% to 93% (noncondensing)
- **For use indoors in a dry location**

Installation

The NOT-BG12LX will mount semi-flush into a single-gang, double-gang, or standard 4" (10.16 cm) square electrical outlet box, or will surface mount to the model SB-10 or SB-I/O surface backbox. If the NOT-BG12LX is being semi-flush mounted, then the optional trim ring (BG12TR) may be used.



**The NOT-BG12LX
Addressable Manual Pull Station**

The BG12TR is usually needed for semi-flush mounting with 4" (10.16 cm) or double-gang boxes (not with single-gang boxes).

Operation

Pushing in, then pulling down on the handle causes it to latch in the down/activated position. Once latched, the word “ACTIVATED” (in bright yellow) appears at the top of the handle, while a portion of the handle protrudes from the bottom of the station. To reset the station, simply unlock the station with the key and pull the door open. This action resets the handle; closing the door automatically resets the switch.

Each manual station, on command from the control panel, sends data to the panel representing the state of the manual switch. Two rotary decimal switches allow address settings (1 – 99 on NFW2-100/NFW2-100C, 1 – 50 for NFW-50/NFW-50C).

Architectural/Engineering Specifications

Manual Fire Alarm Stations shall be non-coded, with a key-operated reset lock in order that they may be tested, and so designed that after actual Emergency Operation, they cannot be restored to normal except by use of a key. An operated station shall automatically condition itself so as to be visually detected as activated. Manual stations shall be constructed of red-colored polycarbonate material with clearly visible operating instructions provided on the cover. The word FIRE shall appear on the front of the stations in white letters, 1.00 inches (2.54 cm) or larger. Stations shall be suitable for surface mounting on matching backbox SB-10 or SB-I/O; or semi-flush mounting on a standard single-gang, double-gang, or 4" (10.16 cm) square electrical box, and shall be installed



Reviewed for Code Compliance
Permitting and Inspections
Department
Approved by: [Signature]
02/10/2020



within the limits defined by the Americans with Disabilities Act (ADA) or per national/local requirements. Manual Stations shall be Underwriters Laboratories listed.

Manual stations shall connect with two wires to one of the control panel SLC loops. The manual station shall, on command from the control panel, send data to the panel representing the state of the manual switch. Manual stations shall provide address setting by use of rotary decimal switches.

Product Line Information

NOT-BG12LX: Dual-action addressable pull station. Includes key locking feature. (Listed for Canadian and non-Canadian applications.)

SB-10: Surface backbox; metal.

SB-I/O: Surface backbox; plastic.

BG12TR: Optional trim ring.

17021: Keys, set of two.

Agency Listings and Approvals

In some cases, certain modules or applications may not be listed by certain approval agencies, or listing may be in process. Consult factory for latest listing status.

- **UL/ULC Listed:** S692 (listed for Canadian and non-Canadian applications).
- **MEA:** 67-02-E Vol. IV.
- **CSFM:** 7150-0028:0199.
- **FM Approved.**

Patented: U.S. Patent No. D428,351; 6,380,846; 6,314,772; 6,632,108.

NOTIFIER® is a registered trademark of Honeywell International Inc.
©2012 by Honeywell International Inc. All rights reserved. Unauthorized use of this document is strictly prohibited.



This document is not intended to be used for installation purposes.
We try to keep our product information up-to-date and accurate.
We cannot cover all specific applications or anticipate all requirements.
All specifications are subject to change without notice.



Made in the U.S. A.

For more information, contact Notifier. Phone: (203) 484-7161, FAX: (203) 484-7118.
www.notifier.com



CO1224T and CO1224TR Carbon Monoxide Detectors with RealTest® Technology

The System Sensor CO1224T and CO1224TR (round) Carbon Monoxide (CO) Detectors use a highly accurate and reliable electrochemical sensing cell to provide early warning of dangerous CO levels.

Features

- RealTest® enables a functional test using canned CO
- Full compliance with UL 2075
- A code-required trouble relay
- Wiring supervision with SEMS terminals
- A six-year end-of-life timer
- 12/24 VDC
- A low current draw of 20 mA in standby and 40 mA in alarm
- Versatile mounting for wall and ceiling
- Accurate and reliable electrochemical sensing technology
- Optional CO-PLATE CO Detector Replacement Plate to upgrade previously installed competitor detectors to the CO1224T



With RealTest® technology, the CO gas sensing cell used in the CO1224T and CO1224TR CO detectors can be tested using a CO gas agent, fully meeting the requirements of NFPA 720: 2009. Simply put the detector into RealTest mode, spray a small amount of CO into the detector per the installation instructions, and within seconds the detector will alarm, indicating successful gas entry. (See the reverse page or the user manual for complete instructions.)

When dangerous amounts of CO are detected, the CO1224T and CO1224TR detectors alert residents by sounding and flashing a temp 4 signal alarm. With 24/7 central station monitoring, residents are guaranteed protection whether they are away from home, sleeping, or already suffering from the effects of CO.

The CO1224T and CO1224TR are designed for system operation. These detectors are fully listed to UL 2075 and offer a code-required trouble relay to send a sensor failure or end-of-life signal to the control panel and the central station. The CO1224T and CO1224TR also use SEMS-type terminal Philips head screws for quicker and more positive wiring connections and code-required wiring supervision. With a low current draw, these detectors enable more devices to be connected to the panel, limiting the need to purchase extra power supplies or more expensive panels. As 12/24 VDC detectors, the CO1224T and CO1224TR will operate on most industry security and fire alarm control panels.

Agency Listings





CO1224T and CO1224TR Carbon Monoxide Detector Specifications

Architectural/Engineering Specifications

Carbon monoxide (CO) detector shall be a system-connected System Sensor model number CO1224T or CO1224TR listed to Underwriters Laboratories UL 2075 for Gas and Vapor Detectors and Sensors. The detector shall be equipped with a sounder and a trouble relay. The detector's base shall be able to mount to a single-gang electrical box or direct (surface) mount to the wall or ceiling. Wiring connections shall be made by means of SEMS screws. The detector shall provide dual-color LED indication that blinks to indicate normal standby, alarm, or end-of-life. When the sensor supervision is in a trouble condition, the detector shall send a trouble signal to the panel. When the detector gives a trouble or end-of-life signal, the detector shall be replaced. The detector shall provide a means to test CO gas entry into the CO sensing cell. The detector shall provide this with a test mode that accepts CO gas from a test agent and alarms immediately upon sensing CO entry. The detector shall perform in the detection of CO up to 12,000 feet above sea level and alarm within the time specified by ANSI/UL 2034 for CO concentrations of 70, 150 and 400 parts per million (ppm), as verified by a Nationally Recognized Test Laboratory.

Electrical Specifications

Operating Voltage	12/24 VDC
Audible Signal	85 dB in alarm
Standby Current	20 mA
Alarm Current	40 mA (75 mA test)
Alarm Contact Ratings	0.5 A @ 30 VDC
Trouble Contact Ratings	0.5 A @ 30 VDC

Physical Specifications

Size: CO1224T	Length: 5.1 in, Width: 3.3 in, Height: 1.3 in
CO1224TR	Diameter: 6 in, Height: 1.3 in
Approximate Weight	CO1224T: 7 oz ; CO1224TR: 11 oz
Operating Temperature Range	32°F to 104° F (0°C to 40° C)
Operating Humidity Range	22 to 90% RH
Input Terminals	14 to 22 AWG
Mounting	Single-gang back box; surface mount to wall or ceiling

Operation Modes

Operation Mode	Green LED	Red LED	Sounder
Normal (standby)	Blink 1 per minute	—	—
Alarm	—	Blink in temp 4 pattern	Sound in temp 4 pattern

RealTest® Feature: The System Sensor CO1224T and CO1224TR Carbon Monoxide Detectors with RealTest enable evaluation of the functionality of the CO sensing cell using a canned CO test agent.



1. Push and hold the Test/Hush button for two seconds to enter RealTest mode. The green LED will flash once every second to indicate RealTest mode has started.



2. Spray canned CO agent into the detector.

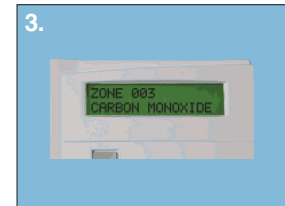

3. Verify CO sensing at the control panel. The detector will automatically exit RealTest alarm mode after about 20-60 seconds.

NOTE: Check with local codes and the AHJ to determine if a functional gas test is desired for an installation.

Hush Feature: Pushing the Test/Hush button will silence the sounder for 5 minutes (except in RealTest mode).
 Trouble Feature: When the detector is in a trouble condition, it will send a trouble signal to the panel.
 End-of-Life Timer: After the detector's internal sensor has reached the end of its life, a trouble signal will be sent to the panel to indicate it is time to replace the detector. An electrochemical CO detector lifespan is about six years. The detector must be replaced by the date marked on the inside of the product.
 CO-PLATE: System Sensor also offers the CO-PLATE CO Detector Replacement Plate to cover the footprint (when necessary) of previously installed competitive carbon monoxide detectors that require replacement.



CO-PLATE

Ordering Information

Part No.	Description
CO1224T	12/24 volt, 4-wire system-monitored carbon monoxide detector with RealTest® Technology
CO1224TR	12/24 volt, 4-wire system-monitored round carbon monoxide detector with RealTest® Technology
CO-PLATE	CO detector replacement plate to cover the footprint of previously installed competitive detectors as necessary



3825 Ohio Avenue • St. Charles, IL 60174
 Phone: 800-SENSOR2 • Fax: 630-377-6495
www.systemsensor.com

©2012 System Sensor.
 Product specifications subject to change without notice. Visit systemsensor.com
 for current product information, including the latest version of this data sheet.
 Cods72701 • 4/12

NP-200 Series

Addressable Photoelectric Detectors



Addressable Devices

General

The NOTIFIER NP-200 Series intelligent plug-in smoke detectors are designed for both performance and aesthetics. A new modern, sleek, contemporary design and enhanced optical sensing chamber is engineered to sense smoke produced by a wide range of combustion sources in accordance with more stringent code standards. Exclusively for use with NOTIFIER's FireWarden Series Addressable Fire Alarm Control Panels, the NP-200 Series point ID capability allows each detector's address to be set with rotary, decimal address switches, providing exact detector location for emergency personnel quickly locate a fire during its early stages, potentially saving precious rescue time while also reducing property damage. Two LEDs on each sensor light to provide a local, visible sensor indication. Dual electronic thermistors add 135°F (57°C) fixed temperature thermal sensing on the NP-200T. The NP-200R is a remote test capable detector for use with DNR Series duct detector housings.

Features

SLC LOOP

- Two-wire loop connection.
- Unit uses base for wiring.

ADDRESSING

- Addressable by device.
- Rotary, decimal addressing: *Please refer to the FireWarden panel manuals for device capacity.*

ARCHITECTURE

- New modern profile for improved aesthetics.
- Unique single-source design to respond quickly and dependably to a broad range of fires.
- Integral communications and built-in type identification.
- Built-in tamper-resistant feature.
- Removable cover and insect-resistant screen for simple field cleaning.

OPERATION

- Designed to meet UL 268 7th Edition.
- Factory preset at 1.5% nominal sensitivity for panel alarm threshold level.
- Visible LED "blinks" when the unit is addressed (communicating with the fire panel) and latches on in alarm.
- Low standby current.

MECHANICALS

- Sealed against back pressure.
- Mounts to: single-gang box, 3.5" (8.89 cm) or 4.0" (10.16 cm) octagonal box, or 4.0" (10.16 cm) square electrical box (*with or without a mud ring - not included*).

OPTIONS

- Remote LED output connection, RA100Z.

Installation

NP-200 series plug-in detectors use a detachable mounting base to simplify installation, service and maintenance.



NP-200 in B300-6 Base



Reviewed for Code Compliance
Permitting and Inspections
Department
Approved 02/10/2020

Mount base (all base types) on an electrical backbox which is at least 1.5" (3.81 cm) deep. For a chart of compatible junction boxes, see *DN-60054*.

NOTE: *Because of the inherent supervision provided by the SLC loop, end-of-line resistors are not required. Wiring "T-taps" or branches are permitted for Style 4 (Class B) wiring. NP-200R mounts in a DNR/DNRW duct detector housing.*

Operation

Each NP-200 Series detector uses one possible addresses on the FireWarden Signaling Line Circuit (SLC). It responds to regular polls from the system and reports its type and status.

Detector Sensitivity Test

Each detector can have its sensitivity tested (required per NFPA 72, Chapter 14 on *Inspection, Testing and Maintenance*) when installed/connected to an FireWarden Series addressable fire alarm control panel. The results of the sensitivity test can be printed off the FireWarden Series for record keeping.

Specification

Voltage range: 15 – 32 VDC (peak).

Standby current: 200 µA @ 24 VDC.

Max current: 4.5 mA @ 24 VDC (latched "ON").

Air velocity: 4,000 ft./min. (20 m/sec.) maximum.

Sensitivity: UL Applications: 0.5% to 4.0% per foot obscuration

Size: 2.0" (5.3 cm) high; base determines diameter.

– B300-6: 6.1" (15.6 cm) diameter.

– B501: 4" (10.2 cm) diameter.

For a complete list of detector bases see *DN-60981*.

Shipping weight: 3.4 oz. (95 g).

Operating temperature range:

- NP-200: 0°C to 50°C (32°F to 122°F);
- NP-200T: 0°C to 38°C (32°F to 100°F).
- NP-200R: installed in a DNR(A)/DNRW -20°C to 70°C (-4°F to 158°F).

Relative humidity: 10%-93%, non-condensing.

Listings

Listings and approvals below apply to the NP200 Series detectors. In some cases, certain detectors may not be listed by certain approval agencies, or listing may be in process. Consult factory for latest listing status.

- UL/ULC Listed: S911
- CSFM: 7272-0028:0503
- FM Approved

Product Line Information

NOTE: Detectors must be mounted to one of the Intelligent Bases listed below.

NOTE: "IV" suffix indicates FlashScan® and CLIP device.

NP-200: White, Addressable photoelectric detector; B300-6 base included. FlashScan only.

NP-200-IV: Ivory, Addressable photoelectric detector; B300-6 base included.

NP-200T: White, Same as NP-200 but with thermal element; B300-6 base included. FlashScan only.

NP-200T-IV: Ivory, Same as NP-200 but with thermal element; B300-6 base included.

NP-200R: White, Remote test capable addressable photoelectric detector for use with DNR(A)/DNRW. FlashScan only.

NP-200R-IV: Ivory, Remote test capable addressable photoelectric detector; for use with DNR(A)/DNRW.

INTELLIGENT BASES

NOTE: For details on intelligent bases, see DN-60981.

B300-6: White, 6" base, standard flanged low-profile mounting base. (CSFM: 7300-1653:0109 Pending)

B300-6-IS: White, 6" base isolator. (CSFM: 7300-1653:0109 Pending)

B300-6-IV: Ivory, 6" base, standard flanged low-profile mounting base. (CSFM: 7300-1653:0109 Pending)

B300A-6: Same as B300-6, ULC listed.

B300A-6-IV: Ivory, 6" standard flanged low-profile mounting base, ULC listed.

B300-6-BP: Bulk pack of B300-6, package contains 10

B501-WHITE: White, 4" standard European flangeless mounting base. UL/ULC listed. (CSFM: 7300-1653:0109 Pending)

B501-BL: Black, 4" standard European flangeless mounting base. UL/ULC listed. (CSFM: 7300-1653:0109 Pending)

B501-IV: Ivory color, 4" standard European flangeless mounting base. UL/ULC listed. (CSFM: 7300-1653:0109 Pending)

B501BP: Bulk pack of B501-WHITE contains 10.

B224RB-WH: White, relay base. (CSFM: 7300-1653:0216 Pending)

B224RB-IV: Ivory, relay base. (CSFM: 7300-1653:0216 Pending)

B224RBA-WH: White, relay base, ULC listing.

B224RBA-IV: Ivory, relay base, ULC listing.

B224BI-WH: White, **isolator** detector base. (CSFM: 7300-1653:0216 Pending)

B224BI-IV: Ivory **isolator** detector base. (CSFM: 7300-1653:0216 Pending)

B224BIA-WH: White, **isolator** detector base, ULC listing.

B224BIA-IV: Ivory **isolator** detector base, ULC listing.

B200S-WH: White, Intelligent addressable sounder base capable of producing sound output in high or low volume with ANSI Temporal 3, ANSI Temporal 4, continuous tone, marching tone, and custom tone. Uses FlashScan protocol. (CSFM: 7300-1653:0213 Pending)

B200S-IV: Ivory, Intelligent addressable sounder base capable of producing sound output in high or low volume with ANSI Temporal 3, ANSI Temporal 4, continuous tone, marching tone, and custom tone. Uses FlashScan protocol. (CSFM: 7300-1653:0213 Pending)

B200SA-WH: Same as B200S-WH, ULC listing.

B200SA-IV: Same as B200S-IV, ULC listing.

B200SCOA-WH: White, Intelligent, programmable sounder base in English/French (required in Canada for ULC applications with SO Series detector applications).

B200SCOA-IV: Ivory Intelligent, programmable sounder base in English/French (required in Canada for ULC applications with SO Series detector applications, ULC listing).

B200S-LF-WH: White, Low Frequency Intelligent, programmable sounder base. Produces a fundamental frequency of 520 Hz +/- 10% with a square wave or its equivalent; designed to meet the NFPA 72 sleeping space requirement. (CSFM: 7300-1653:0238 Pending)

B200S-LF-IV: Ivory, Low Frequency Intelligent, programmable sounder base. Produces a fundamental frequency of 520 Hz +/- 10% with a square wave or its equivalent; designed to meet the NFPA 72 sleeping space requirement. (CSFM: 7300-1653:0238 Pending)

B200SR-WH: White, Intelligent sounder base capable of producing sound output with ANSI Temporal 3 or continuous tone. Intended for retrofit applications. (CSFM: 7300-1653:0213 Pending)

B200SR-IV: Ivory, Intelligent sounder base capable of producing sound output with ANSI Temporal 3 or continuous tone. Intended for retrofit applications. (CSFM: 7300-1653:0213 Pending)

B200SRA-WH: Same as B200SR-WH with, ULC listing.

B200SRA-IV: Same as B200SR-IV in Ivory color, ULC listing.

B200SR-LF-WH: White, Low Frequency Intelligent, programmable sounder base. Produces a fundamental frequency of 520 Hz +/- 10% with a square wave or its equivalent; designed to meet the NFPA 72 sleeping space requirement. Intended for retrofit applications. (CSFM: 7300-1653:0238 Pending)

B200SR-LF-IV: Ivory, Low Frequency Intelligent, programmable sounder base. Produces a fundamental frequency of 520 Hz +/- 10% with a square wave or its equivalent; designed to meet the NFPA 72 sleeping space requirement. Intended for retrofit applications. (CSFM: 7300-1653:0238 Pending)

MOUNTING KITS AND ACCESSORIES

TR300: White, replacement flange for B210LP(A) base.

TR300-IV: Ivory, replacement flange for B210LP(A) base.

RA100Z(A): Remote LED annunciator. 3 – 32 VDC. Mounts to a U.S. single-gang electrical box. For use with B501(A) and B300-6(A).

M02-04-00: Test magnet.

M02-09-00: Test magnet with telescoping handle.





NOTIFIER® and **FIREWARDEN®** are a registered trademark of Honeywell International Inc.

©2018 by Honeywell International Inc. All rights reserved. Unauthorized use of this document is strictly prohibited.



This document is not intended to be used for installation purposes.
We try to keep our product information up-to-date and accurate.
We cannot cover all specific applications or anticipate all requirements.
All specifications are subject to change without notice.

For more information, contact Notifier. Phone: (800) 627-3473, FAX: (203) 484-7118.
www.notifier.com

DNR(A)/DNRW InnovairFlex

Intelligent Non-Relay Photoelectric Duct Smoke Detector



Intelligent Devices

General

The Notifier InnovairFlex® DNR(A) intelligent non-relay photoelectric duct smoke detector and DNRW watertight non-relay photoelectric duct smoke detector feature a pivoting housing that fits both square and rectangular footprints capable of mounting to a round or rectangular duct.

DNRW duct smoke detector, with its NEMA-4 rating, is listed as a watertight, UV resistant enclosure providing protection against falling dirt, rain, and windblown dust, splashing and hose directed water, allowing operators to use the detector in the most extreme environments.

These units sense smoke in the most challenging conditions, operating in airflow speeds of 100 to 4,000 feet per minute (0.5 to 20.32 m/s), temperatures of -4°F to 158°F (-20°C to 70°C), and a humidity range of 0 to 95 percent (non-condensing.)

An improved cover design isolates the sensor head, which allows for ease of maintenance. A cover tamper feature indicates a trouble signal for a removed or improperly installed sensor cover. The Notifier InnovairFlex housing provides a 3/4-inch conduit knockout and ample space to facilitate easy wiring and mounting of a relay module.

The Notifier InnovairFlex duct smoke detector can be customized to meet local codes and specifications without additional wiring. The new InnovairFlex product line is compatible with all previous Innovair models, including remote test accessories.

Features

- Photoelectric, integrated low-flow technology.
- Air velocity rating from 100 ft/min to 4,000 ft/min (0.5 m/s to 20.32 m/s).
- Versatile mounting options: square or rectangular configuration.
- Broad ranges for operating temperature (-4°F to 158°F, -20°C to 70°C) and humidity (0% to 95% non-condensing).
- Patented sampling tube installs from front or back of the detector with no tools required.
- Cover tamper signal.
- Increased wiring space with a newly added 3/4" conduit knockout.
- Available space within housing to accommodate mounting of a relay module.
- Easily accessible code wheels on sensor head (sold separately).
- Clear cover for convenient visual inspection.
- Remote testing capability.
- Requires com line power only.
- Accommodates the installation of an addressable relay module, sold separately, (FRM-1 or NC-100R) for applications requiring a Form-C relay.

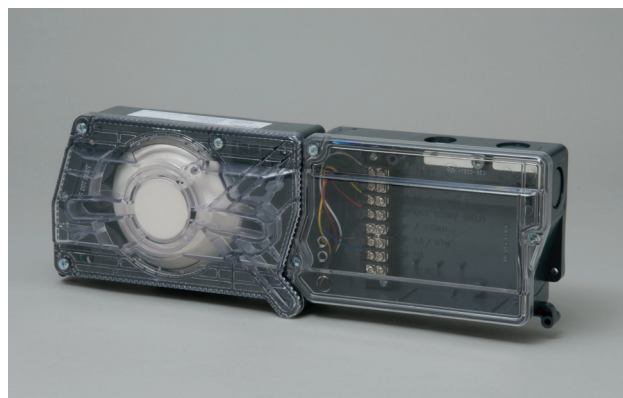

Specifications

Size: (Rectangle) 14.38 in (37 cm) Length; 5 in (12.7 cm) Width, 2.5 in (6.6 cm) Depth.

Size: (Square) 7.75 in (19.7 cm) Length; 9 in (22.9 cm) Width; 2.5 in (6.35 cm) Depth.

Weight: 1.6 lb (0.73 kg).

Operating Temperature Range: -4°F to 158°F (-20°C to 70°C).

Storage Temperature Range: -22°F to 158°F (-30°C to 70°C).

Operating Humidity Range: 0% to 95% relative humidity (non-condensing).

Air Duct Velocity: 100 to 4,000 ft/min (0.5 to 20.32 m/s).

Accessories

Notifier provides system flexibility with a variety of accessories, including two remote test stations and different means of visible and audible system annunciation. As with our duct smoke detectors, all duct smoke detectors accessories are UL listed.

DNR(W)s with a date code of 0013 or higher do not require external 24VDC for remote test applications when used with a remote-test-capable detector.

ACCESSORY CURRENT LOADS AT 24 VDC

Device	Standby	Alarm
RA100Z	0mA	12 mA Max
RTS151/ RTS151KEY	0mA	12mA Max

Agency Listings and Approvals

Consult product manual for lists of compatible UL-Listed devices. In some cases, certain modules may not be listed by certain approval agencies, or listing may be in process. Consult factory for latest listing status.

- **UL:** S911, S3705.
- **ULC:** S635.



Reviewed for Code Compliance
Permitting and Inspections
Department
Approved: 02/10/2020



- CSFM: 3242-1653:0209.
- FM approved.

Product Line Information

NOTE: "A suffix indicates ULC listed model.

DNR(A): Intelligent non-relay photoelectric low flow smoke detector housing. Requires photoelectric smoke detector (sold separately).

DNRW: Watertight intelligent non-relay photoelectric low flow duct smoke detector housing. Requires photoelectric smoke detector (sold separately).

FSP-851R(A): Remote test capable addressable low-profile photoelectric smoke detector.

FSP-851(A): Addressable low-profile photoelectric smoke detector.

NP-100: Addressable low-profile photoelectric smoke detector for FireWarden series panels.

NP-100R(A): Remote test capable addressable low-profile photoelectric smoke detector for FireWarden series panels.

DCOIL: Remote test coil. Required for older DNR(W) duct detector housing.

DST1(A): Metal sampling tube duct width up to 1 ft (0.3m).

DST1.5(A): Metal sampling tube duct widths up to 1 ft to 2 ft (0.3 to 0.6 m).

DST3(A): Metal sampling tube duct widths up to 2 ft to 4 ft (0.6 to 1.2 m).

DST5(A): Metal sampling tube duct widths up to 4 ft to 8 ft (1.2 to 2.4 m).

DST10(A): Metal sampling tube duct widths up to 8 ft to 12 ft (2.4 to 3.7 m).

DH400OE-1: Weatherproof enclosure.

ETX: Metal exhaust tube duct, width 1 ft (0.3 m).

M02-04-00: Test magnet.

P48-21-00: End cap for metal sampling tubes.

RA100Z(A): Remote annunciator alarm LED.

RTS151(A): Remote test station.

RTS151KEY(A): Remote test station with key lock.

Important Note

- DNRW duct detector housings with a date code of 0013 or higher do not require a DCOIL or auxiliary 24 VDC for remote test applications when used with a remote test capable detector.
- DNRW duct detector housings with a date code of 0012 or earlier require a DCOIL and auxiliary 24 VDC power for remote test applications.

Notifier® and FlashScan® are a registered trademark of Honeywell International Inc.
©2012 by Honeywell International Inc. All rights reserved. Unauthorized use of this document is strictly prohibited.



This document is not intended to be used for installation purposes.
We try to keep our product information up-to-date and accurate.
We cannot cover all specific applications or anticipate all requirements.
All specifications are subject to change without notice.



For more information, contact Notifier. Phone: (203) 484-7161, FAX: (203) 484-7118.
www.notifier.com

Duct Smoke Detector Accessories

for Notifier/System Sensor Products



Miscellaneous

General

Duct smoke detector accessories add functionality to the duct smoke system by allowing quick, convenient inspections at eye level and effective audible and visual notification options. All System Sensor duct smoke detectors and accessories are UL listed.

Specifications

APA151 PIEZO ANNUNCIATOR

The **APA151** piezo annunciator, which replaces the APA451 with a new, improved look, provides an audible alarm signal, a red LED to indicate alarm status, and a green LED to indicate power status. It is intended for use with System Sensor 4-wire conventional duct smoke detector applications without a system control panel, to comply with NFPA 90A.



APA151.wmf

APA151 Piezo Annunciator	
Voltage	Regulated 24 VDC
Operating Voltage	16 to 33 VDC
Maximum Alarm Current	30 mA
Temperature Range	32°F to 120°F (0°C to 49°C)
Relative Humidity	10 to 93%, non-condensing
Wire Gauge	12 to 18 AWG
Dimensions	4.6" H x 2.9" W x .45" D

MHR/MHW MINI-HORNS

The **MHR** and **MHW** SpectrAlert® Advance mini-horns feature temporal or continuous tones at high and low volume settings. Their small footprint allows mounting to single-gang back boxes for applications where a small device is desired.



MHR.wmf, MHW.wmf



60535cov.wmf

MHR/MHW SpectrAlert Advance Mini-Horns	
Voltage	Regulated 12 DC or FWR (Full Wave Rectified) or Regulated 24 VDC or FWR
Operating Voltage	8 to 33 VDC (9 to 33 VDC with Sync-Circuit™ Module)
Sounder Current Draw	22 mA RMS max. at 8 to 17.5 Volts DC 17 mA RMS max. at 8 to 17.5 Volts FWR 29 mA RMS max. at 16 to 33 Volts DC 25 mA RMS max. at 16 to 33 Volts FWR
Temperature Range	32°F to 120°F (0°C to 49°C)
Humidity Range	10 to 93% non-condensing
Nominal Sounder Frequency	3 kHz
Wire Gauge	12 to 18 AWG
Dimensions	4.6"H x 2.9"W x 0.45"D



Reviewed for Code Compliance
Permitting and Inspections
Department
April 10, 2020

RA100Z/RA100ZA REMOTE ANNUNCIATORS

The **RA100Z** and **RA100ZA** remote annunciators are designed for both conventional and intelligent applications. Their red LED provides visual indication of an alarm condition.



RA100Z.wmf

RA100Z/RA100ZA Remote Annunciator	
Voltage Range	Conventional System: 3.1 to 32 VDC Intelligent System: 18 to 32 VDC
Maximum Alarm Current	10 mA
Dimensions	4.6"H x 2.8"W x 1.3"D

RTS151/RTS151KEY REMOTE TEST STATIONS

The **RTS151** and **RTS151KEY** remote test stations are automatic fire detector accessories designed to test duct smoke detectors from a convenient location. For 4-wire detectors, the **RTS151KEY** test station features a multi-colored LED that alternates between steady green and red. For 2-wire detectors, the LED illuminates red for alarm.



RTS151.wmf, RTS151KEY.wmf

RTS151 Remote Test Station	
Power Requirements	Alarm LED 2.8 to 32 VDC, 10 mA max. Total Current: 95 mA max.
Test Switch	10 VA @ 32 VDC
Reset Switch	10 VA @ 32 VDC
Alarm Response Time	40 seconds max.
Temperature Range	14°F to 140°F (-10°C to 60°C)
Relative Humidity	95% non-condensing
Wire Gauge	14 to 18 AWG
Dimensions	4.8"H x 2.9W x 1.4"D

RTS151KEY Remote Test Station with Key	
Power Requirements	Power LED (Green): 14 to 35 VDC, 12 mA max. Alarm LED (RED): 2.8 to 32 VDC, 12 mA max.
Alarm Response Time	40 seconds max.
Temperature Range	14°F to 140°F (-10°C to 60°C)
Relative Humidity	95% non-condensing
Wire Gauge	14 to 18 AWG
Dimensions	4.6"H x 2.75W x 1.8"D

RTS2/RTS-AOS MULTI-SIGNALLING ACCESSORIES

The **RTS2** and **RTS2-AOS** multi-signaling accessories are designed to work with InnovairFlex 4-wire conventional duct smoke detectors. These accessories include a key switch that can be used to select one of two connected sensors to be tested, reset, or both by a push button switch. They also enable sensitivity measurements using the SENS-RDR sensitivity reader (sold separately). The **AOS** (Add-On Strobe) is an optional accessory included with the **RTS2-AOS** model.



RTS-AOS.wmf, AOS.wmf

RTS2 and RTS-AOS Multi-Signaling Accessory	
Voltage	20 to 29 VDC
Power Requirements	Standby: 3.0 mA max. Trouble: 16.0 mA max. Alarm without Strobe: 30 mA max. Alarm with Strobe: 55 mA max.
Sounder	85 dBA at 10 ft.
Temperature Range	14°F to 140°F (-10°C to 60°C)
Relative Humidity	95% non-condensing
Wire Gauge	14 to 22 AWG
Dimensions	4.8"W x 5.3"H x 1.6"D



Reviewed for Code Compliance
Permitting and Inspections
Department
Approved: 02/10/2020

Product Line Information

APA151: Piezo Annunciator

MHR: Mini-Horn, Red

MHW: Mini-Horn, White

RA100Z/RA100ZA: Remote Annunciator

RTS151: Remote Test Station

RTS151KEY: Remote Test Station with Key

RTS2: Multi-signaling Accessory

AOS: Add-On Strobe

RTS2-AOS: Multi-Signaling Accessory

Temperature and Humidity Ranges

This system meets NFPA requirements for operation at 0 – 49°C/32 – 120°F and at a relative humidity 93% ± 2% RH (noncondensing) at 32°C ± 2°C (90°F ± 3°F). However, the useful life of the system's standby batteries and the electronic components may be adversely affected by extreme temperature ranges and humidity. Therefore, it is recommended that this system and its peripherals be installed in an environment with a normal room temperature of 15 – 27°C/60 – 80°F.

Agency Listings and Approvals

The listings and approvals below apply to the basic products. In some cases, certain modules may not be listed by certain approval agencies, or listing may be in process. Consult factory for latest listing status.

- **UL: S4011 (APA 151, MHR, MHW), S2522 (RTS2, RA100Z, RTS151, RTS151KEY, RTS2-AOS)**
- **FM Approved**
- **CSFM: 7135-1653:0212**



Reviewed for Code Compliance
Permitting and Inspections
Department
April 10, 2020



FlashScan®, **NOTIFIER®** and **System Sensor®** are registered trademarks of Honeywell International Inc.
©2012 by Honeywell International Inc. All rights reserved. Unauthorized use of this document is strictly prohibited.



This document is not intended to be used for installation purposes.
We try to keep our product information up-to-date and accurate.
We cannot cover all specific applications or anticipate all requirements.
All specifications are subject to change without notice.



Made in the U.S. A.

For more information, contact Notifier. Phone: (203) 484-7161, FAX: (203) 484-7118.
www.notifier.com

NC-100R(A)

Relay Module for FireWarden Series Panels

**Addressable**

General

The NC-100R(A) Addressable Relay Module provides NOTIFIER's FireWarden Series intelligent control panels with two isolated sets of Form-C dry-contact outputs for activating a variety of auxiliary devices, such as fans, dampers, door holders, control equipment, etc. Addressability allows the dry contact to be activated, either manually or through panel programming, on a select basis.

Features

- Built-in type identification automatically identifies these devices to the control panel.
- Internal circuitry and relay powered directly by two-wire SLC loop.
- Integral LED "blinks" green each time a communication is received from the control panel and turns on in steady when activated.
- High noise immunity (EMF/RFI).
- Wide viewing angle of LED.
- SEMS screws with clamping plates for wiring ease.
- Direct Decade entry of address: 01 – 99 with the FireWarden-100-2(C) and 01 – 50 with the FireWarden-50(C).

Applications

The NC-100R(A) may be programmed to operate dry contacts for door holders, Air Handling Unit shutdown, etc., and to reset four-wire smoke detector power.

Construction

- The face plate is made of off-white heat-resistant plastic.
- Controls include two rotary switches for direct-dial entry of address setting.
- The NC-100R(A) provides two Form-C dry contacts that switch together.

Operation

Each NC-100R(A) uses one of the addresses on a SLC loop. It responds to regular polls from the control panel and reports its type and status. The LED blinks with each poll received. On command, it activates its internal relay.

Rotary switches set a unique address for each module. The address may be set before or after mounting. The built-in TYPE CODE (not settable) will identify the module to the control panel.

**NC-100R(A)**

Reviewed for Code Compliance
Permitting and Inspections
Department
Approved 02/10/2020

60379cov.jpg

Specifications

Normal operating voltage: 15 to 32 VDC.

Maximum SLC current draw: 6.5 mA (LED).

Average operating current: 230 μ A direct poll (CLIP mode), 255 μ A group poll with LED flashing.

EOL resistance: not used.

Temperature range: 32°F to 120°F (0°C to 49°C).

Humidity range: 10% to 93% non-condensing.

Dimensions: 4.5" (11.43 cm) high x 4" (10.16 cm) wide x 1.25" (3.175 cm) deep. Mounts to a 4" (10.16 cm) square x 2.125" (5.398 mm) deep box.

Relay Contact Ratings

Load Description	Application	Maximum Voltage	Current Rating
Resistive	Non-Coded	30 VDC	3.0 A
Resistive	Coded	30 VDC	2.0 A
Resistive	Non-Coded	110 VDC	0.9 A
Resistive	Non-Coded	125 VAC	0.9 A
Inductive (L/R=5ms)	Coded	30 VDC	0.5 A
Inductive (L/R=2ms)	Coded	30 VDC	1.0 A
Inductive (PF=0.35)	Non-Coded	125 VAC	0.5 A



Agency Listings and Approvals

In some cases, certain modules may not be listed by certain approval agencies, or listing may be in process. Consult factory for latest listing status.

- **UL/ULC Listed:** S635.
- **CSFM approved:** file 7300-0028:230.
- **FM approved.**
- **MEA approved:** file 72-01-E, Vol. 2.

Product Line Information

NC-100R: Intelligent addressable relay module.

NC-100RA: Intelligent addressable relay module, ULC listed model.

SMB500: Optional surface-mount backbox.

NOTE: For installation instructions, see document 156-2593-001 and refer to the SLC Wiring Manual, document 52304.

NOTIFIER® is a registered trademark of Honeywell International Inc.
©2010 by Honeywell International Inc. All rights reserved. Unauthorized use of this document is strictly prohibited.



This document is not intended to be used for installation purposes.
We try to keep our product information up-to-date and accurate.
We cannot cover all specific applications or anticipate all requirements.
All specifications are subject to change without notice.



Made in the U.S. A.

For more information, contact Notifier. Phone: (203) 484-7161, FAX: (203) 484-7118.
www.notifier.com



Monitor Modules

NMM-100(A), NMM-100P(A), NZM-100(A), and NDM-100(A) for FireWarden Series Panels



Intelligent Addressable Devices

General

Four different monitor modules are available for Notifier's FireWarden Series intelligent control panels for a variety of applications. Monitor modules supervise a circuit of dry-contact input devices, such as conventional heat detectors and pull stations, or monitor and power a circuit of two-wire smoke detectors (NZM-100(A)).

NMM-100(A) is a standard-sized module (typically mounts to a 4" [10.16 cm] square box) that supervises either a Style D (Class A) or Style B (Class B) circuit of dry-contact input devices.

NMM-100P(A) is a miniature monitor module a mere 1.3" (3.302 cm) H x 2.75" (6.985 cm) W x 0.5" (1.270 cm) D that supervises a Style B (Class B) circuit of dry-contact input devices. Its compact design allows the NMM-100P(A) to be mounted in a single-gang box behind the device it monitors.

NZM-100(A) is a standard-sized module that monitors and supervises compatible two-wire, 24 volt, smoke detectors on a Style D (Class A) or Style B (Class B) circuit.

NDM-100(A) is a standard-sized dual monitor module that monitors and supervises two independent two-wire Style B (Class B) dry-contact initiating device circuits (IDCs) at two separate, consecutive addresses in intelligent, two-wire systems.

NMM-100(A) Monitor Module

- Built-in type identification automatically identifies this device as a monitor module to the control panel.
- Powered directly by two-wire SLC loop. No additional power required.
- High noise (EMF/RFI) immunity.
- SEMS screws with clamping plates for ease of wiring.
- Direct Decade entry of address: 01 – 99 on FireWarden-100-2, 01 – 50 on FireWarden-50.
- LED flashes during normal operation and latches on steady to indicate alarm.

The NMM-100(A) Monitor Module is intended for use in intelligent, two-wire systems, where the individual address of each module is selected using the built-in rotary switches. It provides either a two-wire or four-wire fault-tolerant Initiating Device Circuit (IDC) for normally-open-contact fire alarm and supervisory devices. The module has a panel-controlled LED indicator.

NMM-100(A) APPLICATIONS

Use to monitor a zone of four-wire smoke detectors, manual fire alarm pull stations, waterflow devices, or other normally-open dry-contact alarm activation devices. May also be used to monitor normally-open supervisory devices with special supervisory indication at the control panel. Monitored circuit may be wired as an NFPA Style B (Class B) or Style D (Class A) Initiating Device Circuit. A 47K ohm End-of-Line Resistor (provided) terminates the Style B circuit. No resistor is required for supervision of the Style D circuit.

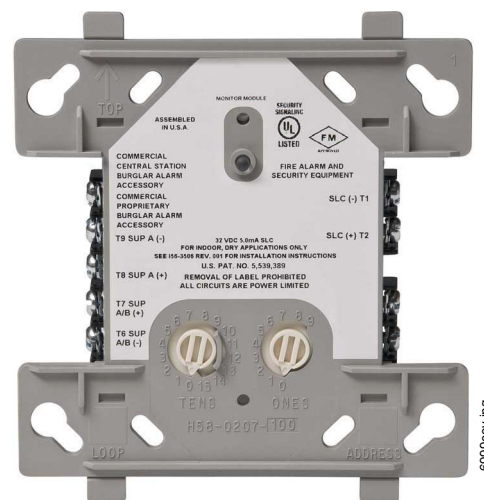

NMM-100(A) (Type H)

NMM-100(A) OPERATION

Each NMM-100(A) uses one of the available module addresses on an SLC loop. It responds to regular polls from the control panel and reports its type and the status (open/normal/short) of its Initiating Device Circuit (IDC). A flashing LED indicates that the module is in communication with the control panel. The LED latches steady on alarm (subject to current limitations on the loop).

NMM-100(A) SPECIFICATIONS

Nominal operating voltage: 15 to 32 VDC.

Maximum current draw: 5.0 mA (LED on).

Average operating current: 350 μ A (LED flashing), 1 communication every 5 seconds, 47k EOL.

Maximum IDC wiring resistance: 40 ohms.

EOL resistance: 47K ohms.

Temperature range: 32°F to 120°F (0°C to 49°C).

Humidity range: 10% to 93% noncondensing.

Dimensions: 4.5" (11.43 cm) high x 4" (10.16 cm) wide x 1.25" (3.175 cm) deep. Mounts to a 4" (10.16 cm) square x 2.125" (5.398 cm) deep box.

NMM-100P(A) Mini Monitor Module

- Built-in type identification automatically identifies this device as a monitor module to the panel.
- Powered directly by two-wire SLC loop. No additional power required.
- High noise (EMF/RFI) immunity.
- Tinned, stripped leads for ease of wiring.
- Direct Decade entry of address: 01 – 99 on FireWarden-100-2, 01 – 50 on FireWarden-50.

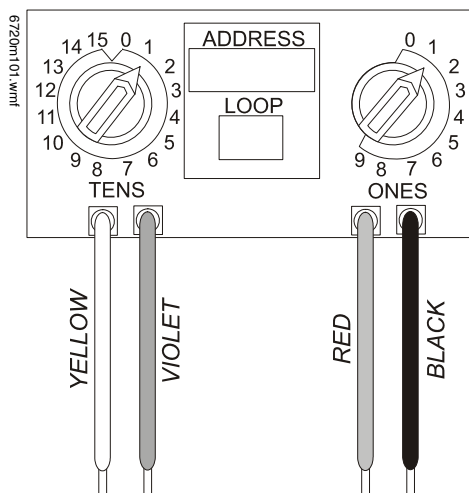

The NMM-100P(A) Mini Monitor Module can be installed in a single-gang junction directly behind the monitored unit. Its small size and light weight allow it to be installed without rigid mounting. The NMM-100P(A) is intended for use in intelligent, two-wire systems where the individual address of each module is selected using rotary switches. It provides a two-wire initiating device circuit for normally-open-contact fire alarm and security devices. NMM-100P(A)

NMM-100P(A) APPLICATIONS

Use to monitor a single device or a zone of four-wire smoke detectors, manual fire alarm pull stations, waterflow devices, or other normally-open dry-contact devices. May also be used to monitor normally-open supervisory devices with special supervisory indication at the control panel. Monitored circuit/device is wired as an NFPA Style B (Class B) Initiating Device Circuit. A 47K ohm End-of-Line Resistor (provided) terminates the circuit.

NMM-100P(A) OPERATION

Each NMM-100P(A) uses one of the available module addresses on an SLC loop. It responds to regular polls from the control panel and reports its type and the status (open/normal/short) of its Initiating Device Circuit (IDC).

NMM-100P(A) SPECIFICATIONS

Nominal operating voltage: 15 to 32 VDC.

Average operating current: 350 μ A, 1 communication every 5 seconds, 47k EOL; 600 μ A Max. (Communicating, IDC Shorted).

Maximum IDC wiring resistance: 40 ohms.

Maximum IDC Voltage: 11 Volts.

Maximum IDC Current: 400 μ A.

EOL resistance: 47K ohms.

Temperature range: 32°F to 120°F (0°C to 49°C).

Humidity range: 10% to 93% noncondensing.

Dimensions: 1.3" (3.302 cm) high x 2.75" (6.985 cm) wide x 0.65" (1.651 cm) deep.

Wire length: 6" (15.24 cm) minimum.

NZM-100(A) Interface Module

- Supports compatible two-wire smoke detectors.
- Supervises IDC wiring and connection of external power source.
- High noise (EMF/RFI) immunity.
- SEMS screws with clamping plates for ease of wiring.
- Direct Decade entry of address: 01 – 99 on FireWarden-100-2, 01 – 50 on FireWarden-50.
- LED flashes during normal operation.
- LED latches steady to indicate alarm on command from control panel.

The NZM-100(A) Interface Module is intended for use in intelligent, addressable systems, where the individual address of each module is selected using built-in rotary switches. This module allows intelligent panels to interface and monitor two-wire conventional smoke detectors. It transmits the status (normal, open, or alarm) of one full zone of conventional detectors back to the control panel. All two-wire detectors being monitored must be UL compatible with the module.

NZM-100(A) APPLICATIONS

Use the NZM-100(A) to monitor a zone of two-wire smoke detectors. The monitored circuit may be wired as an NFPA Style B (Class B) or Style D (Class A) Initiating Device Circuit. A 3.9 K ohm End-of-Line Resistor (provided) terminates the end of the Style B or D (class B or A) circuit (maximum IDC loop resistance is 25 ohms). Install ELR across terminals 8 and 9 for Style D application.

NZM-100(A) OPERATION

Each NZM-100(A) uses one of the available module addresses on an SLC loop. It responds to regular polls from the control panel and reports its type and the status (open/normal/short) of its Initiating Device Circuit (IDC). A flashing LED indicates that the module is in communication with the control panel. The LED latches steady on alarm (subject to current limitations on the loop).

NZM-100(A) SPECIFICATIONS

Nominal operating voltage: 15 to 32 VDC.

Maximum current draw: 5.1 mA (LED on).

Maximum IDC wiring resistance: 25 ohms.

Average operating current: 300 μ A, 1 communication and 1 LED flash every 5 seconds, 3.9k eol.

EOL resistance: 3.9K ohms.

External supply voltage (between Terminals T3 and T4): DC voltage: 24 volts power limited. Ripple voltage: 0.1 Vrms maximum. Current: 90 mA per module maximum.

Temperature range: 32°F to 120°F (0°C to 49°C).

Humidity range: 10% to 93% noncondensing.

Dimensions: 4.5" (11.43 cm) high x 4" (10.16 cm) wide x 1.25" (3.175 cm) deep. Mounts to a 4" (10.16 cm) square x 2.125" (5.398 cm) deep box.



NDM-100(A) Dual Monitor Module

The NDM-100(A) Dual Monitor Module is intended for use in intelligent, two-wire systems. It provides two independent two-wire initiating device circuits (IDCs) at two separate, consecutive addresses. It is capable of monitoring normally open contact fire alarm and supervisory devices. The module has a single panel-controlled LED.

NOTE: The NDM-100(A) provides two Style B (Class B) IDC circuits ONLY. Style D (Class A) IDC circuits are NOT supported in any application.

NDM-100(A) SPECIFICATIONS

Normal operating voltage range: 15 to 32 VDC.

Maximum current draw: 6.4 mA (LED on).

Average operating current: 750 μ A (LED flashing).

Maximum IDC wiring resistance: 1,500 ohms.

Maximum IDC Voltage: 11 Volts.

Maximum IDC Current: 240 μ A

EOL resistance: 47K ohms.

Maximum SLC Wiring resistance: 40 Ohms.

Temperature range: 32° to 120°F (0° to 49°C).

Humidity range: 10% to 93% (non-condensing).

Dimensions: 4.5" (11.43 cm) high x 4" (10.16 cm) wide x 2.125" (5.398 cm) deep.

NDM-100(A) AUTOMATIC ADDRESSING

The NDM-100(A) automatically assigns itself to two addressable points, starting with the original address. For example, if the NDM-100(A) is set to address "26", then it will automatically assign itself to addresses "26" and "27".

NOTE: "Ones" addresses on the NDM-100(A) are 0, 2, 4, 6, or 8 only. Terminals 6 and 7 use the first address, and terminals 8 and 9 use the second address.



CAUTION:

Avoid duplicating addresses on the system.

Installation

NMM-100(A), NZM-100(A), and NDM-100(A) modules mount directly to a standard 4" (10.16 cm) square, 2.125" (5.398 cm) deep, electrical box. They may also be mounted to the SMB500 surface-mount box. Mounting hardware and installation instructions are provided with each module. All wiring must conform to applicable local codes, ordinances, and regulations. These modules are intended for power-limited wiring only.

The NMM-100P(A) module is intended to be wired and mounted without rigid connections inside a standard electrical box. All wiring must conform to applicable local codes, ordinances, and regulations.

Agency Listings and Approvals

In some cases, certain modules may not be listed by certain approval agencies, or listing may be in process. Consult factory for latest listing status.

- **UL:** S635
- **ULC:** S635
- **FM Approved**
- **CSFM:** 7300-0028:0230 (NMM-100, NMM-100P, NZM-100); 7300-0028:0237 (NDM-100)

- **MEA:** 72-01-E Vol. 2 (NMM-100, NMM-100P, NZM-100); 227-03-E Vol. 3 (NDM-100)

Product Line Information

NOTE: "A" suffix indicates ULC-listed model.

NMM-100(A): Monitor module.

NMM-100P(A): Monitor module, miniature.

NZM-100(A): Monitor module, two-wire detectors.

NDM-100(A): Monitor module, dual, two independent Class B circuits.

SMB500: Optional surface-mount backbox.

NOTE: See installation instructions and refer to the SLC Wiring Manual, PN 52304.



Reviewed for Code Compliance
Permitting and Inspections
Department
Approved 02/10/2020



Notifier® and FireWarden® are registered trademarks and FireWatch™ is a trademark of Honeywell International Inc.
©2010 by Honeywell International Inc. All rights reserved. Unauthorized use of this document is strictly prohibited.



This document is not intended to be used for installation purposes.
We try to keep our product information up-to-date and accurate.
We cannot cover all specific applications or anticipate all requirements.
All specifications are subject to change without notice.



Made in the U.S. A.

For more information, contact Notifier. Phone: (203) 484-7161, FAX: (203) 484-7118.
www.notifier.com



Indoor Selectable-Output Horns, Strobes, and Horn Strobes for Wall Applications

System Sensor L-Series audible visible notification products are rich with features guaranteed to cut installation times and maximize profits with lower current draw and modern aesthetics.

Features

- Updated Modern Aesthetics
- Small profile devices for Horns and Horn Strobes
- Plug-in design with minimal intrusion into the back box
- Tamper-resistant construction
- Automatic selection of 12- or 24-volt operation at 15 and 30 candela
- Field-selectable candela settings on wall units: 15, 30, 75, 95, 110, 135, and 185
- Horn rated at 88+ dBA at 16 volts
- Rotary switch for horn tone and two volume selections
- Mounting plate for all standard and all compact wall units
- Mounting plate shorting spring checks wiring continuity before device installation
- Electrically compatible with legacy SpectrAlert and SpectrAlert Advance devices
- Compatible with MDL3 sync module
- Strobes and Horn Strobes listed for wall mounting only
- Horns listed for wall or ceiling use

Agency Listings



S5512
S4011



FM approved except
for ALERT models
3057383, 3057072



7125-1653:0504
7135-1653:0503



The System Sensor L-Series offers the most versatile and easy-to-use line of horns, strobes, and horn strobes in the industry with lower current draws and modern aesthetics. With white and red plastic housings, standard and compact devices, and plain, FIRE, and FUEGO-printed devices, System Sensor L-Series can meet virtually any application requirement.

The L-Series line of wall-mount horns, strobes, and horn strobes include a variety of features that increase their application versatility while simplifying installation. All devices feature plug-in designs with minimal intrusion into the back box, making installations fast and foolproof while virtually eliminating costly and time-consuming ground faults.

To further simplify installation and protect devices from construction damage, the L-Series utilizes a universal mounting plate for all models with an onboard shorting spring, so installers can test wiring continuity before the device is installed.

Installers can also easily adapt devices to a suit a wide range of application requirements using field-selectable candela settings, automatic selection of 12- or 24-volt operation, and a rotary switch for horn tones with two volume selections.



Reviewed for Code Compliance
Permitting and Inspections
Department
Approved for 02/10/2020



L-Series Specifications

Architect/Engineer Specifications

General

L-Series standard horns, strobes, and horn strobes shall mount to a standard 2 x 4 x 1 7/8-inch back box, 4 x 4 x 1 1/2-inch back box, 4-inch octagon back box, or double-gang back box. L-Series compact products shall mount to a single-gang 2 x 4 x 1 7/8-inch back box. A universal mounting plate shall be used for mounting ceiling and wall products for all standard models and a separate universal mounting plate shall be used for mounting wall compact models. The notification appliance circuit wiring shall terminate at the universal mounting plate. Also, L-Series products, when used with the Sync•Circuit™ Module accessory, shall be powered from a non-coded notification appliance circuit output and shall operate on a nominal 12 or 24 volts. When used with the Sync•Circuit Module, 12-volt-rated notification appliance circuit outputs shall operate between 8.5 and 17.5 volts; 24-volt-rated notification appliance circuit outputs shall operate between 16.5 and 33 volts. Indoor L-Series products shall operate between 32 and 120 degrees Fahrenheit from a regulated DC or full-wave rectified unfiltered power supply. Strobes and horn strobes shall have field-selectable candela settings including 15, 30, 75, 95, 110, 135, and 185.

Strobe

The strobe shall be a System Sensor L-Series Model _____ listed to UL 1971 and shall be approved for fire protective service. The strobe shall be wired as a primary-signaling notification appliance and comply with the Americans with Disabilities Act requirements for visible signaling appliances, flashing at 1 Hz over the strobe's entire operating voltage range. The strobe light shall consist of a xenon flash tube and associated lens/reflector system.

Horn Strobe Combination

The horn strobe shall be a System Sensor L-Series Model _____ listed to UL 1971 and UL 464 and shall be approved for fire protective service. The horn strobe shall be wired as a primary-signaling notification appliance and comply with the Americans with Disabilities Act requirements for visible signaling appliances, flashing at 1 Hz over the strobe's entire operating voltage range. The strobe light shall consist of a xenon flash tube and associated lens/reflector system. The horn shall have two audibility options and an option to switch between a temporal three pattern and a non-temporal (continuous) pattern. These options are set by a multiple position switch. The horn on horn strobe models shall operate on a coded or non-coded power supply.

Synchronization Module

The module shall be a System Sensor Sync•Circuit model MDL3 listed to UL 464 and shall be approved for fire protective service. The module shall synchronize Strobes at 1 Hz and horns at temporal three. Also, while operating the strobes, the module shall silence the horns on horn strobe models over a single pair of wires. The module shall mount to a 4 11/16 x 4 11/16 x 2 1/8-inch back box. The module shall also control two Style Y (class B) circuits or one Style Z (class A) circuit. The module shall synchronize multiple zones. Daisy chaining two or more synchronization modules together will synchronize all the zones they control. The module shall not operate on a coded power supply.

Physical/Electrical Specifications

Standard Operating Temperature	32°F to 120°F (0°C to 49°C)
Humidity Range	10 to 93% non-condensing
Strobe Flash Rate	1 flash per second
Nominal Voltage	Regulated 12 DC or regulated 24 DC/FWR ¹
Operating Voltage Range²	8 to 17.5 V (12 V nominal) or 16 to 33 V (24 V nominal)
Operating Voltage Range MDL3 Sync Module	8.5 to 17.5 V (12 V nominal) or 16.5 to 33 V (24 V nominal)
Input Terminal Wire Gauge	12 to 18 AWG
Wall-Mount Dimensions (including lens)	5.6" L x 4.7" W x 1.91" D (143 mm L x 119 mm W x 49 mm D)
Compact Wall-Mount Dimensions (including lens)	5.26" L x 3.46" W x 1.91" D (133 mm L x 88 mm W x 49 mm D)
Horn Dimensions	5.6" L x 4.7" W x 1.25" D (143 mm L x 119 mm W x 32 mm D)
Compact Horn Dimensions	5.25" L x 3.45" W x 1.25" D (133 mm L x 88 mm W x 32 mm D)

1. Full Wave Rectified (FWR) voltage is a non-regulated, time-varying power source that is used on some power supply and panel outputs.
2. Strobe products will operate at 12 V nominal only for 15 cd and 30 cd.



UL Current Draw Data

UL Max. Strobe Current Draw (mA RMS)				
Candela Range	Candela	8–17.5 Volts		
		DC	16–33 Volts DC	FWR
Candela Range	15	88	43	60
	30	143	63	83
	75	N/A	107	136
	95	N/A	121	155
	110	N/A	148	179
	135	N/A	172	209
	185	N/A	222	257

UL Max. Horn Current Draw (mA RMS)				
Sound Pattern	dB	8–17.5 Volts		
		DC	16–33 Volts DC	FWR
Temporal	High	39	44	54
Temporal	Low	28	32	54
Non-Temporal	High	43	47	54
Non-Temporal	Low	29	32	54
3.1 KHz Temporal	High	39	41	54
3.1 KHz Temporal	Low	29	32	54
3.1 KHz Non-Temporal	High	42	43	54
3.1 KHz Non-Temporal	Low	28	29	54
Coded	High	43	47	54
3.1 KHz Coded	High	42	43	54

UL Max. Current Draw (mA RMS), Wall Horn Strobe, Candela Range (15–185 cd)										
DC Input	8–17.5 Volts		16–33 Volts							
	15cd	30cd	15cd	30cd	75cd	95cd	110cd	135cd	185cd	
Temporal High	98	158	54	74	121	142	162	196	245	
Temporal Low	93	154	44	65	111	133	157	184	235	
Non-Temporal High	106	166	73	94	139	160	182	211	262	
Non-Temporal Low	93	156	51	71	119	139	162	190	239	
3.1K Temporal High	93	156	53	73	119	140	164	190	242	
3.1K Temporal Low	91	154	45	66	112	133	160	185	235	
3.1K Non-Temporal High	99	162	69	90	135	157	175	208	261	
3.1K Non-Temporal Low	93	156	52	72	119	138	162	192	242	
FWR Input	16–33 Volts									
	15cd	30cd	75cd	95cd	110cd	135cd	185cd			
Temporal High	83	107	156	177	198	234	287			
Temporal Low	68	91	145	165	185	223	271			
Non-Temporal High	111	135	185	207	230	264	316			
Non-Temporal Low	79	104	157	175	197	235	283			
3.1K Temporal High	81	105	155	177	196	234	284			
3.1K Temporal Low	68	90	145	166	186	222	276			
3.1K Non-Temporal High	104	131	177	204	230	264	326			
3.1K Non-Temporal Low	77	102	156	177	199	234	291			

Horn Tones and Sound Output Data

Horn and Horn Strobe Output (dBA)					
Switch Position	Sound Pattern	dB	8–17.5 Volts	16–33 Volts	FWR
			DC	DC	
1	Temporal	High	84	89	89
2	Temporal	Low	75	83	83
3	Non-Temporal	High	85	90	90
4	Non-Temporal	Low	76	84	84
5	3.1 KHz Temporal	High	83	88	88
6	3.1 KHz Temporal	Low	76	82	82
7	3.1 KHz Non-Temporal	High	84	89	89
8	3.1 KHz Non-Temporal	Low	77	83	83
9*	Coded	High	85	90	90
10*	3.1 KHz Coded	High	84	89	89

* Settings 9 and 10 are not available on 2-wire horn strobes. Temporal coding must be provided by the NAC. If the NAC voltage is held constant, the horn output remains constantly on.



L-Series Dimensions

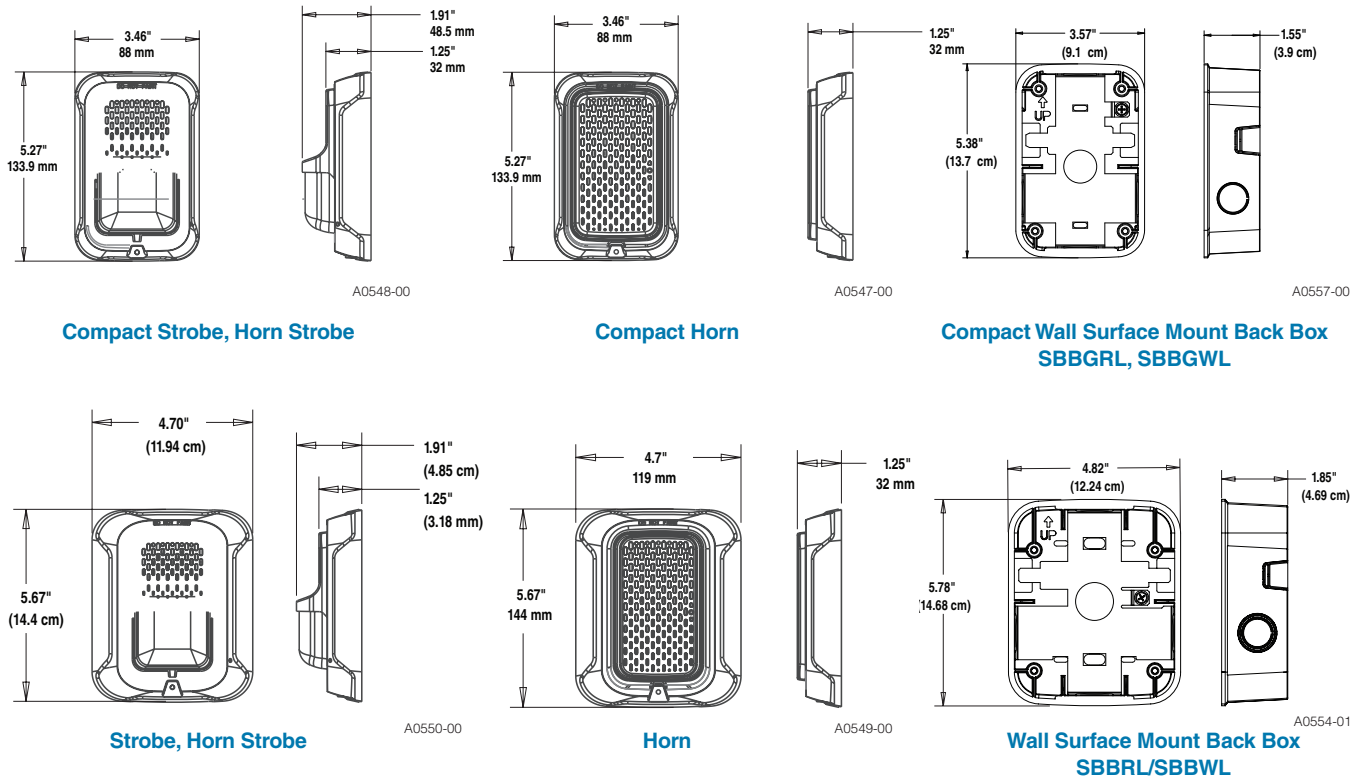

L-Series Ordering Information

Model	Description
Wall Horn Strobes	
P2RL	2-Wire, Horn Strobe, Red
P2WL	2-Wire, Horn Strobe, White
P2GRL	2-Wire, Compact Horn Strobe, Red
P2GWL	2-Wire, Comp 2 fils act Horn Strobe, White
P2RL-P	2-Wire, Horn Strobe, Red, Plain
P2WL-P	2-Wire, Horn Strobe, White, Plain
P2RL-SP	2-Wire, Horn Strobe, Red, FUEGO
P2WL-SP	2-Wire, Horn Strobe, White, FUEGO
P4RL	4-Wire, Horn Strobe, Red
P4WL	4-Wire, Horn Strobe, White
Wall Strobes	
SRL	Strobe, Red
SWL	Strobe, White
SGRL	Compact Strobe, Red
SGWL	Compact Strobe, White
SRL-P	Strobe, Red, Plain
SWL-P	Strobe, White, Plain
SRL-SP	Strobe, Red, FUEGO
SWL-CLR-ALERT	Strobe, White, ALERT

Model	Description
Horns*	
HRL*	Horn, Red
HWL*	Horn, White
HGRL*	Compact Horn, Red
HGWL*	Compact Horn, White
Accessories	
TR-2	Universal Wall Trim Ring Red
TR-2W	Universal Wall Trim Ring White
SBBRL	Wall Surface Mount Back Box, Red
SBBWL	Wall Surface Mount Back Box, White
SBBGRL	Compact Wall Surface Mount Back Box, Red
SBBGWL	Compact Wall Surface Mount Back Box, White

Notes:

- All -P models have a plain housing (no "FIRE" marking on cover).
- All -SP models have "FUEGO" marking on cover.
- All -ALERT models have "ALERT" marking on cover.
- *Horn-only models are listed for wall or ceiling use.





Outdoor Selectable- Output Horns, Strobes, and Horn Strobes for Wall Applications



SpectrAlert® Advance outdoor audible visible products are rich with features that cut installation times and maximize profits.

Features

- Weatherproof per NEMA 4X, IP56
- Listed to UL 1638 (strobe) and UL 464 (horn)
- Compatible with System Sensor synchronization protocol and legacy SpectrAlert products
- Field-selectable candela settings: 15, 15/75, 30, 75, 95, 110, 115, 135, 150, 177, and 185
- Automatic selection of 12- or 24-volt operation at 15 and 15/75 candela
- Rotary switch for horn tone and three volume selections
- Horn rated at 88+ dBA at 16 volts
- Rated from -40°F to 151°F
- Universal mounting plate with an onboard shorting spring that tests wiring continuity before devices are installed
- Plug-in design with minimal intrusion into the back box
- Tamper-resistant construction
- Listed for ceiling or wall mounting

SpectrAlert Advance offers the broadest line of outdoor horns, strobes, and horn strobes in the industry. With white or red plastic housings, wall or ceiling mounting options, and plain or FIRE-printed devices, SpectrAlert Advance can meet virtually any application requirement, including indoor, outdoor, wet, and dry applications in temperatures from -40°F to 151°F.

Like the entire SpectrAlert Advance line, outdoor horns, strobes, and horn strobes for wall applications include a variety of features that increase application flexibility and simplify installation. First, field-selectable settings, including candela, automatic selection of 12- or 24-volt operation, horn tones, and three volume options enable installers to easily adapt devices to meet requirements.

Next, SpectrAlert Advance devices use a universal mounting plate for both wall and ceiling applications. This mounting plate includes an onboard shorting spring that ensures wiring continuity before devices are installed, so installers can verify proper wiring without mounting the devices and exposing them to potential construction damage. Once the plates are mounted, all SpectrAlert Advance devices utilize a plug-in design with a single captured screw to speed installation and virtually eliminate costly ground faults.

Outdoor devices ship with weatherproof plastic back boxes (metal back boxes are available separately) that accommodate in-and-out wiring for daisy chaining devices. Plastic back boxes feature removable side flanges and improved resistance to saltwater corrosion. Knock-outs located on the back eliminate the need to drill holes for screw-in mounting. Plastic and metal weatherproof back boxes come with 3/4-inch top and bottom conduit entries and 3/4-inch knock-outs at the back. A screw-in NPT plug with an O-ring gasket for a watertight seal is included with each back box.

Agency Listings



S4011 (chimes, horn strobes, horns)
S3593 (outdoor and alert strobes)



3023572



MEA452-05-E



7300-1653-187 (outdoor strobes)
7125-1653-188 (horn strobes,
chime strobes)
7135-1653-189 (horns, chimes)



SpectrAlert Advance Outdoor Horn, Strobe, and Horn Strobe Specifications

Architect/Engineer Specifications

General

SpectrAlert Advance outdoor horns, strobes, and horn strobes shall mount to a weatherproof back box. A universal mounting plate shall be used for mounting ceiling and wall products. The notification appliance circuit wiring shall terminate at the universal mounting plate. Also, SpectrAlert Advance products, when used with the Sync•Circuit™ Module accessory, shall be powered from a non-coded notification appliance circuit output and shall operate on a nominal 12 or 24 volts. When used with the Sync•Circuit Module, 12-volt-rated notification appliance circuit outputs shall operate between 9 and 17.5 volts; 24-volt-rated notification appliance circuit outputs shall operate between 17 and 33 volts. Outdoor SpectrAlert Advance products shall operate between –40 and 151 degrees Fahrenheit from a regulated DC or full-wave rectified unfiltered power supply. Strobes and horn strobes shall have field-selectable candela settings including 15, 15/75, 30, 75, 95, 110, 115, 135, 150, 177, and 185.

Strobe

The strobe shall be a System Sensor SpectrAlert Advance Model _____ listed to UL 1971 and shall be approved for fire protective service. The strobe shall be wired as a primary-signaling notification appliance and comply with the Americans with Disabilities Act requirements for visible signaling appliances, flashing at 1 Hz over the strobe's entire operating voltage range. The strobe light shall consist of a xenon flash tube and associated lens/reflector system. The strobe must be installed with its weatherproof back box in order to remain outdoor approved per UL. The strobe shall be suitable for use in wet environments.

Horn Strobe Combination

The horn strobe shall be a System Sensor SpectrAlert Advance Model _____ listed to UL 1971 and UL 464 and shall be approved for fire protective service. The horn strobe shall be wired as a primary-signaling notification appliance and comply with the Americans with Disabilities Act requirements for visible signaling appliances, flashing at 1 Hz over the strobe's entire operating voltage range. The strobe light shall consist of a xenon flash tube and associated lens/reflector system. The horn shall have three audibility options and an option to switch between a temporal three pattern and a non-temporal (continuous) pattern. These options shall be set by a multiple position switch. On four-wire products, the strobe shall be powered independently of the sounder. The horn or horn strobe models shall operate on a coded or non-coded power supply. The horn strobe must be installed with its weatherproof back box in order to remain outdoor approved per UL. The horn strobe shall be suitable for use in wet environments.

Physical/Electrical Specifications

Operating Temperature	–40°F to 151°F (–40°C to 66°C)
Strobe Flash Rate	1 flash per second
Nominal Voltage	Regulated 12 DC/FWR or regulated 24 DC/FWR ¹
Operating Voltage Range²	8 to 17.5 V (12 V nominal) or 16 to 33 V (24 V nominal)
Input Terminal Wire Gauge	12 to 18 AWG
Wall-Mount Dimensions (including lens)	5.6" L x 4.7" W x 2.5" D (142 mm L x 119 mm W x 64 mm D)
Horn Dimensions	5.6" L x 4.7" W x 1.3" D (142 mm L x 119 mm W x 33 mm D)
Wall-Mount Weatherproof Back Box Dimensions (SA-WBB)	5.7" L x 5.1" W x 2.0" D (145 mm L x 130 mm W x 51 mm D)

Notes:

1. Full Wave Rectified (FWR) voltage is a non-regulated, time-varying power source that is used on some power supply and panel outputs.
2. P, S, PC, and SC products will operate at 12 V nominal only for 15 and 15/75 cd.



UL Current Draw Data

UL Max. Strobe Current Draw (mA RMS)						UL Max. Horn Current Draw (mA RMS)					
	Candela	8–17.5 Volts		16–33 Volts		Sound Pattern	dB	8–17.5 Volts		16–33 Volts	
		DC	FWR	DC	FWR			DC	FWR	DC	FWR
Standard Candela Range	15	123	128	66	71	Temporal	High	57	55	69	75
	15/75	142	148	77	81	Temporal	Medium	44	49	58	69
	30	NA	NA	94	96	Temporal	Low	38	44	44	48
	75	NA	NA	158	153	Non-Temporal	High	57	56	69	75
	95	NA	NA	181	176	Non-Temporal	Medium	42	50	60	69
	110	NA	NA	202	195	Non-Temporal	Low	41	44	50	50
	115	NA	NA	210	205	Coded	High	57	55	69	75
High Candela Range	135	NA	NA	228	207	Coded	Medium	44	51	56	69
	150	NA	NA	246	220	Coded	Low	40	46	52	50
	177	NA	NA	281	251						
	185	NA	NA	286	258						

UL Max. Current Draw (mA RMS), 2-Wire Horn Strobe, Standard Candela Range (15–115 cd)										
DC Input	8–17.5 Volts			16–33 Volts						
	15	15/75	30	15	15/75	30	75	95	110	115
Temporal High	137	147	79	90	107	176	194	212	218	218
Temporal Medium	132	144	69	80	97	157	182	201	210	210
Temporal Low	132	143	66	77	93	154	179	198	207	207
Non-Temporal High	141	152	91	100	116	176	201	221	229	229
Non-Temporal Medium	133	145	75	85	102	163	187	207	216	216
Non-Temporal Low	131	144	68	79	96	156	182	201	210	210
FWR Input										
Temporal High	136	155	88	97	112	168	190	210	218	218
Temporal Medium	129	152	78	88	103	160	184	202	206	206
Temporal Low	129	151	76	86	101	160	184	194	201	201
Non-Temporal High	142	161	103	112	126	181	203	221	229	229
Non-Temporal Medium	134	155	85	95	110	166	189	208	216	216
Non-Temporal Low	132	154	80	90	105	161	184	202	211	211

UL Max. Current Draw (mA RMS), 2-Wire Horn Strobe, High Candela Range (135–185 cd)									
DC Input	16–33 Volts				FWR Input	16–33 Volts			
	135	150	177	185		135	150	177	185
Temporal High	245	259	290	297	Temporal High	215	231	258	265
Temporal Medium	235	253	288	297	Temporal Medium	209	224	250	258
Temporal Low	232	251	282	292	Temporal Low	207	221	248	256
Non-Temporal High	255	270	303	309	Non-Temporal High	233	248	275	281
Non-Temporal Medium	242	259	293	299	Non-Temporal Medium	219	232	262	267
Non-Temporal Low	238	254	291	295	Non-Temporal Low	214	229	256	262

Candela Derating

For K series products used at low temperatures, listed candela ratings must be reduced in accordance with this table.

Strobe Output (cd)	
Listed Candela	Candela rating at –40°F
15	Do not use below 32°F
15/75	
30	
75	
95	44
110	70
115	110
135	115
150	135
177	150
185	177

Horn Tones and Sound Output Data

Horn and Horn Strobe Output (dBA)											
Switch Position	Sound Pattern	dB	8–17.5 Volts		16–33 Volts		24-Volt Nominal				
			DC	FWR	DC	FWR	Reverberant		Anechoic		
			DC	FWR	DC	FWR	DC	FWR	DC	FWR	
1	Temporal	High	78	78	84	84	88	88	99	98	
2	Temporal	Medium	74	74	80	80	86	86	96	96	
3	Temporal	Low	71	73	76	76	83	80	94	89	
4	Non-Temporal	High	82	82	88	88	93	92	100	100	
5	Non-Temporal	Medium	78	78	85	85	90	90	98	98	
6	Non-Temporal	Low	75	75	81	81	88	84	96	92	
7†	Coded	High	82	82	88	88	93	92	101	101	
8†	Coded	Medium	78	78	85	85	90	90	97	98	
9†	Coded	Low	75	75	81	81	88	85	96	92	

†Settings 7, 8, and 9 are not available on 2-wire horn strobe.



SpectrAlert Advance Diagrams

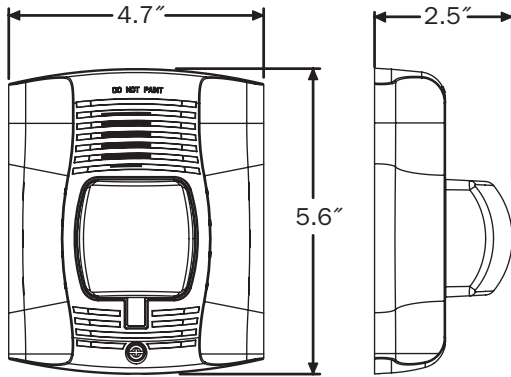

Wall-Mount Horn Strobes

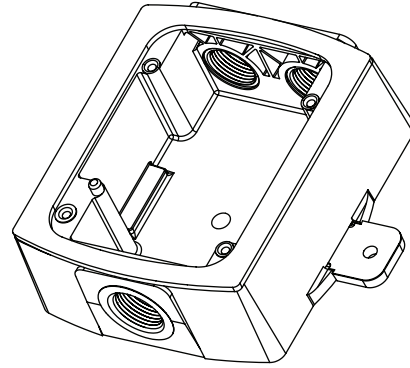

Wall Plastic Weatherproof Back Box

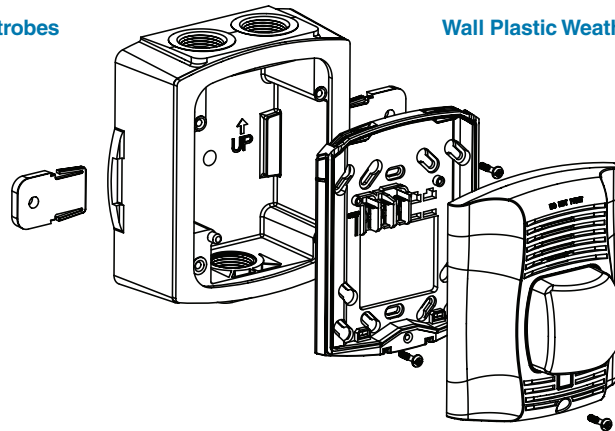

Wall-Mount Horn Strobe with Plastic Weatherproof Back Box

SpectrAlert Advance Ordering Information

Model	Description
Wall Horn Strobes	
P2RK*†	2-Wire Horn Strobe, Standard cd, Red, Outdoor (includes plastic weatherproof back box)
P2RHK*†	2-Wire Horn Strobe, High cd, Red, Outdoor (includes plastic weatherproof back box)
P2WK*†	2-Wire Horn Strobe, Standard cd, White, Outdoor (includes plastic weatherproof back box)
P2WHK*†	2-Wire Horn Strobe, High cd, White, Outdoor (includes plastic weatherproof back box)
P4RK†	4-Wire Horn Strobe, Standard cd, Red, Outdoor (includes plastic weatherproof back box)
P4WK	4-Wire Horn Strobe, Standard cd, White, Outdoor (includes plastic weatherproof back box)
P2RHK-120	2-Wire Horn Strobe, High cd, Red, Outdoor, 120 V (includes plastic weatherproof back box)
Wall Strobes	
SRK*†	Strobe, Standard cd, Red, Outdoor (includes plastic weatherproof back box)
SRHK*†	Strobe, High cd, Red, Outdoor (includes plastic weatherproof back box)
SWK*†	Strobe, Standard cd, White, Outdoor (includes plastic weatherproof back box)
SWHK*†	Strobe, High cd, White, Outdoor (includes plastic weatherproof back box)
Horns	
HRK†	Horn, Red, Outdoor (includes plastic weatherproof back box)
Accessories	
SA-WBB	Red, Metal Weatherproof Back Box
SA-WBBW	White, Metal Weatherproof Back Box

Notes:

* Add "-P" to model number for plain housing (no "FIRE" marking on cover), e.g., P2RK-P.

† Add "-R" to model number for weatherproof replacement device (no back box included), only for use with weatherproof outdoor flush mounting plate, WTP and WTPW. "Standard cd" refers to strobes that include 15, 15/75, 30, 75, 95, 110, and 115 candela settings. "High cd" refers to strobes that include 135, 150, 177, and 185 candela settings. **When replacing standard outdoor units both the device and back box must be replaced.**



**NO
EXCUSES!**

SIGNALING



SYSTEM RECORD DOCUMENTS

The SRD is the perfect item to help you meet demanding code requirements today. NFPA 72 2013 7.7.2.4 states that a cabinet must be "prominently labelled 'SYSTEM RECORD DOCUMENTS'."

The SRD is the perfect fit to meet today's demanding code requirements. SAE's number one goal is to manufacture code compliant solutions and this product allows you to do just that. NFPA 72 2013 7.7.2.1 states, "With every new system, a documentation cabinet shall be installed at the system control unit or other approved location at the protected premises."

This durable 16 gauge steel enclosure with a solid piano hinge and key lock will keep all of your code required documents in one safe place. With a 4GB USB flash drive it stores your fire alarm software safe and secure eliminating the occurrences of the software not being on site when technicians arrive to service the system. Along with your fire alarm software you can store your test & inspection, service records, manuals & system records. Using a standard USB B connector you may also store your records electronically (See NFPA 72 2013 7.5.6.7).

The SRD has designated hooks to organize key rings and hold important business cards for easy access and reference. Inside the cover it has an organized record for identifying equipment information, required documentation locations (See NFPA 72 2013 7.2.1).

Standard Features:

- Installed with a 4 GB digital flash drive with USB B connector
- 2 key ring hooks to hold system keys
- Business card holder for key contacts
- Overall dimensions are 12" x 13" tall and 2 1/4" deep
- 18 gauge steel box and cover for security
- Durable powder coat baked on finish other colors available
- Standard 3/4" cat 30 key lock. Other lock assemblies available
- Solid stainless steel piano hinge
- Permanently screened white ink 1" high "SYSTEM RECORD DOCUMENTS"
- Legend sheet for documentation, passwords and system information



Reviewed for Code Compliance
Permitting and Inspections
Department
April 10, 2020



**ISO 9001
REGISTERED
COMPANY**

ACEBOX

Space Age Electronics, Inc.
www.1sae.com
800.486.1723 Toll Free
508.485.0966 Local
508.485.4740 Fax

Specifications:

The system record documents box (SRD) shall be UL Listed, constructed of 18 gauge cold rolled steel. It shall have a red powder coat epoxy finish. The cover shall be permanently screened with 1" high lettering "SYSTEM RECORD DOCUMENTS " with white indelible ink. The access door shall be locked with a 3/4" barrel lock and the hinge shall be a solid width 12" stainless steel piano hinge. The enclosure will supply 4 mounting holes. Inside the enclosure will accommodate standard 8 1/2 x 11 manuals and loose document records that will be protected within the enclosure. A legend sheet will be permanently attached to the door for system required documentation, key contacts and system information. The SRD will have securely mounted inside a minimum of 4 Gigabyte digital flash memory drive with a standard USB B connector for uploading and downloading information. The drive shall not be accessible without tools to any person whom gains access to the records. The enclosure shall also provide 2 key ring holders with a location to mount standard business type cards for key contact personnel.

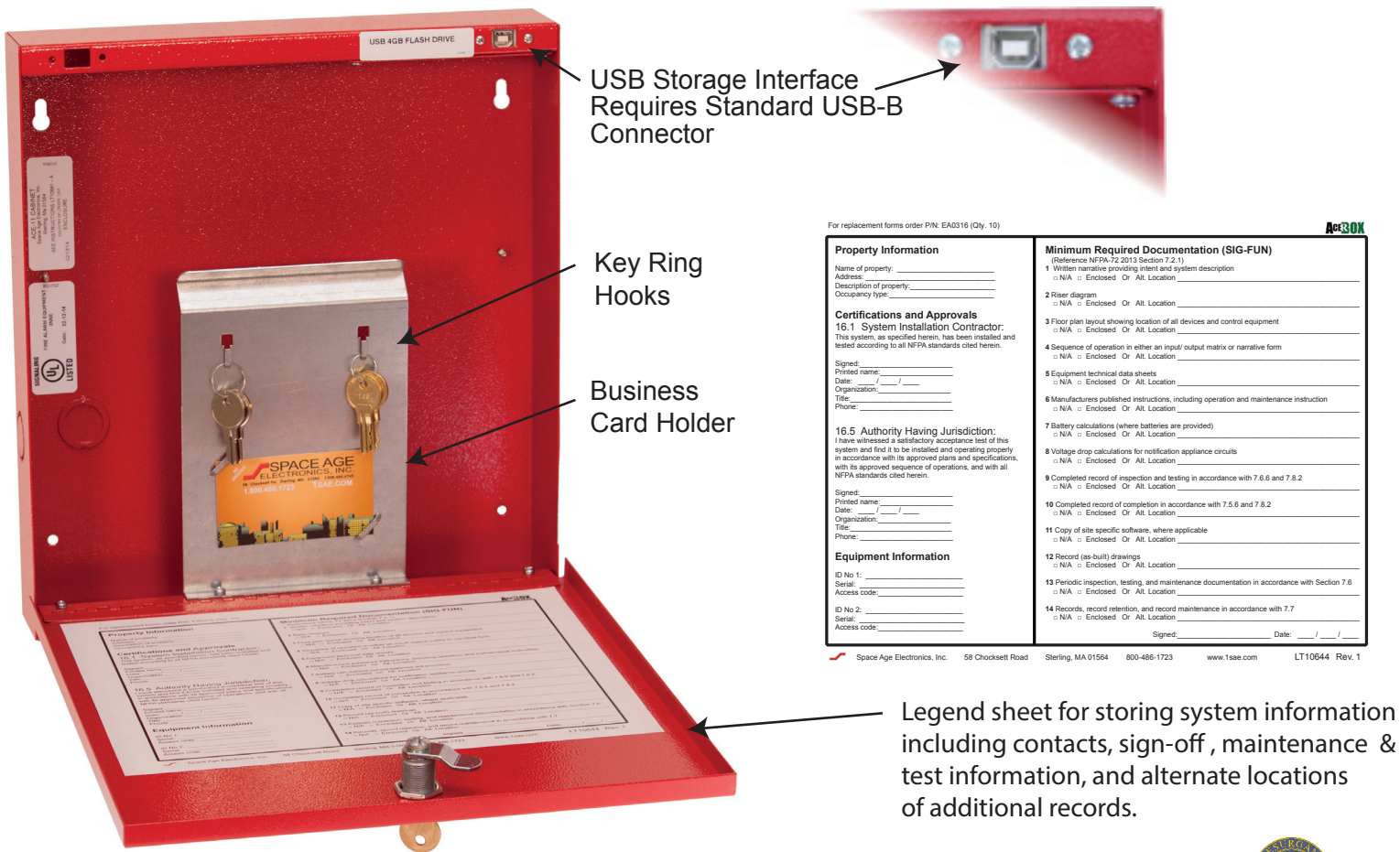

For replacement forms order PIN: EA0316 (Qty. 10)

Property Information	Minimum Required Documentation (SIG-FUN)
Name of property: _____	1 Written narrative providing intent and system description <input type="checkbox"/> N/A <input type="checkbox"/> Enclosed <input type="checkbox"/> All Location
Address: _____	2 Riser diagram <input type="checkbox"/> N/A <input type="checkbox"/> Enclosed <input type="checkbox"/> All Location
Description of property: _____	3 Floor plan layout showing location of all devices and control equipment <input type="checkbox"/> N/A <input type="checkbox"/> Enclosed <input type="checkbox"/> All Location
Occupancy type: _____	4 Sequence of operation in either an input/output matrix or narrative form <input type="checkbox"/> N/A <input type="checkbox"/> Enclosed <input type="checkbox"/> All Location
Certifications and Approvals	
16.1 System Installation Contractor: This system, as specified herein, has been installed and tested according to all NFPA standards cited herein.	
Signed: _____	5 Equipment technical data sheets <input type="checkbox"/> N/A <input type="checkbox"/> Enclosed <input type="checkbox"/> All Location
Printed name: _____	6 Manufacturers published instructions, including operation and maintenance instruction <input type="checkbox"/> N/A <input type="checkbox"/> Enclosed <input type="checkbox"/> All Location
Date: ____/____/____	7 Battery calculations (where batteries are provided) <input type="checkbox"/> N/A <input type="checkbox"/> Enclosed <input type="checkbox"/> All Location
Organization: _____	8 Voltage drop calculations for notification appliance circuits <input type="checkbox"/> N/A <input type="checkbox"/> Enclosed <input type="checkbox"/> All Location
Title: _____	9 Completed record of inspection and testing in accordance with 7.6.6 and 7.8.2 <input type="checkbox"/> N/A <input type="checkbox"/> Enclosed <input type="checkbox"/> All Location
Phone: _____	10 Completed record of completion in accordance with 7.5.6 and 7.8.2 <input type="checkbox"/> N/A <input type="checkbox"/> Enclosed <input type="checkbox"/> All Location
16.5 Authority Having Jurisdiction: I have witnessed a satisfactory acceptance test of this system and find it to be installed and operating properly in accordance with its approved plans and specifications, with its approved sequence of operations, and with all NFPA standards cited herein.	
Signed: _____	11 Copy of site specific software, where applicable <input type="checkbox"/> N/A <input type="checkbox"/> Enclosed <input type="checkbox"/> All Location
Printed name: _____	12 Record (as-built) drawings <input type="checkbox"/> N/A <input type="checkbox"/> Enclosed <input type="checkbox"/> All Location
Date: ____/____/____	13 Periodic inspection, testing, and maintenance documentation in accordance with Section 7.6 <input type="checkbox"/> N/A <input type="checkbox"/> Enclosed <input type="checkbox"/> All Location
Organization: _____	14 Records, record retention, and record maintenance in accordance with 7.7 <input type="checkbox"/> N/A <input type="checkbox"/> Enclosed <input type="checkbox"/> All Location
Title: _____	Signed: _____ Date: ____/____/____
Phone: _____	
Equipment Information	
ID No 1: _____	
Serial: _____	
Access code: _____	
ID No 2: _____	
Serial: _____	
Access code: _____	

Space Age Electronics, Inc. 58 Chocksett Road Sterling, MA 01564 800-486-1723 www.1sae.com LT10644 Rev. 1

Ordering Information:

Part #	Description
SSU00689	System Record Documents Cabinet RED
SSU00690	Custom screening with your Logo
EA0315	10 pack door legend sheet



Reviewed for Code Compliance
Permitting and Inspections
Department
02/10/2020



Space Age Electronics, Inc.
www.1sae.com
800.486.1723 Toll Free
508.485.0966 Local
508.485.4740 Fax

This document is subject to change without notice, see doc # ED0479 for legal disclaimer

Recessed Mount
with Face Flange



Surface Mount

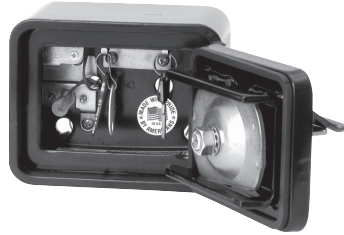

High Security Industrial/Government Key Box



The number one high-security KNOX-BOX® is used for most commercial applications including businesses, schools, government and public buildings, community associations and apartment complexes. The 3200 Series KNOX-BOX holds keys, access cards and other small items necessary for emergency access.

The hinged-door 3200 Series KNOX-BOX is more convenient than the lift-off door version because it allows single-handed operation and opened or closed, it's all one unit.

Features and Benefits

- Holds up to 10 keys and access cards in interior compartment
- Ensures high security. Box and lock are UL® Listed
- Includes a Knox-Coat® proprietary finishing process that protects Knox products up to four times better than standard powder coat
- Resists moist conditions with a weather resistant door gasket
- Hinged door allows single-handed operation
- Colors: Black, Dark Bronze or Aluminum
- Weight: Surface mount - 8 lbs.
Recessed mount - 9 lbs.

Options

- Alarm tamper switches (UL Listed)
- Recessed Mounting Kit (RMK) for recessed models only
- Inside switch for use on electrical doors, gates and other electrical equipment

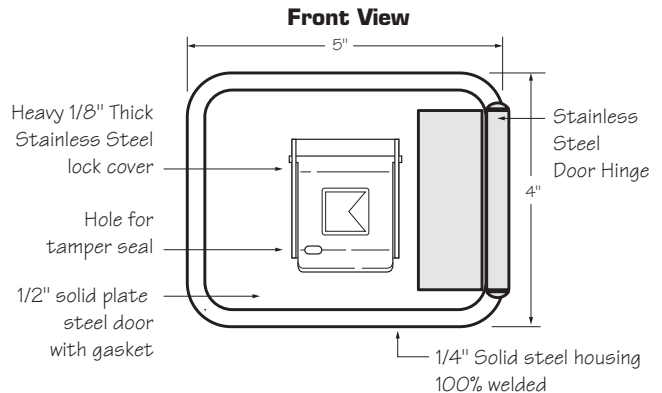

3200 Surface Mount

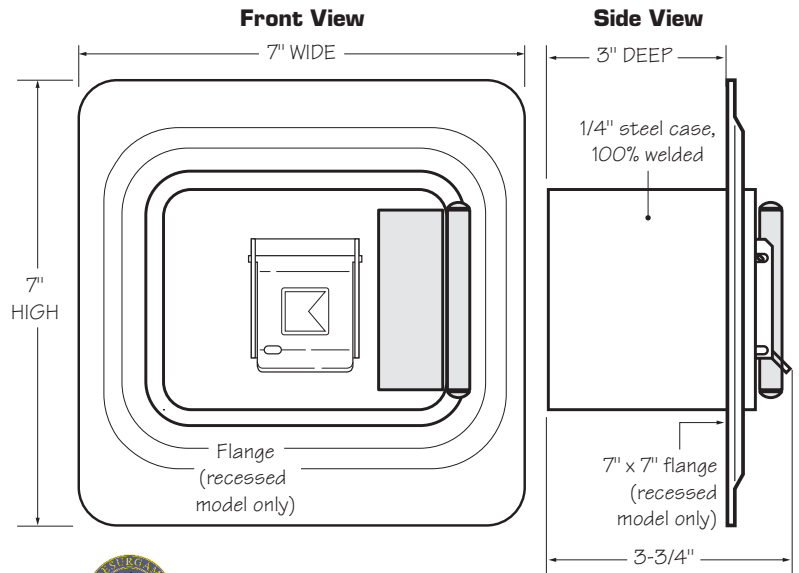

3200 Recessed Mount



Reviewed for Code Compliance
Permitting and Inspections
Department
Approved 02/10/2020

Ordering Specifications

To insure procurement and delivery of the 3200 Series KNOX-BOX, it is suggested that the following specification paragraph be used:

KNOX-BOX surface/recessed mount with hinged door, with/without UL Listed tamper switches. 1/4" plate steel housing, 1/2" thick steel door with interior gasket seal and stainless steel door hinge. Box and lock UL Listed. Lock has 1/8" thick stainless steel dust cover with tamper seal mounting capability.

Exterior Dimensions: Surface mount body- 4"H x 5"W x 3-3/4"D
Recessed mount flange- 7"H x 7"W

Lock: UL Listed. Double-action rotating tumblers and hardened steel pins accessed by a biased cut key.

Finish: Knox-Coat® proprietary finishing process

Colors: Black, Dark Bronze or Aluminum

P/N: 3200 Series KNOX-BOX (mfr's cat. ID)

Mfr's Name: **KNOX COMPANY**

**Suggested minimum mounting height
6 feet above ground**

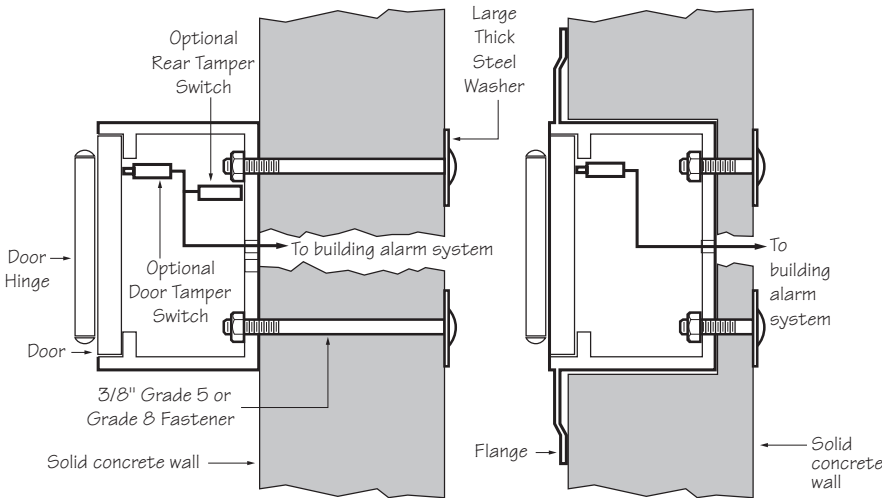

**3200 Series Hinged Door
Surface Mount**

**3200 Series Hinged Door
Recess Mount**

Inside View

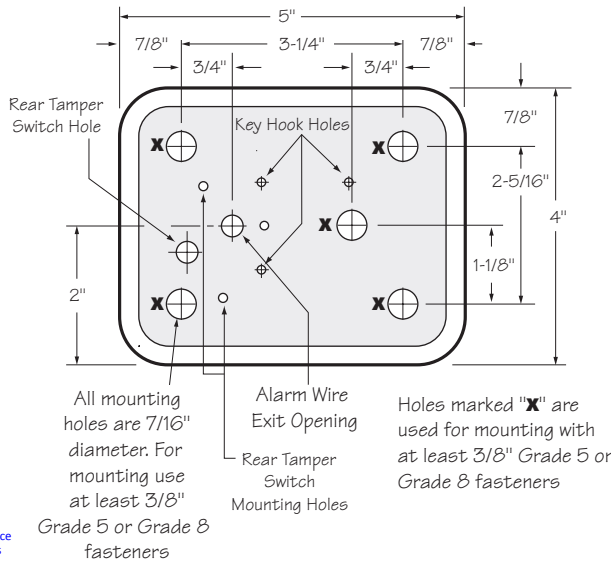

Attention: KNOX-BOX® is a very strong device that MUST be mounted properly to ensure maximum security and resist physical attack.

Knox® Rapid Entry System

The Knox Company manufactures a complete line of high security products including Knox-Box key boxes, key vaults, cabinets, key switches, padlocks, locking FDC caps, plugs and electronic master key security systems. For more information or technical assistance, please call Customer Service at 1-800-552-5669.

Recessed Mounting Kit

The 3200 Recessed Mounting Kit (RMK) is used for recessed models only. It contains a shell housing and mounting hardware to be cast-in-place in new concrete or masonry construction. After construction is completed, the KNOX-BOX mounts inside the RMK. The RMK may only be used in new concrete or masonry construction.

Installation In Cast Concrete

The optional Recessed Mounting Kit is for use in new concrete or masonry construction only. The kit includes a shell housing and mounting hardware to be cast-in-place. The KNOX-BOX is mounted into the shell housing after construction is completed.

Dimensions

Rough-in Dimensions: 6-1/2"H x 6-1/2"W x 5"D

IMPORTANT: Care should be taken to insure that the front of the RMK shell housing, including the cover plate and screw heads, is flush with the finish wall. The RMK must be plumbed to insure vertical alignment of the vault.

Recessed Mounting Using Recessed Mounting Kit (RMK)

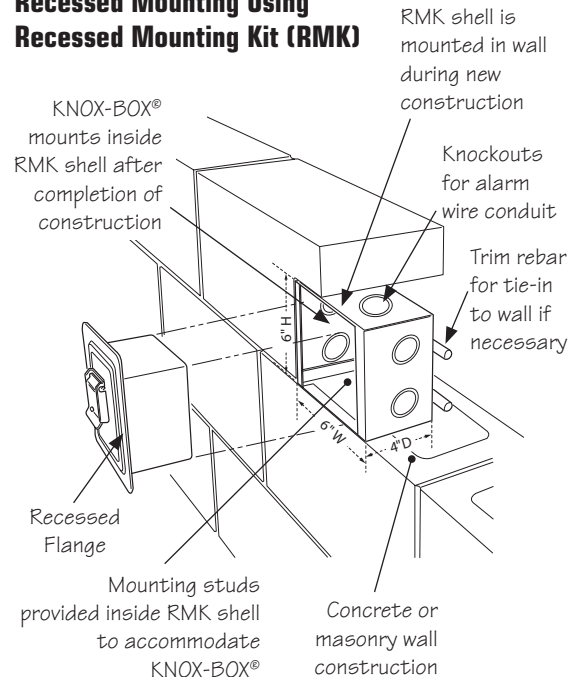

NOTIFICATION APPLIANCE CIRCUIT VOLTAGE DROPS

Immucell

Portland, Maine

PANEL	CIRCUIT	WIRE GAUGE	LENGTH	CURRENT DRAW	VOLTAGE DROP		VOLTAGE LOSS	END VOLTAGE @ 24.0VDC		END VOLTAGE @ 20.4VDC		CIRCUIT LOAD
						VDC		VDC	VDC	VDC		
FACP	NAC 1	14	400 FT	0.886A	1.79	VDC	7.46%	22.21	VDC	18.61	VDC	35%
FACP	NAC 2	14	515 FT	0.63A	1.64	VDC	6.83%	22.36	VDC	18.76	VDC	25%
FACP	NAC 3	14	335 FT	0.486A	0.82	VDC	3.43%	23.18	VDC	19.58	VDC	19%

Calculated @ Maximum Distance/Current



Reviewed for Code Compliance
Permitting and Inspections
Department
Approved: 02/10/2020



NFW-100X - AC Branch Current

Select devices using the "Qty" column.
Use yellow cells to enter quantities and current values.
To show only selected devices, select "Show Selected Devices".
To clear selected devices, select "Clear Selections".

Note: These selections only determine the AC branch current. If these devices will affect the battery requirements, you need to select them on the System Current Draw sheet.

120 VAC 220/240 VAC

Device	Qty		Current	Total
NFW-100X	1	x	3.20 A	3.20 A
CHG-75	0	x	2.05 A	
CHG-120	0	x	2.00 A	
APS-6R	0	x	2.50 A	
APS2-6R	0	x	2.90 A	
FCPS-24S	0	x	3.20 A	
ACPS-610	0	x	5.00 A	
HPFF8	0	x	3.60 A	
HPFF12	0	x	5.00 A	
[]	0	x	0.00 A	
[]	0	x	0.00 A	
			AC Branch Required:	3.20 A



System Power Requirements

NFW-100X Fire Alarm Control Panel

Protected Premises: <u>Immucell</u>	Date: <u>1/16/2020</u>
Address: <u>175 Industrial Way</u>	
City: <u>Portland</u> State: <u>Maine</u>	Zip: <u>04103</u>
Prepared By: <u>Norris Inc</u>	Phone: <u>1-800-370-3473</u>
Address: <u>2257 West Broadway</u>	Email: jbridges@norrisinc.com
City: <u>South Portland</u> State: <u>Maine</u>	Zip: <u>04107</u>

AC Branch Current Requirements 3.20 AMPS @ 120 VAC

Current required by source to power the fire alarm system.

Primary Standby Load 0.09 Amps

Current load on the primary power supply during non-alarm conditions.

Primary Alarm Load 2.93 Amps

Current load on the primary power supply during alarm conditions.

Secondary Load Requirements 6.93 Amp Hours

Total Secondary Load from the calculation table below.

Current Draw		Time (hours)	Total (AH)
Secondary Standby Load 0.229 A	x	Required Standby Time	
		24 hours	5.51
Secondary Alarm Load 3.184 A	x	Required Alarm Time (hours)	
		0.084 hours	0.27
Total Secondary Load			5.77
Derating factor			x 1.2
Secondary Load Requirements			6.93 AH

Battery Selection 12 Amp Hours

Select batteries from the list below.

12 AH BAT-12120 Battery (12 volt)

- Two Four (two 12VDC sets in parallel)



Battery Distribution Chart

Shows amp-hour distribution of your selections.

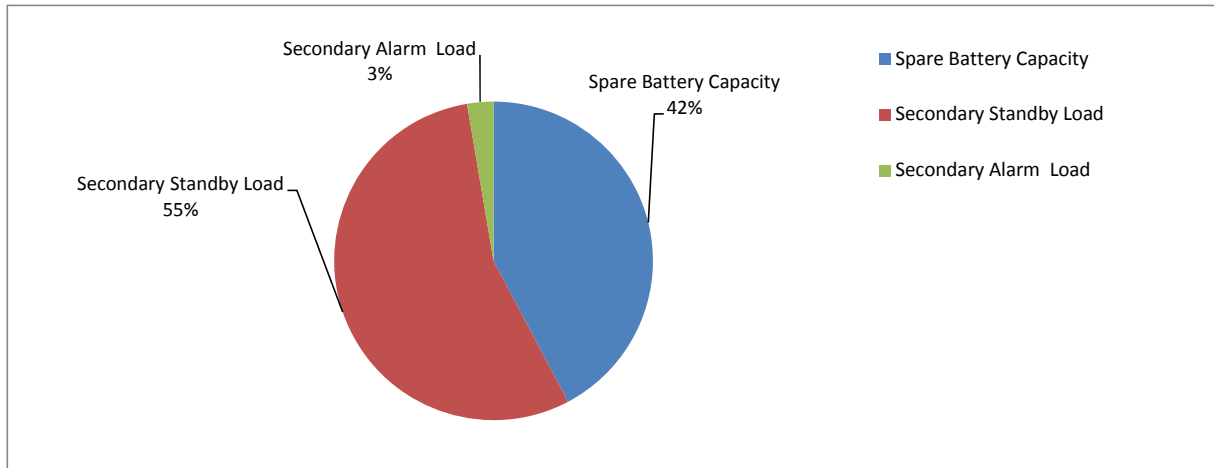

Comments

1. Batteries will fit in the FACP cabinet.
2. Selected battery size meets secondary load requirements.
3. The selected batteries (12AH) are within the charger range of this power supply (7-18AH).

Spare Battery Capacity	5.07	Battery Selection (AH) - Secondary Load Requirements (AH)
Secondary Standby Load	6.61	Secondary Standby Load (AH) * Derating Factor
Secondary Alarm Load	0.32	Secondary Alarm Load (AH) * Derating Factor



Reviewed for Code Compliance
Permitting and Inspections Department
Approved with Conditions
02/10/2020

FIRE ALARM SYSTEM MATRIX

SYSTEM INPUTS	CONTROL UNIT ACTIVATION								NOTIFICATION							
	A	B	C	D	E	F	G	H	I	J	K	L	M	N	O	P
1 MANUAL FIRE ALARM PULL STATION	•	•							•	•	•	•	•	•	•	•
2 AREA SMOKE DETECTOR	•	•							•	•	•	•	•	•	•	•
3 DUCT DETECTOR	•	•							•	•	•	•	•	•	•	•
4 CARBON MONOXIDE DETECTOR	•	•							•	•	•	•	•	•	•	•
5 SPRINKLER WATERFLOW - BUILDING	•	•							•	•	•	•	•	•	•	•
6 SPRINKLER TAMPER VALVE SUPERVISORY SWITCH	•	•							•	•	•	•	•	•	•	•
7 FIRE ALARM AC POWER FAILURE									•	•	•	•	•	•	•	•
8 FIRE ALARM SYSTEM LOW BATTERY									•	•	•	•	•	•	•	•
9 OPEN CIRCUIT									•	•	•	•	•	•	•	•
10 GROUND FAULT									•	•	•	•	•	•	•	•
11 NOTIFICATION APPLIANCE CIRCUIT SHORT									•	•	•	•	•	•	•	•

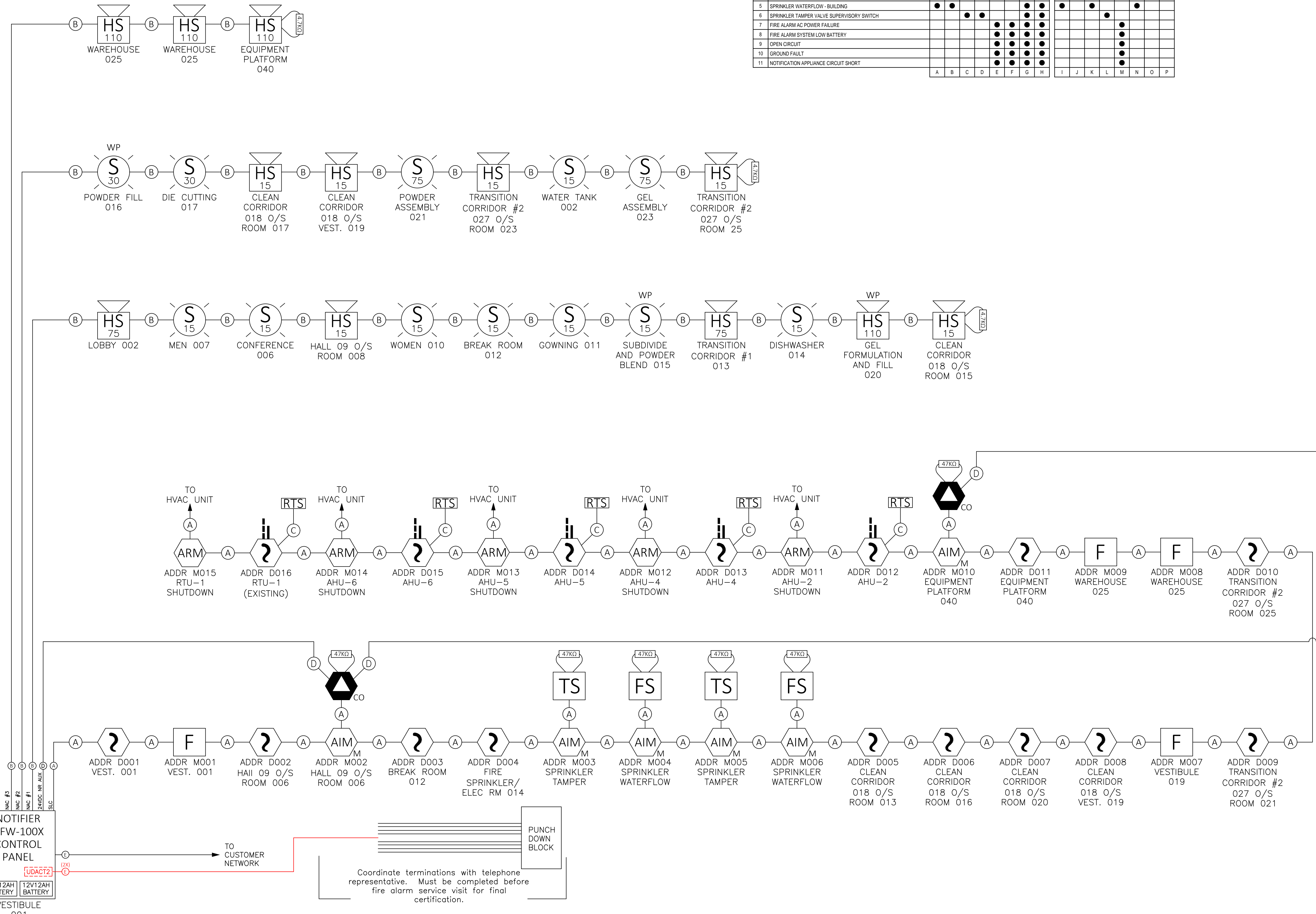

SYMBOL LEGEND

DEVICES	NOTIFICATION
PULL STATION	HORN STROBE
SMOKE DETECTOR	STROBE
CARBON MONOXIDE DETECTOR	XX = CANDELA RATING WP = WEATHERPROOF
DUCT DETECTOR	
REMOTE TEST STATION	
MONITOR MODULE (M=MINI)	
RELAY MODULE	

WIRE LEGEND

- 2 COND 16 AWG TWISTED PAIR FPL CABLE
- 2 COND 14 AWG FPL CABLE
- 3 COND 18 AWG TWISTED PAIR FPL CABLE
- 2 COND 18 AWG FPL CABLE
- CAT-6 CABLE

DEVICE ADDRESSES:

EACH DEVICE MUST BE LABELED WITH THE NODE, LOOP AND SLC ADDRESS.
DEVICE EXAMPLE: N1L1D001 MODULE EXAMPLE: N1L1M001
CARBON MONOXIDE DETECTORS MUST BE LABELED WITH THE MANUFACTURERS REPLACEMENT DATE.
IMPORTANT! DUPLICATE ADDRESSES BETWEEN DEVICES AND MODULES ARE NOT AN ERROR. NOTE: PULL STATIONS ARE IDENTIFIED AS MODULES BY THE FIRE ALARM CONTROL PANEL.

INSTALLATION NOTES:

ALL FIELD WIRING SHALL BE INSTALLED IN CONDUIT.
FIELD WIRING SHALL BE INSTALLED FOLLOWING THE CURRENT EDITION OF NFPA 70: NATIONAL ELECTRIC CODE(2017), ALL APPLICABLE MUNICIPAL, COUNTY, & STATE CODES, REQUIREMENTS, AND REGULATIONS, AS WELL AS ALL MANUFACTURER GUIDELINES FOR INSTALLATION.
CONTROL PANELS, DEVICES, AND ALL OTHER SYSTEM COMPONENTS SHALL BE INSTALLED FOLLOWING THE CURRENT EDITION OF NFPA 72: NATIONAL FIRE ALARM AND SIGNALING CODE(2019), ALL APPLICABLE MUNICIPAL, COUNTY, & STATE CODES, REQUIREMENTS, AND REGULATIONS, AS WELL AS ALL MANUFACTURER GUIDELINES FOR INSTALLATION.
THE INSTALLER SHALL FOLLOW CORRECT CONDUCTOR POLARITY, INDICATED CIRCUIT DIVISIONS, PROPER GROUNDING AND SHIELDING WITHOUT EXCEPTION. IMPROPER INSTALLATION CAN RESULT IN INTERFERENCE, TRANSIENT VOLTAGE, OR SHORT CIRCUITS CAUSING UNDESIRABLE OPERATION OR DAMAGE TO THE CONTROL PANEL, DEVICES AND ANY OTHER INTEGRATED COMPONENTS.
IF EXCEEDING 4500 FEET, THE GAUGE OF WIRE USED FOR THE SLC LOOP (IDENTIFIED AS "A" ON THIS PRINT), SHALL BE DETERMINED BY THE INSTALLER FOLLOWING GUIDELINES AND LIMITATIONS SET FORTH BY THE MANUFACTURER (NOTIFIER DOCUMENT #51253, INTELLIGENT CONTROL PANEL SLC WIRING MANUAL). THE SLC WIRING RISER IS SHOWN DIAGRAMMATICALLY ONLY TO ALLOW FOR VARIANCES IN ACTUAL WIRE DISTANCE, DEVICE PLACEMENT AND STRUCTURAL OR ENVIRONMENTAL REQUIREMENTS.
WIRE FOR THE NOTIFICATION APPLIANCE CIRCUITS (IDENTIFIED AS "B" ON THIS PRINT), SHALL FOLLOW THE SPECIFIC REQUIREMENTS OF THE WIRING LEGEND.
THIS SYSTEM MEETS NFPA REQUIREMENTS FOR OPERATION AT 32-120°F AND A RELATIVE HUMIDITY OF 91-95% AT 87-89°F. HOWEVER, THE USEFUL LIFE OF THE SYSTEMS STANDBY BATTERIES AND THE ELECTRONIC COMPONENTS MAY BE ADVERSELY AFFECTED BY EXTREME TEMPERATURE RANGES AND HUMIDITY. THEREFORE, IT IS RECOMMENDED THAT THIS SYSTEM AND ITS PERIPHERALS BE INSTALLED IN AN ENVIRONMENT WITH A NORMAL ROOM TEMPERATURE OF 60-80°F.

DESIGN NOTES:

SYSTEM DESIGN PERFORMANCE AND COMPLIANCE WITH ALL APPLICABLE CODES AND REQUIREMENTS IS THE RESPONSIBILITY OF THE DESIGNING ENGINEER. PROPER INSTALLATION OF THIS SYSTEM AND ITS COMPONENTS IS THE RESPONSIBILITY OF THE INSTALLING CONTRACTOR. ANY ALTERATIONS, CHANGES, OR DEFICIENCIES MUST BE BROUGHT TO THE ATTENTION OF THE DESIGNING ENGINEER.
NORRIS INC. ASSUMES NO RESPONSIBILITY FOR ERRORS IN SYSTEM DESIGN OR INSTALLATION, AS WELL AS ANY COSTS ASSOCIATED WITH CORRECTING THESE ERRORS, IF ANY EXIST, UNLESS SYSTEM DESIGN OR INSTALLATION WAS PERFORMED BY NORRIS INC.

RELAY & MONITOR MODULES:

CONNECTIONS FROM THE RELAY, AND MONITOR MODULES TO THE CONTROL EQUIPMENT, ALONG WITH ANY REQUIRED COMPONENTS SHALL BE FURNISHED BY THE INSTALLER.

REVISION 0: SUBMITTAL 01/16/2020

FIRE ALARM WIRING RISER

PROJECT NUMBER: 1551	SCALE: NONE
PROJECT:	DRAWN BY: JAB
IMMUCELL 175 INDUSTRIAL WAY PORTLAND, ME 04103	CHECKED BY: MP
	SHEET: FA-01



2257 BROADWAY SOUTH PORTLAND, MAINE