



HARRIMAN

AUBURN PORTLAND MANCHESTER

IMMUCELL CORPORATION ADDITION

PORTLAND, MAINE

Harriman Project No. 14326

Key Plan

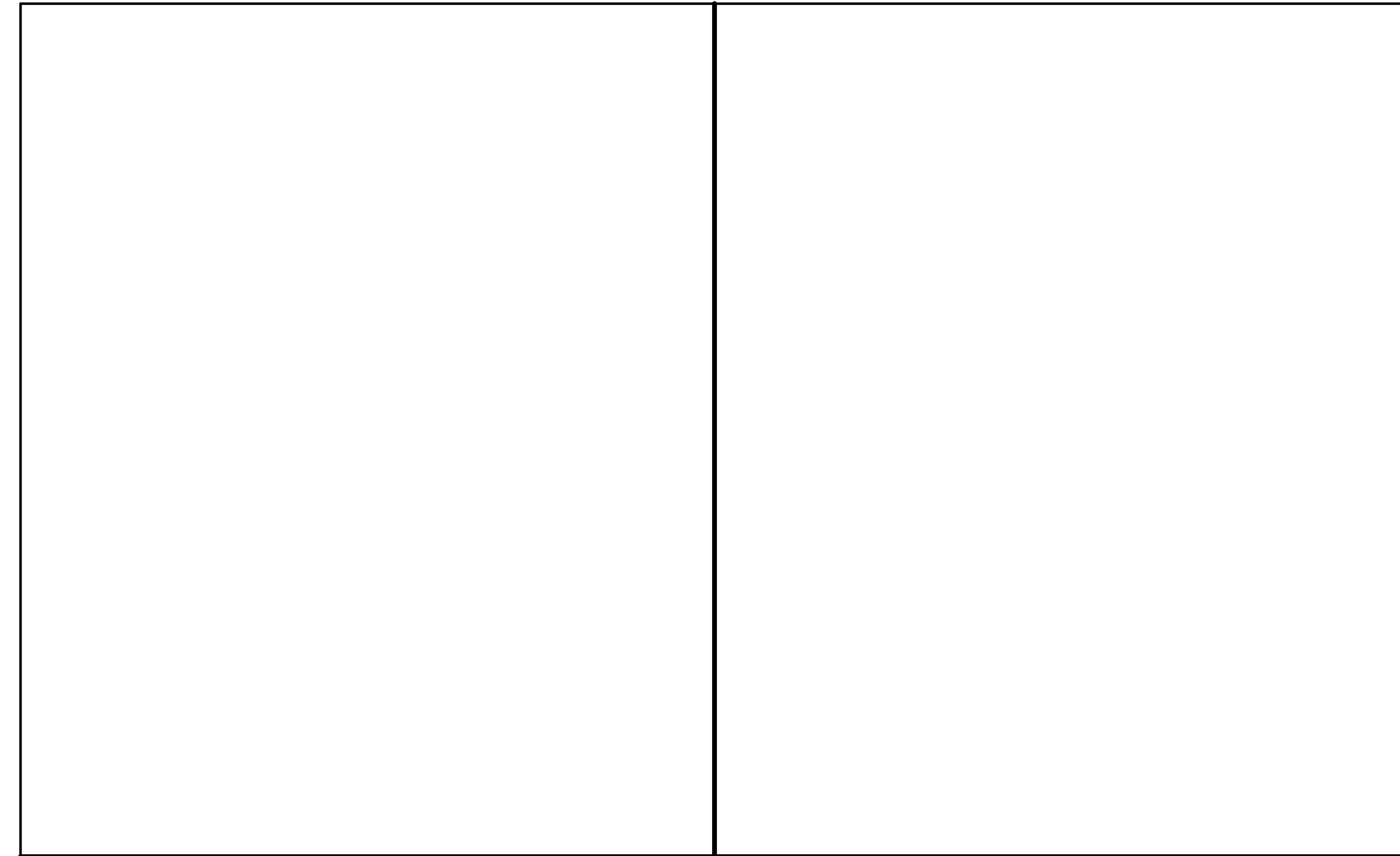

TREE STAKING DETAIL D3 NOT TO SCALE

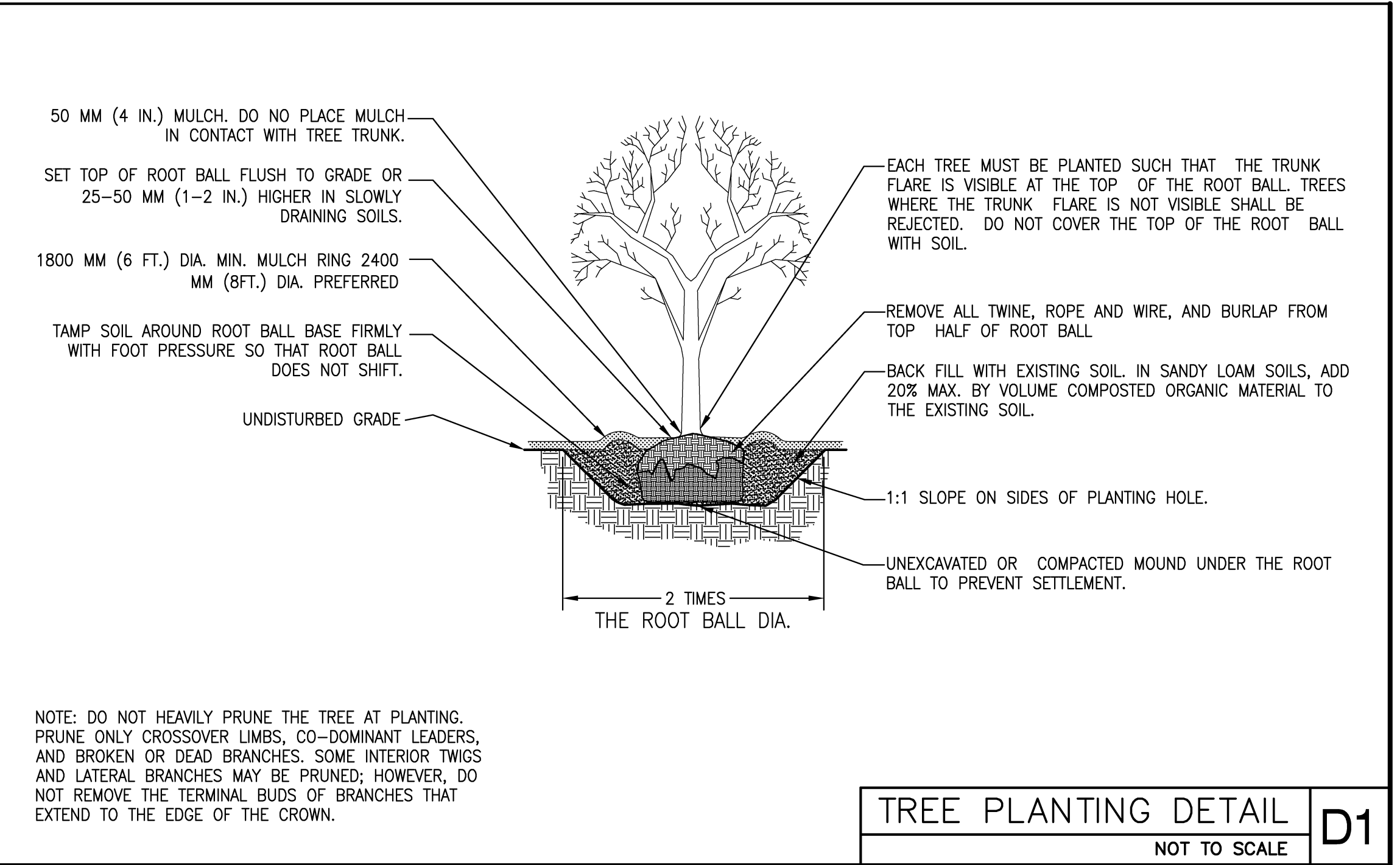

TREE PLANTING DETAIL D1 NOT TO SCALE

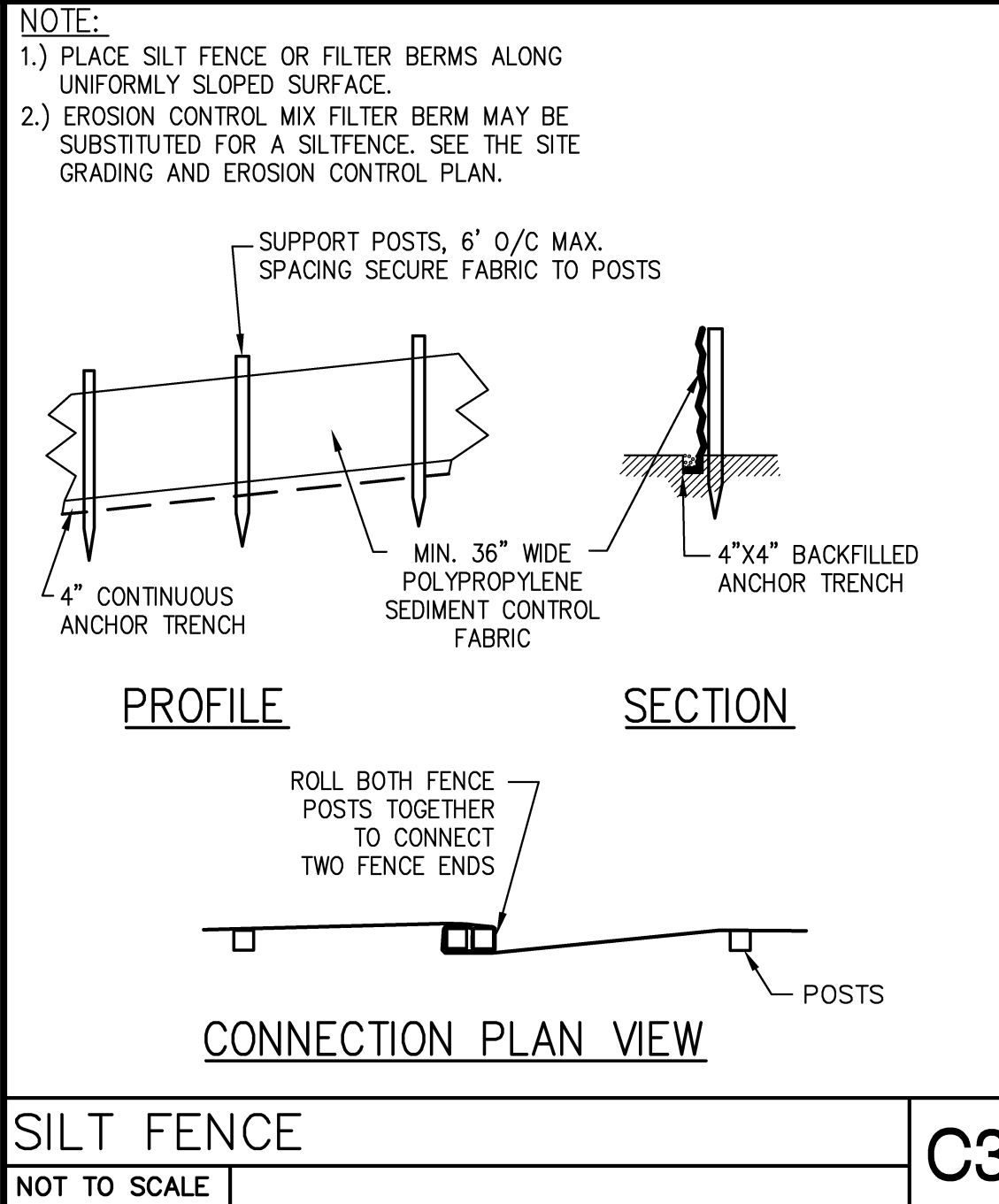
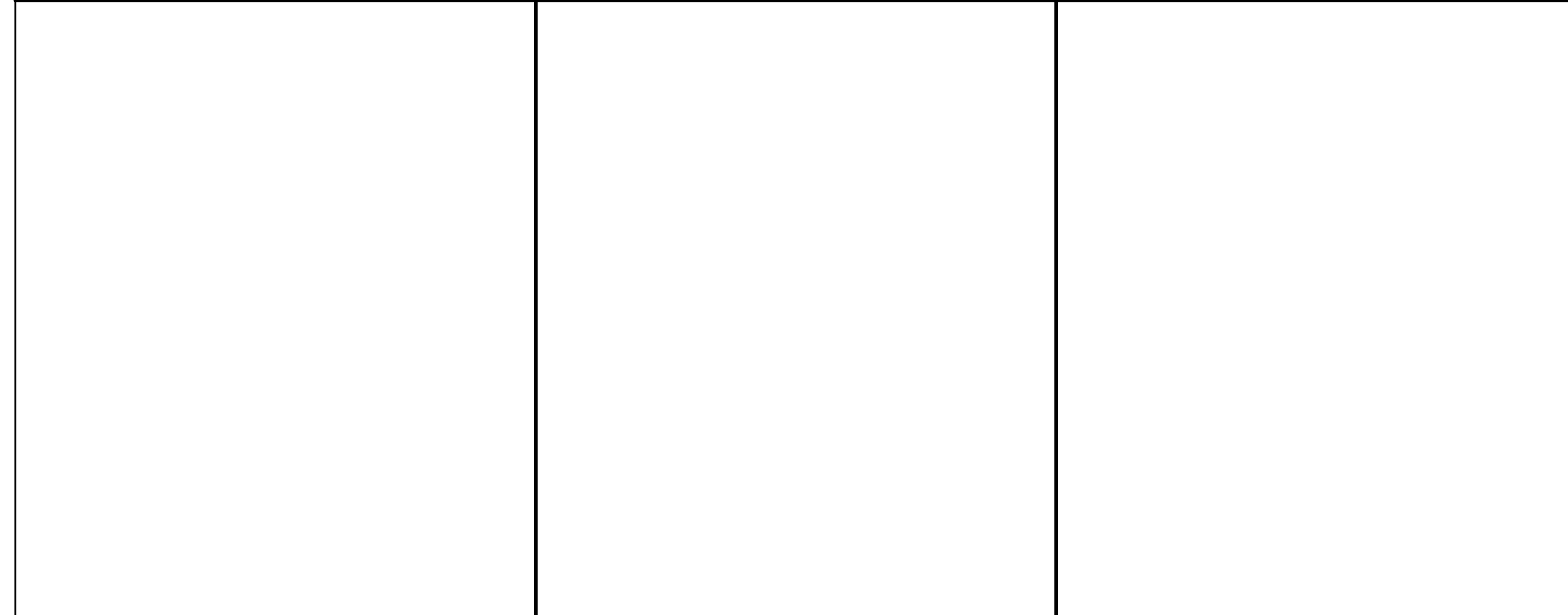

SILT FENCE C3 NOT TO SCALE

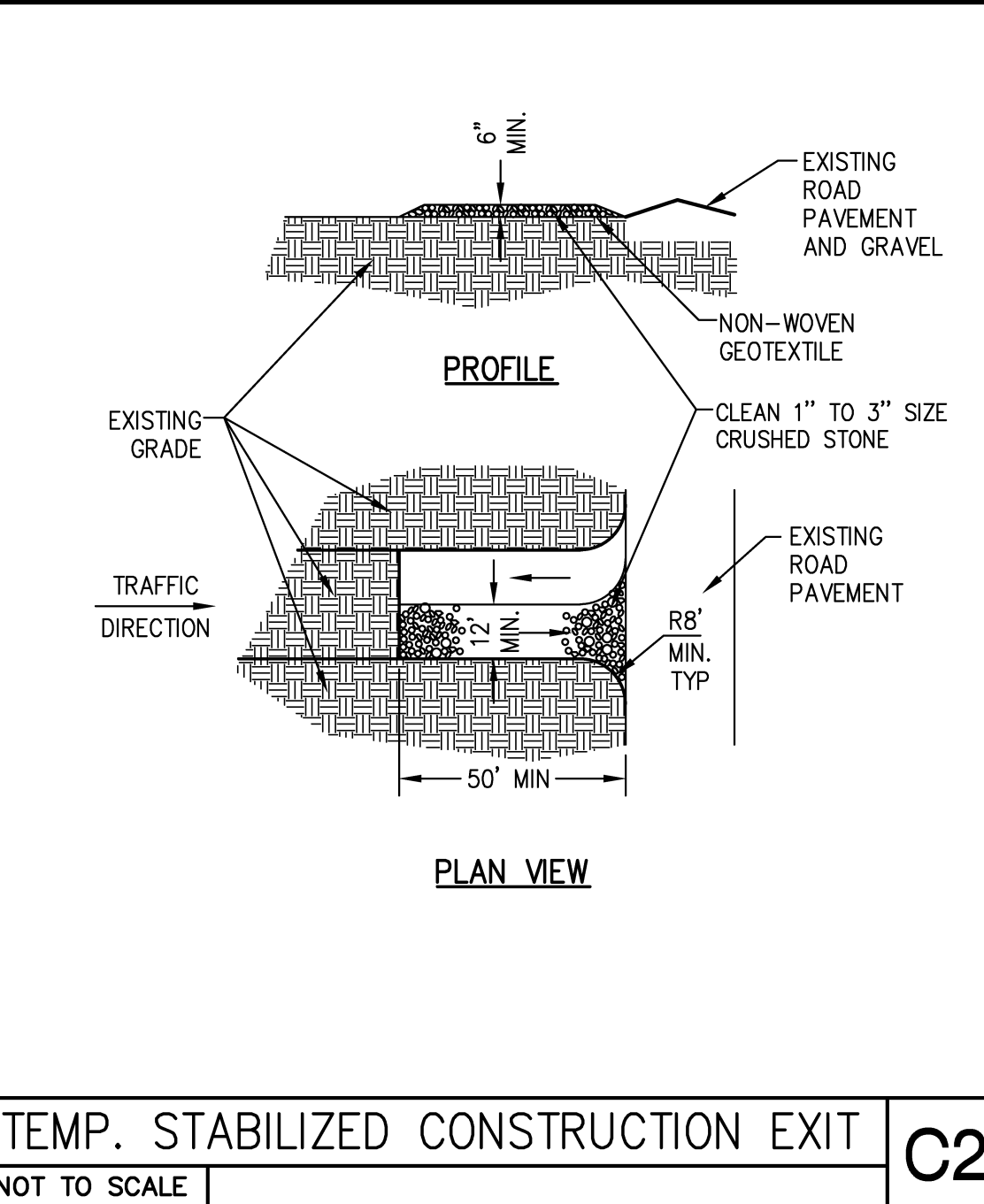

TEMP. STABILIZED CONSTRUCTION EXIT C2 NOT TO SCALE

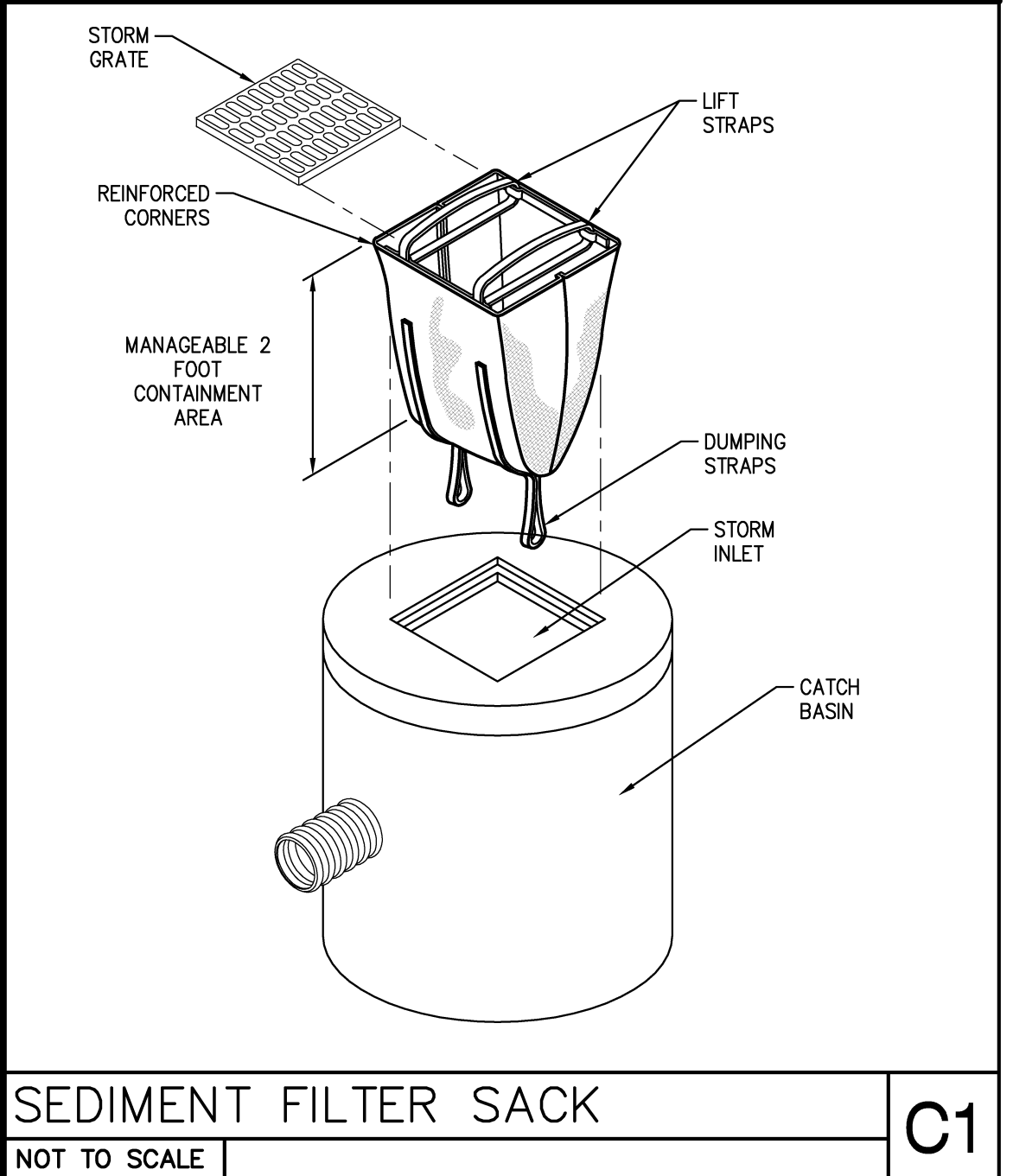

SEDIMENT FILTER SACK C1 NOT TO SCALE

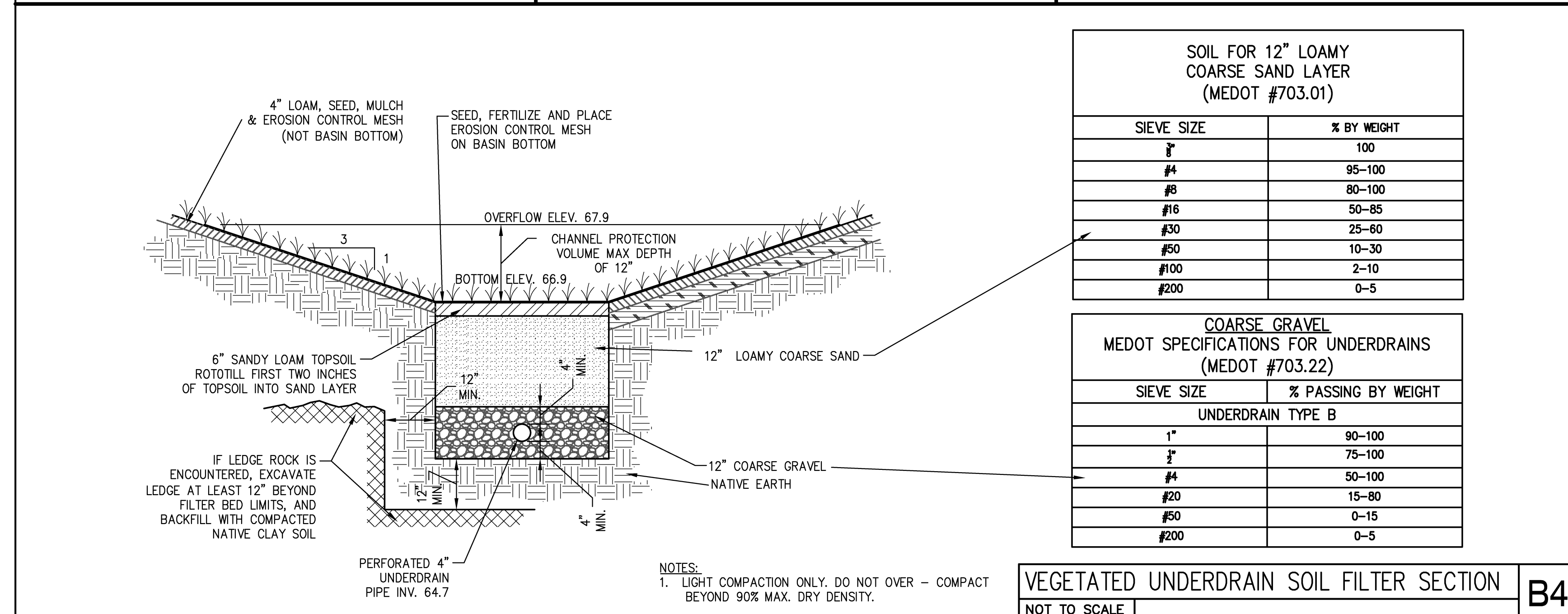

VEGETATED UNDERDRAIN SOIL FILTER SECTION B4 NOT TO SCALE

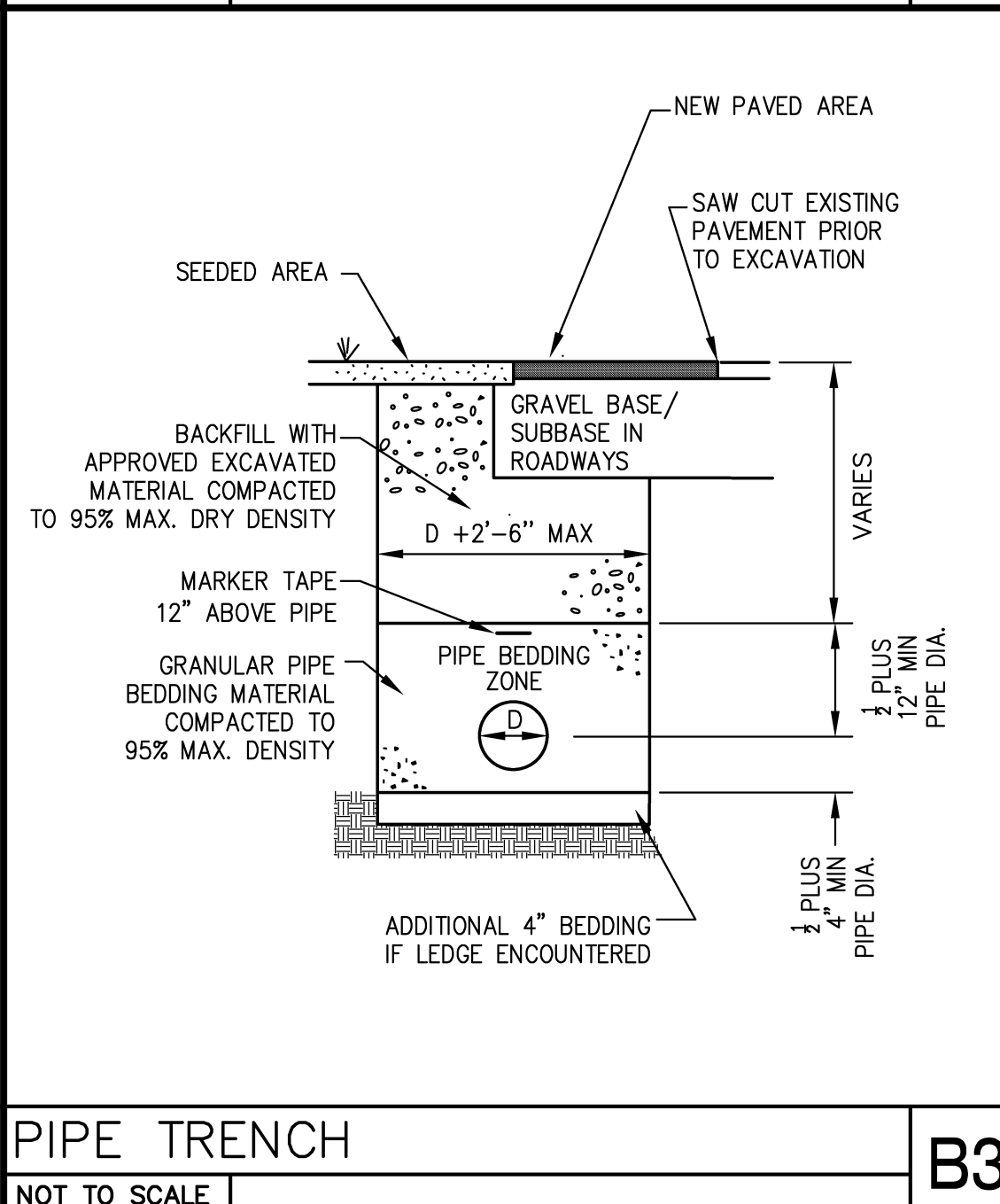

PIPE TRENCH B3 NOT TO SCALE

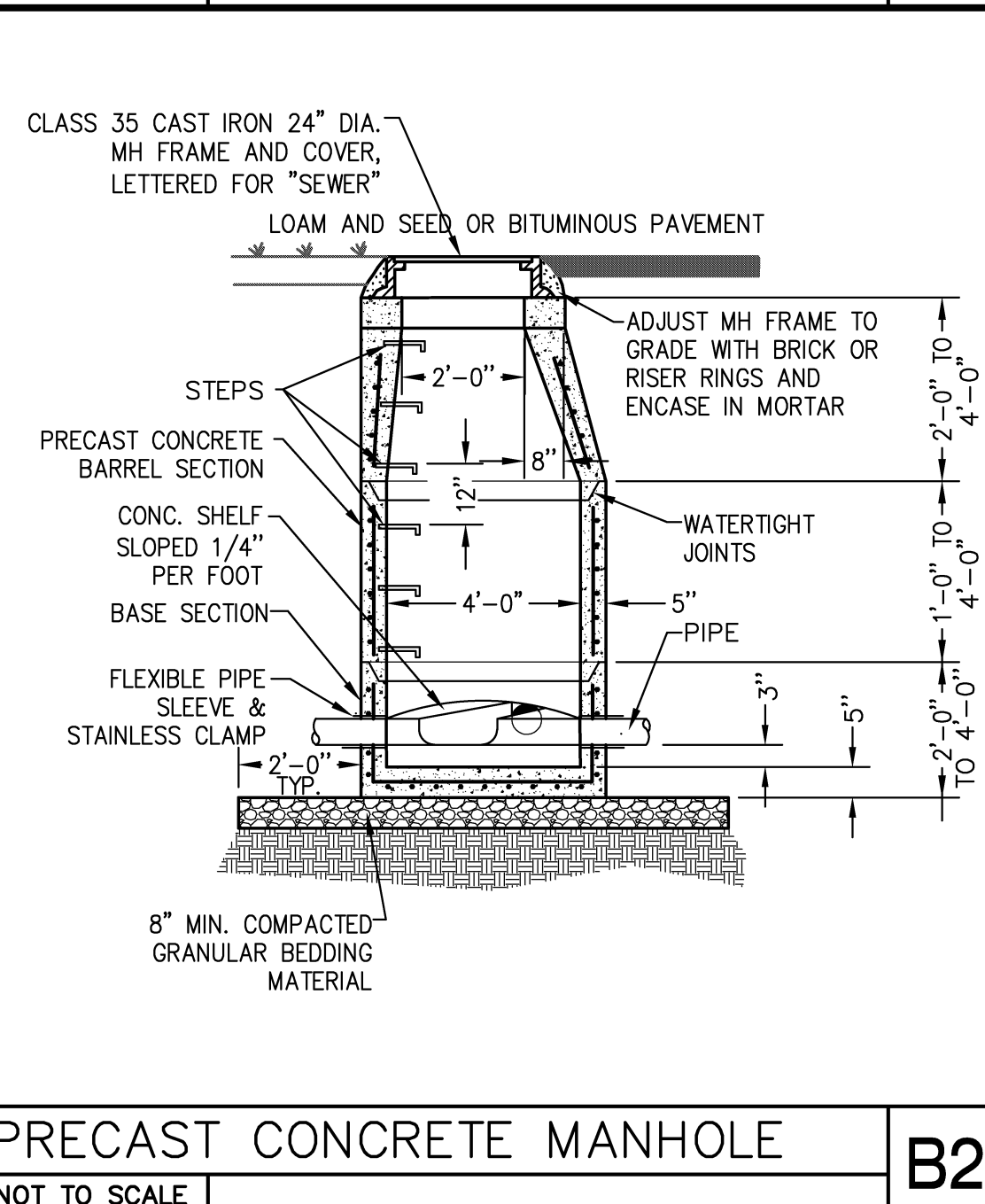

PRECAST CONCRETE MANHOLE B2 NOT TO SCALE

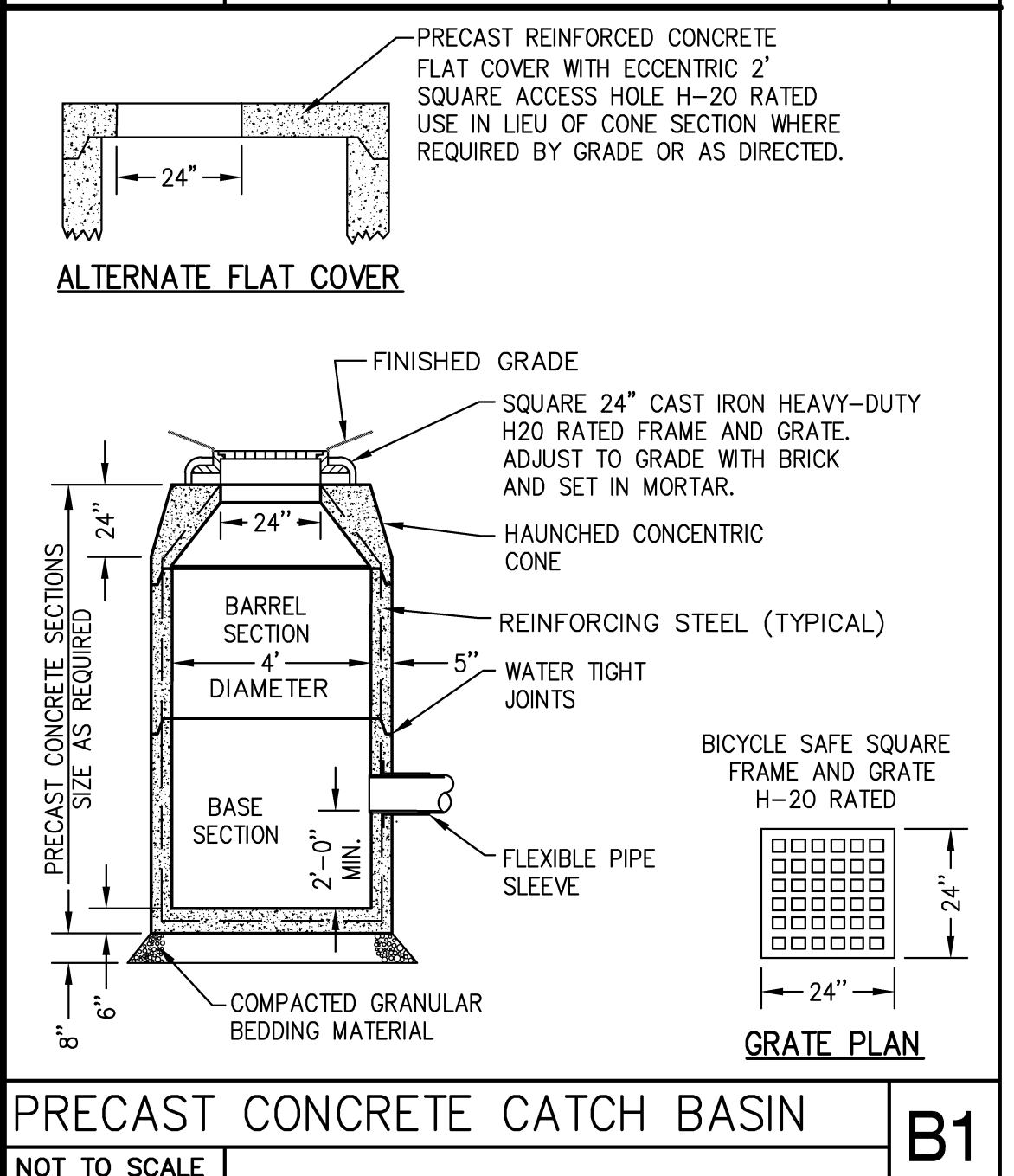

PRECAST CONCRETE CATCH BASIN B1 NOT TO SCALE

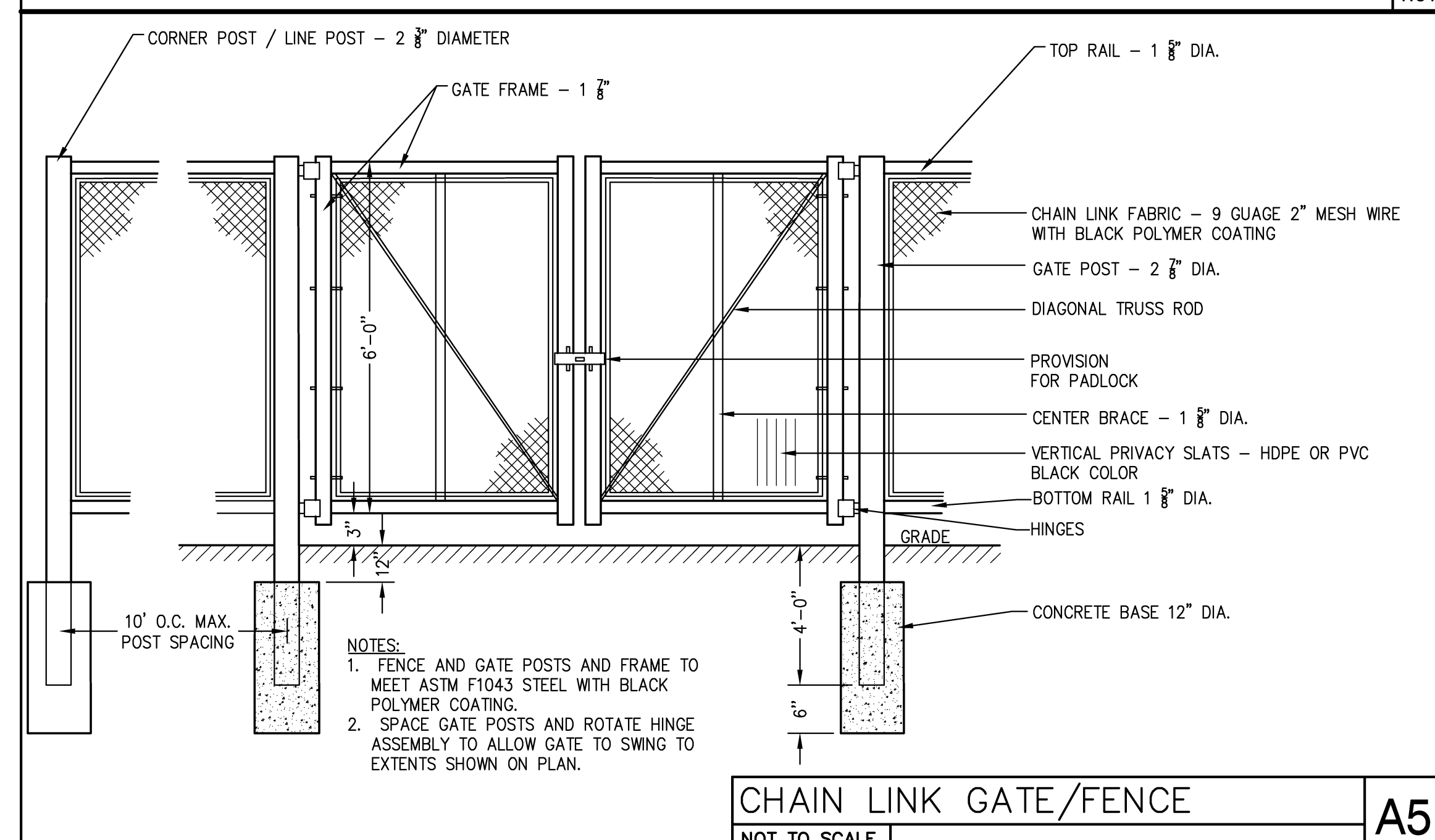

CHAIN LINK GATE/FENCE A5 NOT TO SCALE

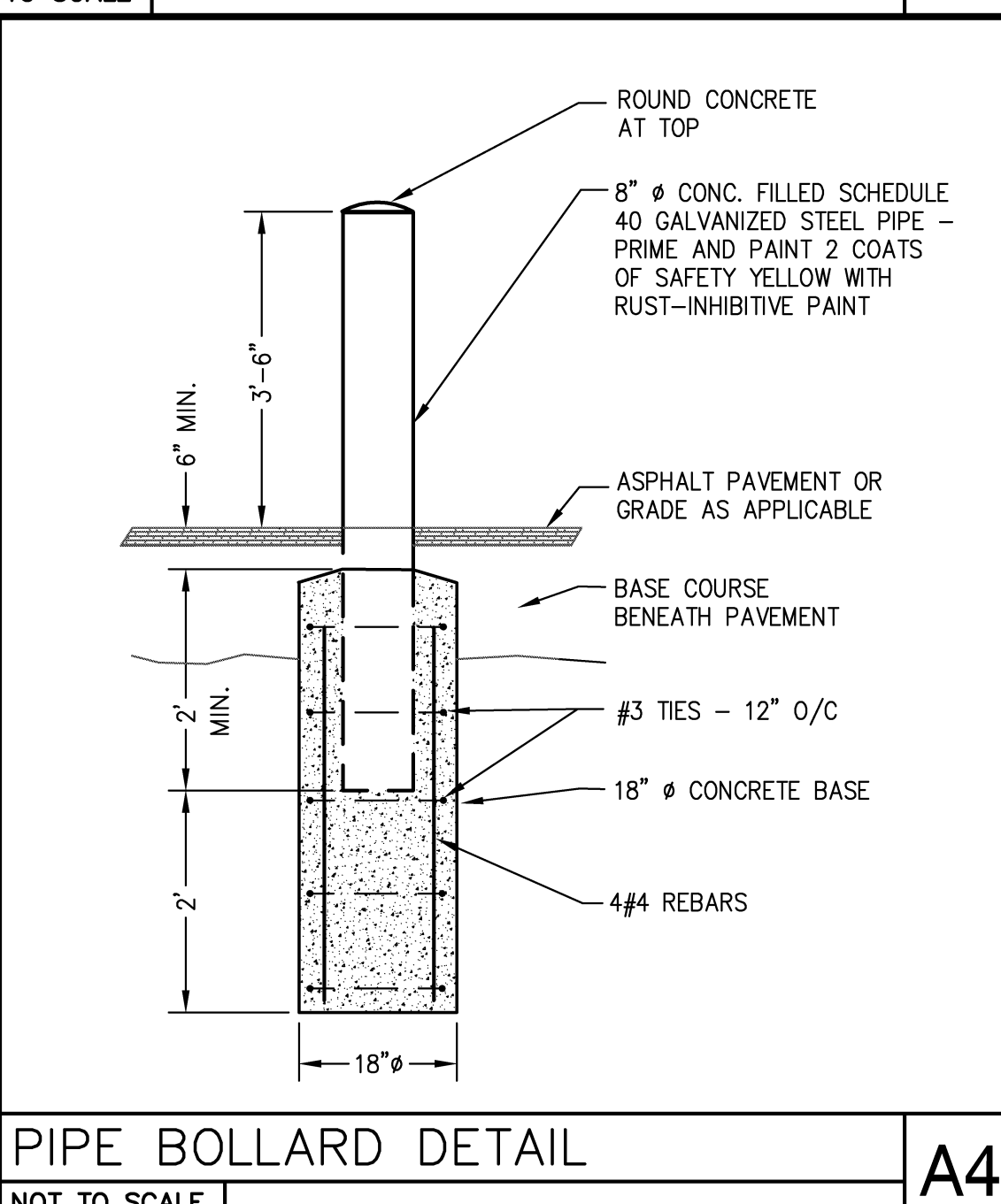

PIPE BOLLARD DETAIL A4 NOT TO SCALE

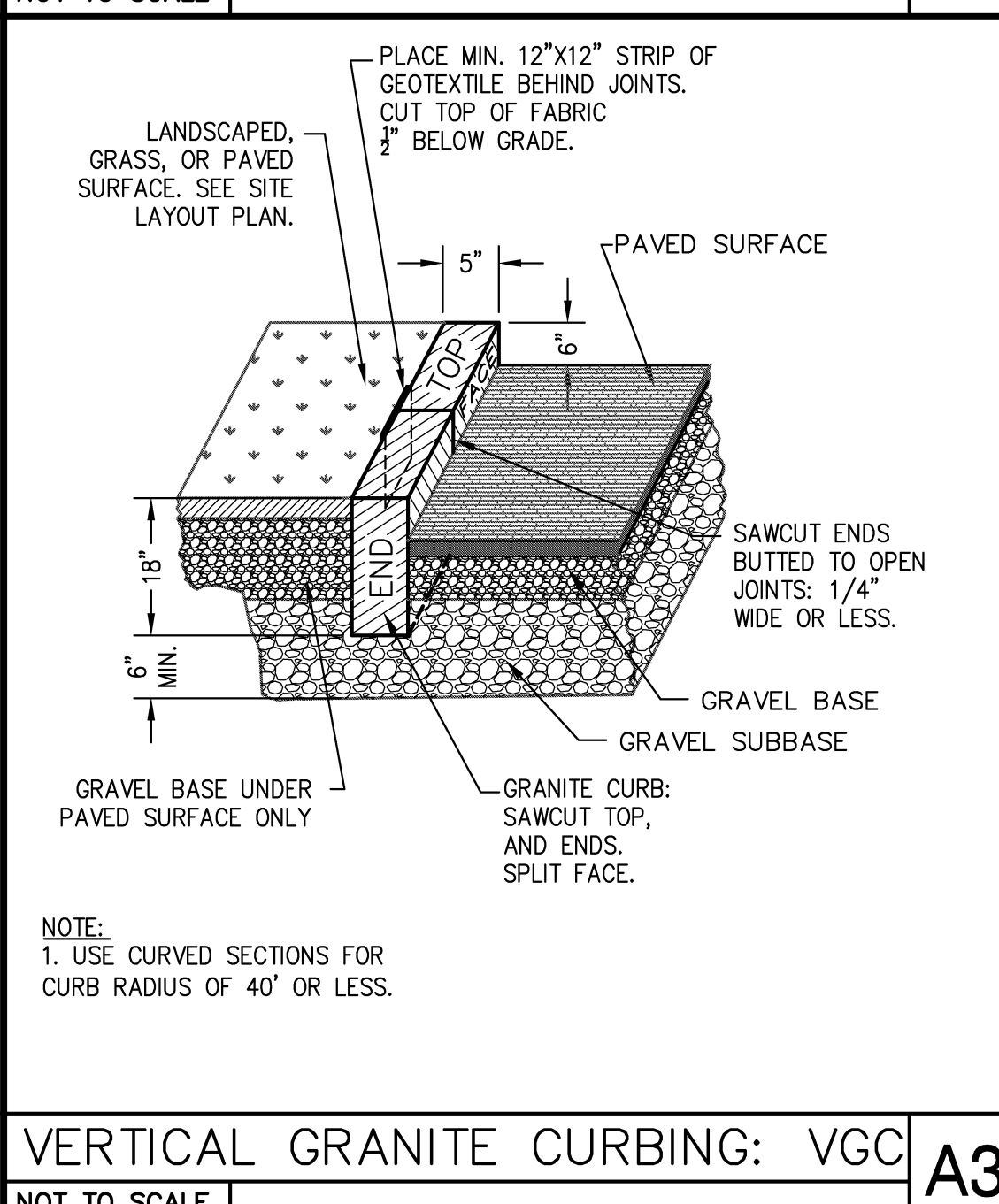

VERTICAL GRANITE CURBING: VGC A3 NOT TO SCALE

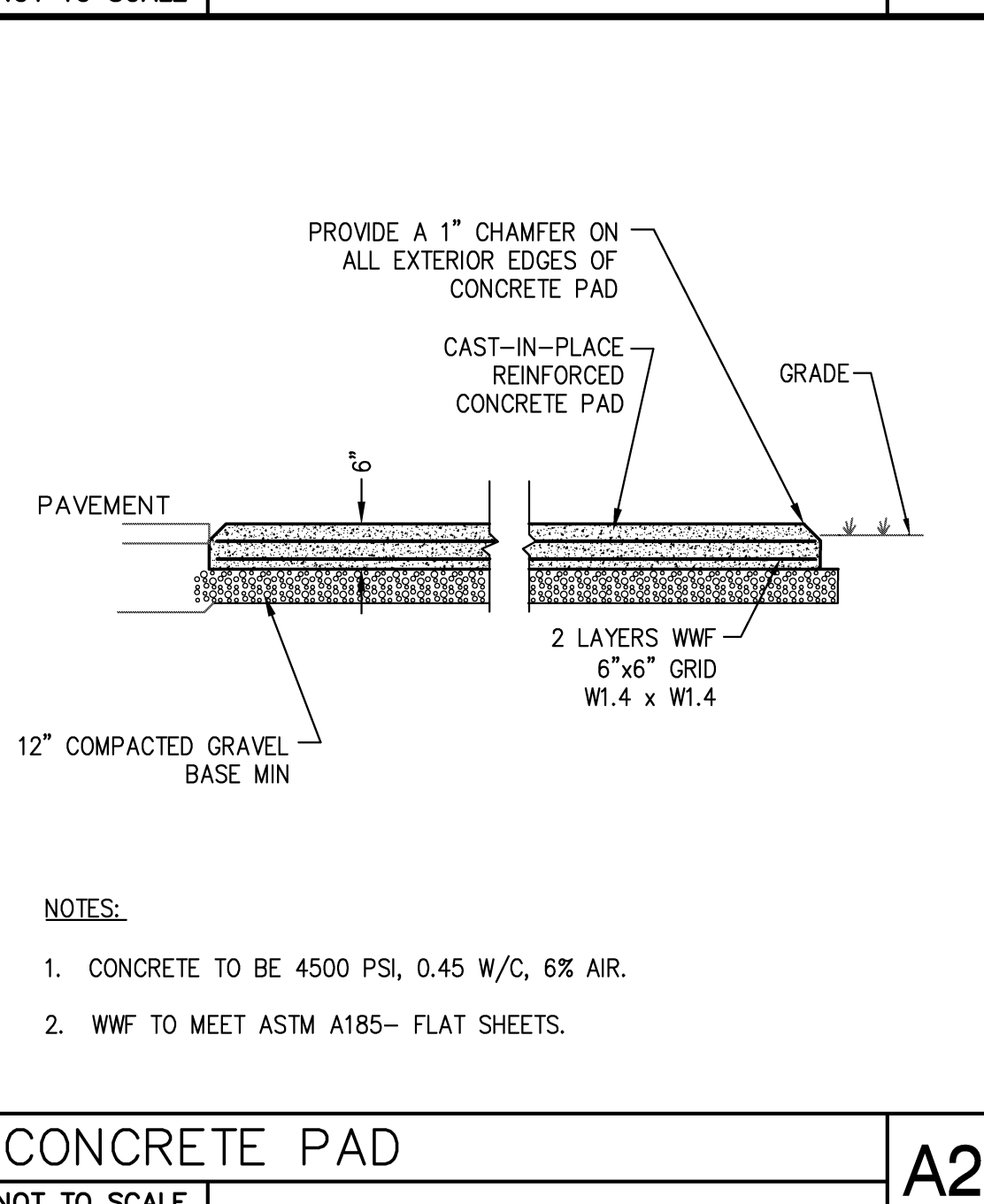

CONCRETE PAD A2 NOT TO SCALE

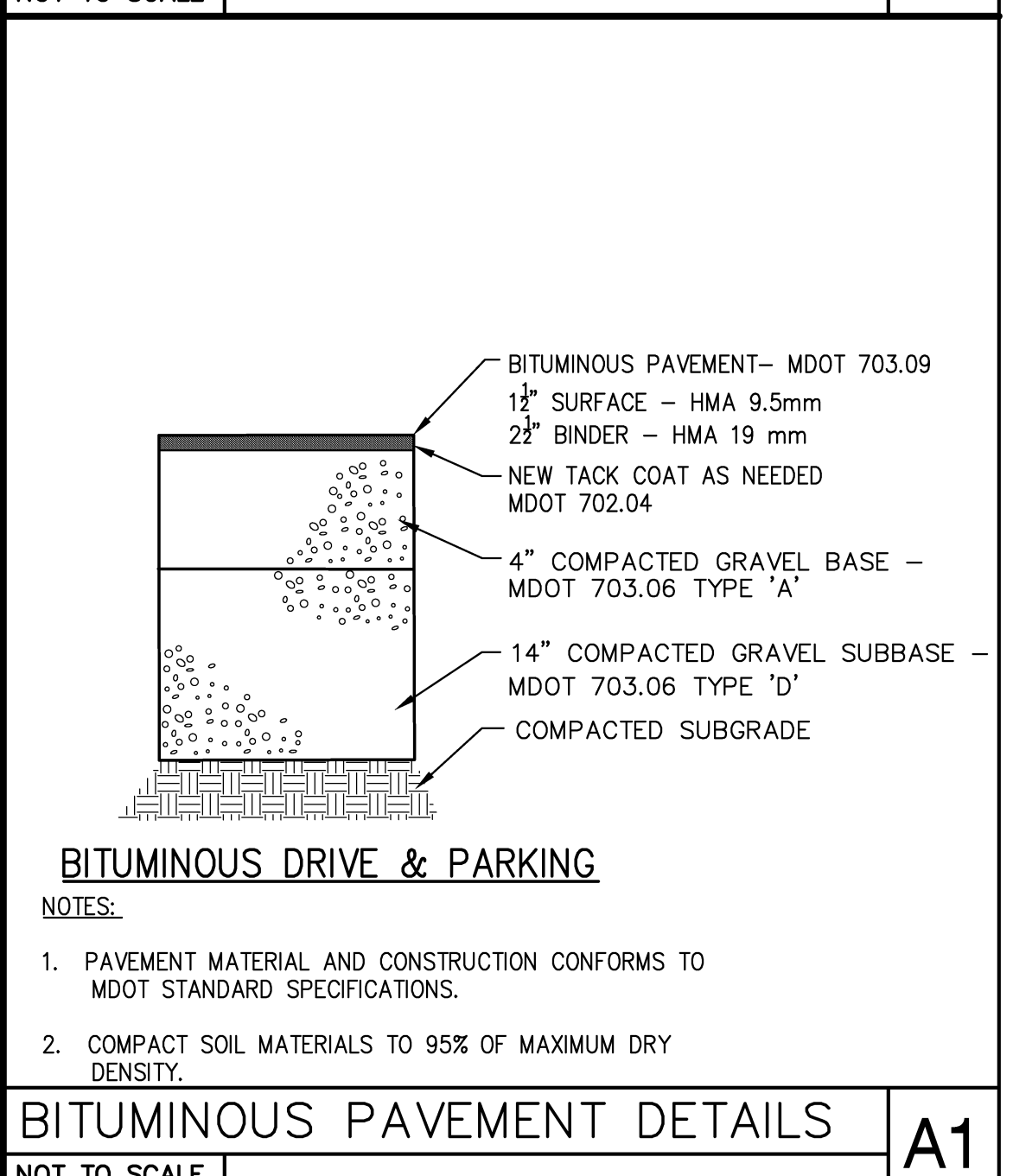

BITUMINOUS PAVEMENT DETAILS A1 NOT TO SCALE

Issues and Revisions

Mark	Date	Description
	05-22-14	PLANNING BOARD REVIEW
	07-10-14	PLANNING AUTHORITY APPROVAL
	07-25-14	ISSUED FOR CONSTRUCTION

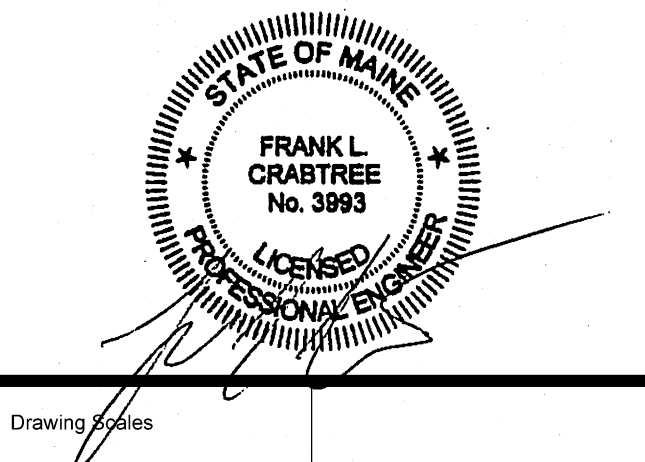

Drawing Dates

PA/PE	FLC
Drawn By	PLS

© 2014 Harriman Associates

SITE DETAILS

C7