



CHILLER MODEL: GD-5x5H

230 Volt 1 Phase	
FLA	85
MCA	95
MOC	127

230 Volt 3 Phase	
FLA	57
MCA	62
MOC	82

460 Volt 3 Phase	
FLA	26
MCA	29
MOC	38

Dimensions ¹	48"W x 84"L x 62"H
Frame	Powder Coated Steel
Housing	Powder Coated Aluminum
Tank	115 Gallon Stainless Steel
Compressor HP	5 (x2)
Condenser	Air-Cooled
Glycol Pump HP	1.5
GPM @ 25 PSI	40
Connection Size	1.5" FPT
Heat Exchanger	Stainless Steel Brazed Plate
Controls	Multi Stage Digital

Electrical Enclosure	NEMA 4
Shipping Weight	1850 lbs
Decibels @ 10'	65
Refrigerant	R404a

Cooling Capacity by Leaving Fluid Temperature ²

LFT	Btu/H	kW
20 °F	65,434	19.2
30 °F	81,700	23.9
40 °F	99,930	29.3

¹ Dimensions accurate for package chiller, remote condenser options will vary

² All capacities at 90 °F ambient

³ VFD available upon request

Chiller package consists of the following:

- Two complete refrigeration circuits
- Air-cooled condenser
- Glycol pump³
- Fluid bypass valve
- Freeze stat safety switch
- All insulated copper piping
- Powder coated steel frame
- Powder coated aluminum housing
- Insulated stainless steel glycol reservoir
- Digital temperature controller with alternating relay for equal runtime of each compressor
- Engineered high efficiency heat exchanger for maximum energy savings
- ETL (UL508) listed complete control panel with single point electrical connection, breakers, starters & safety switches
- Brass ball valves for supply and return glycol connections
- Louvered aluminum access panels for easy service & maintenance
- Factory run tested and fully charged with refrigerant

1 Year Parts and Labor Warranty

DETAIL A
SCALE 1 : 4

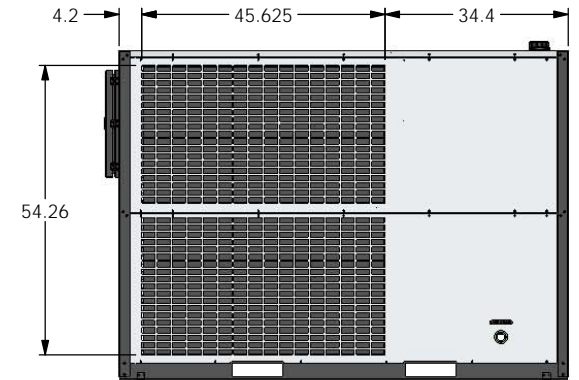
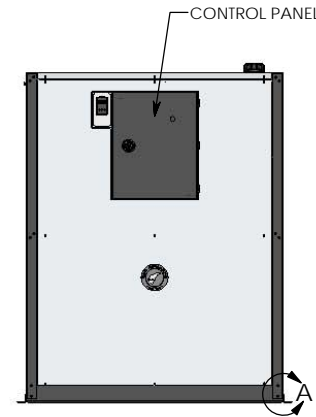
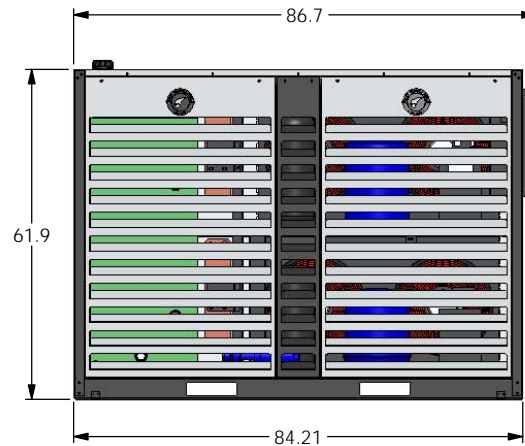
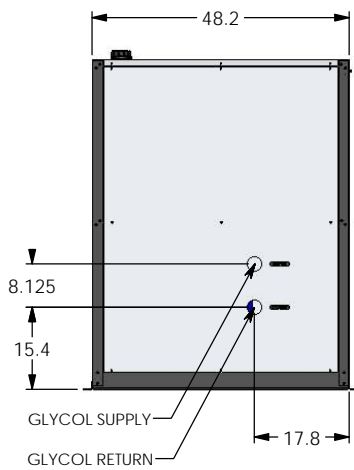
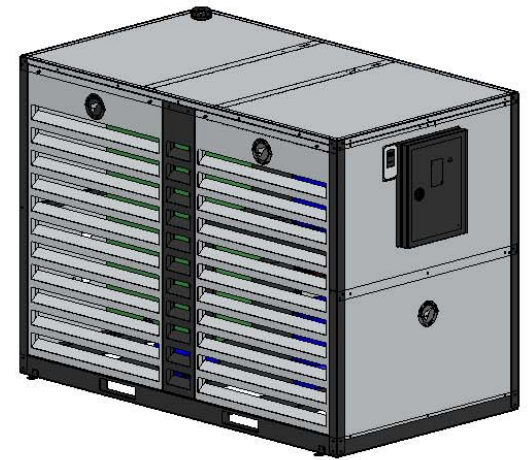
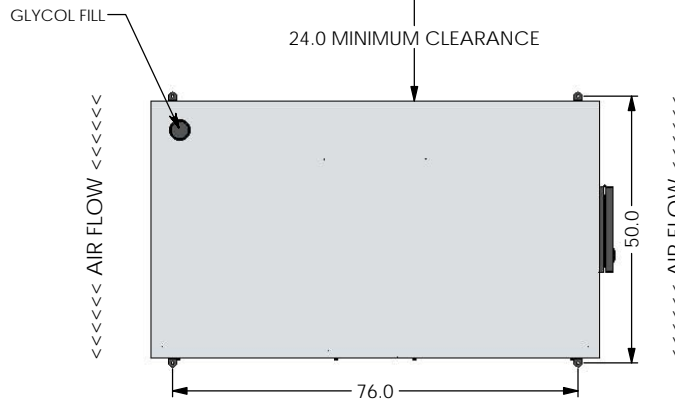
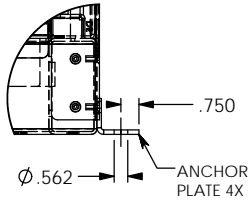

GD-5X5 / 7X7H

STATIONARY CHILLER

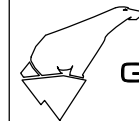

G&D CHILLERS

COMMITTED TO COLD

○ EST 1993 ○

760 BAILEY HILL ROAD EUGENE, OR 97402 - TEL (541) 345-3903 (800) 555-0973