

A4 TANK EMBED PL, PLAN VIEW
SCALE: 1" = 1'-0"

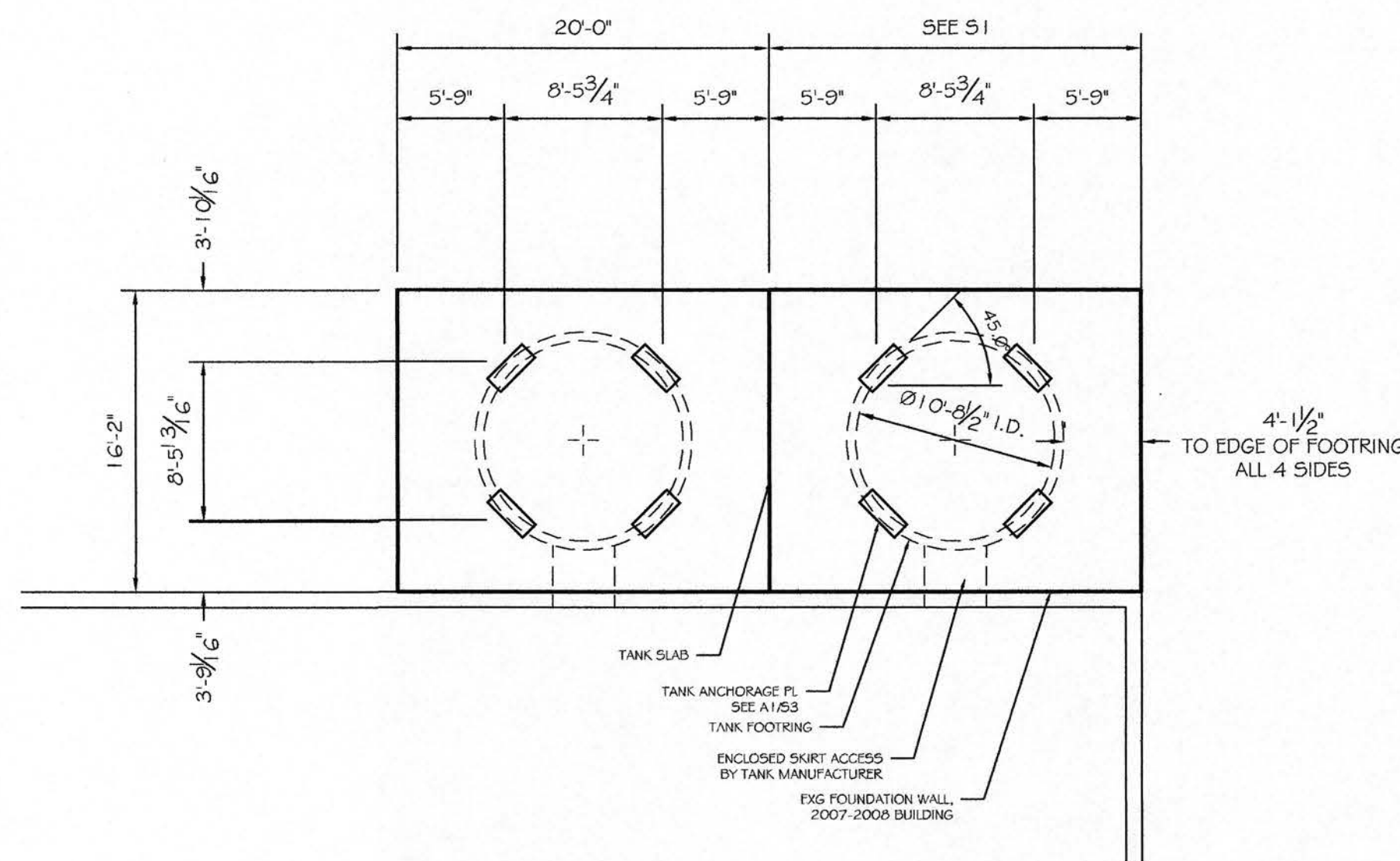

A3 TANK ANCHOR PLATE LAYOUT
SCALE: 1/8" = 1'-0"

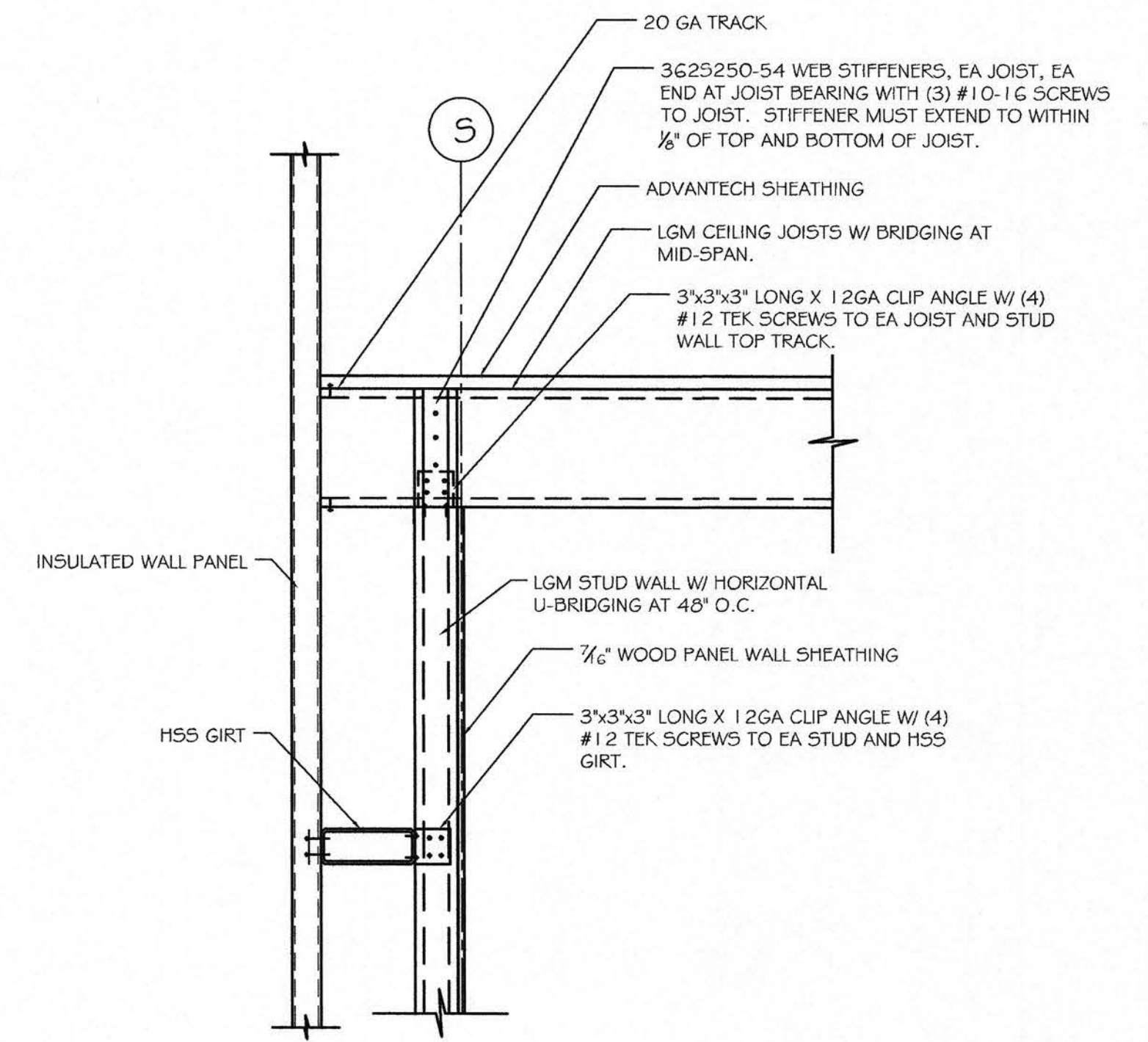

B2 OFFICE CEILING DETAIL
SCALE: 1/4" = 1'-0"

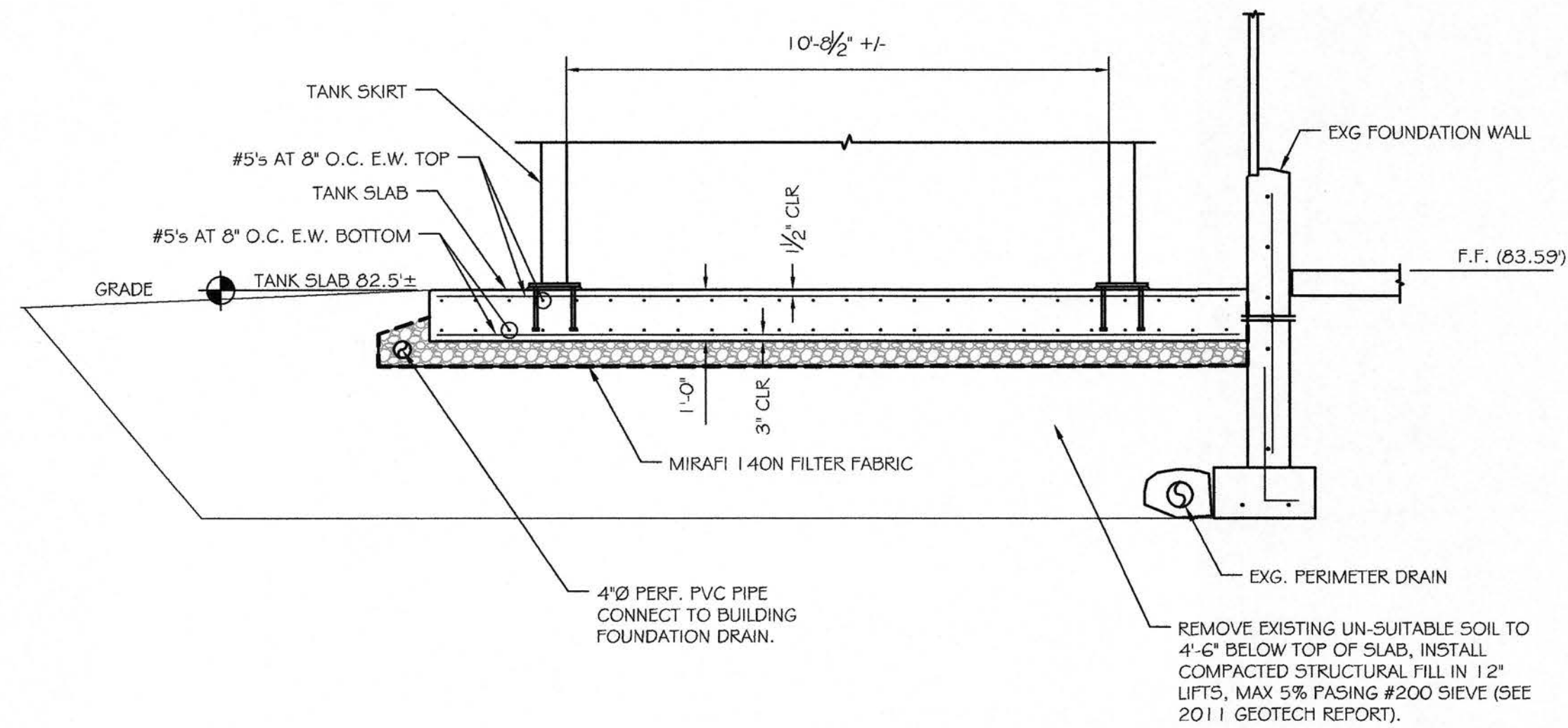

B4 TANK SLAB
SCALE: 3/8" = 1'-0"

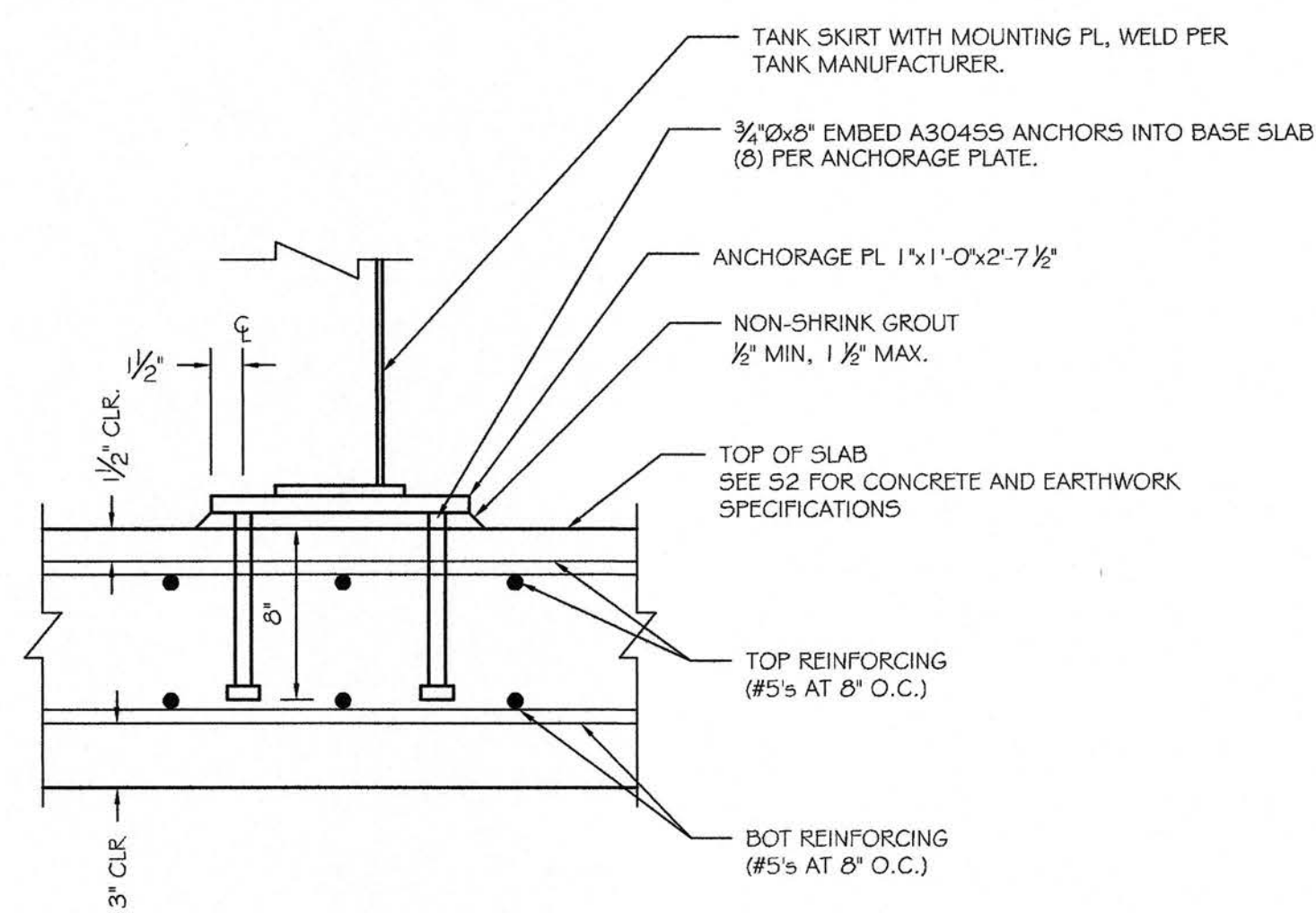

A4 TANK BASE DETAIL
SCALE: 1 1/2" = 1'-0"

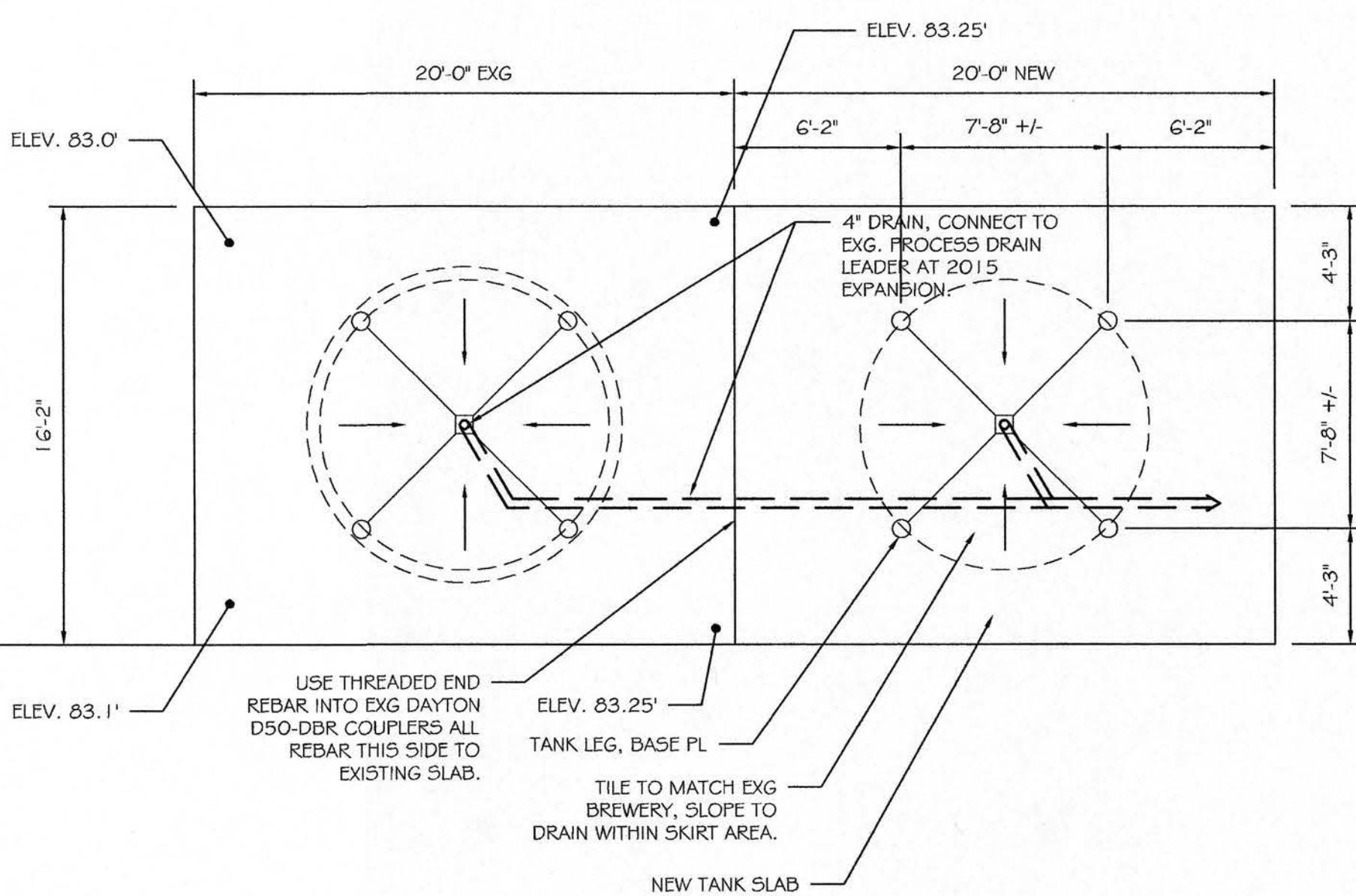

A3 TANK LAYOUT PLAN
SCALE: 3/16" = 1'-0"

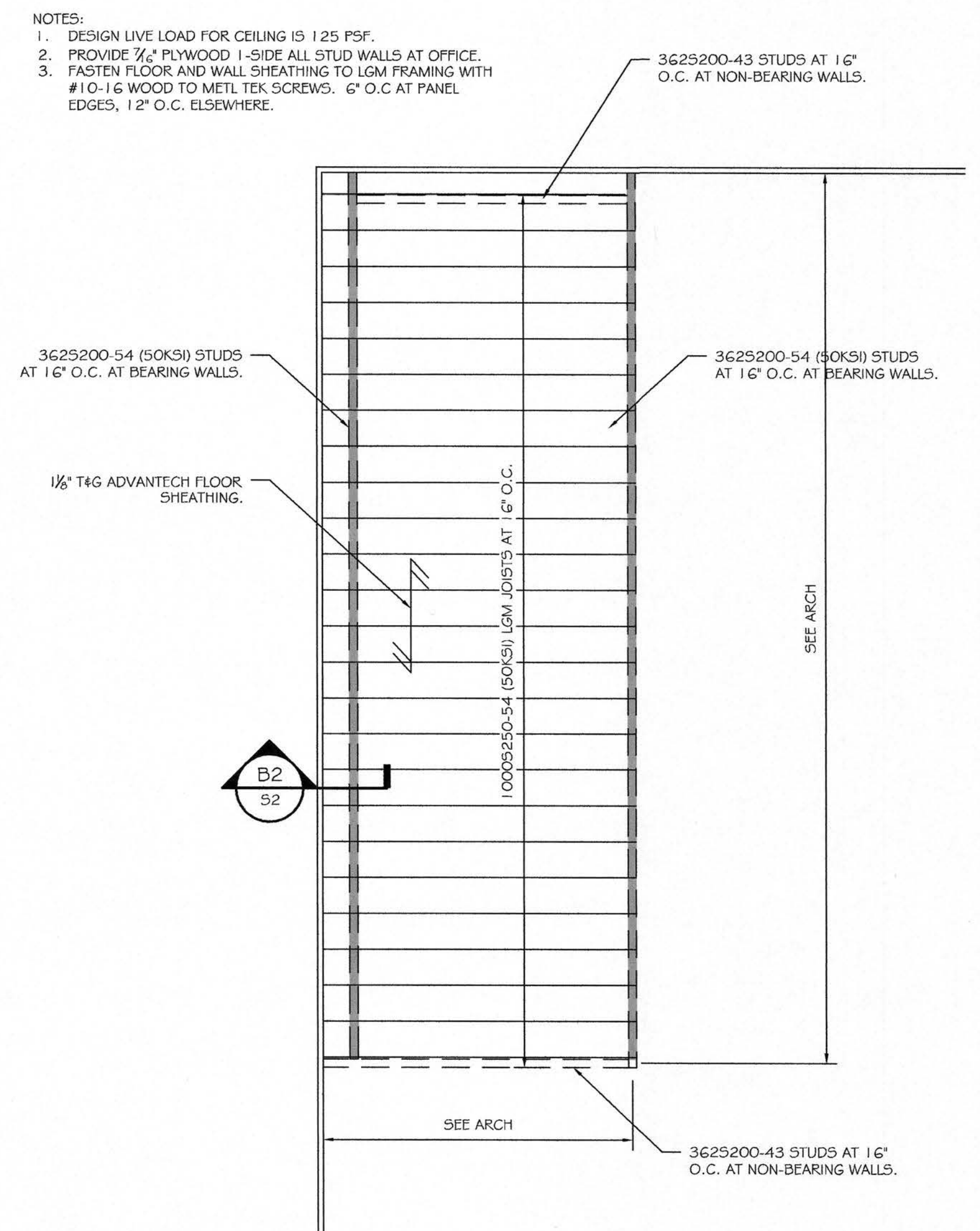

A1 OFFICE CEILING FRAMING
SCALE: 1/4" = 1'-0"

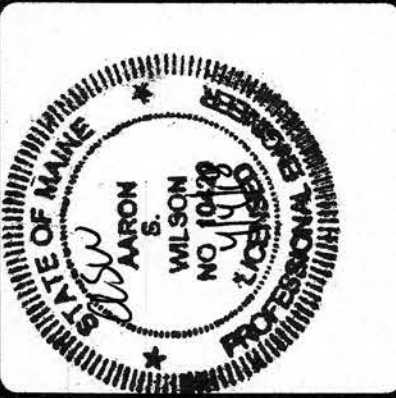

ASSOCIATED DESIGN PARTNERS INC.
Office: (207) 878-1751
Falmouth, Maine 04105
Fax: (207) 878-1788
E-Mail: adp@adpengineering.com

THIS DRAWING, DESIGN AND ELECTRONIC FILE ARE THE PROPERTY OF ASSOCIATED DESIGN PARTNERS, INC. THE REPRODUCTION, COPYING OR ANY OTHER USE OF THIS DOCUMENT WITHOUT WRITTEN CONSENT IS PROHIBITED.

PROJECT: **ALLGASH 2018 PACKAGING EXPANSION 50 INDUSTRIAL WAY, PORTLAND ME**
SHEET TITLE: **STRUCTURAL PLANS AND DETAILS ISSUED FOR PERMITTING**

REVISIONS	DESCRIPTION	DATE
No.		
BY		

DATE: 4/4/18
SCALE: AS NOTED
DESIGN BY: ASW
DRAWN BY: ASW
PROJECT NUMBER: **18001**
SHEET NO: **53**