

ENLARGED FLOOR PLAN
 1/8" = 1'-0"

NOTES:

1. SEE LS3 FOR EXTERIOR LANDINGS, RAMPS AND WALKWAYS, TYP.
2. FOR DOOR SCHEDULE SEE DWG A11
3. FOR WALL TYPES SEE DWG A10
5. REFER TO DRAWING A6 FOR RAMP FRAMING DETAILS AND A7 FOR WALL FRAMING AND OPENINGS DETAILS

FOGGER/HAZER ON SHELF @ 8' A.F.F. (COORD. LOCATION W./OWNER) SEE NOTES
 MECHANICAL EXHAUST UNIT LOCATION, DESIGN & CONTROLS BY OTHERS. OBTAIN APPROVALS FROM STATE AND CITY AUTHORITIES BEFORE INSTALLATION

REMOVE EXISTING LOUVER: INFIL TO MATCH EXISTING (VIF) (CONFIRM REMOVAL W/OWNER)

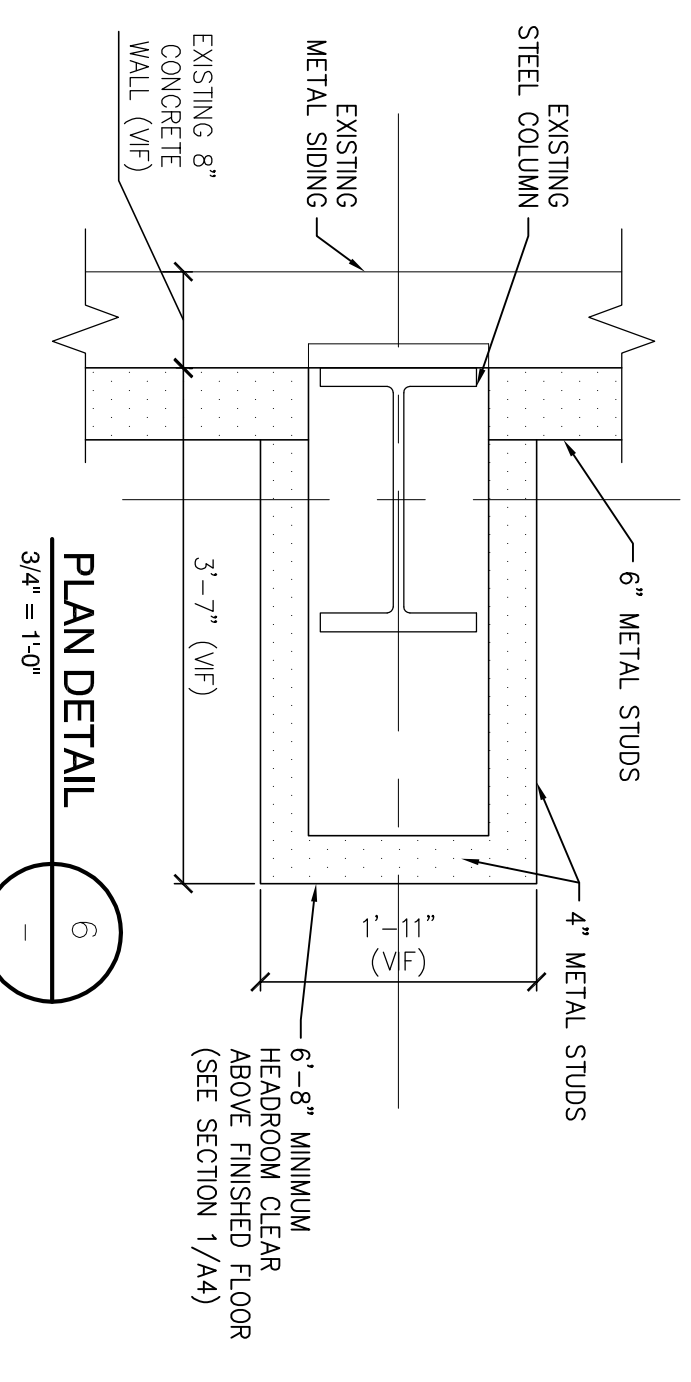

REV.	DATE	STATUS
0	2-26-15	ISSUED FOR PERMITS
2	4-10-15	GENERAL REVISIONS

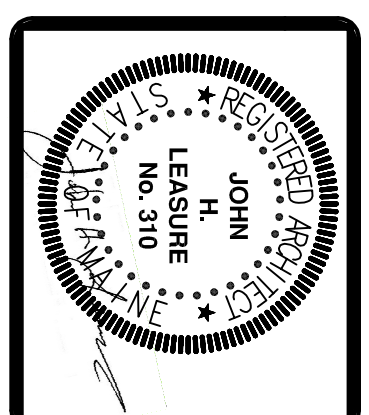

**PROPOSED LASER TAG AMUSEMENT
 SPARE TIME BOWLING
 867 RIVERSIDE STREET
 PORTLAND, MAINE**
 FLOOR PLAN - LASER TAG ARENA, ARCADE AND RESTROOMS

JOHN H. LEASURE ARCHITECT, INC.
 6 Q STREET
 SOUTH PORTLAND, MAINE 04106

