



Shield Industries, Inc.

W10

2 HOUR NFPA 251 FIRE ASSEMBLY - WOOD FRAMED WALL w/ 1/2" GYPSUM BOARD

Typical Frame Wall Assembly 1/2" unrated Gypsum Wall Board attached to 2 x 4 southern yellow pine studs at 16" o.c. with fiberglass insulation and 1-5/8" course thread dry wall screws spread per local building code

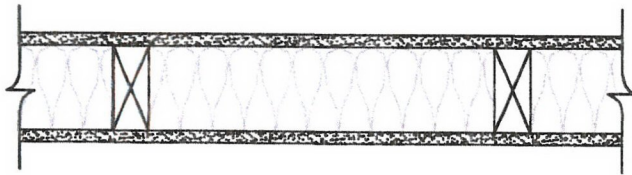

TO ACHIEVE 2 HOUR NFPA FIRE RATING:

APPLY 10 MIL THICKNESS (DRY) OF ForceField® FireGuard® E-84 TO EXPOSED SIDE OF GYPSUM BOARD

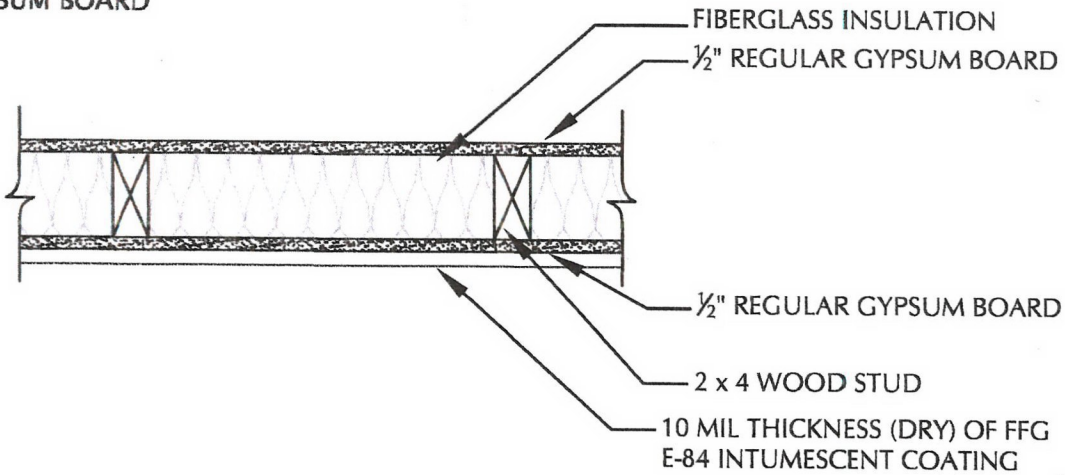

SCALE: N.T.S.

FIRE TEST ENDURANCE RATING:	2 HOUR
STANDARD TESTED TO:	NFPA - 251
FIRE TESTED LABORATORY:	GUARDIAN FIRE TESTING LABORATORIES, INC. 480 HINMAN AVE. BUFFALO, NY 14216
REPORT NO:	GL 61011-2 NFPA-251
PRODUCT:	ForceField® FireGuard® E-84 INTUMESCENT COATING (FFG E-84)
MANUFACTURER:	SHIELD INDUSTRIES, INC. 131 SMOKEHILL LANE WOODSTOCK, GA 30188

GUARDIAN
M. Joseph Pearson
11/29/13



* SEE MANUFACTURER APPLICATION INSTRUCTIONS AND SPECIFICATIONS FOR SURFACE PREPARATION AND APPLICATION PROCESS

Laura Ann Hinton 11/18/13