

1 EQUIPMENT SHELTER ELEVATION  
C-3 NTS

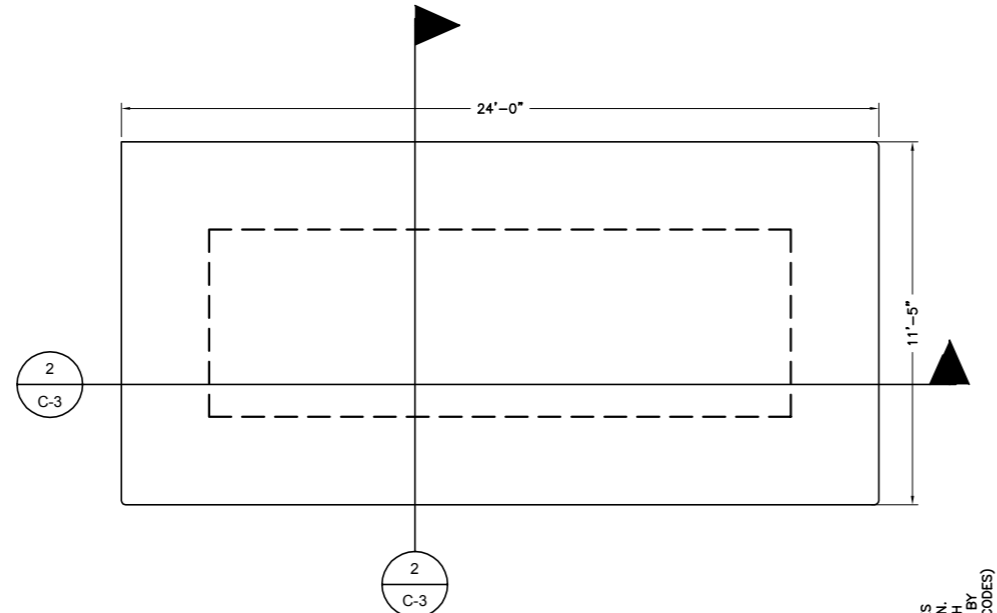

2 SHELTER FOUNDATION PLAN  
C-3 NTS

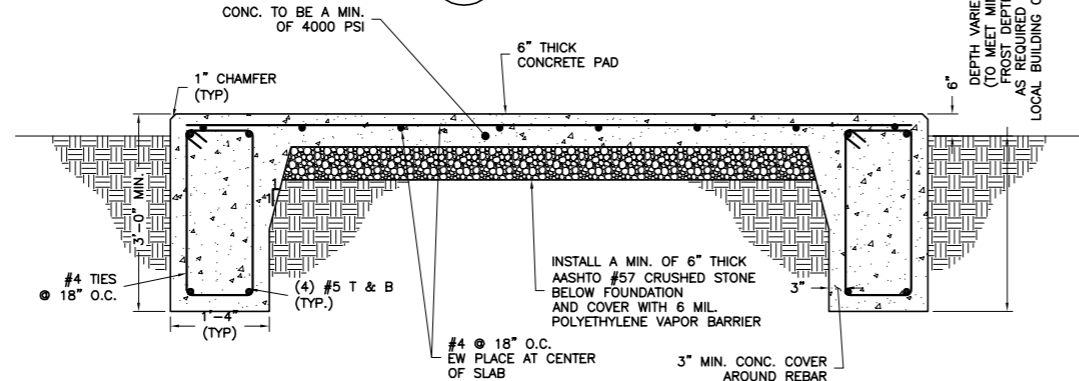

**CONCRETE GENERAL NOTES**

- ALL CONCRETE WORK SHALL CONFORM TO ACI 318-08, "BUILDING CODE REQUIREMENTS FOR REINFORCED CONCRETE" AND TO THE PROJECT SPECIFICATIONS.
- ALL CONCRETE IS TO BE NORMAL DENSITY CONCRETE WITH A MAXIMUM SLUMP OF 4 INCHES. MAXIMUM AGGREGATE SIZE 3/4 INCH. NO ADDITIONAL WATER SHALL BE ADDED TO THE CONCRETE AT THE JOB SITE.
- PROVIDE AIR ENTRAINMENT OF 4 TO 6 PERCENT IN ALL EXPOSED CONCRETE WORK WITH AIR-ENTRAINING ADMIXTURE COMPLYING WITH ASTM C 260. AT TROWEL-FINISHED FLOORS, DO NOT EXCEED AIR-ENTRAINMENT CONTENT OF 3 PERCENT.
- NO HOLES OR SLEEVES SHALL BE MADE THROUGH CONCRETE WORK OTHER THAN THOSE INDICATED ON THE STRUCTURAL DRAWINGS WITHOUT THE APPROVAL OF THE STRUCTURAL ENGINEER.
- ALL FORMWORK OFFSET TOLERANCES (PER ACI 117) TO BE CLASS A.
- FLOOR SLAB TOLERANCES TO ASTM E1155; SPECIFIED OVERALL MINIMUM VALUE OF FLATNESS F F=25 WITH LOCAL MINIMUM F F=17, AND MINIMUM VALUE OF LEVELNESS F F=20 WITH LOCAL MINIMUM F F=1 AND F F WITHIN 72 HOURS OF SLAB CONSTRUCTION.
- CABINETS ON SLAB (IF APPLICABLE). ALLOWABLE CAPACITY OF CONCRETE USED IN DESIGN MIN. 3500 PSI.

**FOUNDATION NOTES:**

- DESIGN INFORMATION AND GENERAL REQUIREMENTS**
  - 1.1 CODES**
    - DESIGN CONFORMS TO THE 2010 BUILDING CODE OF NEW YORK STATE.
    - AMERICAN CONCRETE INSTITUTE "BUILDING CODE REQUIREMENTS FOR REINFORCED CONCRETE," ACI 318-08.

- 2.1 FOUNDATIONS**
  - FOUNDATIONS HAVE BEEN DESIGNED TO BEAR ON (UNDISTURBED RESIDUAL SOILS/COMPACTED STRUCTURAL FILL), CAPABLE OF SAFELY SUPPORTING A NET ALLOWABLE BEARING PRESSURE OF 2000 PSF. IF FOUNDATION CONDITIONS PROVE UNACCEPTABLE AT ELEVATIONS SHOWN, EXCAVATION SHALL BE CARRIED DEEPER AND SHALL BE BACKFILLED WITH LEAN CONCRETE TO PLAN FOOTING BOTTOM, OR REDESIGN OF FOUNDATIONS WILL BE REQUIRED AT THE DIRECTION OF THE ENGINEER.

- DESIGN, FURNISH AND INSTALL ALL TEMPORARY SHEETING, SHORING AND DRAINAGE NECESSARY TO MAINTAIN THE EXCAVATION AND PROTECT SURROUNDING STRUCTURES AND UTILITIES.

**3. CONCRETE**

- CONCRETE CONSTRUCTION SHALL CONFORM TO "SPECIFICATIONS FOR STRUCTURAL CONCRETE FOR BUILDINGS," (ACI 301-10).
- FORMWORK SHALL CONFORM TO ACI 301 "SPECIFICATIONS FOR STRUCTURAL CONCRETE FOR BUILDINGS."

**3.2 REINFORCEMENT**

- REINFORCING STEEL ASTM A615, GRADE 60. WELDED WIRE ASTM A185 (FLAT SHEET). LAPS 40 BAR DIAMETERS UNLESS NOTED. BARS SHALL BE SECURELY HELD IN ACCURATE POSITION BY SUITABLE ACCESSORIES, TIE BARS, SUPPORT BARS, ETC. HOOK LENGTHS SHALL BE 12 BAR DIAMETERS.
- CONCRETE COVER FOR REINFORCING BARS SHALL BE AS FOLLOWS, UNLESS OTHERWISE NOTED.
 

FOOTINGS & SLABS CAST AGAINST GROUND	3"
CONCRETE TO BE IN CONTACT WITH GROUND OR WEATHER AT BARS GREATER THAN #5	2"
AT BARS #5 OR LESS	1-1/2"
CONCRETE NOT TO BE EXPOSED TO GROUND OR WEATHER BEAMS, GIRDERS & COLUMNS	1-1/2"
SLABS & WALLS	3/4"

**3.3 CAST-IN-PLACE-CONCRETE**

- MINIMUM 28 DAY CYLINDER STRENGTH AND MAXIMUM SLUMP, PRIOR TO ADDITION OF SUPER PLASTICIZERS, AS FOLLOWS:
 

	F <sub>C</sub> (PSI)	SLUMP
CLASS I FOOTINGS	4000	3"
CLASS II FOOTINGS	4000	3"
CLASS III INTERIOR ELEVATED	4000	4"
SLABS & WALLS		
CLASS V OTHER WORK	4000	4"
CLASS VI LEAN CONCRETE FOR OVER EXCAVATION OF FOUNDATIONS	2000	N/A
- MIX DESIGN TO BE IN ACCORDANCE WITH ACI 318, CHAPTER 5. NO CALCIUM CHLORIDE OR ADMIXTURE CONTAINING CHLORIDES SHALL BE USED IN ANY CONCRETE.
- COARSE AGGREGATE FOR NORMAL WEIGHT CONCRETE SHALL CONFORM TO ASTM C33 SIZE #57. COARSE AGGREGATE FOR LIGHT WEIGHT CONCRETE SHALL CONFORM TO ASTM C330 GRADED 3/4" TO 1 1/4".
- COLD WEATHER PLACEMENT SHALL COMPLY WITH ACI 306.1
- HOT WEATHER PLACEMENT SHALL COMPLY WITH ACI 305 R.
- CHAMFER ALL EXPOSED EDGES 3/4".
- THE MAXIMUM TEMPERATURE OF ALL CONCRETE AT DELIVERY TO THE SITE SHALL BE 85°F, TOTAL DELIVERY TIME SHALL BE LESS THEN 75 MINUTES.

**4. ANCHORING**

- USE 3/4" # F1554 GRADE 36 ANCHOR RODS WITH 9" MINIMUM EMBEDMENT TYPICAL FOR SHELTER CONNECTION UNLESS OTHERWISE DIRECTED BY SHELTER MANUFACTURER.



**NB+C ENGINEERING SERVICES, LLC.**  
100 APOLLO DRIVE  
SUITE 303  
CHELMSFORD, MA 01824  
(978) 856-6308



ME5372  
LUCAS TREE  
636 RIVERSIDE STREET  
PORTLAND, ME 04103  
CITY OF PORTLAND

**REVISIONS**

REV	DATE	DESCRIPTION	BY
7	12/12/16	REVISED PER RF SHEET	MJS
6	02/09/15	FINAL CDs	KMD
5	01/05/15	REVISED PER RF SHEET	KMD
4	08/27/14	REVISED COORDINATES	KMD
3	06/06/14	REVISED PER COMMENTS	DAK
2	05/22/14	PRELIMINARY CDs	DAK
1	03/20/14	REVISED PER COMMENTS	DAK
0	10/10/13	PRELIMINARY ZDs	DAK

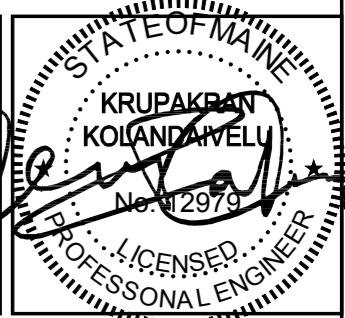

KRUPAKARAN KOLANDAVELU P.E.  
ME PROFESSIONAL ENGINEER LIC. #12979

**SHELTER & FOUNDATION DETAILS**

**C-3**

ENGINEER  
APPLICANT  
SITE INFORMATION  
DESIGN RECORD  
PROFESSIONAL STAMP  
ENGINEER  
SHEET TITLE  
SHEET NUMBER