



ORIENT LEGS WITH P/N STAMP
TOWARD BOTTOM OF SECTION

ORIENT ANGLES WITH STAMPED
END TOWARD TOP OF SECTION

** DIAGONAL ANGLES MUST BE INSTALLED
WITH THE NON-BOLTED FACE UP,  
THIS MAY BE ON THE OPPOSITE SIDE OF THE
SIDE PLATE THAN WHAT IS SHOWN IN THE DETAIL.

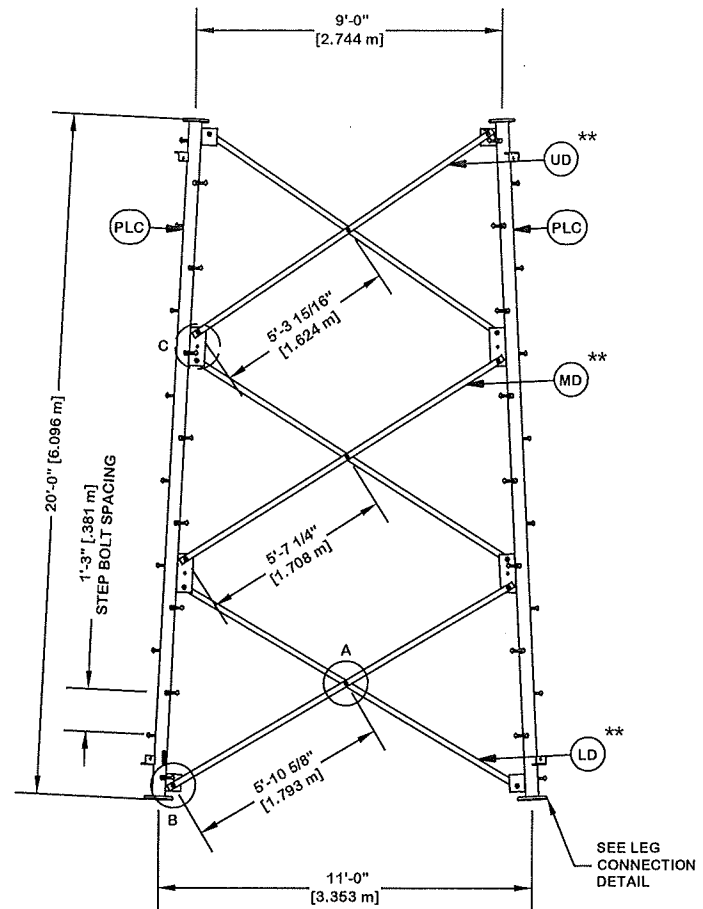

PARTS LIST					
ITEM	QTY	PART NO.	PART DESCRIPTION	UNIT WT.	NET WT.
PLC	3	226206	PIPE LEG SECTION 20' - 0" (CLIMBING) 6" SCH. 40 PI	476.980	1430.940
STP	48	228189	STEP BOLT ASSY 5/8"-11 X 7" W/ LOCK WASHER HEAVY	1.100	52.800
LD	6	231347	ANGLE V-11 LOW 139 1/32" (W/45 CLIPPED)	37.350	224.100
MB	9	227580	5/8"-11 X 2-1/4" A325T HOT DIPPED GALV. BOLT (FULL)	0.640	5.760
AS	9	124838	MID-DIAGONAL SPACER 11/16" HOLE 3/8" THICK	0.450	4.050
MN	9	312501	5/8"-11 HOT DIPPED GALVANIZED NUT	0.120	1.080
ML	9	312123	5/8" GALVANIZED LOCKWASHER (53-22230)	0.020	0.180
SL	36	312153	3/4" GALVANIZED LOCKWASHER	0.030	1.080
SN	36	312502	3/4"-10 HOT DIPPED GALVANIZED NUT	0.190	6.840
SB	36	227579	3/4"-10 X 2-1/4" A-325T BOLT WITH FULL THREAD	0.420	15.120
MD	6	225037	ANGLE V-11 MID 132 1/4"	35.520	213.120
UD	6	225038	ANGLE V-11 UP 126 5/8"	33.740	202.440
LCB	24	227668	3/4"-10 X 3-1/2" A-325T BOLT WITH FULL THREAD	0.540	12.960
LCF	24	312152	3/4" GALVANIZED FLAT WASHER (F436)	0.080	1.920
LCL	24	312153	3/4" GALVANIZED LOCKWASHER	0.030	0.720
LCN	24	312502	3/4"-10 HOT DIPPED GALVANIZED NUT	0.190	4.560
Total Wt				2177.67 lb [988.68 kg]	

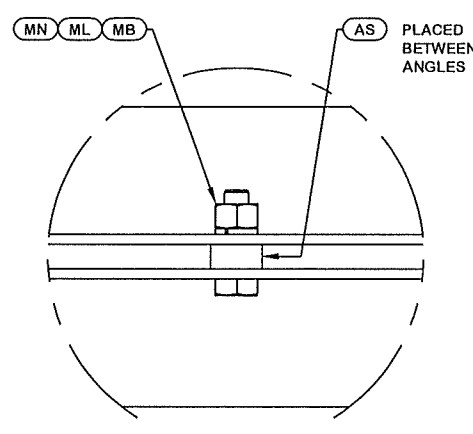

DETAIL A
ANGLE INTERSECTION CONNECTION

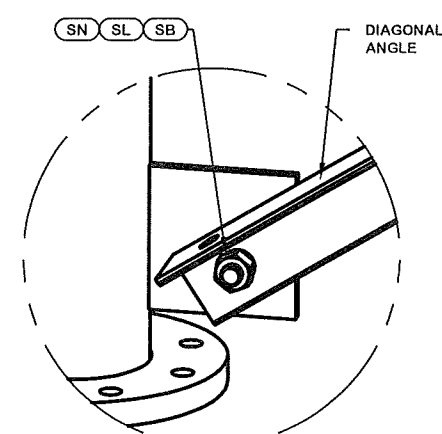

DETAIL B
END SIDE PLATE ANGLE CONNECTION

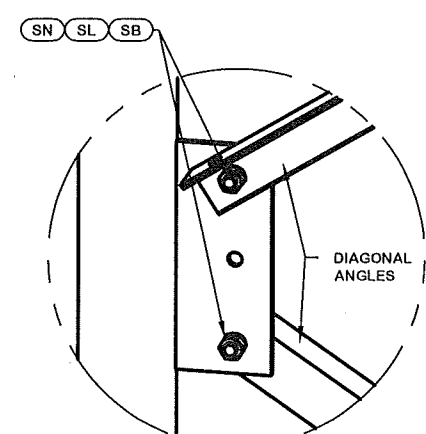

DETAIL C
MID SIDE PLATE ANGLE CONNECTION

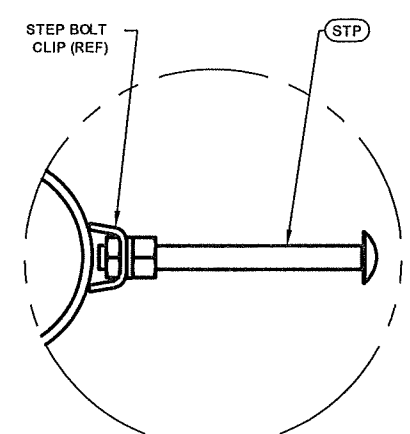

STEP BOLT INSTALLATION

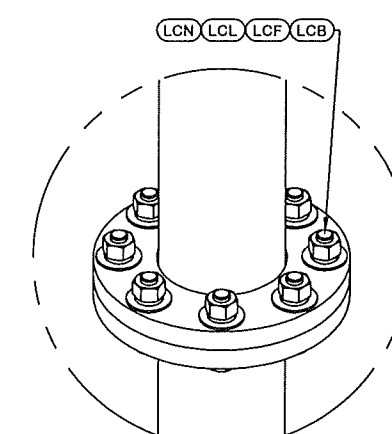

LEG TO LEG CONNECTION
(SIDE PLATES NOT SHOWN FOR CLARITY)

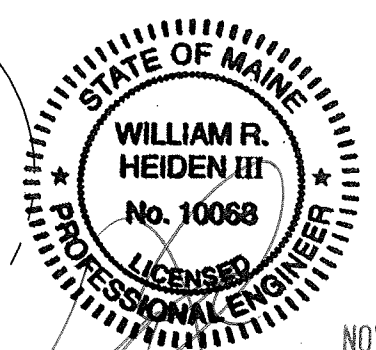

@A <ACBATCH>		SKK	8/10/2016
REV	DESCRIPTION OF REVISIONS	CPD	BY DATE
REVISION HISTORY			

SITE	CITY OF PORTLAND FD, ME MOTOROLA SOLUTIONS U 19 X 180'
COPYRIGHT 2013	
PROPRIETARY NOTE:	THE DATA AND TECHNIQUES CONTAINED IN THIS DRAWING ARE PROPRIETARY INFORMATION OF VALMONT INDUSTRIES AND CONSIDERED A TRADE SECRET. ANY USE OR DISCLOSURE WITHOUT THE CONSENT OF VALMONT INDUSTRIES IS STRICTLY PROHIBITED.

DESCRIPTION	SECTION V-11.0 (80' - 100' ELEVATION)
STRUCTURE APPROVAL	SKK 8/10/2016
FOUNDATION APPROVAL	

valmont 

1-877-467-4763 Plymouth, IN
1-800-547-2151 Salem, OR

STRUCTURES

ENG. FILE NO. 324370

DWG. NO. 268614T

PAGE 7 OF 11