

DISPLAY THIS CARD ON PRINCIPAL FRONTAGE OF WORK
CITY OF PORTLAND

Please Read
 Application And
 Notes, If Any,
 Attached

BUILDING INSPECTION

PERMIT

Permit Number: 080396

MAY 1 2000

316 B008001 CITY OF PORTLAND

This is to certify that IRVING OIL CORPORATION

has permission to Increase the size of 3 canopy signs

AT 270 RIVERSIDE ST

provided that the person or persons, firm or corporation accepting this permit shall comply with all of the provisions of the Statutes of Maine and of the Ordinances of the City of Portland regulating the construction, maintenance and use of buildings and structures, and of the application on file in this department.

Apply to Public Works for street line and grade if nature of work requires such information.

Notification of inspection must be given and work in permit in progress before this building or part thereof is closed or closed-in. FOUR NOTICES IS REQUIRED.

A certificate of occupancy must be procured by owner before this building or part thereof is occupied.

OTHER REQUIRED APPROVALS

Fire Dept. _____

Health Dept. _____

Appeal Board _____

Other _____

Department Name

Director - Building & Inspection Services

PENALTY FOR REMOVING THIS CARD

City of Portland, Maine - Building or Use Permit

389 Congress Street, 04101 Tel: (207) 874-8703, Fax: (207) 874-8716

Permit No: 08-0396	Date Applied For: 04/23/2008	CBL: 316 B008001
-----------------------	---------------------------------	---------------------

Location of Construction: 270 RIVERSIDE ST	Owner Name: IRVING OIL CORPORATION	Owner Address: 190 COMMERCE WAY	Phone:
Business Name:	Contractor Name:	Contractor Address:	Phone
Lessee/Buyer's Name	Phone:	Permit Type: Signs - Permanent	

Proposed Use: Irving Oil Corp - Convenience Store w/fuel - Amendment to permit #08-0234. Increase the size of 3 canopy signs	Proposed Project Description: Increase the size of 3 canopy signs
---	--

Dept: Zoning Status: Approved with Conditions Reviewer: Ann Machado Approval Date: 04/28/2008 Note: Ok to Issue: <input checked="" type="checkbox"/> 1) The same conditions for permit #08-0234 apply to this permit.
Dept: Building Status: Approved with Conditions Reviewer: Tammy Munson Approval Date: 05/01/2008 Note: Ok to Issue: <input checked="" type="checkbox"/> 1) Signage Installation to comply with Chapter 31 of the IBC 2003 building code.

City of Portland, Maine - Building or Use Permit Application

389 Congress Street, 04101 Tel: (207) 874-8703, Fax: (207) 874-8716

Permit No: 08-0396	Issue Date:	CBL: 316 B008001
-----------------------	-------------	---------------------

Location of Construction: 270 RIVERSIDE ST	Owner Name: IRVING OIL CORPORATION	Owner Address: 190 COMMERCE WAY	Phone:
Business Name:	Contractor Name:	Contractor Address:	Phone:
Lessee/Buyer's Name	Phone:	Permit Type: Signs - Permanent	Zone: B-4

Past Use: Irving Oil Corp - Convenience Store w/fuel - Amendment to permit #08-0234.	Proposed Use: Irving Oil Corp - Convenience Store w/fuel - Amendment to permit #08-0234. Increase the size of 3 canopy signs	Permit Fee: \$58.60	Cost of Work: \$0.00	CEO District: 5
Proposed Project Description: Increase the size of 3 canopy signs		FIRE DEPT: <input type="checkbox"/> Approved <input checked="" type="checkbox"/> Denied <i>N/A</i>	INSPECTION: Use Group: <i>U</i> Type: <i>Sign</i> <i>ZBC 2003</i>	
		Signature: <i>[Signature]</i>		
PEDESTRIAN ACTIVITIES DISTRICT (P.A.D.)				
Action: <input type="checkbox"/> Approved <input type="checkbox"/> Approved w/Conditions <input type="checkbox"/> Denied				
Signature: _____ Date: _____				

Permit Taken By: lmd	Date Applied For: 04/23/2008	Zoning Approval
-------------------------	---------------------------------	------------------------

- This permit application does not preclude the Applicant(s) from meeting applicable State and Federal Rules.
- Building permits do not include plumbing, septic or electrical work.
- Building permits are void if work is not started within six (6) months of the date of issuance. False information may invalidate a building permit and stop all work..

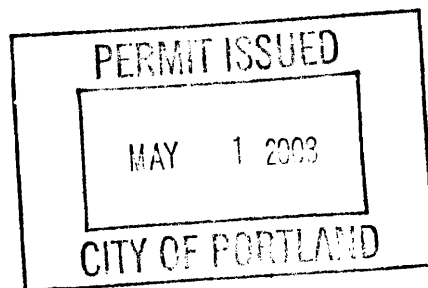

Special Zone or Reviews <input type="checkbox"/> Shoreland <input type="checkbox"/> Wetland <input type="checkbox"/> Flood Zone <input type="checkbox"/> Subdivision <input type="checkbox"/> Site Plan Maj <input type="checkbox"/> Minor <input type="checkbox"/> MM <input type="checkbox"/> Date: <i>4/28/08</i> <i>ASCM</i>	Zoning Appeal <input type="checkbox"/> Variance <input type="checkbox"/> Miscellaneous <input type="checkbox"/> Conditional Use <input type="checkbox"/> Interpretation <input type="checkbox"/> Approved <input type="checkbox"/> Denied Date: _____	Historic Preservation <input checked="" type="checkbox"/> Not in District or Landmark <input type="checkbox"/> Does Not Require Review <input type="checkbox"/> Requires Review <input type="checkbox"/> Approved <input type="checkbox"/> Approved w/Conditions <input type="checkbox"/> Denied Date: <i>ARM</i>
--	---	---

CERTIFICATION

I hereby certify that I am the owner of record of the named property, or that the proposed work is authorized by the owner of record and that I have been authorized by the owner to make this application as his authorized agent and I agree to conform to all applicable laws of this jurisdiction. In addition, if a permit for work described in the application is issued, I certify that the code official's authorized representative shall have the authority to enter all areas covered by such permit at any reasonable hour to enforce the provision of the code(s) applicable to such permit.

SIGNATURE OF APPLICANT	ADDRESS	DATE	PHONE
RESPONSIBLE PERSON IN CHARGE OF WORK, TITLE		DATE	PHONE



Signage/Awning Permit Application

If you or the property owner owes real estate or personal property taxes or user charges on any property within the City, payment arrangements must be made before permits of any kind are accepted.

Location/Address of Construction: <u>270 Riverside St</u>		
Tax Assessor's Chart, Block & Lot Chart# Block# Lot# <u>316 B 008</u>	Owner: <u>Irving Oil Corp.</u> <u>190 Commerce Way</u> <u>Portsmouth NH 03801</u>	Telephone:
Lessee/Buyer's Name (If Applicable)	Contractor name, address & telephone: <u>TBD</u>	Total s.f. of signage x \$2.00 Per s.f. plus \$30.00/\$65.00 For H.D. signage= Total Fee: \$ _____ Awning Fee= cost of work _____ Total Fee: \$ _____
Who should we contact when the permit is ready: <u>Carolyn Parker</u> phone: <u>774-239-2781</u>		
Tenant/allocated building space frontage (feet): Length: _____ Height: _____ Lot Frontage (feet) <u>1</u> Single Tenant or Multi Tenant Lot _____		
Current Specific use: <u>convenience store w/ fuel facility</u> If vacant, what was prior use: _____ Proposed Use: <u>same</u>		
Information on proposed sign(s): <u>amend permit 08-0234 - increase size of canopy sign</u> Freestanding (e.g., pole) sign? Yes _____ No _____ Dimensions proposed: _____ Height from grade: _____ Bldg. wall sign? (attached to bldg) Yes _____ No _____ Dimensions proposed: _____		
Proposed awning? Yes _____ No _____ Is awning backlit? Yes _____ No _____ Height of awning: _____ Length of awning: _____ Depth: _____ Is there any communication, message, trademark or symbol on it? Yes _____ No _____ If yes, total s.f. of panels w/communications, message, trademark or symbol: _____ s.f.		
Information on existing and previously permitted sign(s): <u>see details</u> Freestanding (e.g., pole) sign? Yes _____ No _____ Dimensions: _____ Bldg. wall sign? (attached to bldg) Yes _____ No _____ Dimensions: _____ Awning? Yes _____ No _____ Sq. ft. area of awning w/communication: _____		
A site sketch and building sketch showing exactly where existing and new signage is located must be provided. Sketches and/or pictures of proposed signage and existing building are also required.		

**Please submit all of the information outlined in the Sign/Awning Application Checklist.
Failure to do so may result in the automatic denial of your permit.**

In order to be sure the City fully understands the full scope of the project, the Planning and Development Department may request additional information prior to the issuance of a permit. For further information visit us on-line at www.portlandmaine.gov, stop by the Building Inspections office, room 315 City Hall or call 874-8703.

I hereby certify that I am the Owner of record of the named property, or that the owner of record authorizes the proposed work and that I have been authorized by the owner to make this application as his/her authorized agent. I agree to conform to all applicable laws of this jurisdiction. In addition, if a permit for work described in this application is issued, I certify that the Code Official's authorized representative shall have the authority to enter all areas covered by this permit at any reasonable hour to enforce the provisions of the codes applicable to this permit.

Signature of applicant: <u>see cover letter</u>	Date:
---	-------

This is not a permit; you may not commence ANY work until the permit is issued.

CORE STATES ENGINEERING

One Harris Street
Newburyport, MA 01950
978.462.5788
fax 978.462.5723

AFFILIATE
PEI
EQUIPMENT INSURANCE

VIA FEDERAL EXPRESS

April 18, 2008

Ms. Ann Machado
City of Portland
389 Congress Street
Inspection Division – Room 315
Portland, ME 04101

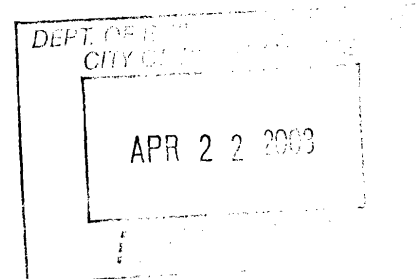

**RE: Exterior Re-image – Irving Oil
270 Riverside Street, Portland, ME
CoreStates Project #: IRV-8641**

Dear Ms. Machado:

Per Carolyn Parker's request, please find attached two (2) copies of the revised Proposed Exterior Brand Upgrade plans (drawings A50 and A51 revision B) for your review.

Upon further review of the site, Irving would like to make a few additional modifications to the proposed upgrade. Specifically, Irving would like to install their standard canopy fascia (including the LED light tube and associated canopy logo signs). Carolyn e-mailed the specific details of the canopy fascia to you and we have attached a hard copy for your file. Additionally, Irving is proposing to add external illumination to the diesel canopy logos as detailed on drawing A51.

Please review the attached information and feel free to give us a call with any questions. We are assuming that the building permit will need to be re-issued to address the minor increase in square footage (the integral canopy logos are slightly larger than the surface mount logos originally proposed).

Again, please do not hesitate to contact us with any questions, comment or concerns.

Sincerely,

CORE STATES ENGINEERING

A handwritten signature in black ink, appearing to read "Robert C. Schuler".

Robert C. Schuler, P.E.

From: "Carolyn Parker" <capconsulting@verizon.net>
To: <amachado@portlandmaine.gov>
Date: 4/17/2008 10:57:36 AM
Subject: Irving Oil

Ann,

Attached please find the detail for the proposed canopy fascia that Irving Oil wishes to use on the canopy t 270 Riverside Street.

As I mentioned revised plans will be sent to you for your files. Let me know if there will be an additional fee. Call my cell if any questions. Thank you, CAP

Rob send the revised draweings to:
City of Portland
389 Congress Street
Inspections Division - Room 315
Portland, ME 04101

Attn: Ms. Ann Machado

Carolyn A. Parker Consulting
3 Lorion Avenue
Worcester, MA 01606
Office: (508) 853-1167
Fax: (508) 853-1176
Cell: (774) 239-2781
email: <mailto:capconsulting@verizon.net> capconsulting@verizon.net

CC: "Rob Schuler" <rschuler@core-eng.com>

CITY OF PORTLAND
DEPARTMENT OF PLANNING & URBAN DEVELOPMENT
389 Congress Street
Portland, Maine 04101

INVOICE FOR PERMIT FEES

Application No: 8-0234	Applicant: IRVING OIL CORPORATION
Project Name: Replace existing signage - one new	Location: 270 RIVERSIDE ST
CBL: 316 B008001	Development Type:
Invoice Date: 03/17/2008	

Previous Balance	-	Payment Received	+	Current Fees	-	Current Payment	=	Total Due	Payment Due Date
\$0.00		\$0.00		\$387.40		\$568.80		\$0.00	On Receipt

Previous Balance

\$0.00

Fee Description	Qty	Fee/Deposit Charge
Amendment to App First \$1000	1	\$30.00
Signs	1	\$30.00
Signs sq. feet		\$298.80
Signs sq. feet	14.3	\$28.60
		\$387.40

Total Current Fees: + \$387.40

Total Current Payments: - \$568.80

Amount Due Now: (\$181.40)

Bill to: IRVING OIL CORPORATION
190 COMMERCE WAY
PORTSMOUTH, NH 03801

CBL 316 B008001
Application No: 8-0234
Invoice Date: 03/17/2008
Invoice No: 30555
Total Amt Due: \$0.00
Payment Amount: \$568.80

Make checks payable to the *City of Portland*, ATTN: Inspections, 3rd Floor, 389 Congress Street, Portland, ME 04101.

From: "Carolyn Parker" <capconsulting@verizon.net>
To: <amachado@portlandmaine.gov>
Date: 4/18/2008 12:55:27 PM
Subject: Irving Oil 270 Riverside Road. *316-B-028*

Ann,

A new set of drawings with the new proposed canopy fascia system and logo's are being mailed to your office. Please reissue the Building Permit #080234 to reflect this. Also it appears that the building permit you sent says to replicate 33 signs for a total of 285.4 s.f - I believe the total number signs and square feet is incorrect.

- It has been changed on the permit.

If you have any questions please call Rob Schuler at 978-462-5788 since I will be away next week.

If you find everything is fine please fax the new permit to both 508-853-1176 and 978-462-5823. Thank you in advance for your assistance. CAP

Carolyn A. Parker Consulting
3 Lorion Avenue
Worcester, MA 01606
Office: (508) 853-1167
Fax: (508) 853-1176
Cell: (774) 239-2781
email: <mailto:capconsulting@verizon.net> capconsulting@verizon.net

CC: "Rob Schuler" <rschuler@core-eng.com>

CORE STATES ENGINEERING

4191 Pleasant Hill Rd. 44355 Premier Plaza 379 Campus Drive 86 King Street
 Suite 400 Suite 240 Suite 150 Suite 200
 Duluth, GA 30096 Ashburn VA 20147 Somerset, NJ 08873 St. John, New Brunswick
 770-242-9550 703-723-9145 732-667-9500 506-633-8448
 Fax 770-242-9560 Fax 703-723-9657 Fax 732-667-9501 Fax 506-633-8449
 Acct Fax 678-740-0136

One Harris Street 50 Crestwood Executive 7251 Pineville Matthews 3904 Corporex Pk Dr.
Newburyport, MA 01950 Suite 500 Suite 200 Suite 125
978-462-5788 St. Louis, MO 63126 Charlotte, NC 28226 Tampa, FL 33619
Fax: 978-462-5723 314-843-4320 704-927-8760 813-490-1755
 Fax: 314-843-4323 Fax: 704-927-8761 Fax: 813-490-1759

751 Park of Commerce 216 East Poplar Street 7365 Carnelian Street
 Suite 124 Rogers, AR 72756 Suite 210
 Boca Raton, FL 33487 479-986-4400 Rancho Cucamonga, CA 91730
 561-997-6273 Fax: 479-986-4401 909-581-1202
 Fax: 561-997-6963 Fax: 909-581-1203

LETTER OF TRANSMITTAL

Date: April 18, 2008

Project Name: Irving Oil

Project Number: IRV-8641

Task Number: -

Site Location: Portland, ME

270 Riverside St.

To: City of Portland - Inspections Division

389 Congress St., Room 315

Portland, ME 04101

Attn: Ann Machado

Phone: 207-874-8707

WE ARE SENDING YOU:

Plans Reports Letter Specifications Photocopies
 Prints Other:

VIA:

Overnight US Mail Courier Pickup Other

COPIES	DATE OR NO	REV DATE	DESCRIPTION
1			Cover Letter
2		B	A50 Revised Proposed Exterior Brand Upgrade plans
2		B	A51 Revised Proposed Exterior Brand Upgrade plans
1			Canopy Fascia Details

THESE ARE TRANSMITTED AS INDICATED BELOW

For your use As requested For your input For review & approval
 Other _____

Remarks:

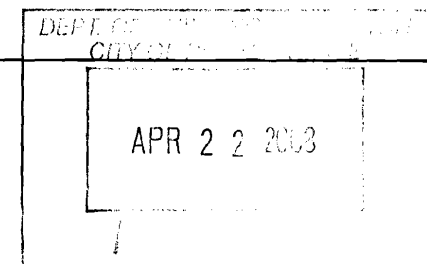

COPIES TO: _____

SIGNED: 
 Robert Schuler, PE

engineers • constructors • project managers • program managers

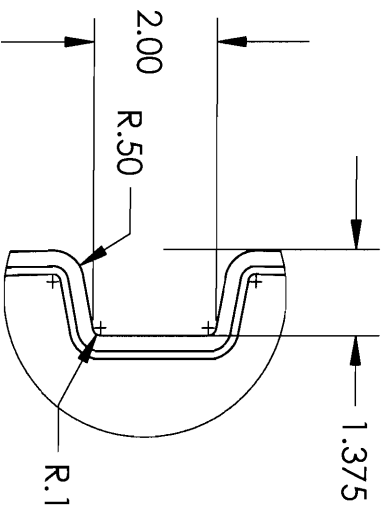
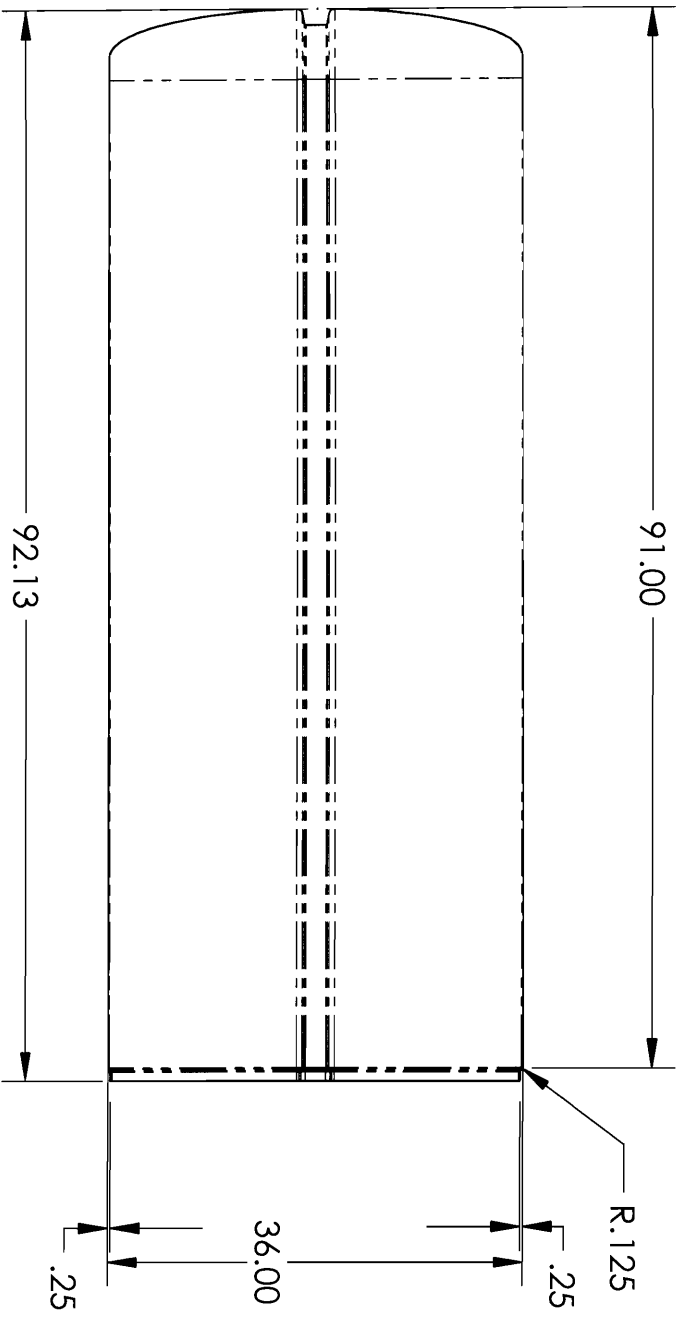
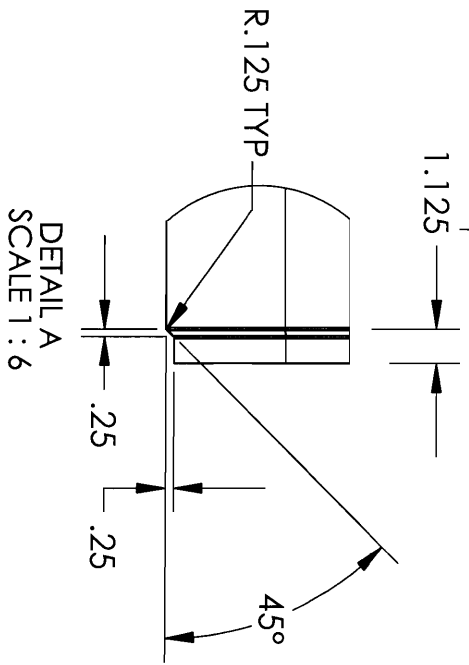
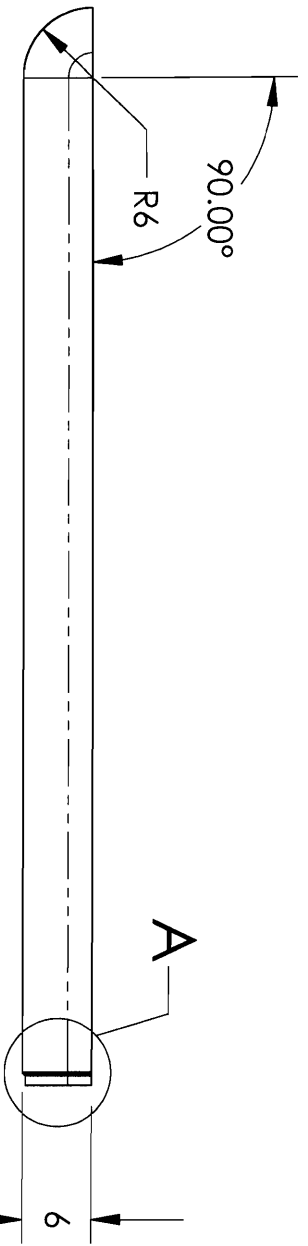

DETAIL B
SCALE 1:3

