



Reviewed for Code Compliance
Inspections Division
Approved with Conditions

Structural Design Report
188' 1800TLWD Guyed Tower
Site: Portland, ME

Date: 10/07/13

Prepared for: NORTHERN PRIDE COMMUNICATIONS INC
by: Sabre Towers & Poles™

Job Number: 90417

September 27, 2013

Tower Profile.....	1
Foundation Design Summary.....	2-3
Maximum Leg Loads and Face Shears.....	4
Maximum Deflections, Tilts, and Twists.....	5
Maximum Guy Tensions, Anchor Loads, and Base Loads.....	6
Calculations.....	7-21

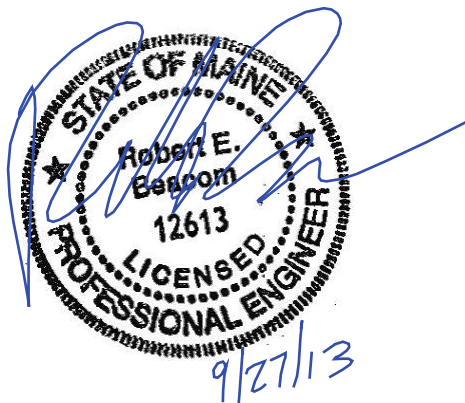



Reviewed for Code Compliance
Inspections Division
Approved with Conditions

Designed Appurtenance Loading

Elev	Description	
Base Reactions		
Total Foundation		Guy
Axial (kips)	55.18	Max Vertical (kips)
Shear (kips)	0.14	Max Horizontal (kips)

Notes

- 1) The tower model is 1800TLWD.
- 2) Lines are to be attached as shown on the cross-section drawing.
- 3) Guy lengths shown are not cut lengths.
- 4) Azimuths are relative (not based on true north).
- 5) See the Guy Tensions, Anchor Loads and Base Loads page(s) for maximum foundation loads.
- 6) Weights shown are estimates. Final weights may vary.
- 7) This tower was designed for a basic wind speed of 100 mph with 0" of radial ice, and 40 mph with 1" of radial ice, in accordance with ANSI/TIA-222-G, Structure Class II, Exposure Category C, Topographic Category 1.
- 8) Use 1.25" diameter (FY=50ksi) anchor rods.

Date: 10/07/13

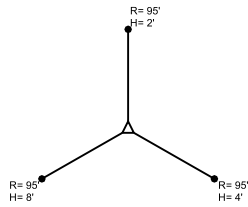

Legs	1,660 OD X .140	121
Diagonals	0.5 S.R.	136
Horizontals	0.5 S.R.	136
Brace Bolts	Welded Sections	136
Face Width	1.5'	142
Panel Count/Height	132 @ 1.4296'	136
Section Weight		136
		142
		136
		136
		142
		136
		136
		142
		136
		136
		142
		136
		136
		142

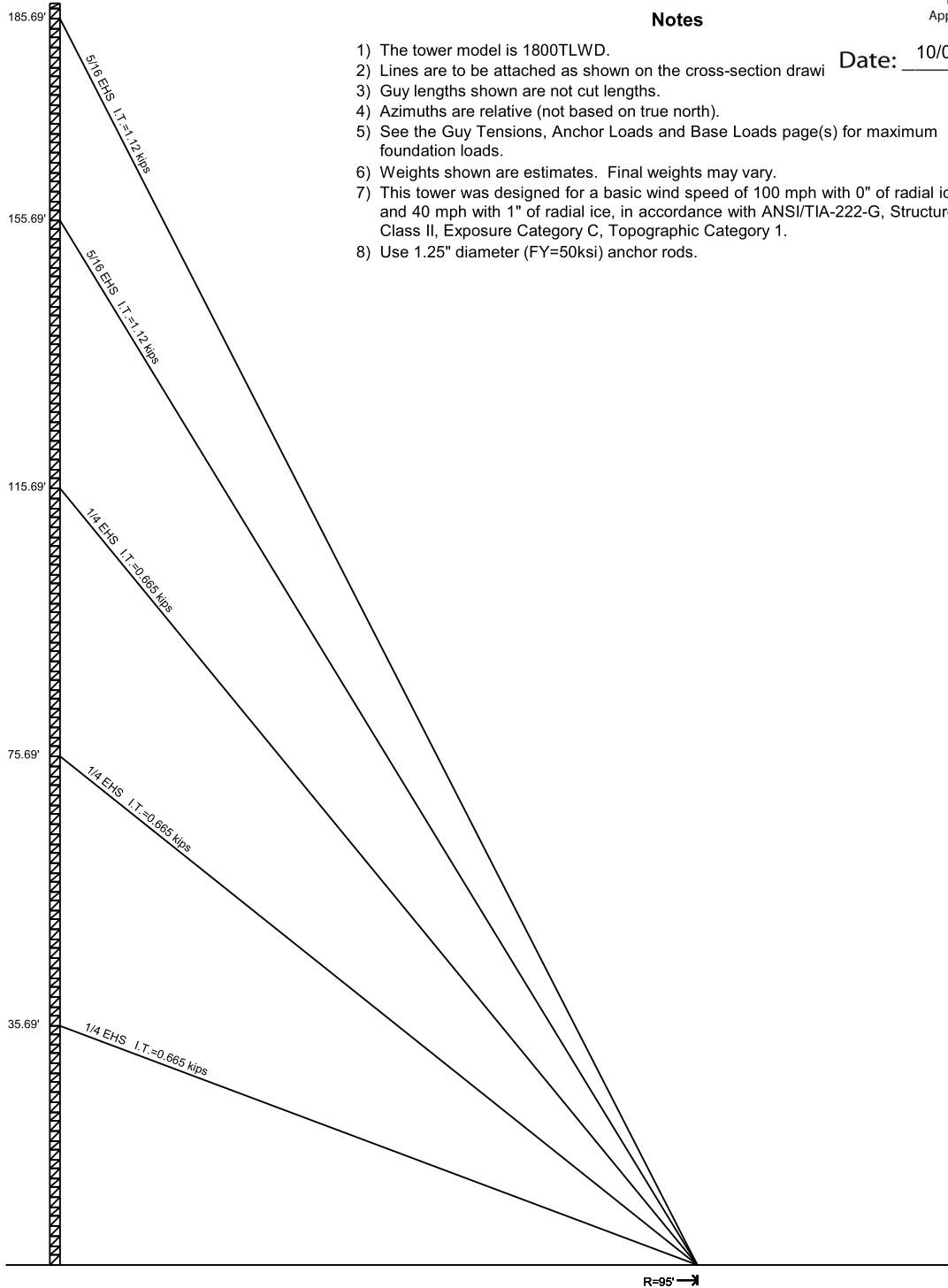

<p>Sabre Communications Corporation 2101 Murray Street P.O. Box 658 Sioux City, IA 51102-0658 Phone: (712) 258-6690 Fax: (712) 258-8290</p>	Job: 90417
	Customer: NORTHERN PRIDE COMMUNICATIONS INC
	Site Name: Portland, ME
	Description: 188' 1800TLWD
	Date: 9/27/2013 By: REB
<small>Information contained herein is the sole property of Sabre Communications Corporation, constitutes a trade secret as defined by Iowa Code Ch. 550 and shall not be reproduced, copied or used in whole or part for any purpose whatsoever without the prior written consent of Sabre Communications Corporation.</small>	

Customer: NORTHERN PRIDE COMMUNICATIONS INC
Site: Portland, ME

188 ft. Model 1800 SRWD Guyed Tower (18 in. face) At
100 mph Wind with no ice and 40 mph wind with 1 in. Ice per AN
Antenna Loading per Page 1

Date: 10/07/13

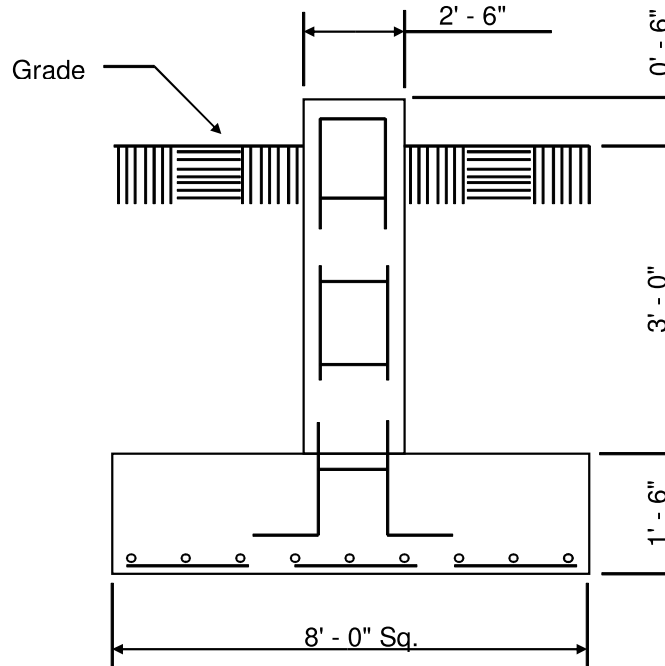

TOWER BASE

(4.19 Cu. Yds. Each)

(NOT TO SCALE)

Rebar Schedule	
PIER	(6) #7 vertical rebar w/ #3 ties @12" spacing
PAD	(9) #7 horizontal rebar Ea. Way Evenly Spaced Bottom Only

NOTES

- 1.) Concrete shall have a minimum 28 day compressive strength of 4000 PSI, in accordance with ACI 318-05.
- 2.) Rebar to conform to ASTM specification A615 Grade 60.
- 3.) All rebar to have a minimum of 3" concrete cover.
- 4.) All exposed concrete corners to be chamfered 3/4".
- 5.) The foundation design is based on the geotechnical report by S.W. Cole Engineering, Project No. 13-0993 S, Dated September 24, 2013.
- 6.) The foundation design is based on the following factored reactions:
Factored Axial load (kips) = 55.18
Factored Shear (kips) = 0.14
- 7.) See the geotechnical report for compaction requirements, if specified.

Customer: NORTHERN PRIDE COMMUNICATIONS INC

Site: Portland, ME

188 ft. Model 1800 SRWD Guyed Tower (18 in. face) At
100 mph Wind with no ice and 40 mph wind with 1 in. Ice per ANSI/
Antenna Loading per Page 1

Date: 10/07/13

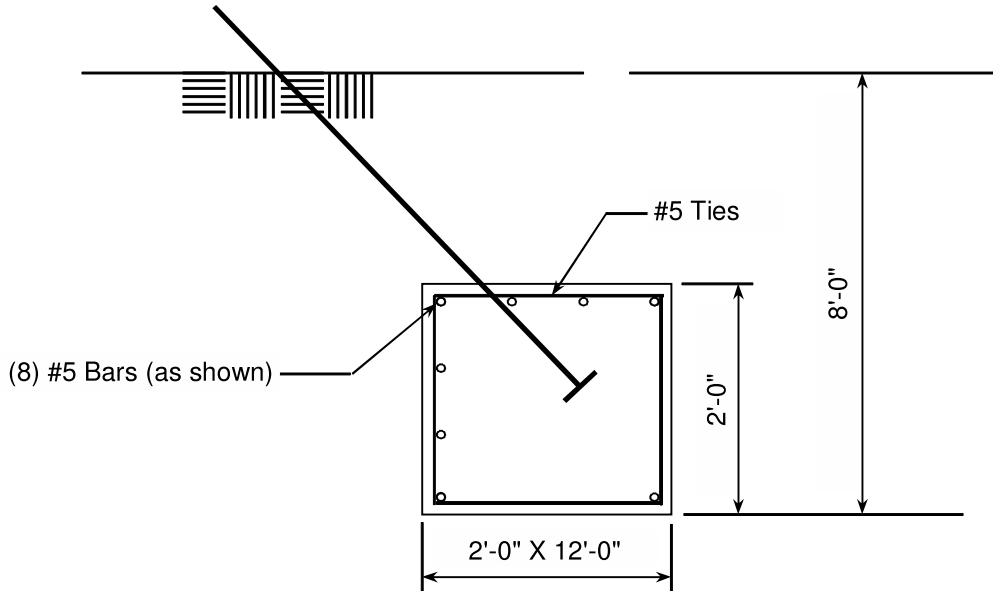

GUY ANCHOR

(1.78 Cu. Yds. Concrete)
(3 REQUIRED; NOT TO SCALE)

Rebar Schedule Per Anchor	
GUY ANCHOR	(8) #5 horizontal rebar X 11'-6" (13) #5 ties evenly spaced

NOTES

- 1.) Concrete shall have a minimum 28 day compressive strength of 4000 PSI, in accordance with ACI 318-05.
- 2.) Rebar to conform to ASTM specification A615 Grade 60.
- 3.) All rebar to have a minimum of 3" concrete cover.
- 4.) The foundation design is based on the geotechnical report by S.W. Cole Engineering, Project No. 13-0993 S, Dated September 24, 2013.
- 5.) The foundation design is based on the following factored reactions:
Uplift (kips) = 10.13
Horizontal force (kips) = 11.39
- 6.) When the soil electrical resistivity is less than 50 ohm-m and/or the measured soil pH values are below 3 or greater than 9, additional corrosion control is required. See the geotechnical report for these parameters and compaction requirements, if specified.



Reviewed for Code Compliance
Inspections Division
Approved with Conditions

Maximum

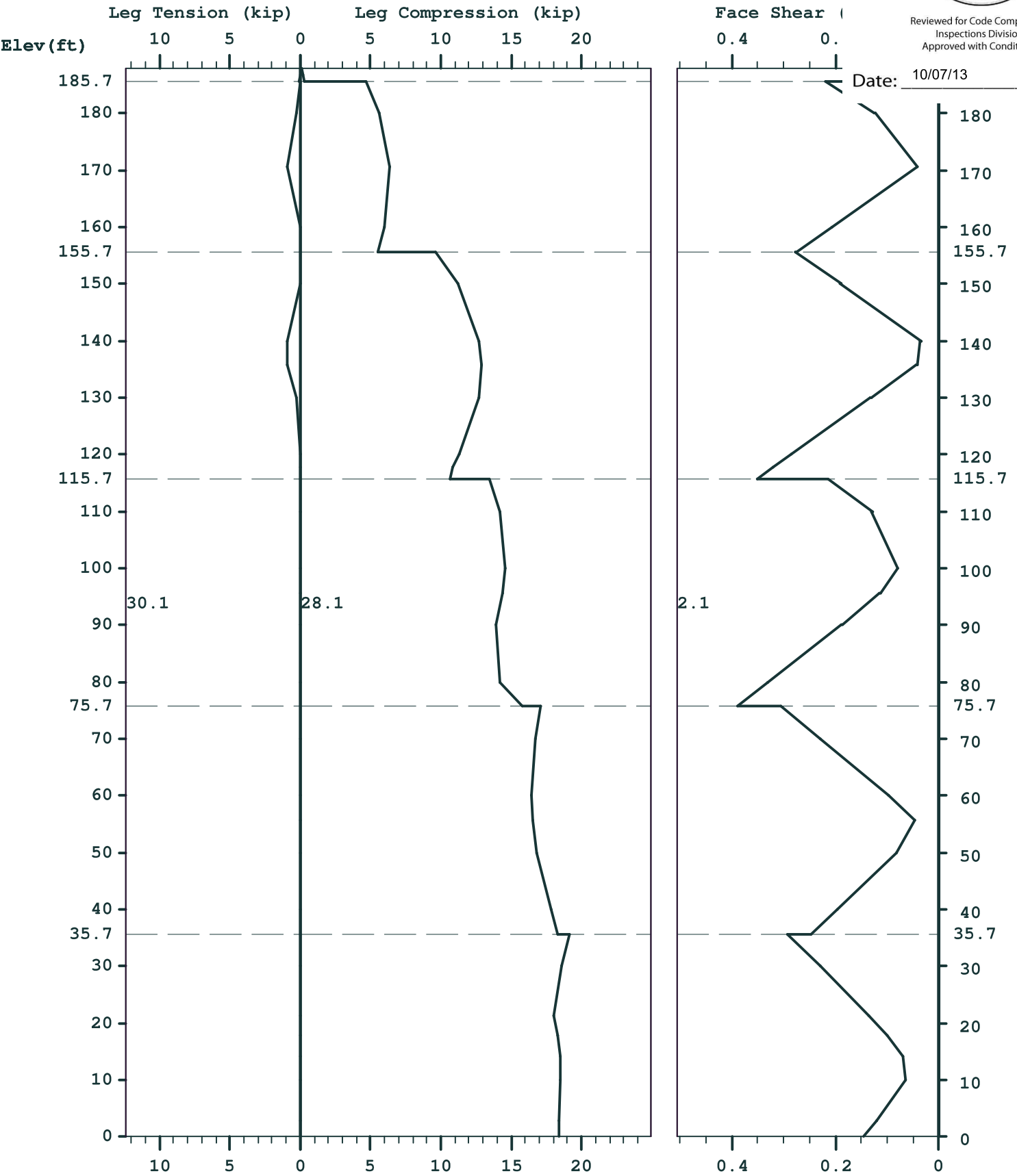



Maximum

Reviewed for Code Compliance
Inspections Division
Approved with Conditions

Date: 10/07/13

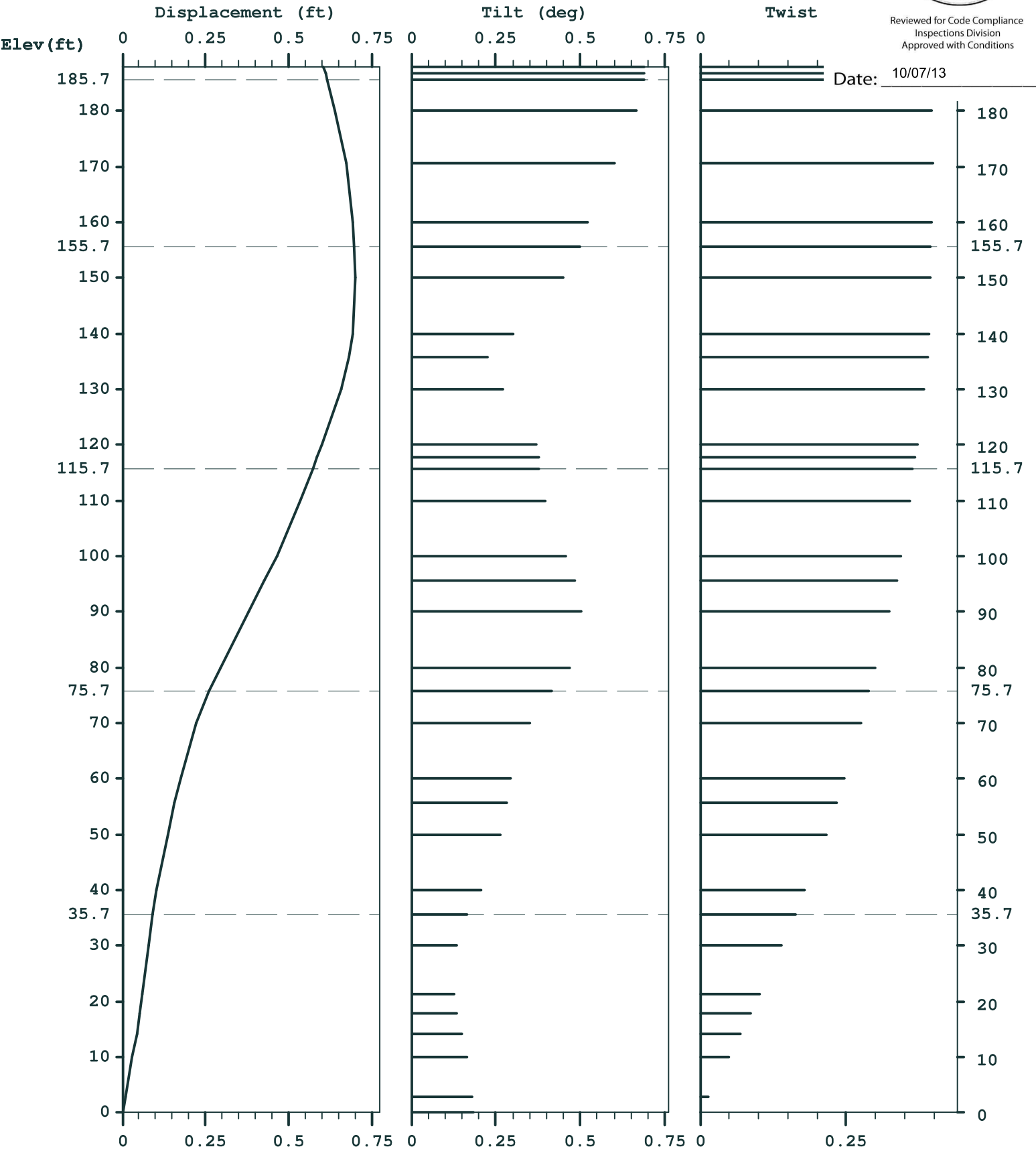



Reviewed for Code Compliance
 Inspections Division
 Approved with Conditions

Date: 10/07/13

Maximum

Guy Tensions, Anchor Loads and Base Loads

Maximum Values (kip)
 EFL/FR - The Effects Of Factored Loads Divided
 By The Factored Resistance

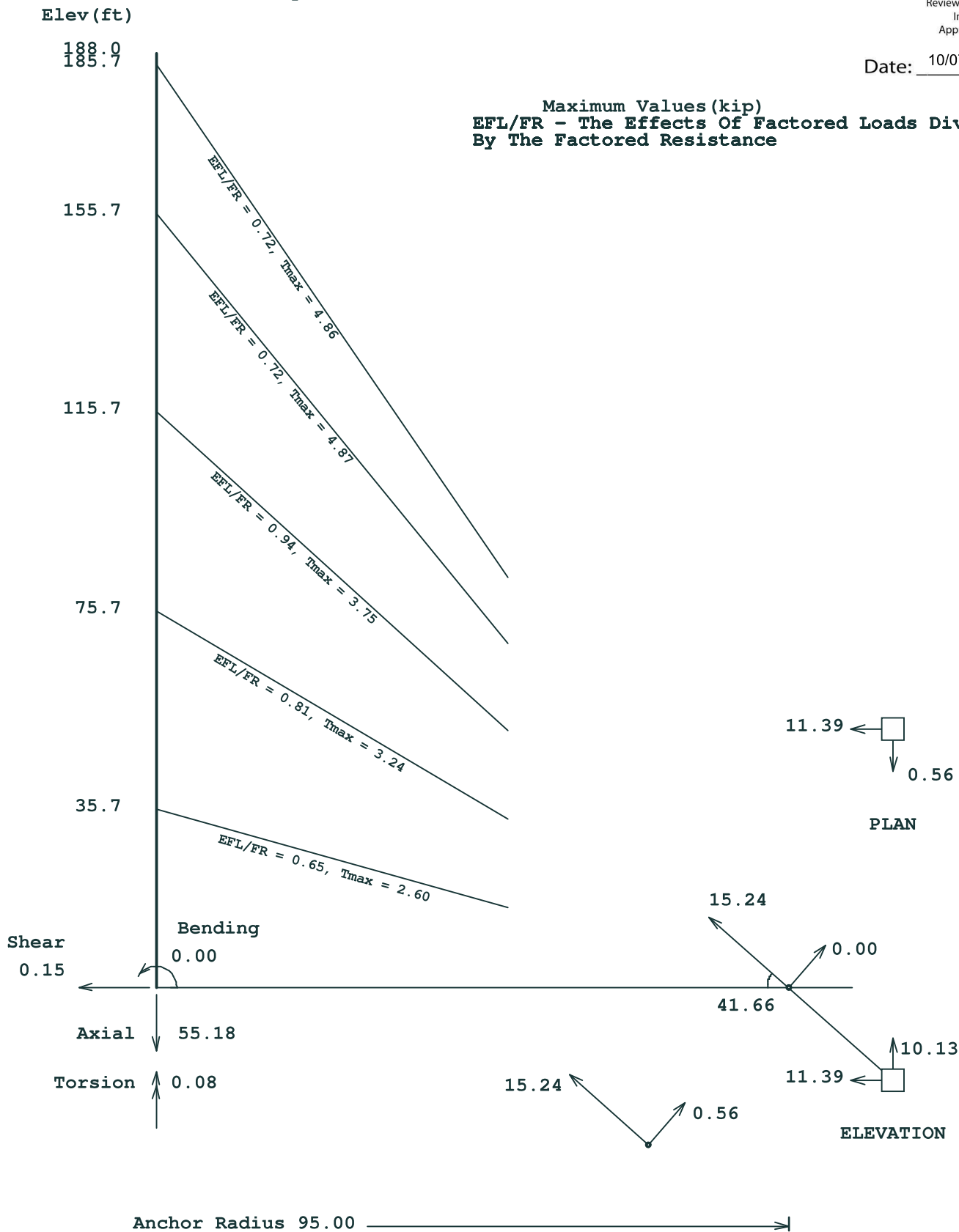

Processed under license at:

Sabre Communications Corporation

on: 25 sep 2013 at: 9:20:34



Reviewed for Code Compliance
Inspections Division
Approved with Conditions

Date: 10/07/13

MAST DATA

UPPER ELEV FT	MAST TYPE OF WEB	NO OF LEGS *	FACE WIDTH FT *	GEOM PANEL HEIGHT FT *	X-SECTION-AREA ONE LEG IN.SQ.	ONE DIAG IN.SQ. *	BARE WEIGHT K/FT.	ELASTIC MODULUS KIP/IN.SQ	TEMP COEFF /DEG
188.0	2	3	1.500	0.857	0.670	0.200	0.014	29000.0	0.0000117
187.1	2	3	1.500	1.429	0.670	0.200	0.012	29000.0	0.0000117
180.0	2	3	1.500	1.429	0.670	0.200	0.012	29000.0	0.0000117
170.0	2	3	1.500	1.429	0.670	0.200	0.012	29000.0	0.0000117
160.0	2	3	1.500	1.429	0.670	0.200	0.012	29000.0	0.0000117
150.0	2	3	1.500	1.429	0.670	0.200	0.012	29000.0	0.0000117
140.0	2	3	1.500	1.429	0.670	0.200	0.012	29000.0	0.0000117
130.0	2	3	1.500	1.429	0.670	0.200	0.012	29000.0	0.0000117
120.0	2	3	1.500	1.429	0.670	0.200	0.012	29000.0	0.0000117
110.0	2	3	1.500	1.429	0.670	0.200	0.012	29000.0	0.0000117
100.0	2	3	1.500	1.429	0.670	0.200	0.012	29000.0	0.0000117
90.0	2	3	1.500	1.429	0.670	0.200	0.012	29000.0	0.0000117
80.0	2	3	1.500	1.429	0.670	0.200	0.012	29000.0	0.0000117
70.0	2	3	1.500	1.429	0.670	0.200	0.012	29000.0	0.0000117
60.0	2	3	1.500	1.429	0.670	0.200	0.012	29000.0	0.0000117
50.0	2	3	1.500	1.429	0.670	0.200	0.012	29000.0	0.0000117
40.0	2	3	1.500	1.429	0.670	0.200	0.012	29000.0	0.0000117
30.0	2	3	1.500	1.429	0.670	0.200	0.012	29000.0	0.0000117
20.0	2	3	1.500	1.429	0.670	0.200	0.012	29000.0	0.0000117
10.0	2	3	1.500	1.429	0.670	0.200	0.012	29000.0	0.0000117

* If NO OF LEGS is 1 : that part of the mast is assumed to be cylindrical
and : FACE WIDTH = outside diameter
PANEL HEIGHT = thickness
AREA OF DIAG = Poisson ratio

GUY GEOMETRY

ELEV FT	GUY AZI DEG	DIAMETER IN.	HEIGHT FT.	RADIUS FT.	MAST ATTACH RADIUS FT.	ATTACH AZI DEG	INITIAL TENSION KIP
185.7	240.0	0.313	177.7	95.0	0.866	240.0	1.120
185.7	120.0	0.313	181.7	95.0	0.866	120.0	1.120
185.7	0.0	0.313	183.7	95.0	0.866	0.0	1.120
155.7	240.0	0.313	147.7	95.0	0.866	240.0	1.120
155.7	120.0	0.313	151.7	95.0	0.866	120.0	1.120
155.7	0.0	0.313	153.7	95.0	0.866	0.0	1.120



Reviewed for Code Compliance
 Inspections Division
 Approved with Conditions

Date: 10/07/13

90417.txt

115.7	240.0	0.250	107.7	95.0	0.866	240.0	0.670
115.7	120.0	0.250	111.7	95.0	0.866	120.0	0.670
115.7	0.0	0.250	113.7	95.0	0.866	0.0	0.670
75.7	240.0	0.250	67.7	95.0	0.866	240.0	0.670
75.7	120.0	0.250	71.7	95.0	0.866	120.0	0.670
75.7	0.0	0.250	73.7	95.0	0.866	0.0	0.670
35.7	240.0	0.250	27.7	95.0	0.866	240.0	0.670
35.7	120.0	0.250	31.7	95.0	0.866	120.0	0.670
35.7	0.0	0.250	33.7	95.0	0.866	0.0	0.670

GUY MATERIAL PROPERTIES

=====

ELEV FT	GUY AZI DEG	BREAKING STRENGTH KIP	GUY WEIGHT LBS/FT	GUY AREA IN. SQ	ELASTIC MODULUS KIP/IN. SQ	THERMAL COEFF /DEG	UNSTRESS LENGTH FT
185.7	240.0	11.230	0.222	0.059	21000.0	0.0000117	200.899
185.7	120.0	11.230	0.222	0.059	21000.0	0.0000117	204.437
185.7	0.0	11.230	0.222	0.059	21000.0	0.0000117	206.213
155.7	240.0	11.230	0.222	0.059	21000.0	0.0000117	174.980
155.7	120.0	11.230	0.222	0.059	21000.0	0.0000117	178.362
155.7	0.0	11.230	0.222	0.059	21000.0	0.0000117	180.062
115.7	240.0	6.650	0.129	0.038	21000.0	0.0000117	142.913
115.7	120.0	6.650	0.129	0.038	21000.0	0.0000117	145.945
115.7	0.0	6.650	0.129	0.038	21000.0	0.0000117	147.478
75.7	240.0	6.650	0.129	0.038	21000.0	0.0000117	115.848
75.7	120.0	6.650	0.129	0.038	21000.0	0.0000117	118.226
75.7	0.0	6.650	0.129	0.038	21000.0	0.0000117	119.447
35.7	240.0	6.650	0.129	0.038	21000.0	0.0000117	98.041
35.7	120.0	6.650	0.129	0.038	21000.0	0.0000117	99.243
35.7	0.0	6.650	0.129	0.038	21000.0	0.0000117	99.898

FACTORED LEG AND FACE SHEAR RESISTANCE

=====

BOTTOM ELEV ft	TOP ELEV ft	LEG COMP kip	FACE SHEAR kip	LEG TENS kip
0.00	10.00	28.12	2.08	30.10
10.00	20.00	28.12	2.08	30.10
20.00	30.00	28.12	2.08	30.10
30.00	40.00	28.12	2.08	30.10
40.00	50.00	28.12	2.08	30.10
50.00	60.00	28.12	2.08	30.10
60.00	70.00	28.12	2.08	30.10
70.00	80.00	28.12	2.08	30.10
80.00	90.00	28.12	2.08	30.10
90.00	100.00	28.12	2.08	30.10
100.00	110.00	28.12	2.08	30.10
110.00	120.00	28.12	2.08	30.10
120.00	130.00	28.12	2.08	30.10
130.00	140.00	28.12	2.08	30.10
140.00	150.00	28.12	2.08	30.10
150.00	160.00	28.12	2.08	30.10
160.00	170.00	28.12	2.08	30.10
170.00	180.00	28.12	2.08	30.10
180.00	188.00	28.12	2.08	30.10

* 12 wind directions were analyzed. Only 2 condition(s) shown in full

LOADING CONDITION A

100 mph wind with no ice. Wind Azimuth: 0°

MAST LOADING

=====

LOAD TYPE	ELEV FT	.FORCES (KIP & KIP/FT) N E DOWN			.MOMENTS (FT.K & FT.K/FT) N E TORSION			ANT-ORIENT AZI DEG	VERT DEG
C	188.0	-0.013	0.000	0.060	0.00	0.00	0.00	0.0	0.00
D	188.0	-0.026	0.000	0.016	0.00	0.00	0.00		
D	181.4	-0.024	0.000	0.013	0.00	0.00	0.00		
D	181.4	-0.024	0.000	0.014	0.00	0.00	0.00		
D	171.4	-0.024	0.000	0.014	0.00	0.00	0.00		



Reviewed for Code Compliance
 Inspections Division
 Approved with Conditions

Date: 10/07/13

90417.txt

D	171.4	-0.024	0.000	0.014	0.00	0.00	0.00
D	161.4	-0.024	0.000	0.014	0.00	0.00	0.00
D	161.4	-0.024	0.000	0.014	0.00	0.00	0.00
D	151.4	-0.024	0.000	0.014	0.00	0.00	0.00
D	151.4	-0.024	0.000	0.014	0.00	0.00	0.00
D	141.4	-0.023	0.000	0.014	0.00	0.00	0.00
D	141.4	-0.023	0.000	0.014	0.00	0.00	0.00
D	131.4	-0.023	0.000	0.014	0.00	0.00	0.00
D	131.4	-0.023	0.000	0.014	0.00	0.00	0.00
D	121.4	-0.023	0.000	0.014	0.00	0.00	0.00
D	121.4	-0.023	0.000	0.014	0.00	0.00	0.00
D	111.4	-0.022	0.000	0.014	0.00	0.00	0.00
D	111.4	-0.022	0.000	0.014	0.00	0.00	0.00
D	101.4	-0.022	0.000	0.014	0.00	0.00	0.00
D	101.4	-0.022	0.000	0.014	0.00	0.00	0.00
D	91.4	-0.021	0.000	0.014	0.00	0.00	0.00
D	91.4	-0.021	0.000	0.014	0.00	0.00	0.00
D	81.4	-0.021	0.000	0.014	0.00	0.00	0.00
D	81.4	-0.021	0.000	0.014	0.00	0.00	0.00
D	71.4	-0.020	0.000	0.014	0.00	0.00	0.00
D	71.4	-0.020	0.000	0.014	0.00	0.00	0.00
D	61.4	-0.020	0.000	0.014	0.00	0.00	0.00
D	61.4	-0.020	0.000	0.014	0.00	0.00	0.00
D	51.4	-0.019	0.000	0.014	0.00	0.00	0.00
D	51.4	-0.019	0.000	0.014	0.00	0.00	0.00
D	41.4	-0.018	0.000	0.014	0.00	0.00	0.00
D	41.4	-0.018	0.000	0.014	0.00	0.00	0.00
D	31.4	-0.017	0.000	0.014	0.00	0.00	0.00
D	31.4	-0.017	0.000	0.014	0.00	0.00	0.00
D	21.4	-0.016	0.000	0.014	0.00	0.00	0.00
D	21.4	-0.016	0.000	0.014	0.00	0.00	0.00
D	14.3	-0.015	0.000	0.014	0.00	0.00	0.00
D	14.3	-0.015	0.000	0.014	0.00	0.00	0.00
D	10.0	-0.015	0.000	0.014	0.00	0.00	0.00
D	10.0	-0.014	0.000	0.014	0.00	0.00	0.00
D	1.4	-0.014	0.000	0.014	0.00	0.00	0.00
D	1.4	-0.014	0.000	0.014	0.00	0.00	0.00
D	0.0	-0.014	0.000	0.014	0.00	0.00	0.00

GUY LOADING
 =====

.. WIND LOADING ...		TEMP	.ICE LOAD..		CONV	PROFILES.	.LOAD FACTORS.				
AZI	SPEED	REF	CHANGE	RAD	DENS	TOL	CAB	WIND	WIND	DEAD	ICE
DEG	MPH	PRESS	DEG	IN	PCF						
0.0	100.0	0.00	0.00	0.00	56.00	0.0100	2	4	1.60	1.00	1.00

CABLE PROFILE: 1 - CATENARY 2 - PARABOLIC

- WIND PROFILE: 1 - EIA 222 G default
 2 - Constant Kz=1, Kiz=1
 3 - Step function for Kz, Kiz
 (requires definition of Exposure Factor Kz, Kiz table)
 4 - Special Factors
 5 - Site specific wind formula, Kiz as EIA 222 G default
 (requires definition of Exposure Factor Qh formula table)

SUPPRESS PRINTING
 =====

INPUT LOADS	...FOR THIS LOADING..			MAXIMUMS.....			
	DISPL	INTRNL	MEMBER	LOADS	ALL	DISPL	INTRNL	MEMBER
	FORCES	FORCES	LOADS		FORCES	FORCES	LOADS	
	no	yes	yes	yes	no	no	no	no

SPECIAL FACTOR TABLE
 =====

ELEV	GUY	ATTACH	RADIAL	WIND	GUY	WIND	TEMP
	AZI	MAST	ICE	GUST	SHAPE	HEIGHT	CHANGE
FT	DEG	AZI	IN.	FACT	FACT	FACT	DEG
185.7	120.0	120.0	0.000	0.850	1.200	1.059	0.00
185.7	0.0	0.0	0.000	0.850	1.200	1.059	0.00
185.7	240.0	240.0	0.000	0.850	1.200	1.059	0.00
155.7	120.0	120.0	0.000	0.850	1.200	1.020	0.00



Reviewed for Code Compliance
 Inspections Division
 Approved with Conditions

Date: 10/07/13

90417.txt

155.7	0.0	0.0	0.000	0.850	1.200	1.020	0.00
155.7	240.0	240.0	0.000	0.850	1.200	1.020	0.00
115.7	120.0	120.0	0.000	0.850	1.200	0.959	0.00
115.7	0.0	0.0	0.000	0.850	1.200	0.959	0.00
115.7	240.0	240.0	0.000	0.850	1.200	0.959	0.00
75.7	120.0	120.0	0.000	0.850	1.200	0.877	0.00
75.7	0.0	0.0	0.000	0.850	1.200	0.877	0.00
75.7	240.0	240.0	0.000	0.850	1.200	0.877	0.00
35.7	120.0	120.0	0.000	0.850	1.200	0.748	0.00
35.7	0.0	0.0	0.000	0.850	1.200	0.748	0.00
35.7	240.0	240.0	0.000	0.850	1.200	0.748	0.00

=====
 LOADING CONDITION M =====
 40 mph wind with 1 ice. Wind Azimuth: 0°

MAST LOADING
 =====

LOAD TYPE	ELEV FT	.FORCES (KIP & KIP/FT)			.MOMENTS (FT.K & FT.K/FT)			ANT-ORIENT	
		N	E	DOWN	N	E	TORSION	AZI DEG	VERT DEG
C	188.0	-0.009	0.000	0.298	0.00	0.00	0.00	0.0	0.00
D	188.0	-0.019	0.000	0.146	0.00	0.01	0.00		
D	187.1	-0.019	0.000	0.146	0.00	0.01	0.00		
D	187.1	-0.015	0.000	0.114	0.00	0.01	0.00		
D	181.4	-0.015	0.000	0.114	0.00	0.01	0.00		
D	181.4	-0.015	0.000	0.114	0.00	0.01	0.00		
D	170.0	-0.015	0.000	0.113	0.00	0.01	0.00		
D	170.0	-0.015	0.000	0.112	0.00	0.01	0.00		
D	160.0	-0.015	0.000	0.112	0.00	0.01	0.00		
D	160.0	-0.014	0.000	0.112	0.00	0.01	0.00		
D	150.0	-0.014	0.000	0.111	0.00	0.01	0.00		
D	150.0	-0.014	0.000	0.110	0.00	0.01	0.00		
D	140.0	-0.014	0.000	0.110	0.00	0.01	0.00		
D	140.0	-0.014	0.000	0.109	0.00	0.01	0.00		
D	130.0	-0.014	0.000	0.108	0.00	0.01	0.00		
D	130.0	-0.014	0.000	0.108	0.00	0.01	0.00		
D	120.0	-0.013	0.000	0.107	0.00	0.01	0.00		
D	120.0	-0.013	0.000	0.107	0.00	0.01	0.00		
D	110.0	-0.013	0.000	0.106	0.00	0.01	0.00		
D	110.0	-0.013	0.000	0.105	0.00	0.01	0.00		
D	100.0	-0.013	0.000	0.104	0.00	0.01	0.00		
D	100.0	-0.012	0.000	0.104	0.00	0.01	0.00		
D	90.0	-0.012	0.000	0.103	0.00	0.01	0.00		
D	90.0	-0.012	0.000	0.102	0.00	0.01	0.00		
D	80.0	-0.012	0.000	0.101	0.00	0.01	0.00		
D	80.0	-0.012	0.000	0.100	0.00	0.00	0.00		
D	70.0	-0.011	0.000	0.099	0.00	0.01	0.00		
D	70.0	-0.011	0.000	0.098	0.00	0.00	0.00		
D	60.0	-0.011	0.000	0.097	0.00	0.00	0.00		
D	60.0	-0.011	0.000	0.096	0.00	0.00	0.00		
D	50.0	-0.010	0.000	0.094	0.00	0.00	0.00		
D	50.0	-0.010	0.000	0.094	0.00	0.00	0.00		
D	40.0	-0.010	0.000	0.092	0.00	0.00	0.00		
D	40.0	-0.009	0.000	0.091	0.00	0.00	0.00		
D	30.0	-0.009	0.000	0.088	0.00	0.00	0.00		
D	30.0	-0.009	0.000	0.087	0.00	0.00	0.00		
D	20.0	-0.008	0.000	0.083	0.00	0.00	0.00		
D	20.0	-0.007	0.000	0.082	0.00	0.00	0.00		
D	10.0	-0.007	0.000	0.077	0.00	0.00	0.00		
D	10.0	-0.007	0.000	0.075	0.00	0.00	0.00		
D	4.3	-0.007	0.000	0.071	0.00	0.01	0.00		
D	4.3	-0.007	0.000	0.069	0.00	0.01	0.00		
D	0.0	-0.007	0.000	0.060	0.00	0.01	0.00		

GUY LOADING
 =====

.. WIND LOADING ...			TEMP	.ICE LOAD..		CONV	PROFILES.		.LOAD FACTORS.		
AZI	SPEED	REF PRESS	CHANGE	RAD	DENS	TOL	CAB	WIND	WIND	DEAD	ICE
DEG	MPH	PSF	DEG	IN	PCF						
0.0	40.0	0.00	0.00	1.00	56.00	0.0100	2	4	1.00	1.00	1.00



Reviewed for Code Compliance
 Inspections Division
 Approved with Conditions

Date: 10/07/13

90417.txt
 CABLE PROFILE: 1 - CATENARY 2 - PARABOLIC
 WIND PROFILE: 1 - EIA 222 G default
 2 - Constant Kz=1, Kiz=1
 3 - Step function for Kz, Kiz
 (requires definition of Exposure Factor Kz, Kiz table)
 4 - Special Factors
 5 - Site specific wind formula, Kiz as EIA 222 G default
 (requires definition of Exposure Factor Qh formula table)

SUPPRESS PRINTING
 =====

INPUT LOADS	...FOR THIS LOADING..			MAXIMUMS.....			
	DISPL	INTRNL FORCES	MEMBER LOADS	ALL	DISPL	INTRNL FORCES	MEMBER LOADS	
	no	yes	yes	yes	no	no	no	no
SPECIAL FACTOR TABLE								
ELEV	GUY AZI	ATTACH MAST AZI	RADIAL ICE	WIND GUST FACT	GUY SHAPE FACT	WIND HEIGHT FACT	TEMP CHANGE DEG	
FT	DEG	DEG	IN.					
185.7	120.0	120.0	2.218	0.850	1.200	1.059	-10.00	
185.7	0.0	0.0	2.218	0.850	1.200	1.059	-10.00	
185.7	240.0	240.0	2.218	0.850	1.200	1.059	-10.00	
155.7	120.0	120.0	2.179	0.850	1.200	1.020	-10.00	
155.7	0.0	0.0	2.179	0.850	1.200	1.020	-10.00	
155.7	240.0	240.0	2.179	0.850	1.200	1.020	-10.00	
115.7	120.0	120.0	2.115	0.850	1.200	0.959	-10.00	
115.7	0.0	0.0	2.115	0.850	1.200	0.959	-10.00	
115.7	240.0	240.0	2.115	0.850	1.200	0.959	-10.00	
75.7	120.0	120.0	2.028	0.850	1.200	0.877	-10.00	
75.7	0.0	0.0	2.028	0.850	1.200	0.877	-10.00	
75.7	240.0	240.0	2.028	0.850	1.200	0.877	-10.00	
35.7	120.0	120.0	1.881	0.850	1.200	0.748	-10.00	
35.7	0.0	0.0	1.881	0.850	1.200	0.748	-10.00	
35.7	240.0	240.0	1.881	0.850	1.200	0.748	-10.00	

=====

MAXIMUM LEG LOADS AND FACE SHEARS (KIP - stress in KSI)

=====

MAST ELEV FT	MAX LEG LOADS					MAX FACE SHEARS		
	AXIAL	BENDING TENS	COMP	TOTAL TENS	COMP	TORSN	BEAM	TOTAL
188.00	0.1N	0.0W	0.0F	0.0A	0.10	0.0A	0.0H	0.0H
186.85	0.2N	0.0I	0.0K	0.0A	0.2W	0.0M	0.0H	0.0F
185.69	0.2M	0.1I	0.1K	0.0I	0.3W	0.0M	0.0L	0.0F
180.00	3.8M	0.9C	0.9M	0.0A	4.6M	0.0M	-0.2L	0.2L
170.69	4.0M	2.1C	1.8A	0.3C	5.6Q	0.0M	-0.1L	0.1L
160.00	4.0M	2.1C	1.8A	0.3C	5.6Q	0.0X	-0.1L	0.1L
155.69	4.4M	2.7C	2.2A	0.9C	6.4Q	0.0X	0.0E	0.0I
155.69	4.4M	2.7C	2.2A	0.9C	6.4Q	0.0N	0.0E	0.0E
155.69	4.8M	1.80	1.2Q	0.0A	5.9Q	0.0N	-0.2J	0.2F
155.69	4.8M	1.80	1.2Q	0.0A	5.9Q	0.0S	-0.2J	0.2F
155.69	4.9M	1.10	0.60	0.0A	5.50	0.0S	-0.3J	0.3F
155.69	8.2M	2.20	1.5Q	0.0A	9.7Q	0.0X	-0.3H	0.3F



Reviewed for Code Compliance
 Inspections Division
 Approved with Conditions

Date: 10/07/13

90417.txt

150.00	8.4M	3.70	2.8M	0.0A	11.2M	0.0D	-0.2H	0.2H
	8.4M	3.70	2.8M	0.0A	11.2M	0.0D	-0.2H	0.2H
140.00	8.8M	5.20	3.9M	1.0C	12.7M	0.0N	0.0W	0.0H
	8.8M	5.20	3.9M	1.0C	12.7M	0.0N	0.0W	0.0H
135.69	8.9M	5.30	4.0M	0.9C	12.9M	0.0N	0.0D	0.0A
	8.9M	5.30	4.0M	0.9C	12.9M	0.0N	0.0D	0.0A
130.00	9.1M	4.90	3.6M	0.3C	12.7M	0.0N	0.1D	0.1L
	9.1M	4.90	3.6M	0.3C	12.7M	0.0N	0.1D	0.1L
120.00	9.5M	3.10	1.8X	0.0A	11.3X	0.0S	0.3D	0.3L
	9.5M	3.10	1.8X	0.0A	11.3X	0.0S	0.3D	0.3L
117.72	9.6M	2.50	1.30	0.0A	10.90	0.0S	0.3D	0.3L
	9.6M	2.50	1.30	0.0A	10.90	0.0S	0.3D	0.3L
115.69	9.7M	1.80	1.00	0.0A	10.60	0.0S	0.3D	0.4L
	12.00	2.60	1.4X	0.0A	13.40	0.0N	0.2J	0.2J
110.00	12.20	3.30	2.0X	0.0A	14.2X	0.0N	0.1I	0.1J
	12.20	3.30	2.0X	0.0A	14.2X	0.0N	0.1I	0.1H
100.00	12.60	3.30	2.0X	0.0A	14.6N	0.0N	0.10	0.1S
	12.60	3.30	2.0X	0.0A	14.6N	0.0N	0.10	0.1S
95.69	12.70	2.8S	1.7X	0.0A	14.4N	0.0N	0.1P	0.1S
	12.70	2.8S	1.7X	0.0A	14.4N	0.0N	0.1P	0.1S
90.00	12.90	1.8S	1.00	0.0A	13.90	0.0N	-0.2B	0.2L
	12.90	1.8S	1.00	0.0A	13.90	0.0N	-0.2B	0.2L
80.00	13.30	2.4E	2.7C	0.0A	14.20	0.0N	-0.3B	0.3L
	13.30	2.4E	2.7C	0.0A	14.20	0.0N	-0.3B	0.3L
75.69	13.40	4.0A	4.5C	0.0A	15.80	0.0N	-0.4B	0.4L
	15.20	3.4E	3.9C	0.0A	17.10	0.0N	0.3J	0.3H
70.00	15.40	1.9E	2.5C	0.0A	16.70	0.0N	0.2J	0.2H
	15.40	1.9E	2.5C	0.0A	16.70	0.0N	0.2J	0.2H
60.00	15.70	0.7M	1.1C	0.0A	16.40	0.0N	0.1J	0.1H
	15.70	0.7M	1.1C	0.0A	16.40	0.0N	0.1J	0.1H
55.69	15.90	0.6M	0.9C	0.0A	16.50	0.0N	0.0I	0.0T
	15.90	0.6M	0.9C	0.0A	16.50	0.0N	0.0I	0.0T
50.00	16.00	0.6H	1.1G	0.0A	16.80	0.0N	-0.1G	0.1G
	16.00	0.6H	1.1G	0.0A	16.80	0.0N	-0.1G	0.1G
40.00	16.40	1.4L	2.5G	0.0A	17.80	0.0N	0.2L	0.2L
	16.40	1.4L	2.5G	0.0A	17.80	0.0N	0.2L	0.2L
35.69	16.50	2.2A	3.4G	0.0A	18.40	0.0N	0.2L	0.2L
	17.40	2.0A	3.3G	0.0A	19.10	0.0N	-0.3L	0.3B
30.00	17.60	0.9K	1.7G	0.0A	18.60	0.0N	-0.2L	0.2B
	17.60	0.9K	1.7G	0.0A	18.60	0.0N	-0.2L	0.2B
21.43	17.90	0.5H	0.7I	0.0A	18.00	0.1N	-0.1L	0.1B
	17.90	0.5H	0.7I	0.0A	18.00	0.1N	-0.1L	0.1B
	18.00	0.5E	1.0I	0.0A	18.3U	0.1N	0.1G	0.1B



Reviewed for Code Compliance
 Inspections Division
 Approved with Conditions

Date: 10/07/13

90417.txt

17.84	18.00	0.5E	1.0I	0.0A	18.3U	0.1N	0.1G	0.1B
	18.10	0.6J	1.1I	0.0A	18.5U	0.1N	0.0G	0.1N
14.28	18.10	0.6J	1.1I	0.0A	18.5U	0.1N	0.0G	0.1N
	18.20	0.6C	1.0I	0.0A	18.5Q	0.1N	0.0I	0.1H
10.00	18.20	0.6C	1.0I	0.0A	18.5Q	0.1N	0.0I	0.1H
	18.30	0.3C	0.4I	0.0A	18.4N	0.1N	-0.1I	0.1A
2.86	18.30	0.3C	0.4I	0.0A	18.4N	0.1N	-0.1I	0.1A
	18.40	0.0M	0.0B	0.0A	18.4O	0.1N	-0.1J	0.1A
0.00								

CAPACITY RATIO TABLE

MAST ELEV FT	LEG LOAD		COMP/ CAP RATIO	FACE SHEAR		COMP/ CAP RATIO
	MAX COMP	COMP CAP		MAX FACE SHEAR	FACE SHEAR CAP	
188.00	0.10	28.12	0.00	0.01	2.08	0.00
	0.18	28.12	0.01	0.03	2.08	0.01
186.85	0.18	28.12	0.01	0.03	2.08	0.01
	0.26	28.12	0.01	0.05	2.08	0.02
185.69	4.64	28.12	0.16	0.22	2.08	0.11
	5.63	28.12	0.20	0.13	2.08	0.06
180.00	5.63	28.12	0.20	0.12	2.08	0.06
	6.41	28.12	0.23	0.04	2.08	0.02
170.69	6.41	28.12	0.23	0.04	2.08	0.02
	6.38	28.12	0.23	0.05	2.08	0.03
170.00	6.38	28.12	0.23	0.05	2.08	0.03
	5.95	28.12	0.21	0.21	2.08	0.10
160.00	5.95	28.12	0.21	0.21	2.08	0.10
	5.53	28.12	0.20	0.28	2.08	0.13
155.69	9.67	28.12	0.34	0.28	2.08	0.13
	11.18	28.12	0.40	0.19	2.08	0.09
150.00	11.18	28.12	0.40	0.19	2.08	0.09
	12.72	28.12	0.45	0.04	2.08	0.02
140.00	12.72	28.12	0.45	0.04	2.08	0.02
	12.91	28.12	0.46	0.04	2.08	0.02
135.69	12.91	28.12	0.46	0.04	2.08	0.02
	12.71	28.12	0.45	0.13	2.08	0.06
130.00	12.71	28.12	0.45	0.13	2.08	0.06
	11.28	28.12	0.40	0.29	2.08	0.14
120.00	11.28	28.12	0.40	0.29	2.08	0.14
	10.87	28.12	0.39	0.32	2.08	0.15
117.72	10.87	28.12	0.39	0.32	2.08	0.15
	10.64	28.12	0.38	0.35	2.08	0.17
115.69	13.43	28.12	0.48	0.21	2.08	0.10
	14.18	28.12	0.50	0.13	2.08	0.06
110.00	14.18	28.12	0.50	0.13	2.08	0.06
	14.58	28.12	0.52	0.08	2.08	0.04
100.00	14.58	28.12	0.52	0.08	2.08	0.04
	14.39	28.12	0.51	0.11	2.08	0.05
95.69	14.39	28.12	0.51	0.11	2.08	0.06
	13.92	28.12	0.50	0.19	2.08	0.09
90.00	13.92	28.12	0.50	0.19	2.08	0.09
	14.21	28.12	0.51	0.33	2.08	0.16
80.00	14.21	28.12	0.51	0.33	2.08	0.16



Reviewed for Code Compliance
 Inspections Division
 Approved with Conditions

Date: 10/07/13

90417.txt

75.69	15.80	28.12	0.56	0.39	2.08	0.19
	17.13	28.12	0.61	0.30	2.08	0.15
	16.71	28.12	0.59	0.23	2.08	0.11
70.00						
	16.71	28.12	0.59	0.23	2.08	0.11
	16.44	28.12	0.58	0.10	2.08	0.05
60.00						
	16.44	28.12	0.58	0.10	2.08	0.05
	16.53	28.12	0.59	0.05	2.08	0.02
55.69						
	16.53	28.12	0.59	0.05	2.08	0.02
	16.82	28.12	0.60	0.08	2.08	0.04
50.00						
	16.82	28.12	0.60	0.08	2.08	0.04
	17.79	28.12	0.63	0.20	2.08	0.09
40.00						
	17.79	28.12	0.63	0.20	2.08	0.09
	18.35	28.12	0.65	0.25	2.08	0.12
35.69						
	19.14	28.12	0.68	0.29	2.08	0.14
	18.60	28.12	0.66	0.23	2.08	0.11
30.00						
	18.60	28.12	0.66	0.23	2.08	0.11
	18.05	28.12	0.64	0.14	2.08	0.07
21.43						
	18.05	28.12	0.64	0.14	2.08	0.07
	18.14	28.12	0.65	0.12	2.08	0.06
20.00						
	18.14	28.12	0.65	0.12	2.08	0.06
	18.28	28.12	0.65	0.10	2.08	0.05
17.84						
	18.28	28.12	0.65	0.10	2.08	0.05
	18.45	28.12	0.66	0.07	2.08	0.03
14.28						
	18.45	28.12	0.66	0.07	2.08	0.03
	18.54	28.12	0.66	0.06	2.08	0.03
10.00						
	18.54	28.12	0.66	0.06	2.08	0.03
	18.44	28.12	0.66	0.12	2.08	0.06
2.86						
	18.44	28.12	0.66	0.12	2.08	0.06
	18.39	28.12	0.65	0.14	2.08	0.07
0.00						

MAXIMUM MAST DEFORMATION CALCULATED
 =====

MAST ELEV FT	DEFLECTIONS (FT)				ROTATIONS (DEG)			TWIST
	NORTH	EAST	TOTAL	DOWN	NORTH	EAST	TOTAL	
188.0	0.59G	-0.57D	0.61C	0.090	-0.69S	0.580	0.69S	-0.39N
186.8	0.60G	-0.58D	0.61C	0.090	-0.69S	0.580	0.69S	-0.39N
185.7	0.60G	-0.58D	0.62C	0.090	-0.69S	0.580	0.69S	-0.39N
180.0	0.63G	-0.60D	0.64C	0.090	-0.67S	0.560	0.67S	-0.40N
170.7	0.66G	-0.62D	0.67C	0.090	-0.60S	0.500	0.60S	-0.40N
160.0	0.68G	-0.63D	0.69C	0.090	-0.52S	0.430	0.52S	-0.40N
155.7	0.69G	-0.63D	0.70C	0.090	-0.50S	0.410	0.50S	-0.39N
150.0	0.70G	-0.63D	0.70C	0.080	-0.45S	0.360	0.45S	-0.39N
140.0	0.69G	-0.62D	0.69C	0.080	-0.30S	0.230	0.30S	-0.39N
135.7	0.68G	-0.61D	0.68C	0.080	-0.23S	-0.19D	0.23S	-0.39N
130.0	0.66G	-0.59D	0.66C	0.080	0.26G	-0.26D	0.27K	-0.38N
120.0	0.60G	-0.53D	0.60C	0.070	0.36G	-0.34D	0.37C	-0.37N
117.7	0.59G	-0.52D	0.59C	0.070	0.37G	-0.34D	0.38C	-0.37N
115.7	0.57G	-0.51D	0.57G	0.070	0.37G	-0.33D	0.38C	-0.36N
110.0	0.54G	-0.47D	0.54G	0.070	0.39G	-0.34C	0.40C	-0.36N
100.0	0.46G	-0.41D	0.46G	0.060	0.45G	-0.39C	0.46C	-0.34N
95.7	0.43G	-0.38D	0.43G	0.060	0.48G	-0.42C	0.48C	-0.34N
90.0	0.38G	-0.34D	0.38G	0.060	0.50G	-0.43C	0.50C	-0.32N



Reviewed for Code Compliance
 Inspections Division
 Approved with Conditions

Date: 10/07/13

90417.txt

80.0	0.29G	-0.26D	0.29G	0.050	0.47G	-0.40C	0.47G	-0.30N
75.7	0.26G	-0.24D	0.26G	0.050	0.41G	-0.35C	0.41G	-0.29N
70.0	0.22G	-0.21D	0.22G	0.050	0.35G	-0.30C	0.35G	-0.28N
60.0	-0.17A	-0.16D	0.170	0.040	0.30G	-0.25C	0.30G	-0.25N
55.7	-0.16A	-0.15D	0.16A	0.040	0.28G	-0.23C	0.28G	-0.23N
50.0	-0.14A	-0.12D	0.14A	0.040	0.26G	-0.22D	0.26G	-0.22N
40.0	-0.10A	-0.09D	0.10A	0.030	0.21G	-0.18D	0.21G	-0.18N
35.7	-0.09A	-0.08E	0.09A	0.030	0.16G	-0.15D	0.170	-0.16N
30.0	-0.08A	-0.06E	0.08A	0.020	-0.12A	-0.12P	0.140	-0.14N
21.4	-0.06A	-0.05E	0.06A	0.020	-0.13A	-0.11P	0.13A	-0.10N
17.8	-0.05A	-0.04E	0.05A	0.010	-0.14A	-0.11E	0.14A	-0.09N
14.3	-0.04A	-0.04E	0.04A	0.010	-0.15A	-0.12E	0.15A	-0.07N
10.0	-0.03A	-0.03E	0.03A	0.010	-0.16A	-0.14E	0.16A	-0.05N
2.9	-0.01A	-0.01E	0.01A	0.000	-0.18A	-0.15E	0.18A	-0.01N
0.0	0.00A	0.00A	0.00A	0.00A	-0.18A	-0.16E	0.18A	0.00A

MAXIMUM ANTENNA ROTATIONS

ELEV FT	ORIENTATION	 BEAM DEFLECTIONS (DEG)		 TOTAL
	AZI DEG	ELEV DEG	ROLL	YAW	PITCH	
188.0	0.0	0.0	-0.583 O	0.392 T	0.690 S	0.752 S

MAXIMUM INTERNAL MAST FORCES

MAST ELEV FT	TOTAL AXIAL KIPSHEAR.....	MOMENT.....		TORSION FT-KIP
		N - S KIP	E - W KIP	N - S FT-KIP	E - W FT-KIP	
188.0	0.30 N	-0.01 A	0.01 J	0.00 F	0.00 U	0.00 A
186.8	0.46 N	-0.04 A	0.04 J	0.03 A	-0.03 J	0.00 M
	0.46 N	0.04 G	0.04 J	0.03 A	-0.03 J	0.00 M
	0.59 M	0.07 G	0.07 J	0.10 A	-0.10 J	0.00 M
185.7	* 10.77 M	+ -0.40 G	+ -0.38 J	& -1.21 M	& -1.17 D	@ 0.02 M
	11.36 M	-0.34 G	0.32 D	-1.11 M	-1.10 P	0.01 M
180.0	12.01 M	-0.20 G	0.18 D	2.64 G	-2.53 D	0.01 M
	12.01 M	-0.20 G	0.18 D	2.64 G	-2.53 D	0.01 X
170.7	13.07 M	-0.07 A	-0.06 E	3.49 G	-3.17 D	0.00 X
	13.07 M	-0.07 A	-0.06 E	3.49 G	-3.17 D	0.00 N
160.0	14.26 M	-0.33 A	0.31 J	2.28 S	-2.05 O	-0.01 N
	14.26 M	-0.33 A	0.31 J	2.28 S	-2.05 O	0.01 S
	14.74 M	-0.43 A	0.41 J	1.46 S	-1.32 O	0.01 S
155.7	* 9.86 M	+ 0.87 A	+ -0.85 J	& -1.62 A	& -1.55 D	@ 0.02 M
	24.61 M	-0.41 G	-0.41 J	2.61 S	-2.46 O	0.01 X
150.0	25.24 M	-0.28 G	-0.27 J	4.60 S	-4.18 O	0.01 D
	25.24 M	-0.28 G	-0.27 J	4.60 S	-4.18 O	0.01 D
140.0	26.34 M	-0.05 G	-0.04 W	6.50 S	-5.80 O	-0.01 N
	26.34 M	-0.05 S	-0.04 W	6.50 S	-5.80 O	-0.01 N



Reviewed for Code Compliance
 Inspections Division
 Approved with Conditions

Date: 10/07/13

90417.txt

135.7	26.81 M	-0.06 A	-0.06 D	6.66 S	-5.92 O	-0.01 N
	26.81 M	-0.06 A	-0.06 D	6.66 S	-5.92 O	-0.01 N
130.0	27.43 M	-0.19 A	-0.19 D	6.24 S	-5.53 O	-0.02 N
	27.43 M	-0.19 A	-0.19 D	6.24 S	-5.53 O	-0.02 N
120.0	28.50 M	-0.42 A	-0.42 D	3.89 S	-3.42 O	0.02 S
	28.50 M	-0.42 A	-0.42 D	3.89 S	-3.42 O	0.02 S
117.7	28.75 M	-0.47 A	-0.47 D	3.09 S	-2.71 O	0.03 S
	28.75 M	-0.47 A	-0.47 D	3.09 S	-2.71 O	0.03 S
	28.96 M	-0.52 A	-0.52 D	2.30 S	-2.01 O	0.03 S
115.7	* 7.16 O	+ 0.89 A	+ -0.87 J	& -1.10 A	& -1.05 D	@ -0.02 R
	36.09 O	0.32 A	-0.30 J	3.16 S	-2.85 O	-0.02 N
110.0	36.69 O	0.20 A	-0.18 I	4.13 S	-3.64 O	-0.02 N
	36.69 O	0.20 A	-0.18 I	4.13 S	-3.64 O	-0.02 N
100.0	37.74 O	0.10 S	-0.10 O	4.24 S	-3.64 O	-0.03 N
	37.74 O	0.10 S	-0.10 O	4.24 S	-3.64 O	-0.03 N
95.7	38.19 O	0.17 G	-0.15 P	3.68 S	-3.10 O	-0.03 N
	38.19 O	0.17 G	-0.15 P	3.68 S	-3.10 O	-0.03 N
90.0	38.77 O	0.29 G	-0.26 D	2.40 S	-1.94 O	-0.03 N
	38.77 O	0.29 G	-0.26 D	2.40 S	-1.94 O	-0.04 N
80.0	39.79 O	0.50 G	-0.47 D	-3.36 G	3.34 D	-0.04 N
	39.79 O	0.50 G	-0.47 D	-3.36 G	3.34 D	-0.04 N
	40.22 O	0.58 G	-0.56 D	-5.69 G	5.54 D	-0.04 N
75.7	* 5.43 O	+ -0.96 G	+ 0.95 D	& -0.73 A	& -0.70 D	@ -0.02 R
	45.65 O	0.43 A	-0.43 J	-5.00 G	4.85 D	-0.04 N
70.0	46.21 O	0.31 A	-0.31 J	-3.18 G	2.88 D	-0.04 N
	46.21 O	0.31 A	-0.31 J	-3.18 G	2.88 D	-0.04 N
60.0	47.19 O	0.12 A	-0.11 J	-1.39 G	1.22 C	-0.04 N
	47.19 O	0.12 A	-0.11 J	-1.39 G	1.22 C	-0.05 N
55.7	47.60 O	0.03 A	-0.04 I	-1.18 G	1.01 C	-0.05 N
	47.60 O	0.03 A	-0.04 I	-1.18 G	1.01 C	-0.05 N
50.0	48.14 O	0.10 G	-0.08 D	-1.42 G	1.18 C	-0.05 N
	48.14 O	0.10 G	-0.08 D	-1.42 G	1.18 C	-0.05 N
40.0	49.07 O	0.28 G	-0.26 D	-3.20 G	2.67 C	-0.06 N
	49.07 O	0.28 G	-0.26 D	-3.20 G	2.67 C	-0.06 N
	49.46 O	0.36 G	-0.34 D	-4.46 G	3.73 C	-0.06 N
35.7	* 2.88 O	+ -0.72 G	+ 0.69 D	& -0.25 A	& -0.23 D	@ 0.02 X
	52.33 O	-0.41 G	0.38 D	-4.25 G	3.53 C	-0.06 N
30.0	52.84 O	-0.31 G	0.28 D	-2.27 G	1.84 C	-0.06 N
	52.84 O	-0.31 G	0.28 D	-2.27 G	1.84 C	-0.06 N
21.4	53.57 O	-0.17 G	0.14 D	-0.87 A	0.85 I	-0.07 N
	53.57 O	-0.17 G	0.14 D	-0.87 A	0.85 I	-0.07 N



Reviewed for Code Compliance
 Inspections Division
 Approved with Conditions

Date: 10/07/13

90417.txt

17.8	53.87 o	-0.11 G	-0.09 K	-1.23 A	1.15 I	-0.07 N
	53.87 o	-0.11 G	-0.09 K	-1.23 A	1.15 I	-0.07 N
14.3	54.15 o	-0.06 G	-0.05 K	-1.38 A	1.26 I	-0.07 N
	54.15 o	-0.06 G	-0.05 K	-1.38 A	1.26 I	-0.07 N
10.0	54.49 o	-0.05 A	0.05 I	-1.30 A	1.17 I	-0.07 N
	54.49 o	-0.05 A	0.05 I	-1.30 A	1.17 I	-0.07 N
2.9	55.00 o	-0.15 A	0.14 I	-0.52 A	0.47 I	-0.08 N
	55.00 o	-0.15 A	0.14 I	-0.52 A	0.47 I	-0.08 N
	55.18 o	-0.19 A	0.18 J	0.00 M	0.00 U	-0.08 N
base reaction	55.18 o	0.15 A	-0.14 J	0.00 M	0.00 E	0.08 N

* VERTICAL GUY LOAD & GUY ECCENTRIC MOMENT
 + HORIZONTAL REACTION @ TORSIONAL RESISTANCE

MAXIMUM GUY FORCES AT MAST

GUY LEVEL FT	GUY AZI	COMPONENTS AT MAST			TOTAL	EFL/FR * RATIO	...GUY ANGLES...	
		N KIP	E KIP	DOWN KIP	KIP		VERT DEG	HORIZ DEG
185.7	0.0	1.8M	0.2V	4.5M	4.9M	0.7M	-68.4M	-7.8E
	120.0	-0.9P	1.6Q	4.5Q	4.8Q	0.7Q	-68.2R	7.8A
	240.0	-0.9V	-1.6U	4.4U	4.8U	0.7U	-67.7T	-7.6A
155.7	0.0	2.2M	0.1V	4.4M	4.9M	0.7M	-63.6W	-7.0E
	120.0	-1.1P	1.9Q	4.3Q	4.8Q	0.7Q	-63.3S	7.0A
	240.0	-1.1V	-1.9U	4.2U	4.7U	0.7U	-62.7S	-6.9A
115.7	0.0	2.1M	0.1V	3.1M	3.8M	0.9M	-56.9S	-6.2E
	120.0	-1.1P	1.8Q	3.1Q	3.7Q	0.9Q	-56.5W	6.2A
	240.0	-1.1V	-1.8U	2.9U	3.6U	0.9U	-55.8O	-6.1A
75.7	0.0	2.4M	0.1V	2.2M	3.2M	0.8M	-44.9S	-4.3E
	120.0	-1.2Q	2.0Q	2.2Q	3.2Q	0.8Q	-44.3W	4.4L
	240.0	-1.2U	-2.0U	2.1U	3.1U	0.8U	-42.9O	-4.5B
35.7	0.0	2.4M	0.1V	1.1M	2.6M	0.7M	-26.0S	-2.6E
	120.0	-1.2P	2.0Q	1.0Q	2.6Q	0.6Q	-25.0W	2.6A
	240.0	-1.2V	-2.0U	0.9U	2.5U	0.6U	-22.9O	-2.5A

* EFL/FR = EFFECTS OF FACTORED LOADS DIVIDED BY THE FACTORED RESISTANCE

MAXIMUM GUY FORCES AT ANCHOR

GUY LEVEL FT	GUY AZI	COMPONENTS AT ANCHOR			TOTAL	EFL/FR * RATIO
		RAD KIP	LAT KIP	VERT KIP	KIP	
185.7	0.0	2.0M	0.2P	2.9M	3.6M	0.5M
	120.0	2.0Q	0.2T	2.9Q	3.6Q	0.5Q
	240.0	2.1U	-0.2R	2.9U	3.5U	0.5U
155.7	0.0	2.4M	0.1P	3.0M	3.8M	0.6M
	120.0	2.4Q	0.1T	3.0Q	3.8Q	0.6Q
	240.0	2.4U	-0.1R	2.9U	3.7U	0.6U
115.7	0.0	2.2M	0.1P	2.1M	3.1M	0.8M
	120.0	2.2Q	-0.1N	2.1Q	3.0Q	0.8Q
	240.0	2.2U	0.1X	2.0U	3.0U	0.7U
75.7	0.0	2.4M	0.1P	1.5M	2.8M	0.7M



Reviewed for Code Compliance
 Inspections Division
 Approved with Conditions

Date: 10/07/13

90417.txt

120.0	2.4Q	-0.1N	1.4Q	2.8Q	0.7Q
240.0	2.4U	0.1X	1.3U	2.7U	0.7U
35.7	0.0	2.4M	0.1P	0.6M	2.4M
120.0	2.4Q	-0.1N	0.5Q	2.4Q	0.6Q
240.0	2.4U	0.1X	0.4U	2.4U	0.6U

MAXIMUM ANCHOR LOADS

AZI DEG	RADIUS FT	GUY TO ELEV FT	ANCHOR LOADS			SHAFT FORCES			ANGLE DEG
			HORIZ KIP	VERT KIP	LATERAL KIP	AXIAL KIP	VERT PLANE KIP	HORIZ PLANE KIP	
0.0	95.0	185.7	2.0M	2.9M	0.2P	3.5M	0.8M	0.2P	41.7M
		155.7	2.4M	3.0M	0.1P	3.8M	0.7M	0.1P	
		115.7	2.2M	2.1M	0.1P	3.1M	0.10	0.1P	
		75.7	2.4M	1.5M	0.1P	2.8M	-0.5M	0.1P	
		35.7	2.4M	0.6M	0.1P	2.2M	-1.1M	0.1P	
			11.4M	10.1M	0.6P	15.2M	0.0W	0.6P	
120.0	95.0	185.7	2.0Q	2.9Q	0.2T	3.4Q	0.8Q	0.2T	41.1Q
		155.7	2.4Q	3.0Q	0.1T	3.7Q	0.7Q	0.1T	
		115.7	2.2Q	2.1Q	-0.1N	3.0Q	0.1S	-0.1N	
		75.7	2.4Q	1.4Q	-0.1N	2.7Q	-0.5Q	-0.1N	
		35.7	2.4Q	0.5Q	-0.1N	2.1Q	-1.1Q	-0.1N	
			11.4Q	9.9Q	0.6T	15.1Q	0.0D	0.6T	
240.0	95.0	185.7	2.1U	2.9U	-0.2R	3.4U	0.9U	-0.2R	39.9U
		155.7	2.4U	2.9U	-0.1R	3.7U	0.7U	-0.1R	
		115.7	2.2U	2.0U	0.1X	3.0U	0.1S	0.1X	
		75.7	2.4U	1.3U	0.1X	2.7U	-0.5U	0.1X	
		35.7	2.4U	0.4U	0.1X	2.1U	-1.2U	0.1X	
			11.4U	9.5U	-0.5R	14.8U	0.0W	-0.5R	

MAXIMUM LOADS ON TOWER PIER

AXIAL kip	SHEAR			MOMENT			
	NORTH kip	EAST kip	TOTAL kip	NORTH ft-kip	EAST ft-kip	TOTAL ft-kip	TORSIONAL ft-kip
55.1773	0.1514	-0.1433	0.1592	0.0000	0.0000	0.0000	0.0774
O	A	J	I	M	E	E	N



Reviewed for Code Compliance
Inspections Division
Approved with Conditions

GUYED TOWER SPREAD FOOTING DESIGN BY SABRE TOWERS & POLES

188' 1800 NORTHERN PRIDE COMMUNICATIONS INC Portland, ME (90417) 9-27-13 TTW

Factored Axial Load (kips)	55.18
Factored Shear (kips)	0.14
Ultimate Bearing Pressure	2
Bearing Φ_s	0.6
Bearing Design Strength (ksf)	1.2
Diameter of Pier (ft)	2.5
Ht. of Pier Above Ground (ft)	0.5
Depth to Bottom of Slab (ft)	4.5
Ht. of Pier Below Ground (ft)	3

Maximum Factored Net Soil Bearing Pres
Equivalent Square b (ft) Date: 10/07/13
2.22

Width of Pad (ft)	8
Thickness of Pad (ft)	1.5
Quantity of Bars in Pad	9
Bar Diameter in Pad (in)	0.875
Area of Bars in Pad (in ²)	5.41
Spacing of Bars in Pad (in)	11.14
Quantity of Bars Pier	6
Bar Diameter in Pier (in)	0.875
Area of Bars in Pier (in ²)	3.61
Spacing of Bars in Pier (in)	11.72
f'c (ksi)	4
fy (ksi)	60
Unit Wt. of Soil (kcf)	0.11
Unit Wt. of Concrete (kcf)	0.15
Volume of Concrete (yd ³)	4.19

Recommended Spacing (in) 6 to 12

Minimum Pier Area of Steel (in²) 3.53
Recommended Spacing (in) 6 to 12

Two-Way Shear Action:

q_{ult} (ksf)	0.92
Average d (in)	14.13
ϕV_c (kips)	421.0
$\phi V_c = \phi(2 + 4/\beta_c)f'_c{}^{1/2}b_o d$	631.6
$\phi V_c = \phi(\alpha_s d/b_o + 2)f'_c{}^{1/2}b_o d$	639.6
$\phi V_c = \phi 4f'_c{}^{1/2}b_o d$	421.0
Shear perimeter, b_o (in)	138.62
β_c	1

V_u (kips) 49.0

One-Way Shear:

ϕV_c (kips)	145.8
-------------------	-------

V_u (kips) 12.6

Flexure:

ϕM_n (ft-kips)	331.9
a (in)	0.99
Steel Ratio	0.00399
β_1	0.85

M_u (ft-kips) 30.7

Maximum Steel Ratio	0.0214
Minimum Steel Ratio	0.0018

Rebar Development in Pad (in) 31.71

Required Development in Pad (in) 3.72

Condition	1 is OK, 0 Fails
Two-Way Shear Action	1
One-way Shear	1
Flexure	1
Steel Ratio	1
Pier Area of Steel	1
Maximum Soil Bearing Pressure	1
Length of Development in Pad	1



Reviewed for Code Compliance
Inspections Division
Approved with Conditions

GUY ANCHOR BLOCK DESIGN BY SABRE TOWERS & POLES

188' 1800 NORTHERN PRIDE COMMUNICATIONS INC Portland, ME (90417) 9-27-13 TTW

Anchor Block Dimensions:

Length (ft)	12
Height (ft)	2
Width (ft)	2
Longitudinal Bar Diameter (in)	0.625
Quantity of Bars in Top	4
Area of Bars in Top (in ²)	1.23
Spacing of Bars in Top (in)	5.38
Quantity of Bars Front	4
Area of Bars in Front (in ²)	1.23
Spacing of Bars in Front (in)	5.38
Quantity of Bars in Bottom	1
Spacing of Bars in Bottom (in)	17.06
Quantity of Bars in Back	1
Spacing of Bars in Back (in)	17.06
Quantity of Ties	13
Tie Bar Diameter (in)	0.625
Factored Uplift (kips)	10.13
Factored Horizontal Force (kips)	11.39
Ultimate Passive Pressure	0.646
Horizontal Φ_s	0.75
Horizontal Design Strength (ksf)	0.4845
Angle of Internal Friction (deg.)	30
Unit Wt. of Soil (kcf)	0.11
Water Table Below Grade (ft)	5
Depth to Bottom of Block (ft)	8
f'c (ksi)	4
fy (ksi)	60
Unit Wt. of Concrete (kcf)	0.15
Volume of Concrete (yd ³)	1.78

Length/Height Ratio	
Length/Width Ratio	
Height/Width Ratio	1.00
Width/Height Ratio	1.00
Vertical Flexure Ratio	0.14
Horizontal Flexure Ratio	0.16
Horizontal Force Ratio	0.98
Vertical Force Ratio	0.22

Date: 10/07/13

Recommended Spacing (in) **6 to 30**

Recommended Spacing (in) **6 to 30**

Horizontal Force:

Factored Horizontal Force (kips) **11.4** Horizontal Design Strength (kips) **11.6**

Uplift:

Wc, Weight of Concrete (kips)	4.2
W _R , Soil Resistance (kips)	56.4
Uplift Φ_s (kips)	0.75
(Φ_s)(W _R +W _C) (kips)	45.4
Factored Uplift (kips)	10.1
Uplift Design Strength (kips)	45.4

Vertical Shear:

V _u (kips)	5.1	ϕV_n (kips)	51.8
V _c = 2 f'c ^{1/2} b _w d (kips)	60.9		
V _s (kips)	0.0	*** V _s max = 4 f'c ^{1/2} b _w d (kips)	121.8

Spacing of Ties (in) 11.45
Max. Spacing (in) 10.03 (Only if Shear Ties are Required)

*** Ref. To Spacing Requirements ACI 11.5.4.3



Reviewed for Code Compliance
Inspections Division
Approved with Conditions

Date: 10/07/13

GUY ANCHOR BLOCK DESIGN BY SABRE TOWERS & POLES (CONTINUED)

188' 1800 NORTHERN PRIDE COMMUNICATIONS INC Portland, ME (90417) 9-27-13 TTW

Horizontal Shear

V_u (kips)	5.7	ϕV_n (kips)	
$V_c = 2 f'_c{}^{1/2} b_w d$ (kips)	60.9		
V_s (kips)	0.0	*** $V_s \text{ max} = 4 f'_c{}^{1/2} b_w d$ (kips)	
Spacing of Ties (in)	11.45		
Max. Spacing (in)	10.03	(Only if Shear Ties are Required)	
$(V_u/\phi V_n)_V + (V_u/\phi V_n)_H$	0.21		<1 OK

*** Ref. To Spacing Requirements ACI 11.5.4.3

Vertical Flexure:

M_u (ft-kips)	15.2	ϕM_n (ft-kips)	108.3
a (in)	0.90		
Steel Ratio	0.0025		
β_1	0.85		
Maximum Steel Ratio	0.0214		
Minimum Steel Ratio	0.0018		
Rebar Development (in)	69.00	Required Rebar Development (in)	1.63

Horizontal Flexure:

M_u (ft-kips)	17.1	ϕM_n (ft-kips)	108.3
a (in)	0.90		
Steel Ratio	0.0025		
Maximum Steel Ratio	0.021		
Minimum Steel Ratio	0.0018		
Rebar Development (in)	69.00	Required Rebar Development (in)	1.83
$(M_u/\phi M_n)_V + (M_u/\phi M_n)_H$	0.30	$(M_u/\phi M_n)_V + (M_u/\phi M_n)_H$	<1 OK

Condition	1 is OK, 0 Fails
Uplift Force	1
Horizontal Force	1
Flexure	1
Shear	1
Length of Development in Block	1
Steel Ratio	1

Calculated Strength > Factored Load O.K.