

DISPLAY THIS CARD ON PRINCIPAL FRONTAGE OF WORK



# CITY OF PORTLAND BUILDING PERMIT

This is to certify that DEVELOPMENT OF MARYLAND INC. Located At 636 WARREN AVENUE

Job ID: 2011-07-1778-HVAC CBL: 315 - B - 001 - 001 - - - -

has permission to Install Lennox HVAC unit on roof

provided that the person or persons, firm or corporation accepting this permit shall comply with all of the provisions of the Statues of Maine and of the Ordinances of the City of Portland regulating the construction, maintenance and use of the buildings and structures, and of the application on file in the department.

Notification of inspection and written permission procured before this building or part thereof is lathed or otherwise closed-in. 48 HOUR NOTICE IS REQUIRED.

A final inspection must be completed by owner before this building or part thereof is occupied. If a certificate of occupancy is required, it must be

Fire Prevention Officer

Code Enforcement Officer / Plan Reviewer

THIS CARD MUST BE POSTED ON THE STREET SIDE OF THE PROPERTY

PENALTY FOR REMOVING THIS CARD

SCANNED

O/C to close + scan  
NUP

## BUILDING PERMIT INSPECTION PROCEDURES

Please call 874-8703 or 874-8693 (ONLY)

or email: [buildinginspections@portlandmaine.gov](mailto:buildinginspections@portlandmaine.gov)

With the issuance of this permit, the owner, builder or their designee is required to provide adequate notice to the city of Portland Inspections Services for the following inspections. Appointments must be requested 48 to 72 hours in advance of the required inspection. The inspection date will need to be confirmed by this office.

- **Please read the conditions of approval that is attached to this permit!! Contact this office if you have any questions.**
- **Permits expire in 6 months. If the project is not started or ceases for 6 months.**
- **If the inspection requirements are not followed as stated below additional fees may be incurred due to the issuance of a "Stop Work Order" and subsequent release to continue.**

The project cannot move to the next phase prior to the required inspection and approval to continue, REGARDLESS OF THE NOTICE OF CIRCUMSTANCES.

IF THE PERMIT REQUIRES A CERTIFICATE OF OCCUPANCY, IT MUST BE PAID FOR AND ISSUED TO THE OWNER OR DESIGNEE BEFORE THE SPACE MAY BE OCCUPIED.



# PORTLAND MAINE

*Strengthening a Remarkable City, Building a Community for Life • [www.portlandmaine.gov](http://www.portlandmaine.gov)*

Director of Planning and Urban Development  
Penny St. Louis

Job ID: 2011-07-1778-HVAC      Located At: 636 WARREN      CBL: 315 - - B - 001 - - - -  
=

## Conditions of Approval:

### **Zoning**

1. This permit is being approved on the basis of plans submitted. Any deviations shall require a separate approval before starting that work.
2. The roof top HVAC unit shall comply with the maximum noise allowances for the B-4 zone. If complaints are received, the violations shall be mitigate by approval measures for deadening sound.

### **Fire**

Installation shall comply with City Code Chapter 10.

Fuel-fired boilers shall be protected in accordance with NFPA 101, *Life Safety Code*.

Installation shall comply with NFPA 211, *Standard for Chimneys, Fireplaces, Vents, and Solid Fuel-Burning Appliances*; NFPA 54, *National Fuel Gas Code*; NFPA 90A, *Standard for the Installation of Air-Conditioning and Ventilating Systems*; NFPA 70, *National Electrical Code*; and the manufacturer's published instructions.

RTU shall be clearly labeled.

### **Building**

1. This appliance/stove shall be installed, operated and maintained per the manufacturers specifications and the UL listing.

**City of Portland, Maine - Building or Use Permit Application**

389 Congress Street, 04101 Tel: (207) 874-8703, FAX: (207) 8716

Job No: 2011-07-1778-HVAC	Date Applied: 7/22/2011	CBL: 315 - - B - 001 - 001 - - - - -	
Location of Construction: 636 WARREN AVE	Owner Name: HD DEVELOPMENT OF MARYLAND INC	Owner Address: 2455 PACES FERRY RD ATLANTA, GA - GEORGIA 30339	Phone:
Business Name: Home Depot	Contractor Name: Design Air Systems	Contractor Address: 31803 Old Washington RD, Waller, TX 774-84	Phone: 936-931-3444
Lessee/Buyer's Name:	Phone:	Permit Type: HVAC	Zone: B-4
Past Use: Retail- Home Depot	Proposed Use: Same: Retail - to add Lennox HVAC system on the roof	Cost of Work: \$73000.00	CEO District:
		Fire Dept: <input checked="" type="checkbox"/> Approved w/ conditions <input type="checkbox"/> Denied <input type="checkbox"/> N/A	Inspection: Use Group: HVAC Type: 7
Proposed Project Description:		Signature: <i>Bjorn [unclear]</i> (58)	Signature: <i>[unclear]</i>
		Pedestrian Activities District (P.A.D.)	

Permit Taken By: Lannie	<b>Zoning Approval</b>		
<p>1. This permit application does not preclude the Applicant(s) from meeting applicable State and Federal Rules.</p> <p>2. Building Permits do not include plumbing, septic or electrical work.</p> <p>3. Building permits are void if work is not started within six (6) months of the date of issuance. False informatin may invalidate a building permit and stop all work.</p>	<b>Special Zone or Reviews</b> <input type="checkbox"/> Shoreland <input type="checkbox"/> Wetlands <input type="checkbox"/> Flood Zone <input type="checkbox"/> Subdivision <input type="checkbox"/> Site Plan <input type="checkbox"/> Maj <input type="checkbox"/> Min <input type="checkbox"/> MM Date: <i>OK with conditions</i> <i>[Signature]</i> 7/28/11	<b>Zoning Appeal</b> <input type="checkbox"/> Variance <input type="checkbox"/> Miscellaneous <input type="checkbox"/> Conditional Use <input type="checkbox"/> Interpretation <input type="checkbox"/> Approved <input type="checkbox"/> Denied Date:	<b>Historic Preservation</b> <input checked="" type="checkbox"/> Not in Dist or Landmark <input type="checkbox"/> Does not Require Review <input type="checkbox"/> Requires Review <input type="checkbox"/> Approved <input type="checkbox"/> Approved w/Conditions <input type="checkbox"/> Denied Date: <i>[Signature]</i>
	<b>CERTIFICATION</b>		

I hereby certify that I am the owner of record of the named property, or that the proposed work is authorized by the owner of record and that I have been authorized by the owner to make this application as his authorized agent and I agree to conform to all applicable laws of this jurisdiction. In addition, if a permit for work described in the application is issued, I certify that the code official's authorized representative shall have the authority to enter all areas covered by such permit at any reasonable hour to enforce the provision of the code(s) applicable to such permit.

SIGNATURE OF APPLICANT	ADDRESS	DATE	PHONE
RESPONSIBLE PERSON IN CHARGE OF WORK, TITLE		DATE	PHON



FILL IN AND SIGN WITH INK

# APPLICATION FOR PERMIT HEATING OR POWER EQUIPMENT

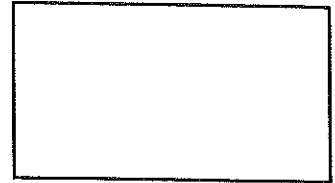

B-4

To the INSPECTOR OF BUILDINGS, PORTLAND, ME.

The undersigned hereby applies for a permit to install the following heating, cooking or power equipment in accordance with the Laws of Maine, the Building Code of the City of Portland, and the following specifications:

Location / CBL 315 B001 Use of Building 636 Wallen / 232 Riverside Date 7-19-11

Name and address of owner of appliance HOME DEPOT 245 RIVERSIDE ST  
PORTLAND, ME 04103

Installer's name and address DESIGN AIR SYSTEMS 31803 OLD WASHINGTON RD  
WALLER, TX 77484 Telephone 936 981 3444

### Location of appliance:

- Basement
- Floor
- Attic
- Roof

### Type of Fuel:

- Gas
- Oil
- Solid

Appliance Name: LENNOX

U.L. Approved  Yes  No

Will appliance be installed in accordance with the manufacture's installation instructions?  Yes  No

IF NO Explain: \_\_\_\_\_

### The Type of License of Installer:

- Master Plumber # \_\_\_\_\_
- Solid Fuel # \_\_\_\_\_
- Oil # \_\_\_\_\_
- Gas # \_\_\_\_\_
- Other TACLA12208C

### Type of Chimney:

- Masonry Lined  
Factory built N/A
- Metal  
Factory Built U.L. Listing # N/A
- Direct Vent  
Type \_\_\_\_\_ UL# \_\_\_\_\_

### Type of Fuel Tank

- Oil
- Gas

RECEIVED

JUL 22 2011

Size of Tank Dept. of Building Inspections  
City of Portland Maine

Number of Tanks \_\_\_\_\_

Distance from Tank to Center of Flame \_\_\_\_\_ feet.

Cost of Work: \$ 72,300

Permit Fee: \$ 750.00

N/E/C

### Approved

### Approved with Conditions

Fire: \_\_\_\_\_  
Ele.: \_\_\_\_\_  
Bldg.: \_\_\_\_\_

See attached letter or requirement

Inspector's Signature \_\_\_\_\_ Date Approved \_\_\_\_\_

Signature of Installer [Signature]

# Lennox Industries Inc. - Product Submittal

System ID: RTU 1,5,9

Package Model: LGH240H4B

Description: PKGGE/20TON/CONFIGURABLE

## DIMENSIONS - INCHES (MM)

Model No.	AA		BB		CC		DD		CENTER OF GRAVITY			
	lbs.	kg	lbs.	kg	lbs.	kg	lbs.	kg	in.	mm	in.	mm
LGH210 Std. Unit	497	234	513	242	671	317	648	306	54-3/4	1391	39-1/2	1003
LGH210 Max. Unit	607	286	598	282	700	330	710	335	53-1/2	1359	42	1067
LGH240 Std. Unit	507	239	533	252	713	336	677	320	55-1/4	1403	39	991
LGH240 Max. Unit	617	291	620	292	741	350	738	348	54	1372	41-1/2	1054
LGH300 Std. Unit	513	242	535	252	739	349	709	334	55	1397	38-1/4	972
LGH300 Max. Unit	623	294	620	293	767	362	770	363	53-3/4	1365	40-3/4	1035

Std. Unit - The unit with NO OPTIONS.  
 Max. Unit - The unit with ALL OPTIONS installed. (Economizer, etc.)

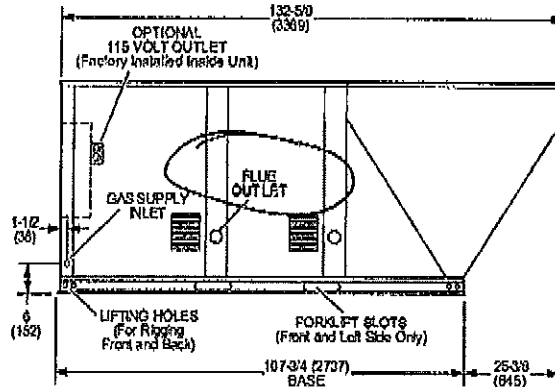
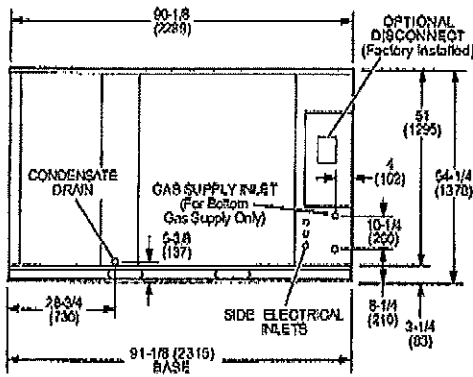
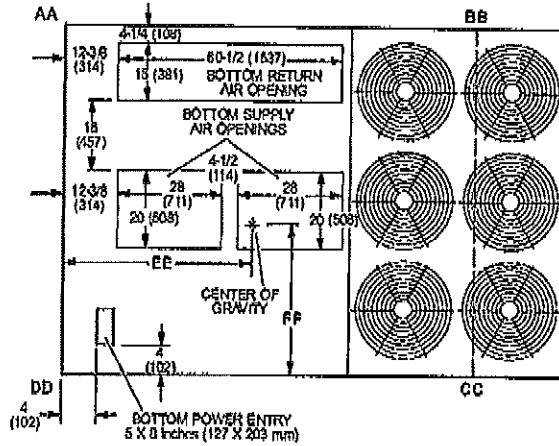

**Lennox Industries Inc. - Product Submittal**

System ID: RTU 1,5,9	Description: PKGGE/20TON/CONFIGURABLE
Package Model: LGH240H4B	

**HEATING PERFORMANCE**

Heat Source	Natural Gas	Gas Supply Connection	1.00 (in.)
H/E LowInput	312000 (Btuh)	H/E Heat Rise	44.4 (°F)
H/E HighInput	480000 (Btuh)	APUE/ ThermalEff	80
H/E HighOutput	384000 (Btuh)	Number of Heating Stages	2
System HeatOutput	384000 (Btuh)	Gas Supply Pressure	11 (in.WC)

**COOLING PERFORMANCE**

Refrigerant	R-410A	Number Compressors	4
ARI EER	12.0	Number of Cooling Stages	2
ARI IEER	12.6	Condensate Drain Size	1.00 (in.)
ARI Total Power	19200 (W)	Cooling OutdoorDB	95.0 (°F)
ARI GrossTotalCool	238000 (Btuh)	Cooling MixedDB	80.0 (°F)
ARI NetTotalCool	230000 (Btuh)	Cooling MixedWB	67.0 (°F)
Coil GrossTotalCool	247300 (Btuh)	Coil DischargeDB	57.1 (°F)
Coil NetTotalCool	230813 (Btuh)	Coil DischargeWB	56.8 (°F)
Coil GrossSensCool	192894 (Btuh)	Unit DischargeDB	59.0 (°F)
Coil NetSensCool	176407 (Btuh)	Unit DischargeWB	57.6 (°F)
		Coil MoistureRemoval	51.3 (lb/hr)
		System MoistRemoval	51.3 (lb/hr)

**SUPPLY FAN PERFORMANCE**

Supply Fan Total Air Flow	8000 (cfm)	TotalStaticPress	1.28 (in.WC)
Supply AirFlow	8000 (cfm)	Wet Coil Static Press	0.13 (in.WC)
ExtStaticPress Supply	0.80 (in.WC)	Gas H/E Static Press	0.24 (in.WC)
SupplyFan Req'dPower	5.74 (hp)	Economizer Static Press	0.11 (in.WC)
SupplyFan NomPower	7.50 (hp)	Air Filter Qty	6
Supply Fan Type	CAV Belt Drive	Air Filter Length	24.0 (in.)
SupplyDriveReq'd RPM	1007 (rpm)	Air Filter Width	24.0 (in.)
SupplyDrive Min RPM	850 (rpm)	Air Filter Thickness	2.0 (in.)
SupplyDrive Max RPM	1045 (rpm)		

**ELECTRICAL**

Voltage	460V 3Ph	SupplyFan FLA	11.1 (amp)
Frequency	60 (Hz)	CondensingUnit FLA	7.8 (amp)
System MCA	54.0 (amp)	CondenserFan Power	1950 (W)
System MOCp	60 (amp)	Unit Oper Range	+/- 10%
Compressors RLA	24.0 (amp)		
System FLA	42.9 (amp)		

**DIMENSIONS**

Cabinet Width	91.1 (in.)	Downflow Supply Length	20.0 (in.)
Cabinet Length	132.6 (in.)	Downflow Supply Width	28.0 (in.)
Cabinet Height	54.3 (in.)	Downflow Return Length	15.0 (in.)
Total Weight	2580 (lb)	Downflow Return Width	60.5 (in.)

**SOUND**

Outdoor Sound Rating	94 (db)
----------------------	---------

# INSTALLATION INSTRUCTIONS

## LF24

100,000 to 400,000 Btuh Series

UNIT HEATERS  
 503,523M  
 01/2008  
 Supersedes 10/2006  
 See unit nameplate for manufacturer and address.  
 ©2008

**TP** Technical Publications  
 Litho U.S.A.

### Table Of Contents

LF24 Unit Dimensions .....	1	Unit Start-Up .....	10
Shipping .....	2	To Turn Off Gas to Unit .....	13
Optional Accessories .....	2	Heating Sequence of Operation .....	13
CSA Requirements in USA .....	3	Ignition Control LED .....	13
CSA Requirements in Canada .....	3	High Altitude Adjustment .....	13
Additional Requirements .....	3	Gas Flow .....	15
Unit Heater Installation .....	3	Gas Pressure Adjustment .....	15
Combustion and Ventilation Air .....	4	Limit Control Switch .....	15
Rotation of Combustion Air Inducer .....	4	Louver Vane Adjustments .....	15
Venting .....	5	Combustion Air Pressure Switch .....	15
Electrical Connections .....	9	Service .....	15
Typical LF24 Wiring Diagram .....	9	Start-Up and Performance Checklist .....	16
Gas Connection .....	10	Template .....	17
Leak Check .....	10		

**RETAIN THESE INSTRUCTIONS FOR FUTURE REFERENCE**



### ▲ WARNING

**if the information in this manual is not followed exactly, a fire or explosion may result causing property damage, personal injury or loss of life.**



**Do not store or use gasoline or other flammable vapors and liquids in the vicinity of this or any other appliance.**

**Installation and service must be performed by a qualified installer, service agency or the gas supplier.**

### WHAT TO DO IF YOU SMELL GAS:

- Do not try to light any appliance.
- Extinguish any open flame.
- Do not touch any electrical switch; do not use any phone in your building.
- Immediately call your gas supplier from a neighbor's phone. Follow the gas supplier's instructions.
- If you cannot reach your gas supplier, call the fire department.



**LF24 Unit Dimensions**

NOTE — LF24 models 100, 115, 145, 175 and 200 have a single fan. LF24 models 230, 250, 300, 345 and 400 have two fans.

NOTE — Two spot nuts are furnished on LF24 models 100, 115, 145, 175 and 200. Four spot nuts are furnished on LF24 models 230, 250, 300, 345 and 400 models.

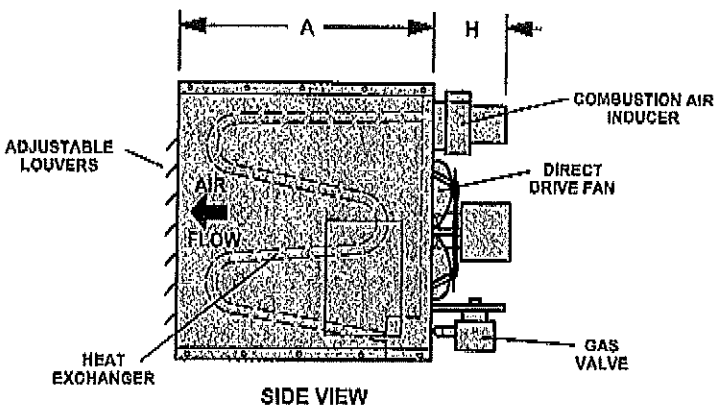
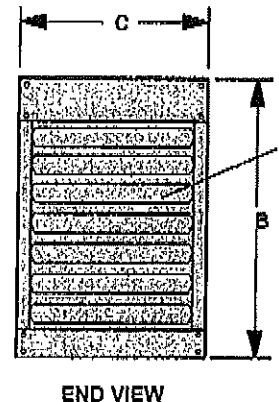
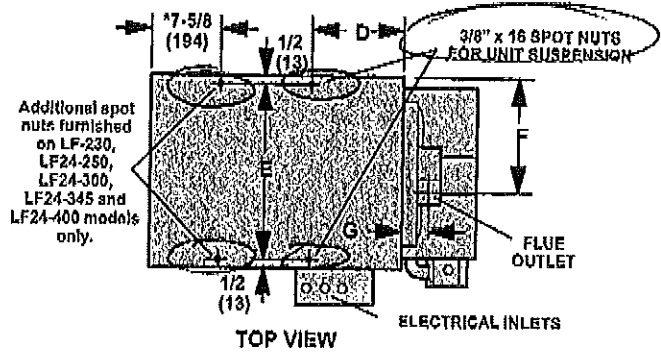

Unit	A		B		C		D		E		F		G		H	
	In.	mm	In.	mm	In.	mm	In.	mm	In.	mm	In.	mm	In.	mm	In.	mm
LF24-100 LF24-115 LF24-145	31-5/16	795	32-3/16	817	20-3/16	512	11-1/2	292	19-1/16	484	11-3/4	298	3-1/4	83	7-7/8	200
LF24-175 LF24-200	31-5/16	795	32-3/16	817	23-1/8	588	11-1/2	292	22-1/16	560	8-1/2	216	3-1/4	83	8-11/16	220
LF24-230* LF24-250* LF24-300*	31-5/16	795	32-3/16	817	41-1/8	1045	3-11/16	97	40	1016	17-3/4	451	3-1/2	89	8-11/16	220
LF24-345* LF24-400*	31-5/16	795	32-3/16	817	41-1/8	1045	3-11/16	97	40	1016	17-1/2	445	3-1/2	89	9-13/16	248

\*Unit contains dual fans.

**Shipping**

The heater is completely assembled and is shipped with installation and operating instructions, warranty certificate and flue transition. Upon receipt, check the unit for shipping damage. The receiving party should contact the last carrier immediately if any damage as a result of shipping is found.

**Optional Accessories**

TABLE 1

LF24-100 to LF24-230							
Gas Heating Performance	Model No. - Stainless Steel	LF24-100S	LF24-115S	LF24-145S	LF24-175S	LF24-200S	LF24-230S
	Model No. - Aluminized Steel	LF24-100A	LF24-115A	LF24-145A	LF24-175A	LF24-200A	LF24-230A
<b>Optional Accessories - Must Be Ordered Extra</b>							
Discharge Nozzle	30° - 94K96	*	*	*	*	*	*
	45° - 95K00	*	*	*	*	*	*
	60° - 16L30	*	*	*	*	*	*
	90° - 15L98	*	*	*	*	*	*
Hanging Bracket Kit	87277	*	*	*	*	*	*
High Altitude Pressure Switch Kit*	43K58	*					
	10K73		*	*	*	...	...
LPG/Propane Kit	45L85	*					
	63J56		*	*	*		
	20L07					*	
	63J57						*

\* Required for proper unit operation at altitudes over 5501 feet above sea level.

TABLE 2

LF24-250 to LF24-400					
Gas Heating Performance	Model No. - Stainless Steel	LF24-250S	LF24-300S	LF24-345S	LF24-400S
	Model No. - Aluminized Steel	LF24-250A	LF24-300A	LF24-345A	LF24-400A
<b>Optional Accessories - Must Be Ordered Extra</b>					
Discharge Nozzle	30° - 94K96	*	*	*	*
	45° - 95K00	*	*	*	*
	60° - 16L30	*	*	*	*
	90° - 15L98	*	*	*	*
Hanging Bracket Kit	87277	*	*	*	*
LPG/Propane Kit	45L88	*	*		
	63J57			*	
	20L06				*

**CSA Requirements in USA**

Installation of gas unit heaters must conform with local building codes or, in the absence of local codes, with the current edition of ANSI-Z223.1, National Fuel Gas Code.

Installation in aircraft hangers must be in accordance with the current edition of ANSI/NFPA No. 409, Standard for Aircraft Hangers.

Installation in parking structures must be in accordance with the current edition of ANSI/NFPA No. 88A, Standard for Parking Structures.

Installation in repair garages must be in accordance with the current edition of ANSI/NFPA No. 88B, Standard for Repair Garages.

Authorities having jurisdiction should be consulted before installation. Air for combustion and ventilation must conform to the methods outlined in ANSI Z223.1, section 5.3, Air for Combustion and Ventilation, or applicable provisions of local building codes.

ANSI-Z223.1, National Fuel Gas Code is available from:

*American National Standard Institute Inc.  
11 West 42nd Street  
New York, NY 10036*

These units are C.S.A. international design certified. These unit heaters are certified for clearances to combustible material as listed in table 1 and on unit rating plate.

Accessibility and service clearances must be observed in addition to fire protection clearances.

All electrical wiring and grounding for unit must be in accordance with the regulations of the current edition of ANSI/NFPA No. 70, National Electric Code.

The National Electric Code is available from:

*National Fire Protection Association  
1 Batterymarch Park  
PO Box 9101  
Quincy, MA 02269-9101*

**CSA Requirements in Canada**

The instructions are intended only as a general guide and do not supersede local codes in any way. Authorities having jurisdiction should be consulted before installation. The installation must conform with local building codes or in the absence of local codes the current edition of CSA-B149 Installation compliance codes. All electrical wiring and grounding for the unit must also comply with the current edition of CSA C22.1, Canadian Electrical Code.

These unit heaters are CSA-certified for clearances to combustible material listed on the rating plate and table 1. Adequate clearance must be provided around the appliance and around air openings into the combustion chamber. Provision must be made for service accessibility.

**NOTE:** Fire protection clearances may be exceeded to provide additional space for service and accessibility.

**PUBLIC GARAGE**

- 1 - In a storage area, clearance from the heater to combustible materials must be such that the combustible material must not attain a temperature above 160°F (71°C) during continuous operation of the unit.
- 2 - Maintain an 8-foot (2.5 m) minimum clearance from the floor to the bottom of the heater. Refer to the current edition of CSA-B149 installation compliance codes.

**AIRCRAFT HANGER**

- 1 - In an area where aircraft are housed or serviced, a 10-foot (3 m) minimum clearance from the highest surface of the aircraft to bottom of the heater must be maintained.
- 2 - In other areas an 8-foot (2.5 m) minimum clearance from the floor to bottom of heater must be maintained.
- 3 - Heaters should be located so that they are protected from damage from aircraft or other appliances needed for servicing of aircraft. Refer to requirements of the enforcing authorities.

In a confined area, the heater must be installed in accordance with the CSA-B149 installation compliance codes. Be sure to check with local codes and ordinances for additional requirements.

**Additional Requirements**

The Commonwealth of Massachusetts stipulates the following additional requirements:

- 1 - Gas furnaces shall be installed by a licensed plumber or gas fitter only.
- 2 - The gas cock must be "T handle" type.

**Unit Heater Installation**

Install the unit in the desired location as governed by clearances, vent connection, air direction, gas supply, electrical supply and service accessibility.

On LF24 models 100, 115, 145, 175, and 200, spot nuts are furnished at the balance point (two positions only). On LF24 models 230, 250, 300, 345 and 400, spot nuts are furnished at each corner of the unit. Spot nuts will accommodate 3/8" x 16 threaded rods.





- 1 - Cut threaded rods to desired length and slide a 3/8" nut onto the rod.
- 2 - Slide a flat washer onto the threaded rod AFTER the nut (7/16" inside diameter X 1" outside diameter X 1/16" thick washer).
- 3 - Screw the rods (two or four) into the spot nuts on the unit.
- 4 - Tighten nuts to secure unit to rods.

**▲ IMPORTANT**

Do not use the gas manifold pipe to lift unit. Any excessive upward or downward force on the manifold pipe and bracket assembly can cause the ignition burner and igniter to become misaligned.

**TABLE 3  
UNIT CLEARANCES TO COMBUSTIBLE MATERIALS**

Top		Sides		Bottom		Rear		Fluo	
in	mm	in	mm	in	mm	in	mm	in	mm
6	152	6	152	0	0	18	457	6	152

**TABLE 4  
MAXIMUM MOUNTING HEIGHTS**

Model Number	Feet (Meters)
LF24-100 and LF24-115	16 (4.9)
LF24-145, LF24-175, and LF24-200	20 (6.1)
LF24-230, LF24-250, LF24-300, LF24-345 and LF24-400	30 (9.1)

**Combustion and Ventilation Air**

Adequate facilities for supplying air for combustion and ventilation must be provided in accordance with the current edition of ANSI Z223.1, section 5.3, and CSA-B149 installation compliance codes, or applicable provisions of local building codes.

All gas-fired appliances require air to be used for the combustion process. In many buildings today, there is a negative indoor air pressure caused by exhaust fans, etc. If sufficient quantities of combustion air are not available, the heater or another appliance will operate in an inefficient manner, resulting in incomplete combustion which can result in the production of excessive carbon monoxide.

**▲ CAUTION**

Insufficient combustion air can cause headaches, nausea, dizziness, asphyxiation or death.

If indoor air is to be used for combustion, it must be free of the following substances or the life of the heat exchanger will be adversely affected: chlorine, carbon tetrachloride, cleaning solvent, halogen refrigerants, acids, cements and glues, printing inks, fluorides, paint removers, varnishes, or any other corrosives.

**Rotation of Combustion Air Inducer**

The combustion air inducer on some units may be rotated to better suit individual applications. The combustion air inducer on LF24 models 100, 115 and 145 may be rotated 90° either to the left or right of the original vertical position.

*NOTE - It is not permissible to rotate the combustion air inducer on LF24 models 175, 200, 230, 250, 300, 345 and 400.*

Rotate the induced draft assembly as follows:

- 1 - Remove the unit heater from the carton.
- 2 - Decide unit heater orientation. It may be advantageous to rotate the combustion air inducer. The vent can be installed in one of three discharge positions: up, left, or right. If the inducer is to be rotated, follow the instructions in this section; otherwise, refer to instructions under "Venting" section.
- 3 - Before making an electrical or gas connections, remove the securing screws on the flue box/combustion air inducer. See figure 1.

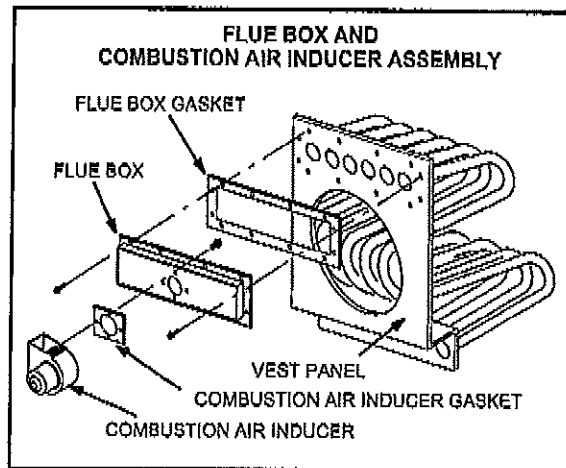

**FIGURE 1**

- 4 - Remove the flue box/combustion air inducer assembly ensuring that the gasket is not damaged. Should the gasket become damaged, replace it.

- 5 - Use a 1/4" socket to remove the three screws which secure the combustion air inducer. Remove the inducer and gasket from the flue box ensuring that the gasket is not damaged. Should the gasket become damaged, replace it.
- 6 - Use the template provided in the back of this manual to mark new hole locations. Drill holes in flue box with a 7/32" in drill bit.
- 7 - Rotate both the inducer and the gasket 90° to the desired position. Reinsert and tighten the three inducer securing screws (#8-16 X 1/2" HWHSMS). Place the gasket between the combustion air inducer and the flue box.
- 8 - Position the flue box/combustion air inducer assembly on the vent panel. Place the gasket between the flue box and the vent panel. Fasten the flue box using the flue box securing screws (#10-16 X 5/8" HWHSMS) and a 5/16" driver.
- 9 - The unit heater is now ready for installation as described in the section under Venting.



**Venting**

*NOTE - The vent is a passageway, vertical or nearly so, used to convey flue gases from an appliance, or its vent connector, to the outside atmosphere. The vent connector is the pipe or duct that connects a fuel-gas burning appliance to a vent or chimney.*

*NOTE - Local codes may supersede any of these provisions.*

**GENERAL RECOMMENDATION AND REQUIREMENTS**

LF24 unit heaters must be vented in compliance with all local codes or requirements of the local utility, the current standards of the ANSI Z223.1 or CSA-B149 installation compliance codes, and the following instructions.

A sheet metal flue transition is supplied with this certified unit. It must not be modified or altered and must be installed on the outlet of the combustion air inducer assembly prior to the installation of the vent connector. Failure to comply with this requirement will void the certification of the unit by the approval agencies.

In all cases, a flue transition piece (supplied) is required to fit over the outlet of the combustion air inducer assembly on the appliance.

A single-wall vent must have all seams and joints sealed with pressure-sensitive aluminum tape or silicone rubber sealant. Aluminum tape must meet the provisions of SMACNA AFTS-100-73 Standards. The aluminum tape must have a temperature rating of 400°F (204°C). Silicone rubber sealant must have a temperature rating of 482°F (250°C), i.e., Dow Corning RTV-736 or equivalent. All joints must be secured with at least two corrosion resistant screws. All joints must be checked for gas tightness after installation. Single-wall vent must not pass through any attic, interior wall, concealed space, or floor.

**TABLE 5  
VENT CONNECTOR DIAMETERS**

Model Number	Connector Diameter
LF24-100, LF24-116 LF24-145	4" (102mm)
LF24-175 LF24-200 LF24-230 LF24-260 LF24-300*	5" (127mm)
LF24-345 LF24-350 LF24-400*	6" (152mm)

\* On LF24-400 models, a minimum 6" (152mm) straight section must be placed between the flue transition and the first elbow of the vent.

**VERTICAL VENTS USING METAL VENT PIPE**

All LF24 unit heaters are listed as Category 1 appliances for vertical vent installations.

- 1 - All LF24 unit heaters are to be used with NFPA- or ANSI- approved chimneys or U.L.-listed type B-1 gas vents where applicable, as well as the modifications and limitations listed in figure 2.
- 2 - Keep the vent connector runs as short as possible with a minimum number of elbows. Refer to ANSI Z223.1 or CSA-B149 installation compliance codes for maximum vent and vent connector lengths. Horizontal run of the vent connector from the combustion air inducer outlet to the chimney/vent pipe cannot exceed the values in table 6. A single 3" (76 mm), 4" (102mm), or 5" (127 mm) elbow is equivalent to 5 feet (1.53 m) of vent pipe. A single 6" (152mm) elbow is equivalent to 9 feet (2.75 m) of vent pipe.
- 3 - When the length of a single wall-vent connector, including elbows, exceeds the length shown in table 3, the vent connector must be insulated along its entire length with a minimum of 1/2" (15mm) thick

foil faced fiberglass 1-1/2 pound density insulation. If a single-wall vent connector is used in an unheated area it must be insulated. Failure to do so will result in condensation of flue gases.

- 4 - All LF24 models may be vented vertically as a single appliance, or as a common vent with other gas-fired appliances. In a common venting situation, vent connectors for other appliances must be joined to the vent at least 4" (102 mm) above the connected LF24 connection. When common venting with another LF24 unit, maintain at least a 4" (102 mm) vertical separation between the vent connectors.
- 5 - Clearance to combustible material is 6" (152mm) for single-wall vent pipe except where a listed clearance thimble is used. Clearance to combustible material for type B-1 vent or factory-built chimney is per manufacturer's instructions.
- 6 - The vent connector must be supported with hangers no more than three feet (1 m) apart to prevent movement after installation. All horizontal vent connector runs must have a slope up to the vertical vent of at least 1/4" per foot (1mm per 50mm).
- 7 - All vertical vents must be terminated with a listed vent cap or rain shield assembly unless local codes permit otherwise.
- 8 - The vent pipe must extend at least 3 feet (1m) above the highest point where it passes through a roof of a building and at least two feet higher than any part of a building within a horizontal distance of 10 feet (3.05 m) unless otherwise specified by the ANSI Z223.1 or CSA-B149 installation compliance codes. The vent must extend at least 5 feet (1.53 m) above the highest connected equipment flue collar.

**HORIZONTAL VENTING**

*NOTE - Common venting is not allowed when horizontally venting the unit heater.*

If the LF24 unit heater is to be horizontally vented, a positive pressure may be created in the vent. The LF24 unit heater, when installed with horizontal venting, may perform as a category III appliance. Use single-wall vent material installed according to this section or use listed special vent for Category III appliances. Refer to figures 3, 4, and 5. The minimum horizontal vent length is 5 feet (1.53 m). Refer to table 6 for the maximum horizontal vent length and the number of elbows permitted.

**TABLE 6  
MAXIMUM HORIZONTAL VENT LENGTHS**

No. of Elbows	LF24-100, -115, -145, -175, and -200		LF24-230, -250 and -300		LF24-345		LF24-400	
	ft	m	ft	m	ft	m	ft	m
1	25	7.6	35	10.7	31	9.4	21	6.4
2	20	6.1	30	9.1	22	6.7	12	3.6
3	15	4.6	25	7.6	13	4.0	3	0.9
4	10	3.0	20	6.1	4	1.2	--	--
5	5	1.5	15	4.6	--	--	--	--
6	--	--	10	3.0	--	--	--	--
7	--	--	5	1.5	--	--	--	--

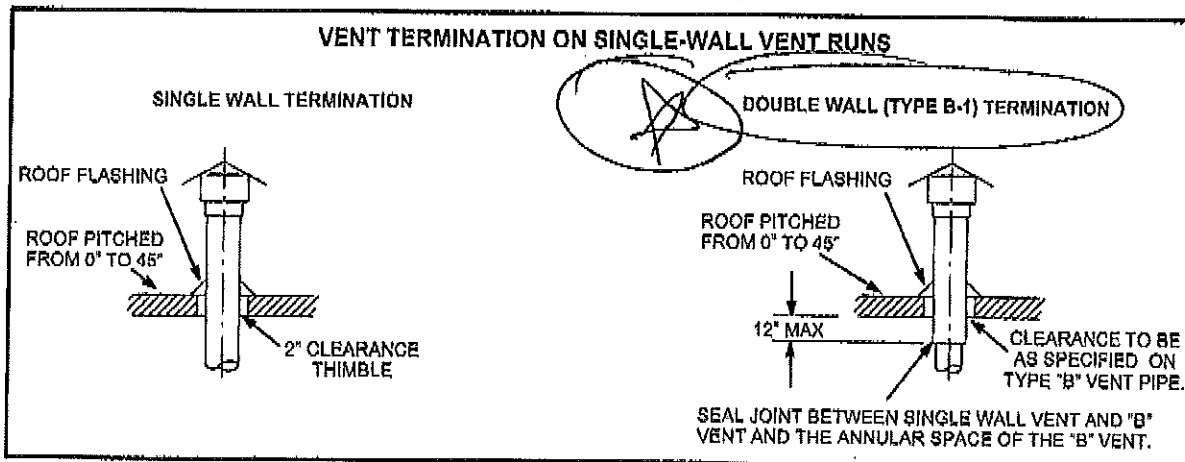

**FIGURE 2**

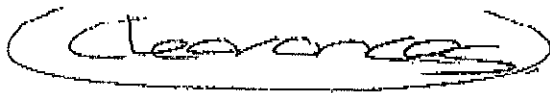

- 1 - Select a wall termination point that will maintain 1/4" rise per foot slope of horizontal run of vent pipe. In areas where authorities having jurisdiction permit, a downward slope of maximum 1/4" per foot is also acceptable. In such cases, a single-wall vent pipe must be constructed of no. 24 GSG galvanized steel. Condensate drainage can be collected in a tee pipe section (figure 4) with drain loop similar to one used for upward slope vent, or allowed to drip through the vent termination, if permitted by authorities (figure 5).
- 2 - If possible, do not terminate the horizontal vent through a wall that is exposed to prevailing wind. Exposure to excessive winds can affect unit performance. If such a termination is necessary, use a wind block to protect the vent termination from direct winds.
- 3 - Vent termination must be at least 12" (30.5 cm) above grade level and maximum snow height.
- 4 - Do not terminate vent above a walkway, or any other area where condensate dripping may be troublesome and may cause some staining. Avoid windows where steam may cause fogging or ice buildup.
- 5 - Horizontal vent termination must be a minimum distance from any door, window, gravity air inlet, or gas or electric meter. Refer to NFPA 54/ANSI Z223.1 or CSA-B149.
- 6 - Vent termination must be a minimum of 4 feet (1.2m) horizontally from any soffit or under-eave vent.
- 7 - Vent must be a minimum of 6 feet (1.83 m) from an inside corner formed by two exterior walls. If possible, leave a 10-foot clearance.
- 8 - Vent termination must be a minimum of 10 feet (3m) from any forced air inlet (includes fresh air inlet for other appliances, such as a dryer).
- 9 - For upward sloped vent, see figure 3, condensate tee and drain must be installed within the first 5 feet (1.53 m) from the unit heater to protect the appliance.
- 10 - Flexible loop trap in condensate line (if used) must be filled with water to prevent combustion products from entering structure.

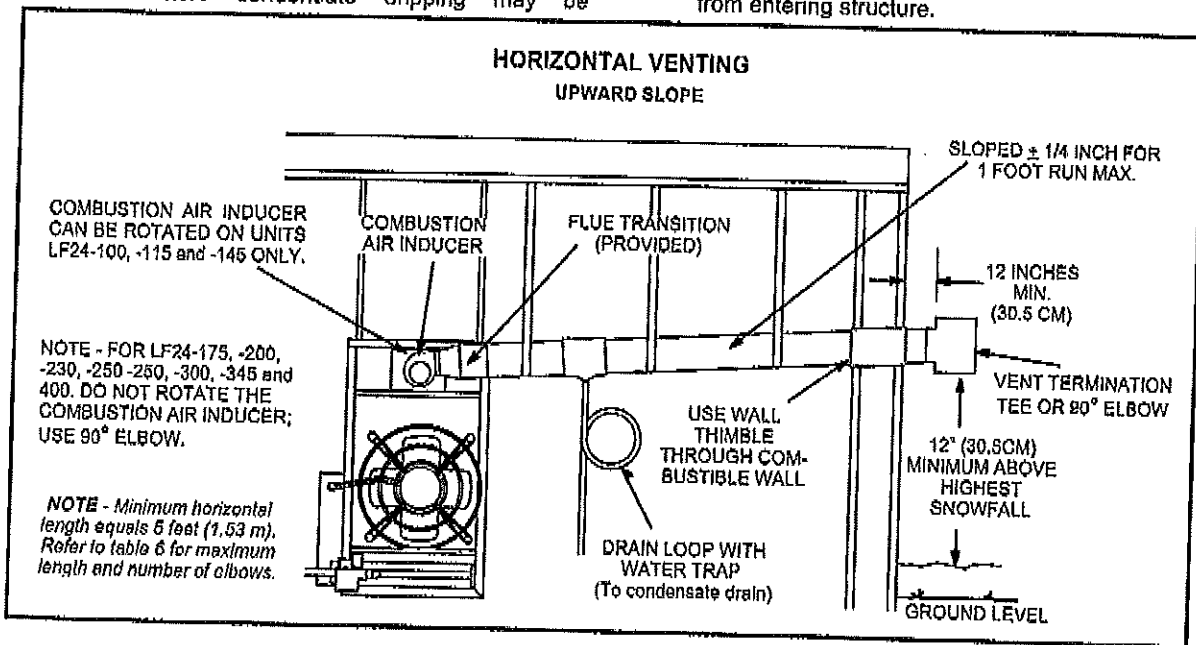

# BARRY LEVIN & ASSOCIATES, Inc.

STRUCTURAL ENGINEERS

Atlanta • Los Angeles • New York • Chicago



July 21, 2011

Attn: Mr. Gregory Beesch  
Quality Project Management, LLC (QPM)

Re: Analysis of Existing Roof Framing for New Roof Top Units  
Home Depot – Portland, ME [Store No. 2401]  
BLA Project No. 2011-254

Dear Greg:

As per our earlier discussions, The Home Depot intends to replace all roof top units at the above referenced store. Barry Levin and Associates (BLA) had performed the original structural design of this building in 1996 and had developed the original structural construction documents. Barry Levin and Associates has been requested to review the existing drawings to determine the ability of the existing roof framing to support the new units. Barry Levin and Associates has located the project drawings from the archives and reviewed these drawings for the pertinent information related to the project. It is Barry Levin and Associates understanding that existing roof top units placed are to be replaced by new roof top units with curb adapters at the same locations.

Based on site visit performed on July 20, 2011, conducted by the contractor (Chris Newcomer of Design Air systems) and the letter dated July 20, 2011, it appears that the existing unit locations correspond to those shown on the original roof framing plan prepared by Barry Levin and Associates.

The review of the capacity of the existing roof framing to support the new RTUs is based on the following information:

1. Drawing S3.0, Existing Roof Framing Plan by Barry Levin and Associates
2. New unit weights and new curb adaptor weights as provide by Derek Garen of Lennox.
3. Weight comparison table for new versus the existing RTU's.

Based on the review of the existing roof framing and weights of the new roof top units (RTUs) plus the weight of the curb adapters and the weight of the existing roof curb, BLA has determined the existing roof framing is capable of supporting the new equipment.

BLA appreciates this opportunity to be of service to QPM. If you have any questions, comments, or concerns regarding the above referenced items, do not hesitate to contact our office at your earliest convenience.

Sincerely,

Shakeel Mohammed  
Project Engineer

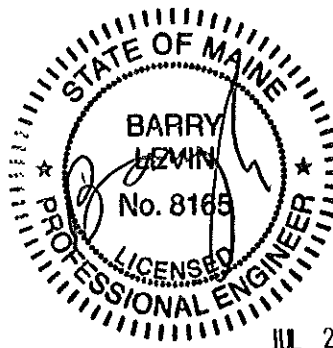

Barry Levin, P.E.  
President

JUL 21 2011

Enc: Drawing R1.0, Existing drawing S3.0, cut sheets for curb adapters, Site visit letter from Chris Newcomer, and new RTU weights.

Cc: Bill Bornhorst                      BLA/GA  
Bernard Oles                              BLA/NJ





**DESIGN AIR SYSTEMS**

TACLA002176E

31803 OLD WASHINGTON ROAD  
WALLER, TEXAS 77484  
(936) 931-3444  
FAX (936) 931-9118

July 20, 2011

Barry Levin and Associates  
370 Campus Drive, Suite 101  
Somerset, New Jersey 08873

RE: Rooftop A/C Unit Assessment

Mr. Shakeel Mohammed,

The rooftop a/c units were assessed today and the locations are correct and match the S3 drawing dated 3-29-96. Thank you.

Sincerely,  
DESIGN AIR SYSTEMS

A handwritten signature in black ink, appearing to read 'Chris Newcomer', is written over a horizontal line.

Chris Newcomer  
President

Please mail letter and drawings to:

Super 8 - Room #226  
Attention: Brian Newcomer  
208 Larrabee Rd  
Westbrook, ME 04092  
207-854-1881

## Review of RTU Loads for Replacement with New Units

Project Name: Home Depot (Store #2401) Portland, ME  
 Project Number: 2011-254

Location: Main Building Roof  
 Designer: SM

RTU No.	Existing Units			New Unit				
	Tonnage	RTU Type	RTU Serial #	WEIGHT	Tonnage	RTU Type	RTU Serial #	WEIGHT
1,5,9	20	AAON	RH-20-3-E0-232	3,100	20	LENNOX	LGH240H4B	2,716
4,6	20	AAON	RH-20-3-E0-232	3,100	20	LENNOX	LGH240H4B	2,716
3,7,8	20	AAON	RH-20-3-E0-000	3,100	20	LENNOX	LCH240H4B	2,571
2	20	AAON	RH-20-3-E0-000	3,100	20	LENNOX	LCH240H4B	2,571
11,13	24	AAON	RH-24-3-E0-232	3,100	25	LENNOX	LGC300H4B	3,340
10,12	24	AAON	RH-24-3-E0-232	3,100	25	LENNOX	LGC300H4B	3,340
14	2	AAON	RH-02-3-E0-231	1,100	5	LENNOX	LGH060H4E	883
15	2	AAON	RH-02-3-E0-231	1,100	3	LENNOX	LGH036H4E	735
16	4	AAON	RH-04-3-E0-231	1,100	4	LENNOX	LGH048H4E	778
17	3	AAON	RH-03-3-E0-231	1,100	3	LENNOX	LGH036H4E	735
UNIT HEATER				300		LENNOX	LFA24300A	305

RTU	Existing Wt shown on Drawing	Assumed Exist Curb Wt.	New Adapter Curb Wt.	New Total Wt	Add'l Wt. to Framing
1,5,9	3,100	230	513	3,459	129
4,6	3,100	230	513	3,459	129
3,7,8	3,100	230	513	3,314	0
2	3,100	230	513	3,314	0
11,13	3,100	230	513	4,083	753
10,12	3,100	230	513	4,083	753
14	1,100	230	220	1,333	3
15	1,100	230	220	1,185	0
16	1,100	230	220	1,228	0
17	1,100	230	220	1,185	0
UNIT HEATER	300			305	5



## Product Submittal

### Project Information

Project Name: THE HOME DEPOT # 2401

Project Number: 3000210778

Project Location: 245 RIVERSIDE STREET PORTLAND, ME 04103, US

Project Altitude: 75

### Customer Information

Company Name: Home Depot USA Inc

Company Address:

Company Location: Atlanta, GA

Contact: Greg Beesch

Phone: 770-433-8211

### Engineering Information

Company Name:

Company Address:

Company Location:

Contact:

Phone:

*We are pleased to provide the attached project submittal. If you have any questions or need additional information, please feel free to call our office.*

## Table of Contents

System ID	Qty	Model	Description
RTU 1,5,9	3	LGH240H4B	PKGGE/20TON/CONFIGURABLE
RTU 4,6	2	LGH240H4B	PKGGE/20TON/CONFIGURABLE
RTU 3,7,8	3	LCH240H4B	PKGEE/20TON/CONFIGURABLE
RTU 2	1	LCH240H4B	PKGEE/20TON/CONFIGURABLE
RTU 11,13	2	LGC300H4B	PKGGE/25TON/CONFIGURABLE
RTU 10,12	2	LGC300H4B	PKGGE/25TON/CONFIGURABLE
RTU 14	1	LGH060H4E	PKGGE/5TON/CONFIGURABLE
RTU 15,17	2	LGH036H4E	PKGGE/3TON/CONFIGURABLE
RTU 16	1	LGH048H4E	PKGGE/4TON/CONFIGURABLE
TRC SPLIT SYSTEM	1	XC14-060-230	CONDENSER/5TON/230-1
	1	CH33-50/60C-2F	COIL/4-5TON/CASED
	1	EL195UH090P60C	FURNACE-GAS/90BTUH/5TON
UNIT HEATERS	11	LF24-300A	UNIT HEATER

# Lennox Industries Inc. - Product Submittal

System ID: RTU 1,5,9

Package Model: LGH240H4B

Description: PKGGE/20TON/CONFIGURABLE

## DIMENSIONS - INCHES (MM)

### CORNER WEIGHTS

Model No.	AA		BB		CC		DD		EE		FF	
	lbs.	kg	lbs.	kg	lbs.	kg	lbs.	kg	in.	mm	in.	mm
LGH210 Std. Unit	497	234	513	242	671	317	649	306	54-3/4	1391	39-1/2	1003
LGH210 Max. Unit	607	286	598	282	700	330	710	335	53-1/2	1359	42	1067
LGH240 Std. Unit	507	239	533	252	713	336	677	320	55-1/4	1403	39	991
LGH240 Max. Unit	617	291	620	292	741	350	738	348	54	1372	41-1/2	1054
LGH300 Std. Unit	513	242	535	252	739	349	709	334	55	1397	38-1/4	972
LGH300 Max. Unit	623	294	620	293	767	362	770	363	53-3/4	1365	40-3/4	1035

Std. Unit - The unit with NO OPTIONS.

Max. Unit - The unit with ALL OPTIONS installed. (Economizer, etc.)

## LGH210, LGH240, LGH300

### CENTER OF GRAVITY

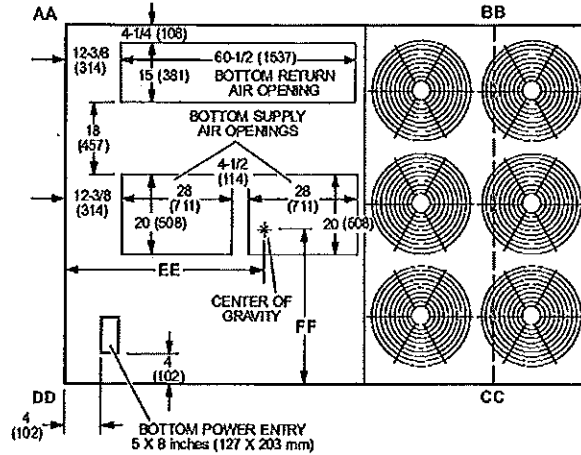

TOP VIEW

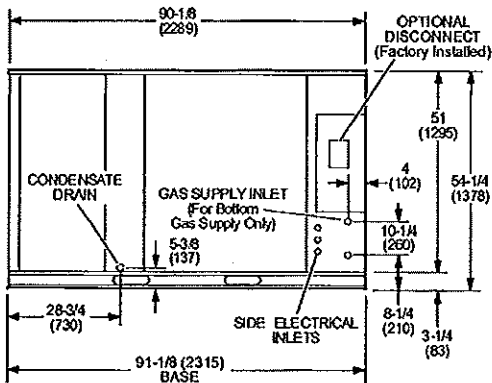

END VIEW

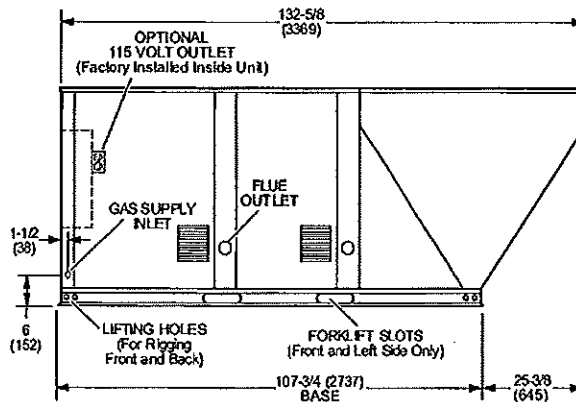

SIDE VIEW

# Lennox Industries Inc. - Product Submittal

System ID: RTU 1,5,9  
Package Model: LGH240H4B

Description: PKGGE/20TON/CONFIGURABLE

## ACCESSORY DIMENSIONS - INCHES (MM)

### OPTIONAL OUTDOOR AIR HOOD DETAIL WITH STANDARD STATIC POWER EXHAUST FANS

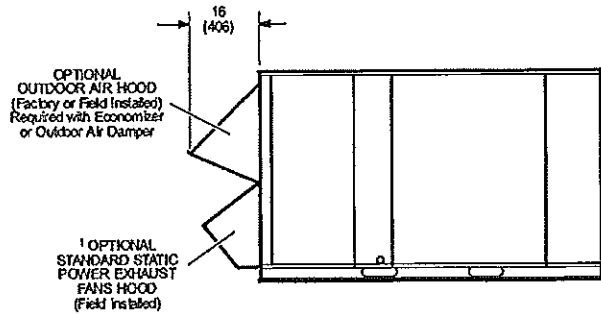

<sup>1</sup> Field Installed in Return Air Duct for Horizontal Applications.

### HORIZONTAL BAROMETRIC RELIEF DAMPERS (Field Installed in horizontal return air duct adjacent to unit)

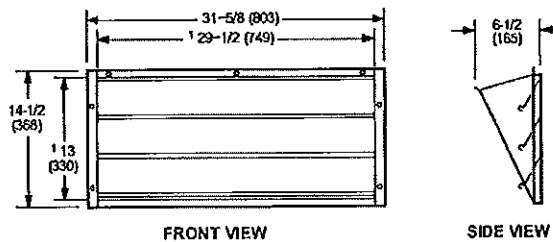

NOTE - Two furnished per order no.

<sup>1</sup> NOTE - Opening size required in return air duct

# Lennox Industries Inc. - Product Submittal

System ID: RTU 4,6

Package Model: LGH240H4B

Description: PKGGE/20TON/CONFIGURABLE

## DIMENSIONS - INCHES (MM) CORNER WEIGHTS

## LGH210, LGH240, LGH300 CENTER OF GRAVITY

Model No.	AA		BB		CC		DD		EE		FF	
	lbs.	kg	lbs.	kg	lbs.	kg	lbs.	kg	in.	mm	in.	mm
LGH210 Std. Unit	497	234	513	242	671	317	649	306	54-3/4	1391	39-1/2	1003
LGH210 Max. Unit	607	286	598	282	700	330	710	335	53-1/2	1359	42	1067
LGH240 Std. Unit	507	239	533	252	713	336	677	320	55-1/4	1403	39	991
→ LGH240 Max. Unit	617	291	620	292	741	350	738	348	54	1372	41-1/2	1054
LGH300 Std. Unit	513	242	535	252	739	349	709	334	55	1397	38-1/4	972
LGH300 Max. Unit	623	294	620	293	767	362	770	363	53-3/4	1365	40-3/4	1035

Std. Unit - The unit with NO OPTIONS.  
Max. Unit - The unit with ALL OPTIONS installed. (Economizer, etc.)

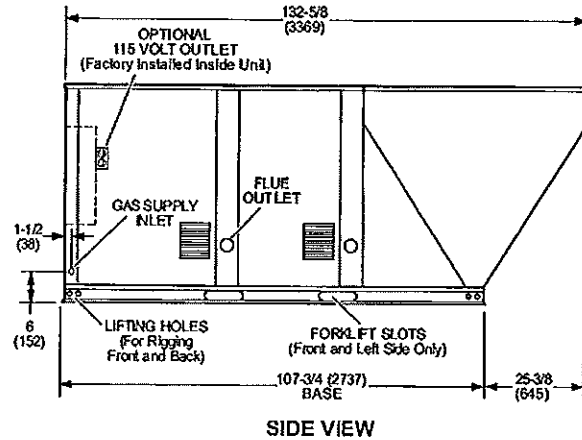
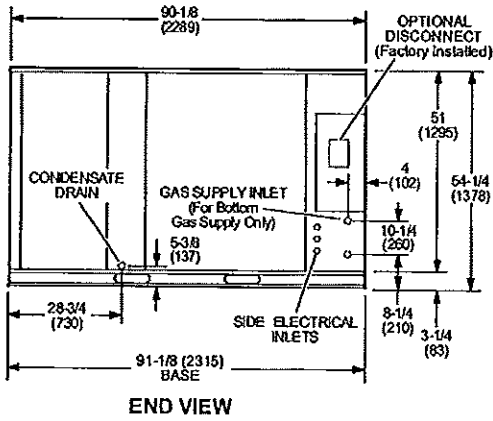
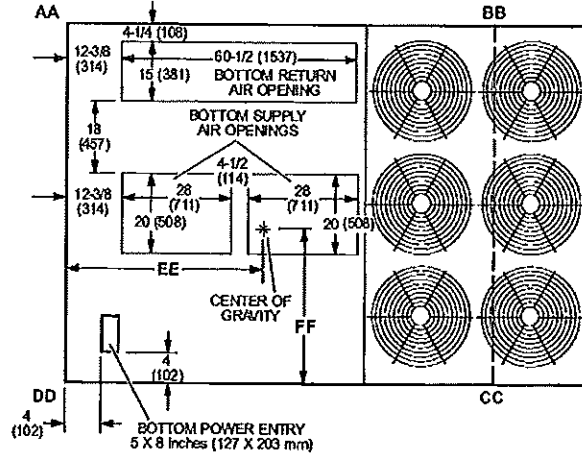

# Lennox Industries Inc. - Product Submittal

System ID: RTU 4,6  
 Package Model: LGH240H4B  
 Description: PKGGE/20TON/CONFIGURABLE

## ACCESSORY DIMENSIONS - INCHES (MM)

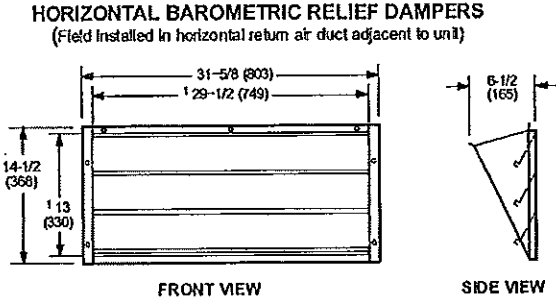
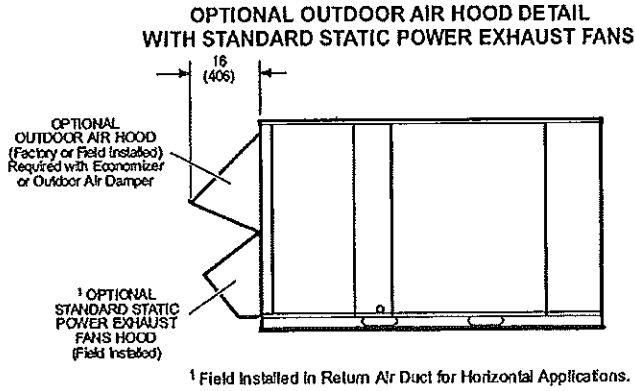

NOTE - Two furnished per order no.  
 1 NOTE - Opening size required in return air duct



# Lennox Industries Inc. - Product Submittal

System ID: RTU 3,7,8

Package Model: LCH240H4B

Description: PKGEE/20TON/CONFIGURABLE

## DIMENSIONS - INCHES (MM)

### CORNER WEIGHTS

Model No.	AA		BB		CC		DD		CENTER OF GRAVITY			
	lbs.	kg	lbs.	kg	lbs.	kg	lbs.	kg	in.	mm	in.	mm
LCH210 Std. Unit	452	213	493	233	645	304	590	279	56-1/4	1429	39-1/2	1003
LCH210 Max. Unit	557	263	581	274	680	321	652	308	55	1397	42	1067
LCH240 Std. Unit	462	218	514	243	687	324	617	291	56-3/4	1441	39	991
LCH240 Max. Unit	568	268	603	284	721	340	679	320	55-1/2	1410	41-1/2	1054
LCH300 Std. Unit	468	221	516	244	713	337	647	305	56-1/2	1435	38-1/4	972
LCH300 Max. Unit	574	271	604	285	747	352	710	335	55-1/4	1403	40-3/4	1035

Std. Unit - The unit with NO OPTIONS.  
 Max. Unit - The unit with ALL OPTIONS installed. (Economizer, etc.)

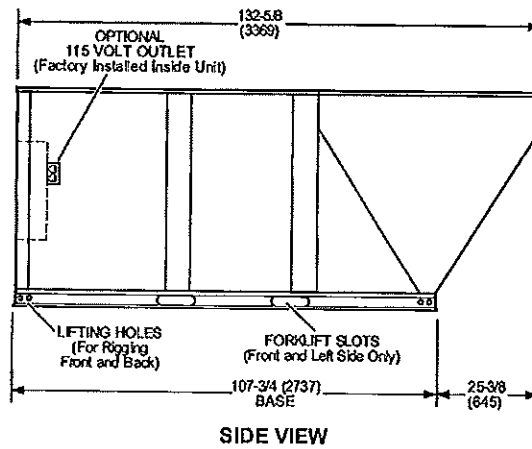
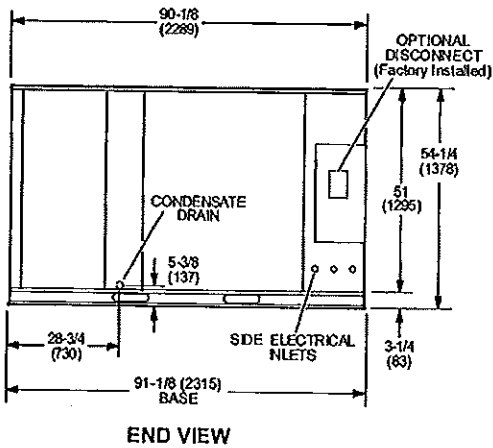
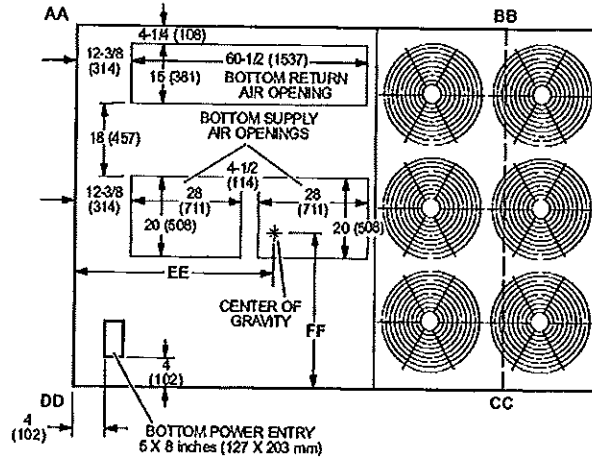

# Lennox Industries Inc. - Product Submittal

System ID: RTU 3,7,8

Package Model: LCH240H4B

Description: PKGEE/20TON/CONFIGURABLE

## ACCESSORY DIMENSIONS - INCHES (MM)

### OPTIONAL OUTDOOR AIR HOOD DETAIL WITH STANDARD STATIC POWER EXHAUST FANS

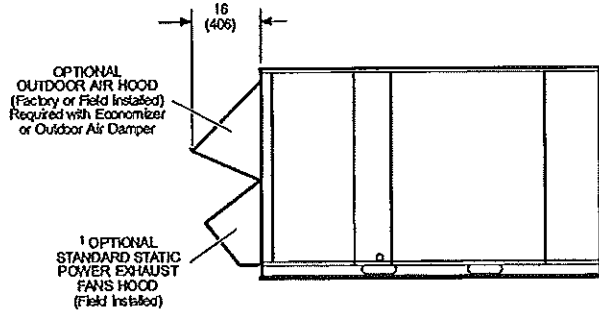

<sup>1</sup> Field Installed in Return Air Duct for Horizontal Applications.

### HORIZONTAL BAROMETRIC RELIEF DAMPERS (Field Installed in horizontal return air duct adjacent to unit)

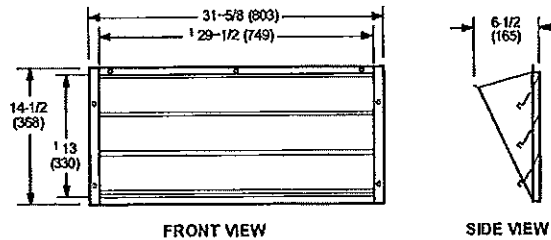

NOTE - Two furnished per order no.

<sup>1</sup> NOTE - Opening size required in return air duct.

# Lennox Industries Inc. - Product Submittal

System ID: RTU 2

Package Model: LCH240H4B

Description: PKGEE/20TON/CONFIGURABLE

## DIMENSIONS - INCHES (MM)

### CORNER WEIGHTS

Model No.	AA		BB		CC		DD		CENTER OF GRAVITY			
	lbs.	kg	lbs.	kg	lbs.	kg	lbs.	kg	in.	mm	in.	mm
	LCH210 Std. Unit	452	213	493	233	645	304	590	279	56-1/4	1429	39-1/2
LCH210 Max. Unit	557	263	581	274	680	321	652	308	55	1397	42	1067
LCH240 Std. Unit	462	218	514	243	687	324	617	291	56-3/4	1441	39	991
LCH240 Max. Unit	568	268	603	284	721	340	679	320	55-1/2	1410	41-1/2	1054
LCH300 Std. Unit	468	221	518	244	713	337	647	305	58-1/2	1435	38-1/4	972
LCH300 Max. Unit	574	271	604	285	747	352	710	335	55-1/4	1403	40-3/4	1035

Std. Unit - The unit with NO OPTIONS.

Max. Unit - The unit with ALL OPTIONS Installed. (Economizer, etc.)

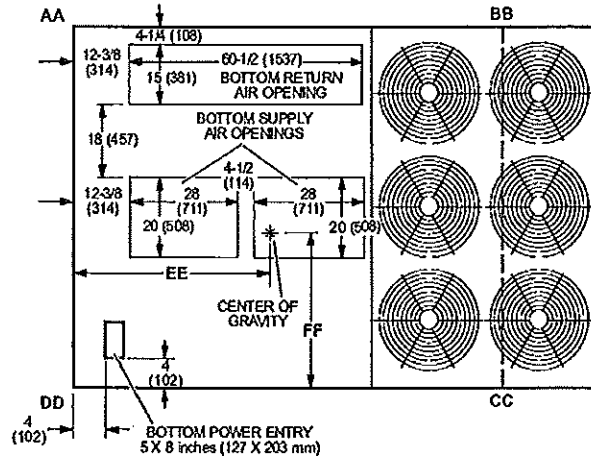

TOP VIEW

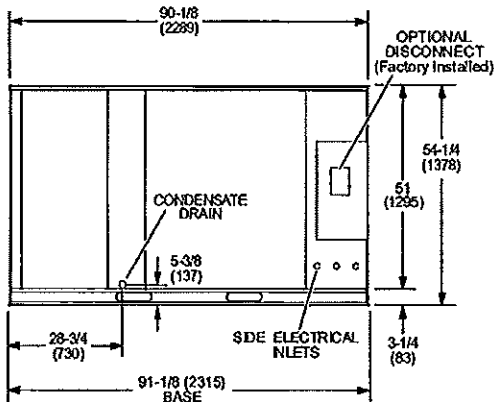

END VIEW

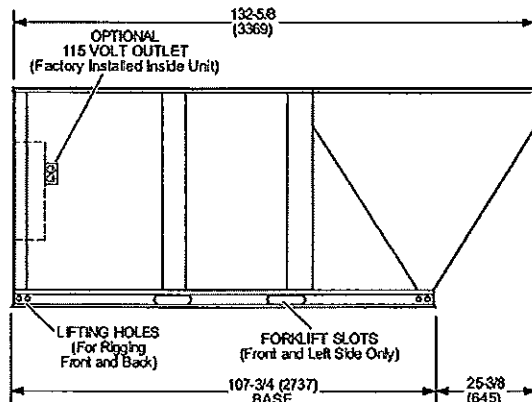

SIDE VIEW

# Lennox Industries Inc. - Product Submittal

System ID: RTU 2  
 Package Model: LCH240H4B  
 Description: PKGEE/20TON/CONFIGURABLE

## ACCESSORY DIMENSIONS - INCHES (MM)

### OPTIONAL OUTDOOR AIR HOOD DETAIL WITH STANDARD STATIC POWER EXHAUST FANS

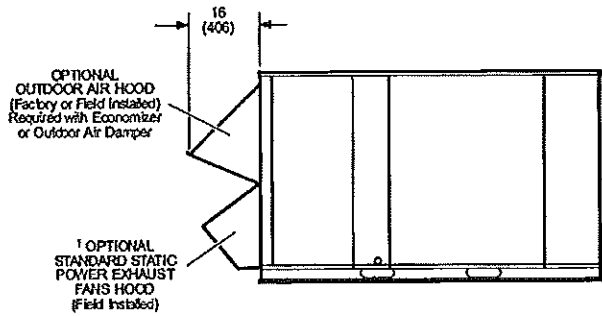

1 Field Installed in Return Air Duct for Horizontal Applications.

### HORIZONTAL BAROMETRIC RELIEF DAMPERS (Field Installed in horizontal return air duct adjacent to unit)

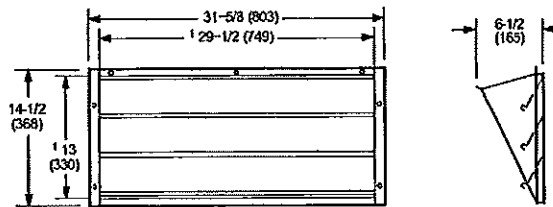

FRONT VIEW

SIDE VIEW

NOTE - Two furnished per order no.  
 1 NOTE - Opening size required in return air duct.

# Lennox Industries Inc. - Product Submittal

System ID: RTU 11,13

Package Model: LGC300H4B

Description: PKGGE/25TON/CONFIGURABLE

## DIMENSIONS - INCHES (MM)

Model Number	CORNER WEIGHTS								CENTER OF GRAVITY			
	AA		BB		CC		DD		EE		FF	
	lbs.	kg	lbs.	kg	lbs.	kg	lbs.	kg	inch	mm	inch	mm
All - Base Unit	588	267	630	286	932	423	870	395	62-5/8	1591	36-3/4	933
→ All - Max. Unit	716	325	743	337	958	335	923	419	61-1/4	1556	39-3/4	1010

Base Unit - The unit with low fire heat exchanger NO OPTIONS.

Max. Unit - The unit with ALL OPTIONS Installed. (High Input Heat Exchanger, Economizer, Standard Power Exhaust Fans, Controls)

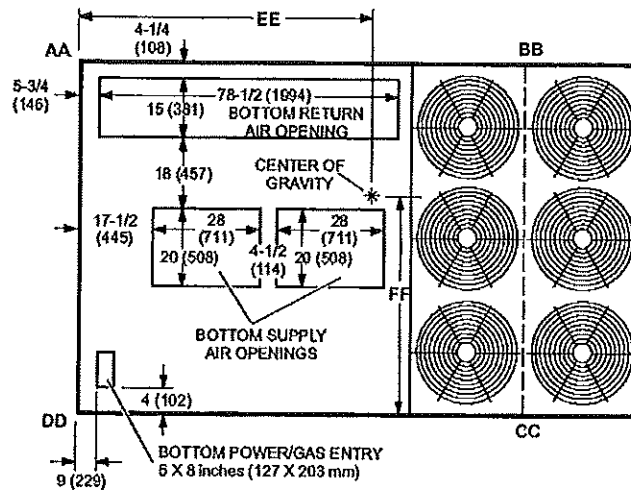

TOP VIEW

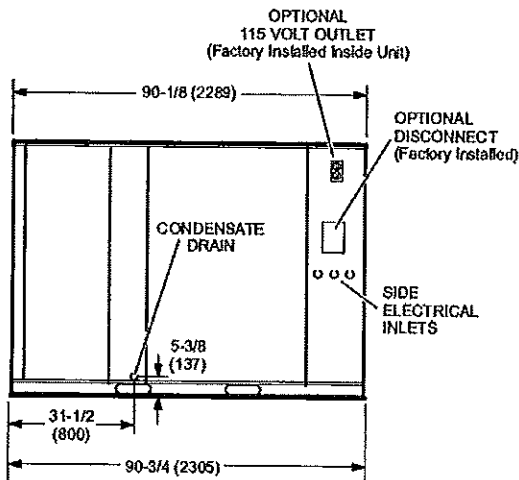

END VIEW

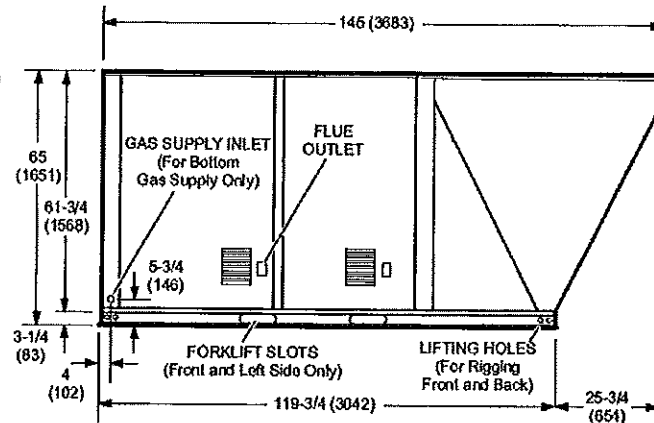

SIDE VIEW

# Lennox Industries Inc. - Product Submittal

System ID: RTU 11,13  
Package Model: LGC300H4B

Description: PKGGE/25TON/CONFIGURABLE

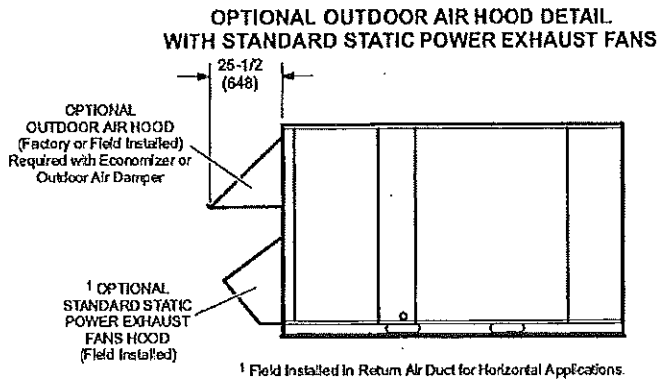

# Lennox Industries Inc. - Product Submittal

System ID: RTU 10,12

Package Model: LGC300H4B

Description: PKGGE/25TON/CONFIGURABLE

## DIMENSIONS - INCHES (MM)

Model Number	CORNER WEIGHTS								CENTER OF GRAVITY			
	AA		BB		CC		DD		EE		FF	
	lbs.	kg	lbs.	kg	lbs.	kg	lbs.	kg	inch	mm	inch	mm
All - Base Unit	588	267	630	286	932	423	870	395	62-5/8	1591	36-3/4	933
All - Max. Unit	716	325	743	337	958	335	923	419	61-1/4	1556	39-3/4	1010

Base Unit - The unit with low fire heat exchanger NO OPTIONS.

Max. Unit - The unit with ALL OPTIONS installed. (High Input Heat Exchanger, Economizer, Standard Power Exhaust Fans, Controls)

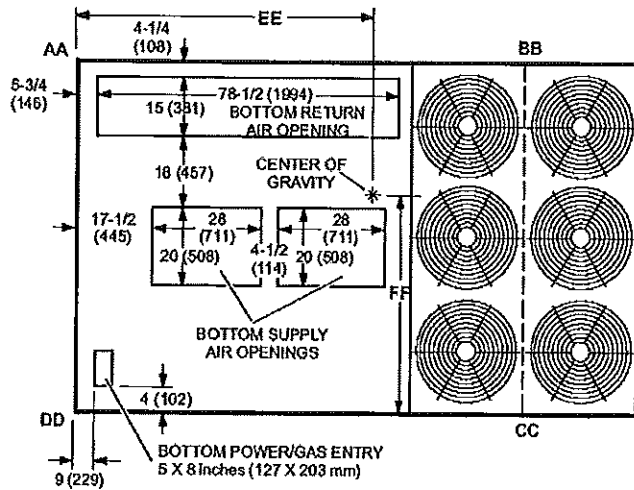

TOP VIEW

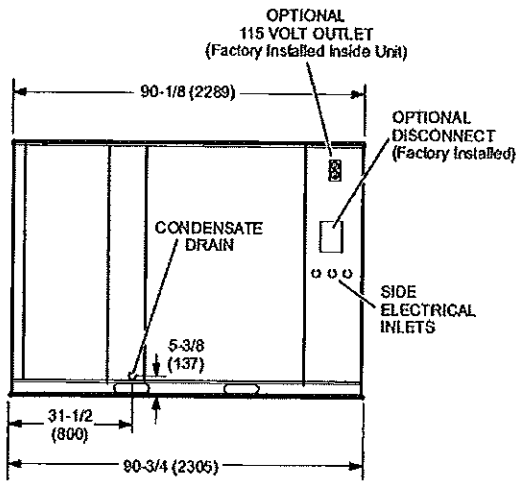

END VIEW

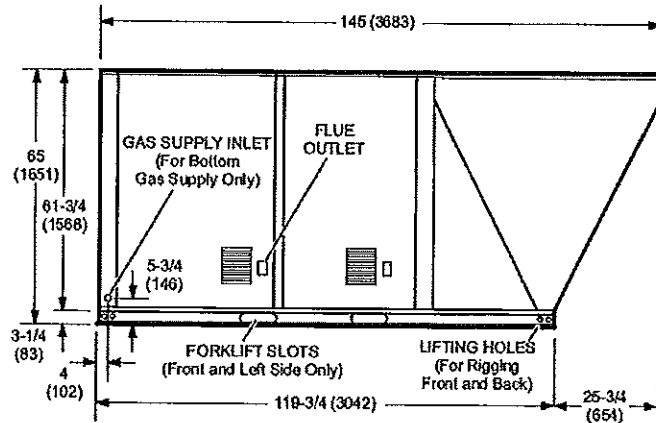

SIDE VIEW

# Lennox Industries Inc. - Product Submittal

System ID: RTU 10,12  
Package Model: LGC300H4B

Description: PKGGE/25TON/CONFIGURABLE

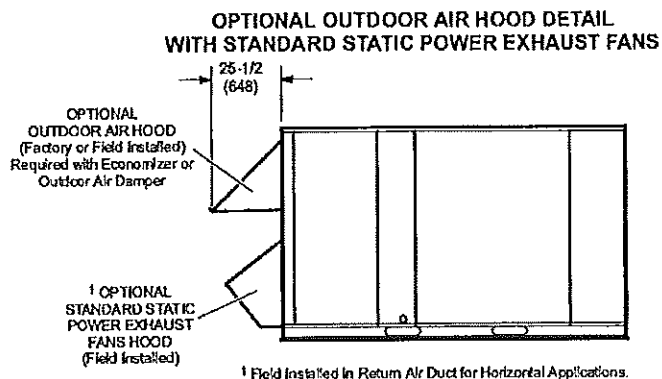



# Lennox Industries Inc. - Product Submittal

System ID: RTU 14

Package Model: LGH060H4E

Description: PKGGE/STON/CONFIGURABLE

## DIMENSIONS - INCHES (MM)

### CORNER WEIGHTS

Model No.	AA		BB		CC		DD		E CENTER OF GRAVITY		FF		GG		HH	
	lbs.	kg	lbs.	kg	lbs.	kg	lbs.	kg	in.	mm	in.	mm	in.	mm	in.	mm
LGH036 Std. Unit	98	45	119	54	192	87	158	72	38.5	978	18	457	29	737	46.76	1187
LGH036 Max. Unit	132	60	149	68	241	109	213	97	40	1016	18	457	29	737	45.26	1149
LGH048 Std. Unit	104	47	126	57	202	92	167	76	38.5	978	18	457	29	737	46.76	1187
LGH048 Max. Unit	140	64	158	72	255	116	225	102	40	1016	18	457	29	737	45.26	1149
LGH060 Std. Unit	118	54	144	65	232	105	191	87	38.5	978	18	457	29	737	46.76	1187
→ LGH060 Max. Unit	159	72	179	82	289	131	256	116	40	1016	18	457	29	737	45.26	1149
LGH072 Std. Unit	132	60	160	73	258	117	212	96	38.5	978	18	457	29	737	46.76	1187
LGH072 Max. Unit	167	76	189	86	305	138	269	122	40	1016	18	457	29	737	45.26	1149

Std. Unit - The unit with NO OPTIONS.

Max. Unit - The unit with ALL OPTIONS installed. (Economizer, etc.)

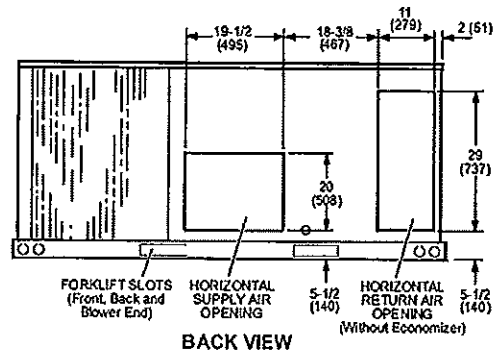
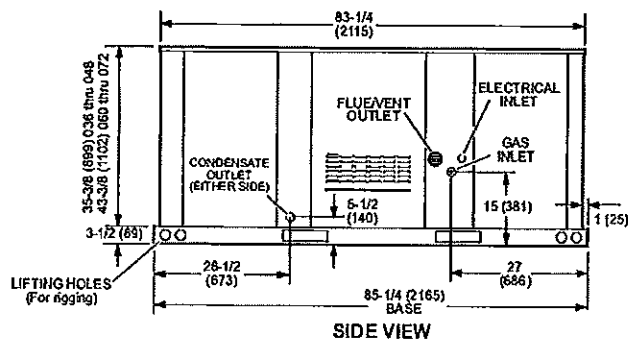
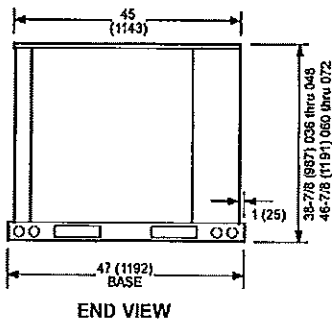
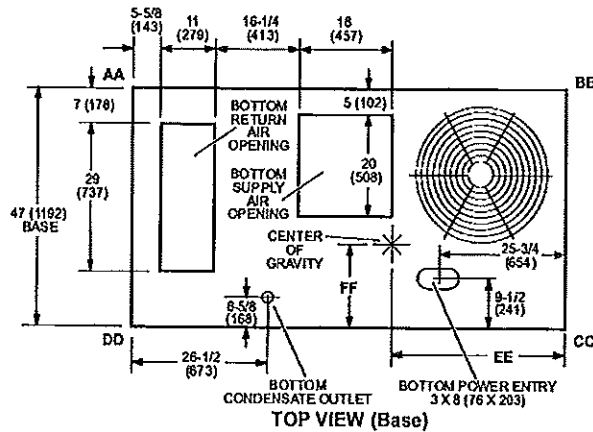

# Lennox Industries Inc. - Product Submittal

System ID: RTU 14

Package Model: LGH060H4E

Description: PKGGE/5TON/CONFIGURABLE

## ACCESSORY DIMENSIONS - INCHES (MM)

### OUTDOOR AIR HOOD DETAIL FOR OPTIONAL ECONOMIZER AND BAROMETRIC RELIEF DAMPERS (Down-Flow Applications)

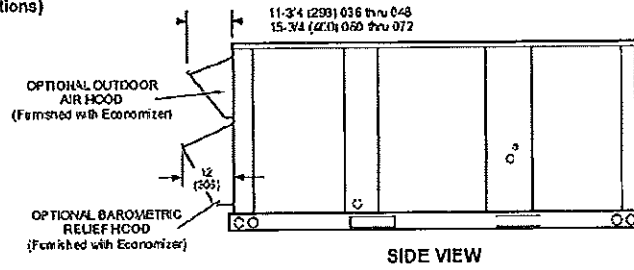

### OUTDOOR AIR HOOD FOR ECONOMIZER (Furnished)

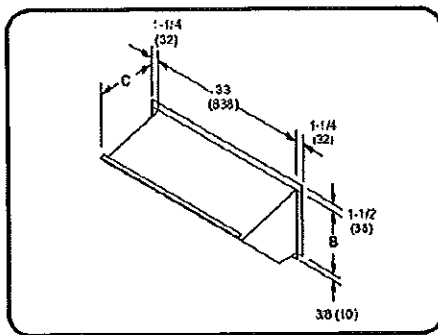

### BAROMETRIC RELIEF HOOD FOR ECONOMIZER (Furnished)

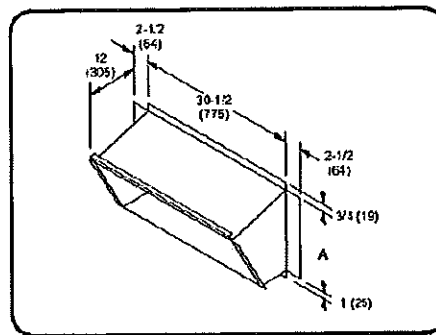

Model No.	A		B		C	
	in.	mm	in.	mm	in.	mm
036, 048	19-1/4	489	13	330	11-3/4	298
060, 072	23-1/4	591	17	432	15-3/4	400

# Lennox Industries Inc. - Product Submittal

System ID: RTU 15,17

Package Model: LGH036H4E

Description: PKGGE/3TON/CONFIGURABLE

## DIMENSIONS - INCHES (MM)

### CORNER WEIGHTS

Model No.	AA		BB		CC		DD		EE		FF		GG		HH	
	lbs.	kg	lbs.	kg	lbs.	kg	lbs.	kg	in.	mm	in.	mm	in.	mm	in.	mm
→ LGH036 Std. Unit	98	45	119	54	192	87	158	72	38.5	978	18	457	29	737	46.75	1187
LGH036 Max. Unit	132	60	149	68	241	109	213	97	40	1016	18	457	29	737	45.25	1149
LGH048 Std. Unit	104	47	128	57	202	92	167	76	38.5	978	18	457	29	737	46.75	1187
LGH048 Max. Unit	140	64	158	72	255	116	225	102	40	1016	18	457	29	737	45.25	1149
LGH060 Std. Unit	118	54	144	65	232	105	191	87	38.5	978	18	457	29	737	46.75	1187
LGH060 Max. Unit	159	72	179	82	289	131	256	116	40	1016	18	457	29	737	45.25	1149
LGH072 Std. Unit	132	60	160	73	258	117	212	96	38.5	978	18	457	29	737	46.75	1187
LGH072 Max. Unit	167	76	189	86	305	138	269	122	40	1016	18	457	29	737	45.25	1149

Std. Unit - The unit with NO OPTIONS.  
 Max. Unit - The unit with ALL OPTIONS Installed. (Economizer, etc.)

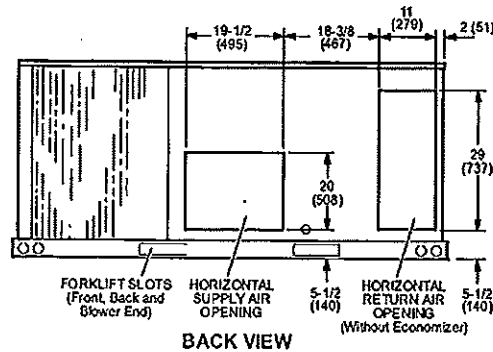
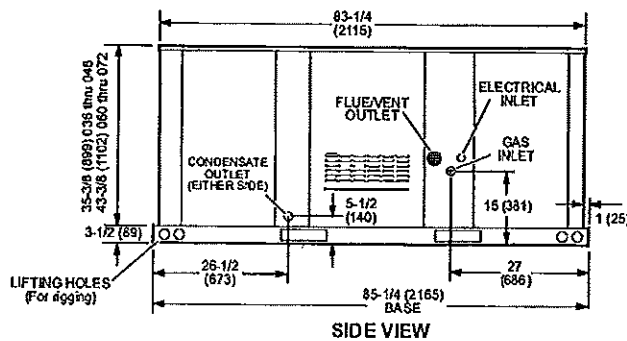
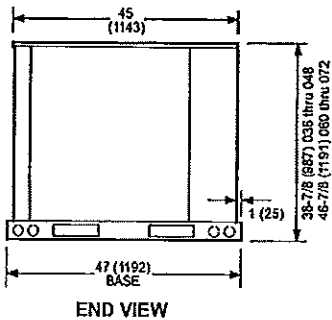
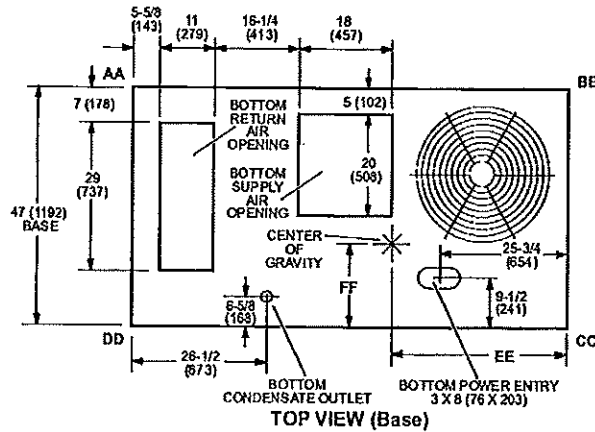

# Lennox Industries Inc. - Product Submittal

System ID: RTU 15,17

Package Model: LGH036H4E

Description: PKGGE/3TON/CONFIGURABLE

## ACCESSORY DIMENSIONS - INCHES (MM)

OUTDOOR AIR HOOD DETAIL FOR OPTIONAL ECONOMIZER AND BAROMETRIC RELIEF DAMPERS  
(Down-Flow Applications)

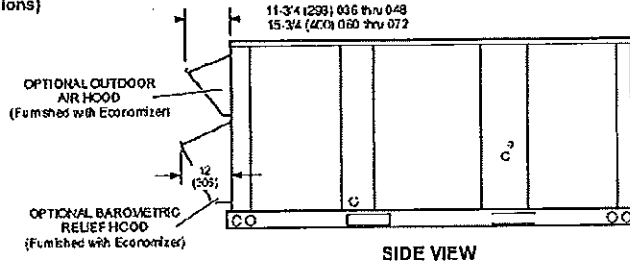

OUTDOOR AIR HOOD FOR ECONOMIZER (Furnished)

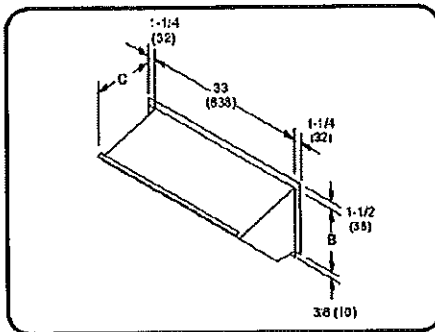

BAROMETRIC RELIEF HOOD FOR ECONOMIZER (Furnished)

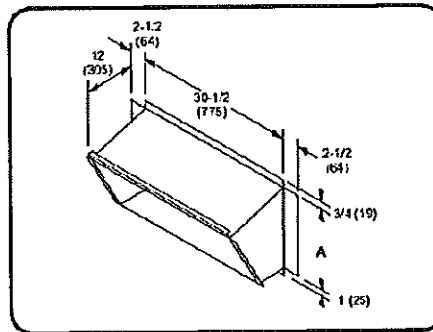

Model No.	A		B		C	
	in.	mm	in.	mm	in.	mm
036, 048	19-1/4	489	13	330	11-3/4	298
060, 072	23-1/4	591	17	432	15-3/4	400

# Innox Industries Inc. - Product Submittal

System ID: RTU 16

Package Model: LGH048H4E

Description: PKGGE/4TON/CONFIGURABLE

## DIMENSIONS - INCHES (MM)

### CORNER WEIGHTS

Model No.	AA		BB		CC		DD		E CENTER OF GRAVITY		FF		GG		HH	
	lbs.	kg	lbs.	kg	lbs.	kg	lbs.	kg	in.	mm	in.	mm	in.	mm	in.	mm
LGH036 Std. Unit	98	45	119	54	192	87	168	72	38.5	978	18	457	29	737	46.75	1187
LGH036 Max. Unit	132	60	149	68	241	109	213	97	40	1016	18	457	29	737	45.25	1149
LGH048 Std. Unit	104	47	126	57	202	92	167	76	38.5	978	18	457	29	737	46.75	1187
LGH048 Max. Unit	140	64	158	72	255	116	225	102	40	1016	18	457	29	737	45.25	1149
LGH060 Std. Unit	118	54	144	65	232	105	191	87	38.5	978	18	457	29	737	46.75	1187
LGH060 Max. Unit	159	72	179	82	289	131	256	116	40	1016	18	457	29	737	45.25	1149
LGH072 Std. Unit	132	60	160	73	258	117	212	96	38.5	978	18	457	29	737	46.75	1187
LGH072 Max. Unit	167	76	189	86	305	138	269	122	40	1016	18	457	29	737	45.25	1149

Std. Unit - The unit with NO OPTIONS.

Max. Unit - The unit with ALL OPTIONS installed. (Economizer, etc.)

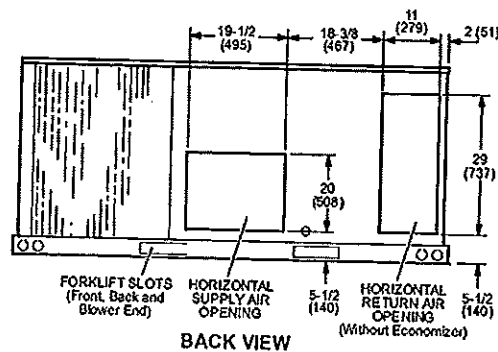
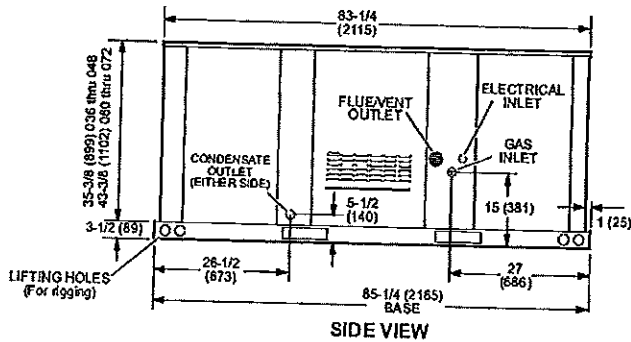
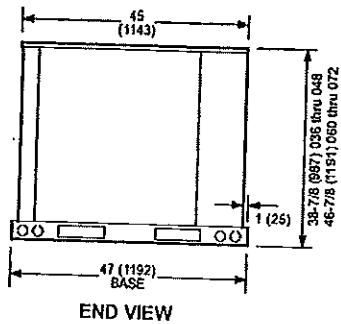
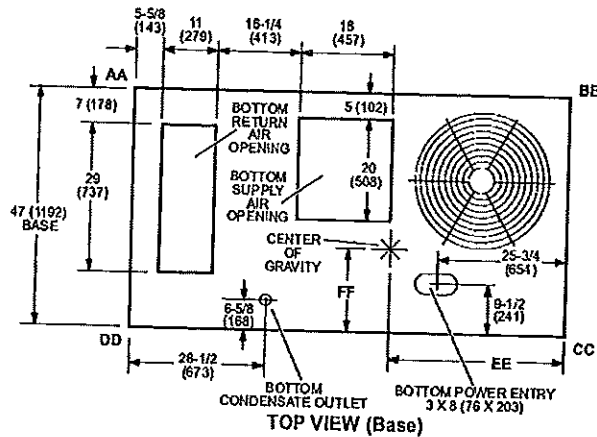

# Lennox Industries Inc. - Product Submittal

System ID: RTU 16

Package Model: LGH048H4E

Description: PKGGE/4TON/CONFIGURABLE

## ACCESSORY DIMENSIONS - INCHES (MM)

OUTDOOR AIR HOOD DETAIL FOR OPTIONAL ECONOMIZER AND BAROMETRIC RELIEF DAMPERS  
(Down-Flow Applications)

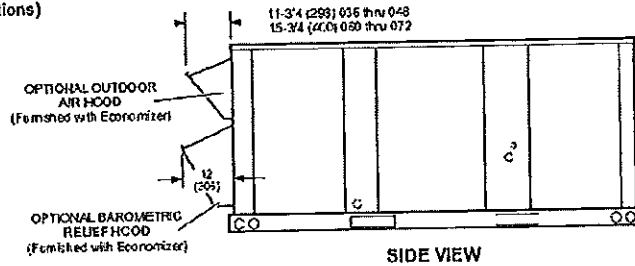

OUTDOOR AIR HOOD FOR ECONOMIZER  
(Furnished)

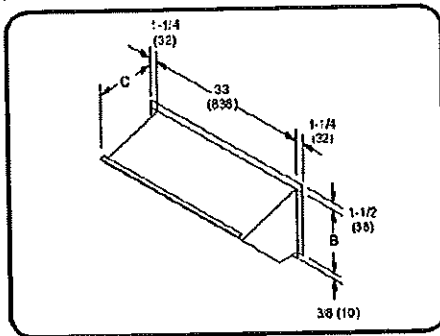

BAROMETRIC RELIEF HOOD FOR ECONOMIZER  
(Furnished)

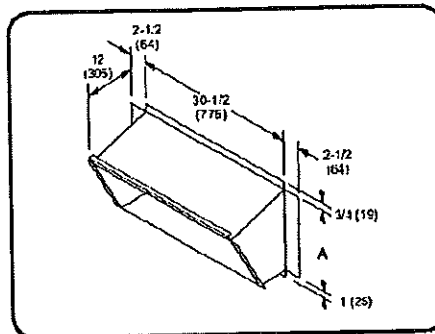

Model No.	A		B		C	
	in.	mm	in.	mm	in.	mm
036, 048	19-1/4	489	13	330	11-3/4	298
060, 072	23-1/4	591	17	432	15-3/4	400

# Lennox Industries Inc. - Product Submittal

System ID: TRC SPLIT SYSTEM  
 Condenser Model: XC14-060-230  
 Evaporator Coil Model: CH33-50/60C-2F  
 Furnace Model: EL195UH090P60C

Description: CONDENSER/5TON/230-1  
 Description: COIL/4-5TON/CASED  
 Description: FURNACE-GAS/90BTUH/STON

## DIMENSIONS - INCHES (MM)

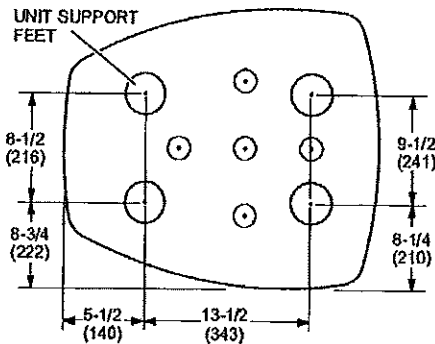
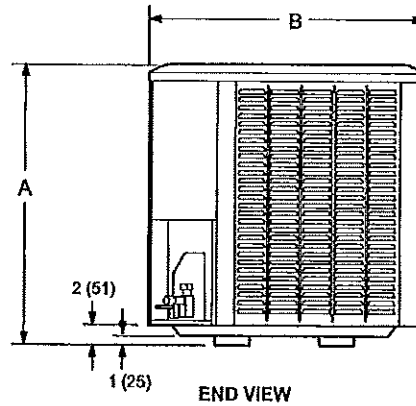
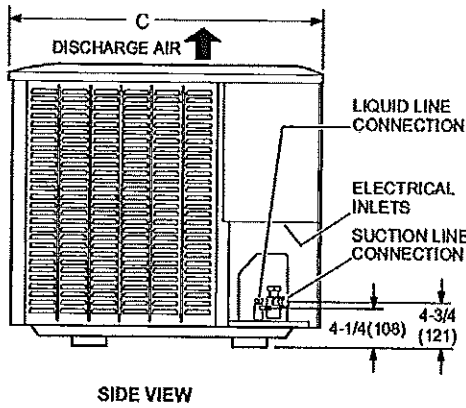
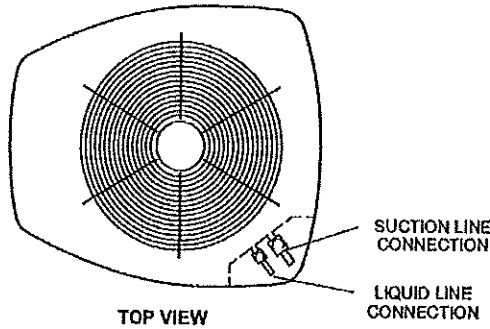

XC14-018-024 BASE SECTION

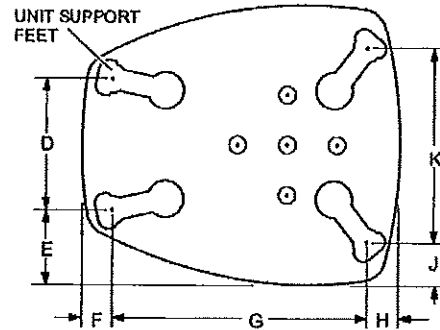

XC14-030 TO -60 BASE SECTION

Model No.	A		B		C		D		E		F		G		H		J		K	
	in.	mm	in.	mm	in.	mm	in.	mm	in.	mm	in.	mm	in.	mm	in.	mm	in.	mm	in.	mm
XC14-018	31	787	27	686	28	711	---	---	---	---	---	---	---	---	---	---	---	---	---	---
XC14-024																				
XC14-030	31	787	30-1/2	775	35	889	13-7/8	352	7-3/4	197	3-1/4	83	27-1/8	689	3-5/8	92	4-1/2	114	20-5/8	524
XC14-036																				
XC14-042																				
XC14-048	39	991	30-1/2	775	35	889	13-7/8	352	7-3/4	197	3-1/4	83	27-1/8	689	3-5/8	92	4-1/2	114	20-5/8	524
XC14-060	35	889	35-1/2	902	39-1/2	1003	16-7/8	429	8-3/4	222	3-1/8	79	30-3/4	781	4-5/8	117	3-3/4	95	26-7/8	683

# Lennox Industries Inc. - Product Submittal

System ID: TRC SPLIT SYSTEM  
 Condenser Model: XC14-060-230  
 Evaporator Coil Model: CH33-50/60C-2F  
 Furnace Model: EL195UH090P60C

Description: CONDENSER/5TON/230-1  
 Description: COIL/4-5TON/CASED  
 Description: FURNACE-GAS/90BTUH/5TON

## DIMENSIONS - INCHES (MM)

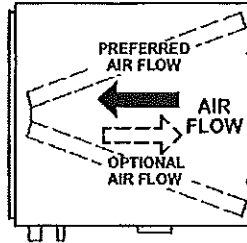

TOP VIEW

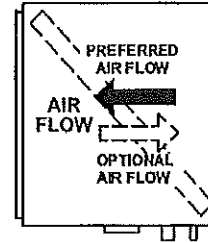

TOP VIEW  
CH33-18A

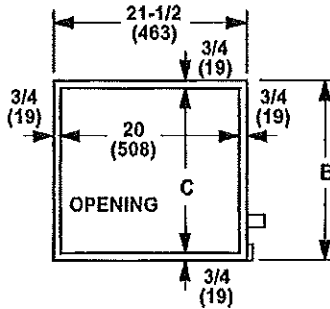

END VIEW

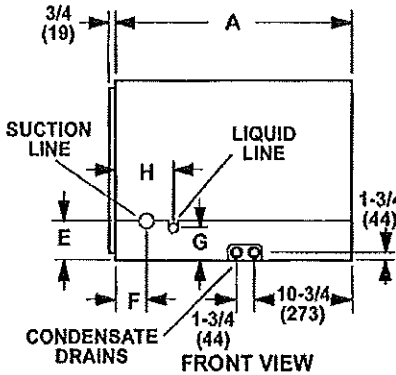

FRONT VIEW

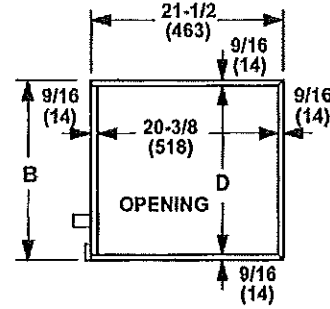

END VIEW

Model No.	A		B		C		D		E		F		G		H	
	in.	mm	in.	mm	in.	mm	in.	mm	in.	mm	in.	mm	in.	mm	in.	mm
CH33-18A-2F	21-1/2	546	14-1/2	368	13	330	13-3/8	340	3-3/4	95	3-1/4	83	2-3/4	70	1-3/4	44
CH33-19A-2F	26-1/2	673	14-1/2	368	13	330	13-3/8	340	4	102	2-1/8	54	3	76	4-7/8	124
CH33-24/30A-2F	26-1/2	673	14-1/2	368	13	330	13-3/8	340	4	102	2-1/8	54	3	76	4-7/8	124
CH33-25A-2F	26-1/2	673	14-1/2	368	13	330	13-3/8	340	4	102	2-1/8	54	3	76	4-7/8	124
CH33-25B-2F	26-1/2	673	17-1/2	444	16	406	16-3/8	416	4	102	2-1/8	54	3	76	4-7/8	124
CH33-31A-2F	31-1/2	800	14-1/2	368	13	330	13-3/8	340	4	102	2-1/8	54	3	76	4-7/8	124
CH33-31B-2F	26-1/2	673	17-1/2	444	16	406	16-3/8	416	4	102	2-1/8	54	3	76	4-7/8	124
CH33-36A-2F	26-1/2	673	14-1/2	368	13	330	13-3/8	340	4	102	2-1/8	54	3	76	4-7/8	124
CH33-36B-2F	26-1/2	673	17-1/2	444	16	406	16-3/8	416	4	102	2-1/8	54	3	76	4-7/8	124
CH33-36C-2F	26-1/2	673	21	533	19-1/2	495	19-7/8	505	4	102	2-1/8	54	3	76	4-7/8	124
CH33-42B-2F	26-1/2	673	17-1/2	444	16	406	16-3/8	416	4	102	2-1/8	54	3	76	4-7/8	124
CH33-43B-2F	31-1/2	800	17-1/2	444	16	406	16-3/8	416	4	102	2-1/8	54	3	76	4-7/8	124
CH33-43C-2F	26-1/2	673	21	533	19-1/2	495	19-7/8	505	4	102	2-1/8	54	3	76	4-7/8	124
CH33-44/48B-2F	31-1/2	800	17-1/2	444	16	406	16-3/8	416	4	102	2-1/8	54	3	76	4-7/8	124
CH33-48C-2F	26-1/2	673	21	533	19-1/2	495	19-7/8	505	4	102	2-1/8	54	3	76	4-7/8	124
CH33-49C-2F	31-1/2	800	21	533	19-1/2	495	19-7/8	505	4	102	2-1/8	54	3	76	4-7/8	124
CH33-50/60C-2F	31-1/2	800	21	533	19-1/2	495	19-7/8	505	4	102	2-1/8	54	3	76	4-7/8	124
CH33-60D-2F	26-1/2	673	24-1/2	622	23	584	23-3/8	594	4	102	2-1/8	54	3	76	4-7/8	124
CH33-62D-2F	31-1/2	800	24-1/2	622	23	584	23-3/8	594	4	102	2-1/8	54	3	76	4-7/8	124



# LF24 UNIT HEATER PERFORMANCE SPECIFICATIONS

Model*	GAS HEATING PERFORMANCE				CONNECTIONS			FAN DATA					PHYSICAL DATA			
	Heating Capacity Input Btu/h (kW)	Heating Output Btu/h (kW)	Steady State Efficiency	Temp. Rise °F (°C)	Vert. Flue Size Round Inches (mm)	Horiz. Flue Size Round Inches (mm)	Gas Piping Size Inches (NPT)	Number of Fans	Diameter Inches (mm)	Number of Blades	Motor Output hp (W)	Motor Full Load Amps	Motor RPMs	Air Vol. CFM (L/s)	Dimensions H x W x L (Inches)	Ship Wt. (lbs.)
LF24-30A	30,000 (8.8)	24,300 (7.1)	81.0%	42 (23)	3 (76)	4 (102)	1/2	1	10 (254)	4	1/20 (37)	1.7	1650	535 (250)	13 x 25 x 24	60
LF24-45A	45,000 (13.2)	36,500 (10.7)	81.0%	45 (25)	3 (76)	4 (102)	1/2	1	10 (254)	4	1/20 (37)	1.7	1650	750 (355)	13 x 25 x 24	63
LF24-60A	60,000 (17.6)	48,000 (14.1)	80.0%	55 (31)	4 (102)	5 (127)	1/2	1	14 (356)	3	1/10 (29)	4.1	1050	830 (390)	18 x 25 x 25	87
LF24-75A	75,000 (22.0)	60,000 (17.6)	80.0%	60 (33)	4 (102)	5 (127)	1/2	1	14 (356)	3	1/10 (29)	4.1	1050	950 (450)	18 x 25 x 25	91

\*A denotes aluminum steel heat exchanger. All models are 115 volts, 60 hertz, 1 phase.  
 †2-1/8 x 3 in. (54 x 76 mm) diameter adaptor is furnished with unit for flue connection.  
 ‡2 x 4 in. (51 x 102 mm) diameter adaptor is furnished with unit for flue connection.  
 §3 x 4 in. (76 x 102 mm) vent adaptor required (not furnished) for horizontal venting in residential applications.  
 ¶4 x 5 in. (102 x 127 mm) vent adaptor required (not furnished) for horizontal venting in residential applications.

Model*	GAS HEATING PERFORMANCE				CONNECTIONS			FAN DATA					PHYSICAL DATA			
	Heating Capacity Input Btu/h (kW)	Output Natural Btu/h (kW)	Output LPG Propane Btu/h (kW)	Steady State Efficiency Natural	LPG Propane	Flue Size Round Inches (mm)	Gas Piping Size Inches (NPT)	Number of Fans	Diameter Inches (mm)	Number of Blades	Number of Motors	Motor Output hp (W)	Motor Full Load Amps (total)	Air Vol. CFM (L/s)	Dimensions H x W x L (Inches)	Ship Wt. (lbs.)
LD24-100S	100,000 (29.3)	80,500 (23.6)	82,000 (24.0)	80.5%	82.0%	4 (102)	1/2	1	16 (406)	4	1	1/8 (93)	2.1	1900 (895)	32-3/16 x 20-3/16 x 39-3/16	140
LD24-100A	115,000 (33.7)	92,000 (27.0)	92,000 (27.0)	80.0%	80.0%	4 (102)	1/2	1	16 (406)	4	1	1/8 (93)	2.1	1900 (895)	32-3/16 x 20-3/16 x 39-3/16	140
LD24-135S	143,750 (42.1)	115,000 (33.7)	115,000 (33.7)	80.0%	80.0%	4 (102)	1/2	1	16 (406)	5	1	1/8 (93)	2.1	1900 (895)	32-3/16 x 20-3/16 x 39-3/16	150
LD24-145S	172,500 (50.5)	138,000 (40.4)	138,000 (40.4)	80.0%	80.0%	5 (127)	1/2	1	16 (406)	5	1	1/8 (93)	2.1	2200 (1035)	32-3/16 x 23-1/8 x 39-3/16	165
LD24-200S	195,000 (56.9)	156,000 (45.6)	156,000 (45.6)	80.0%	80.0%	5 (127)	1/2	1	16 (406)	5	1	1/8 (93)	2.1	2200 (1035)	32-3/16 x 41-1/8 x 40	175
LD24-230S	230,000 (67.3)	184,000 (53.9)	184,000 (53.9)	80.0%	80.0%	6 (152)	3/4	2	16 (406)	5	2	1/8 (93)	4.2	4400 (2075)	32-3/16 x 41-1/8 x 40	260
LD24-250S	250,000 (73.3)	201,250 (59.0)	205,000 (60.1)	80.5%	82.0%	5 (127)	3/4	2	16 (406)	5	2	1/8 (93)	4.2	4400 (2075)	32-3/16 x 41-1/8 x 40	285
LD24-300S	300,000 (87.9)	241,500 (70.8)	246,000 (72.1)	80.5%	82.0%	5 (127)	3/4	2	16 (406)	5	2	1/8 (93)	4.2	4400 (2075)	32-3/16 x 41-1/8 x 40	305
LD24-345S	345,000 (101.1)	276,000 (80.9)	281,200 (82.4)	80.0%	81.5%	6 (152)	3/4	2	16 (406)	5	2	1/8 (93)	4.2	4400 (2075)	32-3/16 x 41-1/8 x 41-1/8	310
LD24-400S	390,000 (114.3)	312,000 (91.4)	312,000 (91.4)	80.0%	80.0%	6 (152)	3/4	2	16 (406)	5	2	1/8 (93)	4.2	4400 (2075)	32-3/16 x 41-1/8 x 41-1/8	315

\*S denotes stainless steel heat exchanger. A denotes aluminum steel heat exchanger. All models are 115 volts, 60 hertz, 1 phase.  
 †2-1/8 x 4 in. (54 x 102 mm) diameter adaptor is furnished with unit for flue connection.  
 ‡2-1/4 x 2-3/4 in. (57 x 70 mm) rectangular to 5 in. (127 mm) round adaptor is furnished with unit for flue connection.  
 §2-1/4 x 2-3/4 in. (57 x 70 mm) rectangular to 6 in. (152 mm) round adaptor is furnished with unit for flue connection.

# LD24 DUCT FURNACE PERFORMANCE SPECIFICATIONS

Model*	GAS HEATING PERFORMANCE				CONNECTIONS			FAN DATA		PHYSICAL DATA	
	Heating Capacity Input Btu/h (kW)	Heating Output Btu/h (kW)	Steady State Efficiency	Temp. Rise °F (°C)	Flue Size Round Inches (mm)	Gas Piping Size Inches (NPT)	Cond. Drain Size Inches (mm)	Air Vol. Throughput CFM (L/s)	Dimensions H x W x L (Inches)	Ship Wt. (lbs.)	
LD24-75S	75,000 (22.0)	60,000 (17.6)	80.0%	21-71 (12-40)	4 (102)	1/2	1/4 (6)	790-2700 (370-1275)	28.5 x 125 x 19.5 x 34.6875	95	
LD24-100S	100,000 (29.3)	80,000 (23.4)	80.0%	20-85 (11-47)	4 (102)	1/2	1/4 (6)	870-3700 (410-1745)	32-1875 x 20-1875 x 40	130	
LD24-125S	125,000 (36.6)	100,000 (29.3)	80.0%	20-91 (11-50)	4 (102)	1/2	1/4 (6)	1020-4700 (480-2220)	32-1875 x 20-1875 x 40	135	
LD24-150S	150,000 (44.0)	120,000 (35.1)	80.0%	20-84 (11-47)	4 (102)	1/2	1/4 (6)	1320-5600 (625-2645)	32-1875 x 23-125 x 40	150	
LD24-200S	200,000 (58.6)	160,000 (46.8)	80.0%	35-100 (19-57)	5 (127)	3/4	1/4 (6)	1480-4230 (700-1995)	32-1875 x 41-125 x 40	245	
LD24-250S	250,000 (73.3)	200,000 (58.6)	80.0%	35-100 (19-57)	5 (127)	3/4	1/4 (6)	1850-5290 (875-2495)	32-1875 x 41-125 x 40	260	
LD24-300S	300,000 (87.9)	240,000 (70.3)	80.0%	36-100 (20-57)	5 (127)	3/4	1/4 (6)	2220-6200 (1050-2925)	32-1875 x 41-125 x 40	275	

\*S denotes stainless steel heat exchanger. A denotes aluminum steel heat exchanger. All models are 115 volts, 60 hertz, 1 phase.  
 †2-1/8 x 4 in. (57 x 102 mm) round flue adaptor is furnished with unit for flue connection.  
 ‡2-1/4 x 2-3/4 in. (57 x 70 mm) rectangular to 5 in. (127 mm) round adaptor is furnished with unit for flue connection.

Note: Due to Lennox' ongoing commitment to quality, all specifications, ratings and dimensions are subject to change.

Drawing Date: 5-27-09	REV: 002 2-15-11	Approved By:
SHELL: 14 GA	PANS: 18 GA	CHANNELS: 14 GA
		CLOSURES: 12 GA
		TOP FLANGE DIM: 1 1/2"

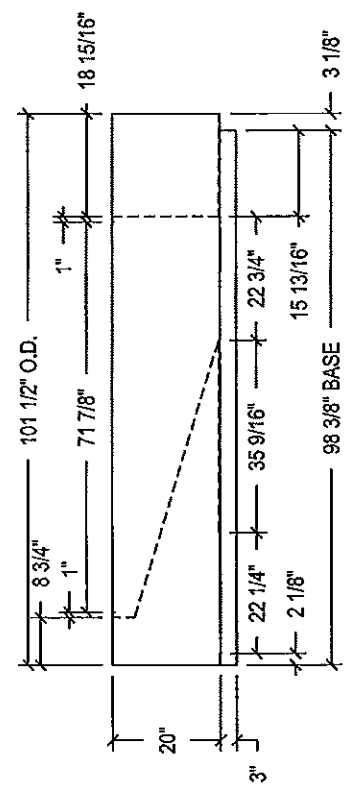
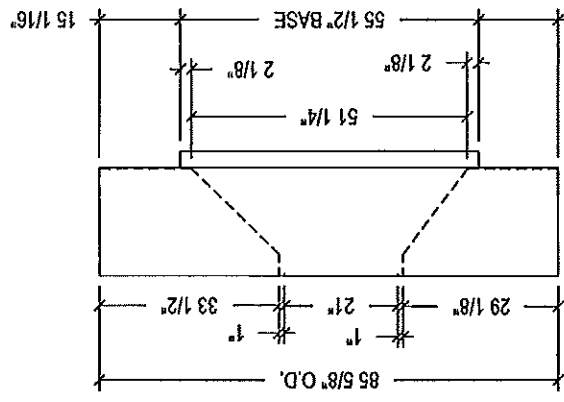

QTY: 9	DRAWN BY: SLR
NEW UNIT: LENNOX	
L/T/K SERIES: LGH-LCH 156-360	
OLD UNIT: AAON	
RK/RH/RE 16-25 & 30 TON	
ROLLS OF GASKET: 2	
TAG: RTU-1-9	

**CURBS PLUS, INC.**  
**TRANSITION-CURB SYSTEM**

Confidential and proprietary information of Curbs Plus, Inc. unauthorized use, disclosure, or reproduction is expressly prohibited.

TAG PLATE: LX8AA126/LX111AA126  
 APPROXIMATE WEIGHT: 513 LBS \*

1200 Carline Rd.  
 Rossville, GA 30741  
 Phone: (706) 858-1188 / Fax: (706) 866-2339  
 website: www.curbs-plus.com

Note: Design subject to change without notice. File Name: LX8AA126-0 LX111AA126-0 NEW LENNOX L-SERIES 156-360 EXISTING AAON C-CABENIT ©2003 Curbs Plus, Inc.

Drawing Date: 4-6-10	REV: 001	Approved By:
SHELL: 14 GA	PANS: 18 GA	CHANNELS: 14 GA
		CLOSURES: 12 GA
		TOP FLANGE DIM: 1 1/2"

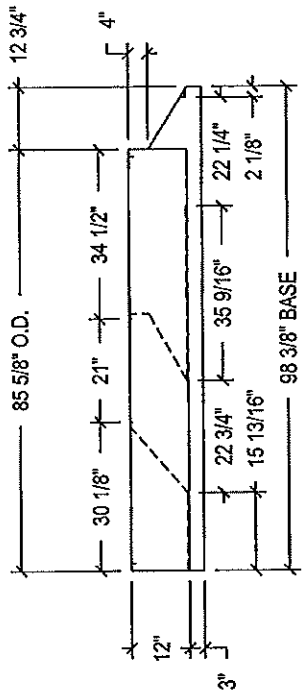
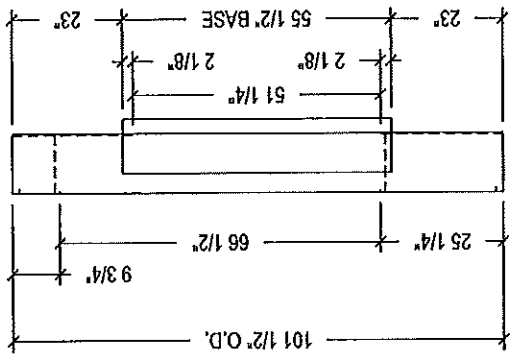
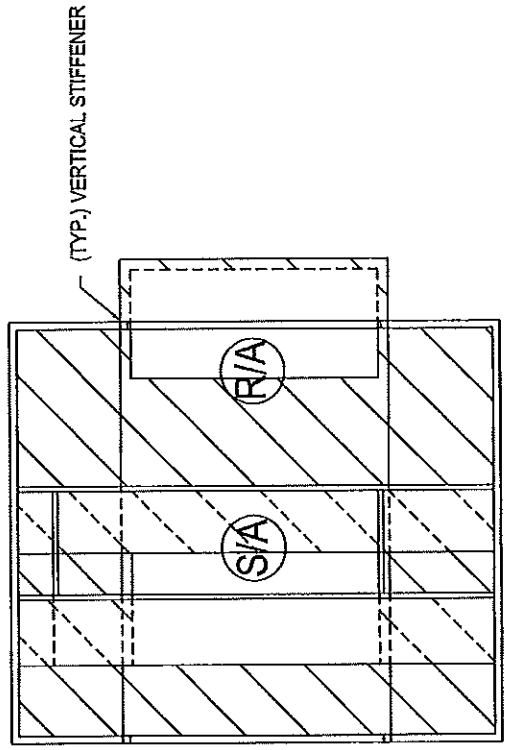

QTY: 4	DRAWN BY: SLW
NEW UNIT: LENNOX	
L/T/K-SERIES/LGH-LCH 156-360	
OLD UNIT: AAO	
RK/RH/RE 16-25 TON	
ROLLS OF GASKET: 2	
TAG: RTU-10, 11, 12, 13	

**TRANSITION-CURB SYSTEM**  
 Confidential and proprietary information of Curbs Plus, Inc. Unauthorized use, disclosure, or reproduction is expressly prohibited.

TAG PLATE: LX8AA126-1/LX11AA126-1  
 APPROXIMATE WEIGHT:

**CURBS PLUS, INC.**  
 1200 Carline Rd.  
 Rossville, GA 30741  
 Phone: (706) 858-1188 / Fax: (706) 866-2339  
 website: www.curbs-plus.com

Note: Design subject to change without notice. File Name: LX8AA126-1 LX11AA126-1 NEW LENNOX L-SERIES 156-360 EXISTING AAO C-CABENIT ©2003 Curbs Plus, Inc.

Drawing Date: 5-29-08      REV: 001      Approved By:

SHELL: 16 GA.      PANS: 18 GA.      CHANNELS: 18 GA.      CLOSURES: 16 GA.      TOP FLANGE DIM: 1 1/2"

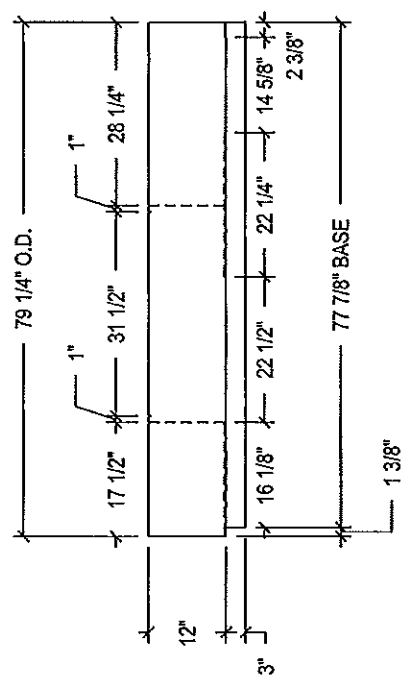
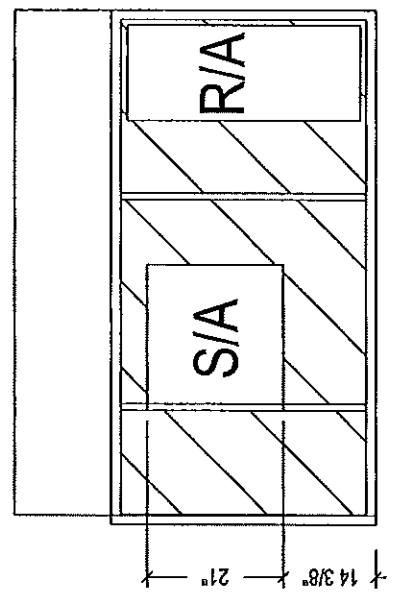
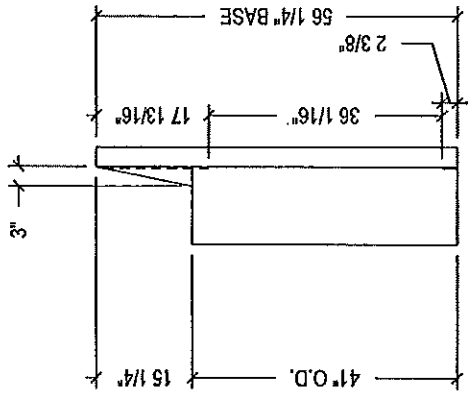

QTY: 4      DRAWN BY: SLW  
 NEW UNIT: LENNOX  
 T/K-SERIES 024-072/LGH-LCH 036-072 EMERGENCE  
 OLD UNIT: AAOON  
 A-BOX STANDARD 2-7 TON  
 ROLLS OF GASKET: 2  
 TAG: RTU-14, 15, 16, 17

**TRANSITION-CURB SYSTEM**  
Confidential and proprietary information of Curbs Plus, Inc. unauthorized use, disclosure, or reproduction is expressly prohibited.  
 TAG PLATE: LX108AA122  
 APPROXIMATE WEIGHT: 220 LBS. \*

**CURBS PLUS, INC.**  
 1200 Carline Rd.  
 Rossville, GA 30741  
 Phone: (706) 858-1188 / Fax: (706) 866-2339  
 website: www.curbs-plus.com

Note: Design subject to change without notice.      File Name: LX108AA122 NEW LENNOX T-SERIES 036-072 EXISTING AAOON 2-7 TON      ©2003 Curbs Plus, Inc.

Drawing Date: \_\_\_\_\_ REV: \_\_\_\_\_ Approved By: \_\_\_\_\_

Holes are punched for use with 3-style or adapter curbs

Holes in the top for use with adapters with no turn-downs

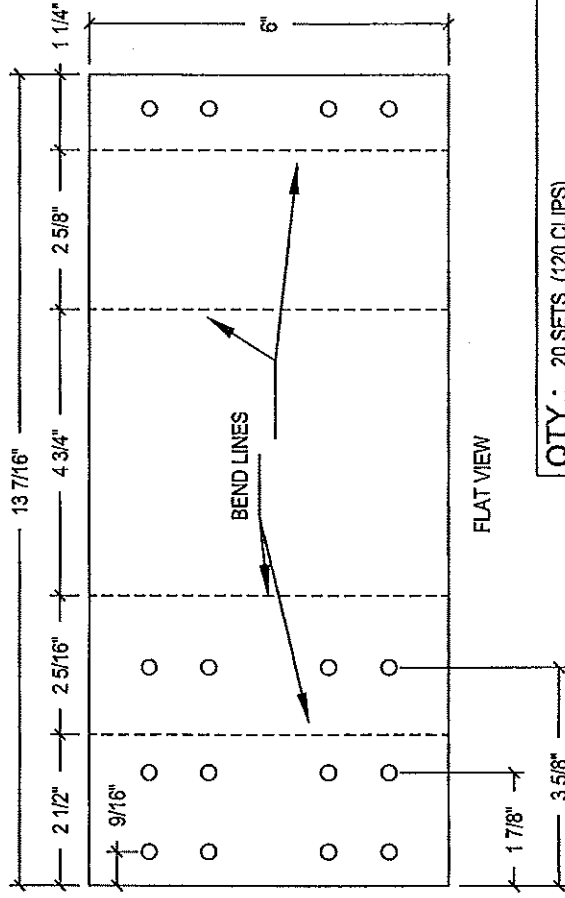
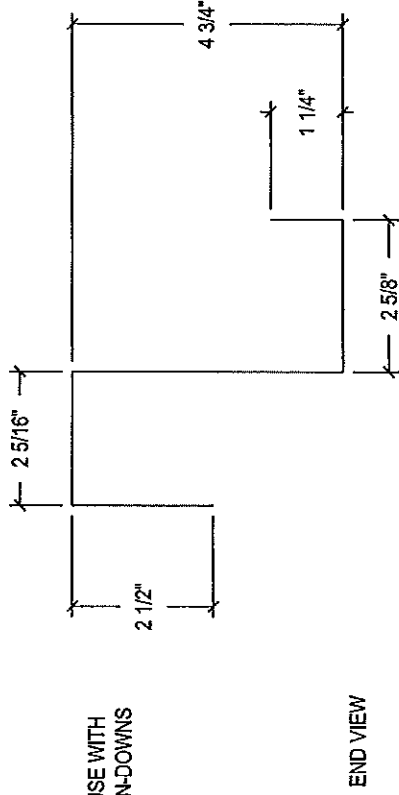
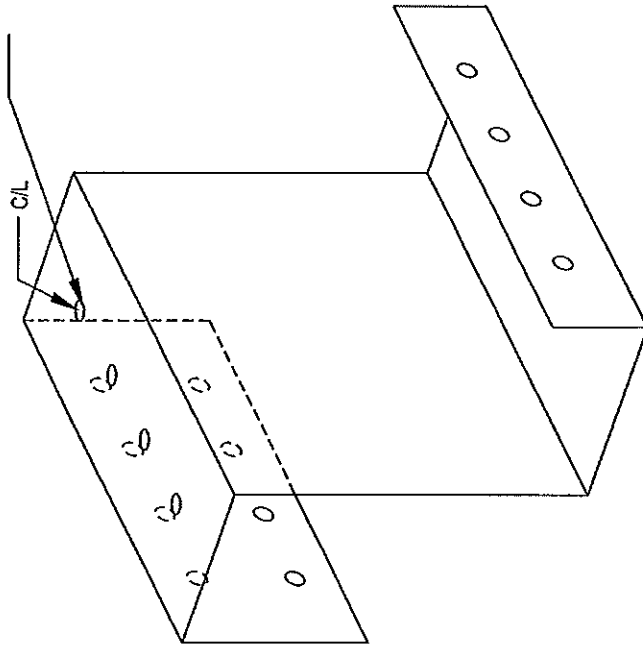

**LENNOX UNIT CLIPS**  
**MODEL# L/T/K/S-SERIES/LGH-LCH 024-360**

NOTE: 1 SET = 6 UNIT CLIPS  
 ATTACH VIA (8) 3/4"X14X1 3/4" TEK SCREWS

**CURBS PLUS, INC.**  
 1200 Carline Rd. 205 Metcalf Rd.  
 Rossville, GA 30741 El Dorado, KS 67042  
 Phone: (706) 858-1188 / FAX (706) 866-2339  
 website: www.curbs-plus.com

**LENNOX PART# X6523**

QTY.: 20 SETS (120 CLIPS)
PROJECT NAME:
CITY, STATE:
CUSTOMER:
JOB NUMBER:
TAG:

31803 ODU

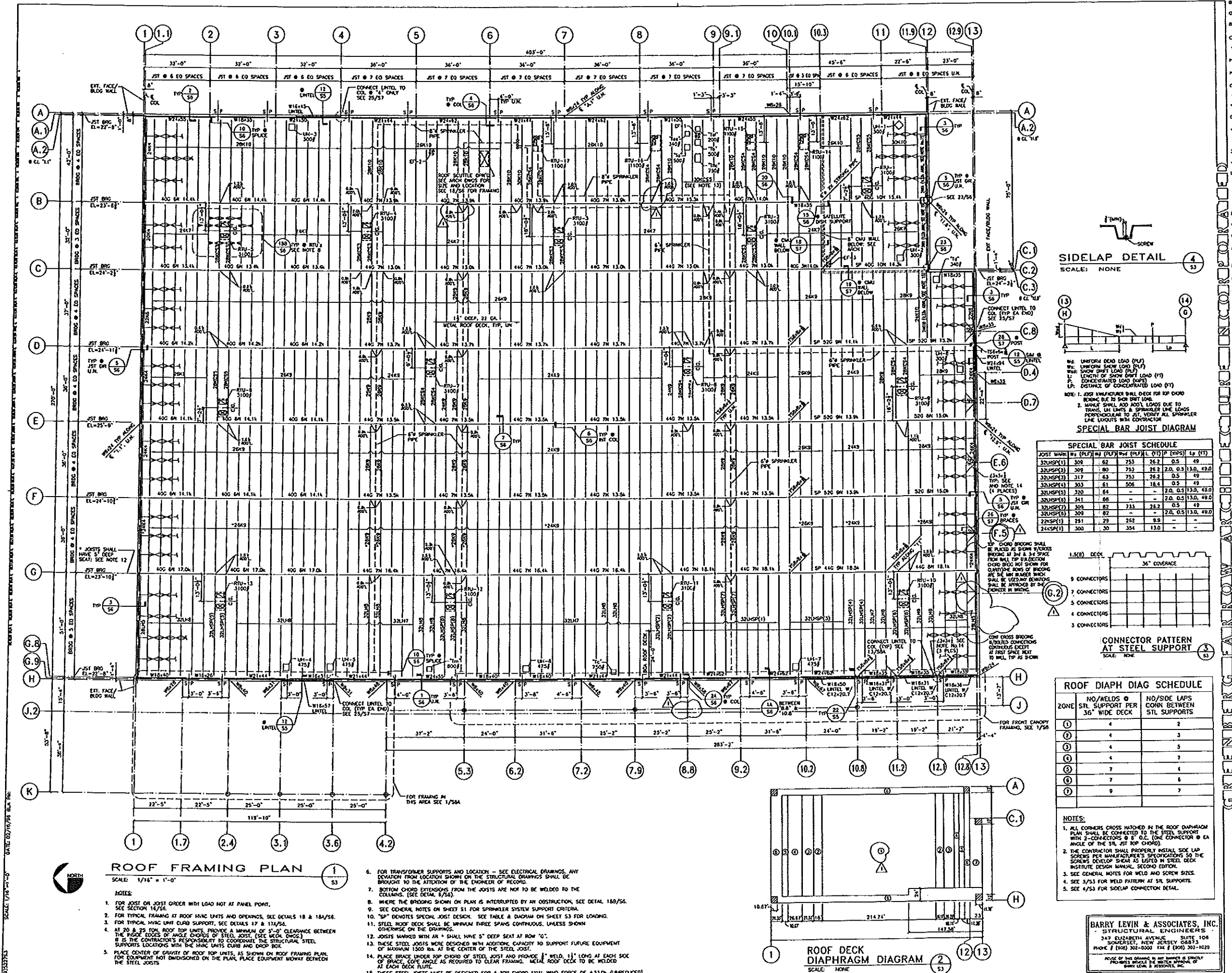

**ROOF FRAMING PLAN**

SCALE: 1/16" = 1'-0"

- NOTES:**
- FOR JOIST OR JOIST ORDER WITH LOAD NOT AT PANEL POINT, SEE SECTION 16/56.
  - FOR TYPICAL FRAMING AT ROOF HVAC UNITS AND OPENINGS, SEE DETAILS 18 & 18A/56.
  - FOR TYPICAL HVAC UNIT CURB SUPPORT, SEE DETAILS 17 & 17A/56.
  - AT 20 & 25 TON ROOF TOP UNITS, PROVIDE A MINIMUM OF 5'-0" CLEARANCE BETWEEN THE WIDE EDGES OF ANGLE CHORDS OF STEEL JOIST. (SEE MECH. NOTES) IT IS THE CONTRACTOR'S RESPONSIBILITY TO COORDINATE THE STRUCTURAL STEEL SUPPORTS LOCATIONS WITH THE HVAC UNITS CURB AND DROP BOX.
  - PLACE CENTER OF GRAVITY OF ROOF TOP UNITS, AS SHOWN ON ROOF FRAMING PLAN, TOP EQUIPMENT NOT DIMENSIONED ON THE PLAN, PLACE EQUIPMENT MOUNTY BETWEEN THE STEEL JOISTS.

- FOR TRANSFORMER SUPPORTS AND LOCATION - SEE ELECTRICAL DRAWINGS, ANY DEVIATION FROM LOCATION SHOWN ON THE STRUCTURAL DRAWINGS SHALL BE BROUGHT TO THE ATTENTION OF THE ENGINEER OF RECORD.
- BOTTOM CHORD EXTENSIONS FROM THE JOISTS ARE NOT TO BE WELDED TO THE COLUMNS. (SEE DETAIL 6/56).
- WHERE THE BRACING SHOWN ON PLAN IS INTERRUPTED BY AN OBSTRUCTION, SEE DETAIL 18D/56.
- SEE GENERAL NOTES ON SHEET #1 FOR SPRINKLER SYSTEM CRITERIA.
- "SP" DENOTES SPECIAL JOIST DESIGN. SEE TABLE & DIAGRAM ON SHEET #3 FOR LOADING.
- STEEL ROOF DECK SHALL BE MINIMUM THREE CONTINUOUS, UNLESS SHOWN OTHERWISE ON THE DRAWINGS.
- JOISTS MARKED WITH AN "X" SHALL HAVE 5" DEEP SEAT AT ROW "G".
- THESE STEEL JOISTS WERE DESIGNED WITH ADDITIONAL CAPACITY TO SUPPORT FUTURE EQUIPMENT OF MAXIMUM 1200 LB. AT THE CENTER OF THE STEEL JOIST.
- PLACE BRACE UNDER TOP CHORD OF STEEL JOIST AND PROVIDE 1" WELD, 11" LONG AT EACH SIDE OF BRACE. CORNER ANGLE AS REQUIRED TO CLEAR FRAMING. METAL ROOF DECK TO BE WELDED AT EACH DECK FLUTE.
- THESE STEEL JOISTS MUST BE DESIGNED FOR A TOP CHORD AXIAL WIND FORCE OF 4.33KA (UNREduced).

**SIDELAP DETAIL**

SCALE: NONE

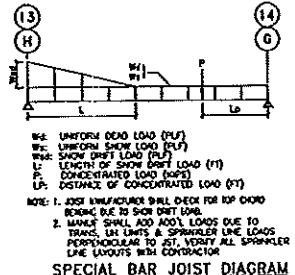

**SPECIAL BAR JOIST DIAGRAM**

JOIST MARK	Wt (LBS)	Wt (KIP)	Wt (KIP)	Wt (KIP)	Wt (KIP)	Wt (KIP)	Wt (KIP)
32LHSP(1)	309	82	753	26.2	0.5	49	
32LHSP(2)	309	80	753	26.2	2.0	0.9	13.0, 43.0
32LHSP(3)	317	63	753	26.2	0.5	49	
32LHSP(4)	303	61	506	18.6	0.5	49	
32LHSP(5)	320	64	-	-	2.0	0.5	13.0, 43.0
32LHSP(6)	341	88	-	-	2.0	0.5	13.0, 43.0
32LHSP(7)	309	82	753	26.2	0.5	49	
32LHSP(8)	309	82	-	-	2.0	0.5	13.0, 43.0
24KSP(1)	281	22	252	8.9	-	-	-
24KSP(2)	300	30	354	13.0	-	-	-

**CONNECTOR PATTERN AT STEEL SUPPORT**

SCALE: NONE

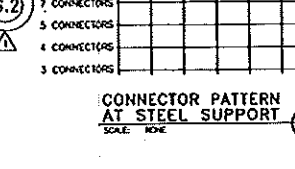

**ROOF DIAPHRAGM SCHEDULE**

ZONE	NO/WELDS @ STL SUPPORT PER 36" WIDE DECK	NO/SIDE LAPS CONN BETWEEN STL SUPPORTS
①	4	2
②	4	3
③	4	5
④	4	7
⑤	7	4
⑥	7	6
⑦	9	7

- NOTES:**
- ALL CORNERS CROSS HATCHED IN THE ROOF DIAPHRAGM PLAN SHALL BE CONNECTED TO THE STEEL SUPPORT WITH 2-CORNECTORS @ 6" O.C. (ONE CONNECTOR @ EA ANGLE OF THE STL JOIST TOP CHORD).
  - THE CONNECTOR SHALL PROVIDE THE SAME SIDE LAP STRENGTH PER MANUFACTURER'S SPECIFICATIONS SO THE SCREWS DEVELOP SHEAR AS LISTED IN STEEL DECK MANUFACTURER'S DESIGN MANUAL, SECOND EDITION.
  - SEE GENERAL NOTES FOR WELD AND SCREW SIZES.
  - SEE 4/53 FOR WELD PATTERN AT STL SUPPORTS.
  - SEE 4/53 FOR SIDELAP CONNECTION DETAIL.

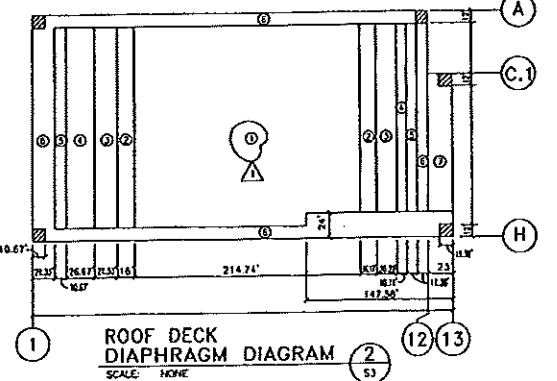

**ROOF DECK DIAPHRAGM DIAGRAM**

SCALE: NONE

9 2 7 PEACHTREE ROAD N.E. ATLANTA, GEORGIA 30319 TEL 404.237.5297 FAX 404.237.0898  
 HOME DEPOT U.S.A., INC. STORE NUMBER 2401  
 PORTLAND RIVERSIDE STREET & WARREN AVENUE PORTLAND, MAINE  
 HOME DEPOT STANDARDS BY SEMESTER/YEAR/REGION ASSNE

PROJECT NUMBER: 15445.00  
 SHEET SET DATE: 02/29/94  
 PROJECT MANAGER: B. OLES  
 QUALITY CONTROL: B. OLES  
 SHEET TITLE: ROOF FRAMING PLAN  
 SHEET NUMBER: 53