

City of Portland, Maine - Building or Use Permit Application
 389 Congress Street, 04101 Tel: (207) 874-8703, Fax: (207) 874-8716

PERMIT ISSUED

Permit No: 04-0586	Issue Date: MAY 12 2004	CBL: 308 B052001
-----------------------	----------------------------	---------------------

Location of Construction: 210 Lane Ave	Owner Name: Hoglund James M &	Owner Address: 210 Lane Ave	Phone: 797-9516
Business Name:	Contractor Name: self	Contractor Address: Portland	Phone:
Lessee/Buyer's Name	Phone:	Permit Type: Additions - Dwellings	Zone: R3

Past Use: Single Family	Proposed Use: Single Family w/ deck after the fact	Permit Fee: \$180.00	Cost of Work: \$1,000.00	CEO District: 5
14' x 31' deck & stairs after the fact		FIRE DEPT: <input type="checkbox"/> Approved <input type="checkbox"/> Denied	INSPECTION: Use Group: R3 Type: SB A 1999 Signature: JMB 5/12/04	
		Signature: PEDESTRIAN ACTIVITIES DISTRICT (P.A.D.)		
		Action: <input type="checkbox"/> Approved <input type="checkbox"/> Approved w/Conditions <input type="checkbox"/> Denied		
		Signature: Date:		

Permit Taken By: jmb	Date Applied For: 05/12/2004	Zoning Approval	
-------------------------	---------------------------------	------------------------	--

1. This permit application does not preclude the Applicant(s) from meeting applicable State and Federal Rules. 2. Building permits do not include plumbing, septic or electrical work. 3. Building permits are void if work is not started within six (6) months of the date of issuance. False information may invalidate a building permit and stop all work..	Special Zone or Reviews <input type="checkbox"/> Shoreland <input type="checkbox"/> Wetland <i>Approved</i> <input type="checkbox"/> Flood Zone <i>orig permit</i> <input type="checkbox"/> Subdivision <i># 01-0359</i> <input type="checkbox"/> Site Plan Maj <input type="checkbox"/> Minor <input type="checkbox"/> MM <input type="checkbox"/> Date: <i>JMB 5/12/04</i>	Zoning Appeal <input type="checkbox"/> Variance <input type="checkbox"/> Miscellaneous <input type="checkbox"/> Conditional Use <input type="checkbox"/> Interpretation <input type="checkbox"/> Approved <input type="checkbox"/> Denied Date:	Historic Preservation <input checked="" type="checkbox"/> Not in District or Landmark <input type="checkbox"/> Does Not Require Review <input type="checkbox"/> Requires Review <input type="checkbox"/> Approved <input type="checkbox"/> Approved w/Conditions <input type="checkbox"/> Denied Date: <i>JMB</i>
--	--	---	---

CERTIFICATION

I hereby certify that I am the owner of record of the named property, or that the proposed work is authorized by the owner of record and that I have been authorized by the owner to make this application as his authorized agent and I agree to conform to all applicable laws of this jurisdiction. In addition, if a permit for work described in the application is issued, I certify that the code official's authorized representative shall have the authority to enter all areas covered by such permit at any reasonable hour to enforce the provision of the code(s) applicable to such permit.

SIGNATURE OF APPLICANT	ADDRESS	DATE	PHONE
RESPONSIBLE PERSON IN CHARGE OF WORK, TITLE		DATE	PHONE

All Purpose Building Permit Application

If you or the property owner owes real estate or personal property taxes or user charges on any property within the City, payment arrangements must be made before permits of any kind are accepted.

Location/Address of Construction: <u>210 LAKE HILL</u>		
Total Square Footage of Proposed Structure <u>390 SF</u>		Square Footage of Lot 7800 SF <u>8100 SF</u>
Tax Assessor's Chart, Block & Lot Chart# <u>303</u> Block# <u>B52</u> Lot# _____		Owner: <u>JAMES HUGLUND</u> Telephone: <u>779516</u>
Lessee/Buyer's Name (If Applicable)	Applicant name, address & telephone: <u>JAMES HUGLUND</u> <u>210 LAKE HILL</u> <u>PORTLAND, ME 04103</u>	Cost Of Work: \$ <u>1000 -</u> Fee: \$ <u>30.00</u>
Current use: <u>Single Family Home</u>		<u>\$50.00</u> ^{SWD} _{late fee}
If the location is currently vacant, what was prior use: <u>NOT VACANT</u>		<u>180.00</u>
Approximately how long has it been vacant: <u>N/A</u>		
Proposed use: Project description: <u>12' x 31' Deck w/stairs</u>		
Contractor's name, address & telephone: Who should we contact when the permit is ready: <u>JAMES HUGLUND</u> Mailing address: <u>210 LAKE HILL</u> <u>PORTLAND, ME 04103</u>		
We will contact you by phone when the permit is ready. You must come in and pick up the permit and review the requirements before starting any work, with a Plan Reviewer. A stop work order will be issued and a \$100.00 fee if any work starts before the permit is picked up, PHONE:		

IF THE REQUIRED INFORMATION IS NOT INCLUDED IN THE SUBMISSIONS THE PERMIT WILL BE AUTOMATICALLY DENIED AT THE DISCRETION OF THE BUILDING/PLANNING DEPARTMENT, WE MAY REQUIRE ADDITIONAL INFORMATION IN ORDER TO APPROVE THIS PERMIT.

I hereby certify that I am the Owner of record of the named property, or that the owner of record authorizes the proposed work and that I have been authorized by the owner to make this application as his/her authorized agent. I agree to conform to all applicable laws of this jurisdiction. In addition, if a permit for work described in this application is issued, I certify that the Code Official's authorized representative shall have the authority to enter all areas covered by this permit at any reasonable hour to enforce the provisions of the codes applicable to this permit.

Signature of applicant: 	Date: <u>4.11.04</u>
---	----------------------

**This is NOT a permit, you may not commence ANY work until the permit is issued.
If you are in a Historic District you may be subject to additional permitting and fees with the Planning Department on the 4th floor of City Hall**

This page contains a detailed description of the Parcel ID you selected. Press the **New Search** button at the bottom of the screen to submit a new query.

Current Owner Information

Card Number 1 of 1
 Parcel ID 308 B052001
 Location 210 LANE AVE
 Land Use SINGLE FAMILY

Owner Address HOGLUND JAMES M 8 RENE A HOGLUND JTS
 210 LANE AVE
 PORTLAND ME 04103

Book/Page 19425/256
 Legal 308-B-52
 LANE AVE 208-212
 8100 SF

5/12
~~2/10~~ 10-10-15
 Deck After The fact
 04-0586
 R3

Valuation Information

Land	Building	Total
\$31,190	\$128,520	\$159,710

Property Information

Year Built 2001	Style Garrison	Story Height 2	Sq. Ft. 1974	Total Acres 0.186
Bedrooms 3	Full Baths 2	Half Baths 1	Total Rooms 6	Attic None
				Basement Full

Outbuildings

Type	Quantity	Year Built	Size	Grade	Condition
------	----------	------------	------	-------	-----------

Sales Information

Date	Type	Price	Book/Page
05/01/2003	LAND + ELDING	\$245,000	19425-256
04/09/2001	LAND + ELDING		16177-245
10/19/2000	LAND		15794-126

Picture and Sketch

Picture Sketch

Click here to view Tax Roll Information.

Any information concerning tax payments should be directed to the Treasury office at 874-8490 or e-mailed.

New Search!

Handwritten calculations and notes:

- 560
- 360
- 560
- 1480
- 1410
- 1890
- 225 SF
- 372
- 38
- Deck
- OK
- 8100
- 425%
- 2025 SF



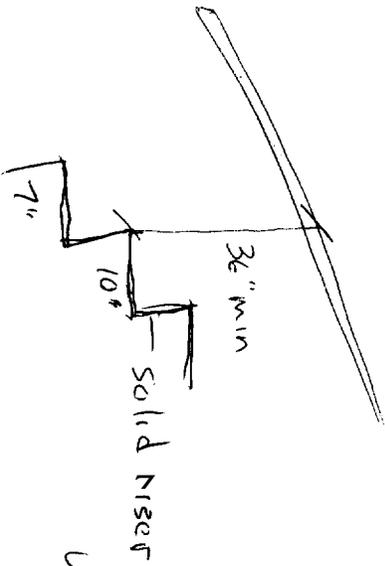

w/ gaspable H-Rail

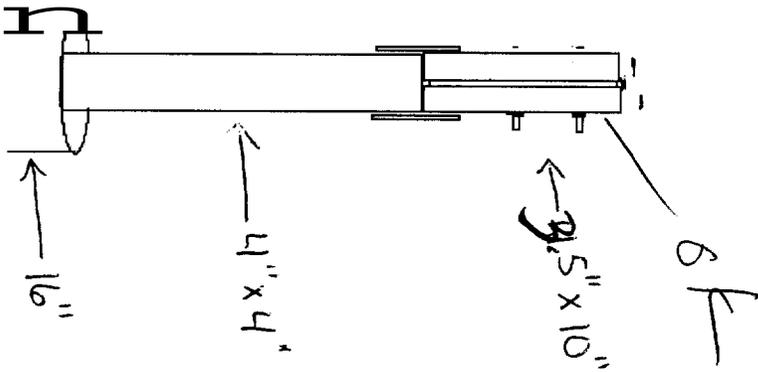
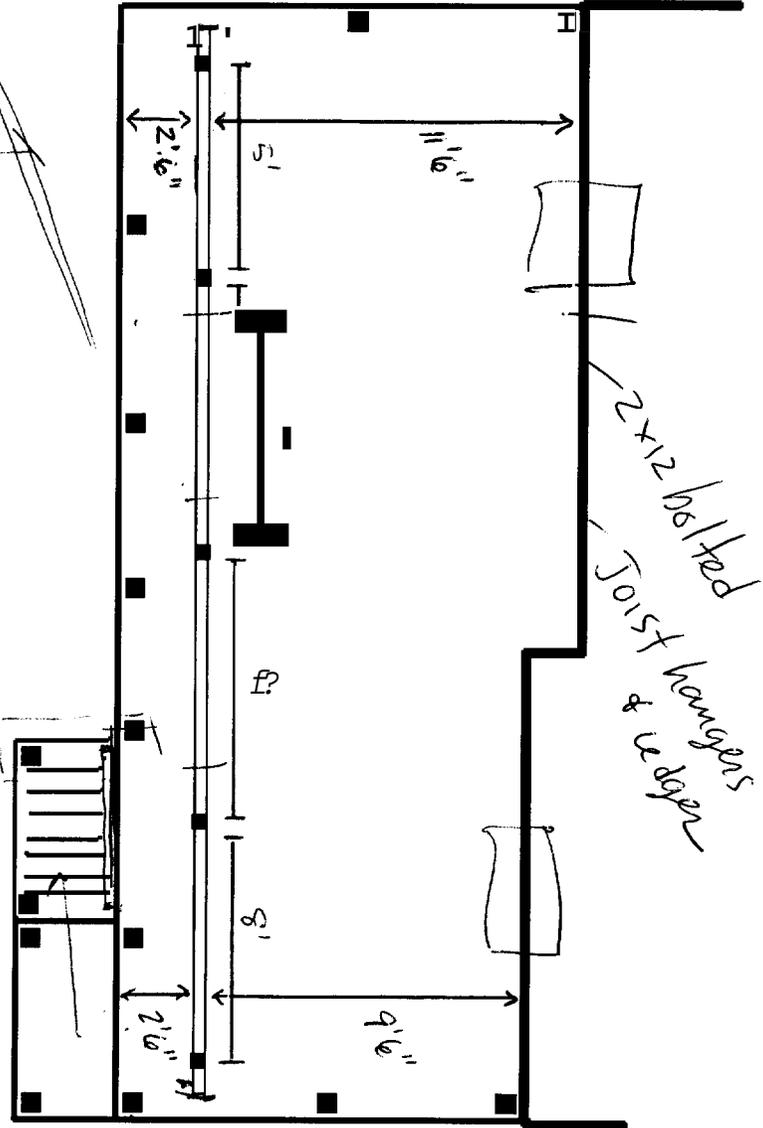

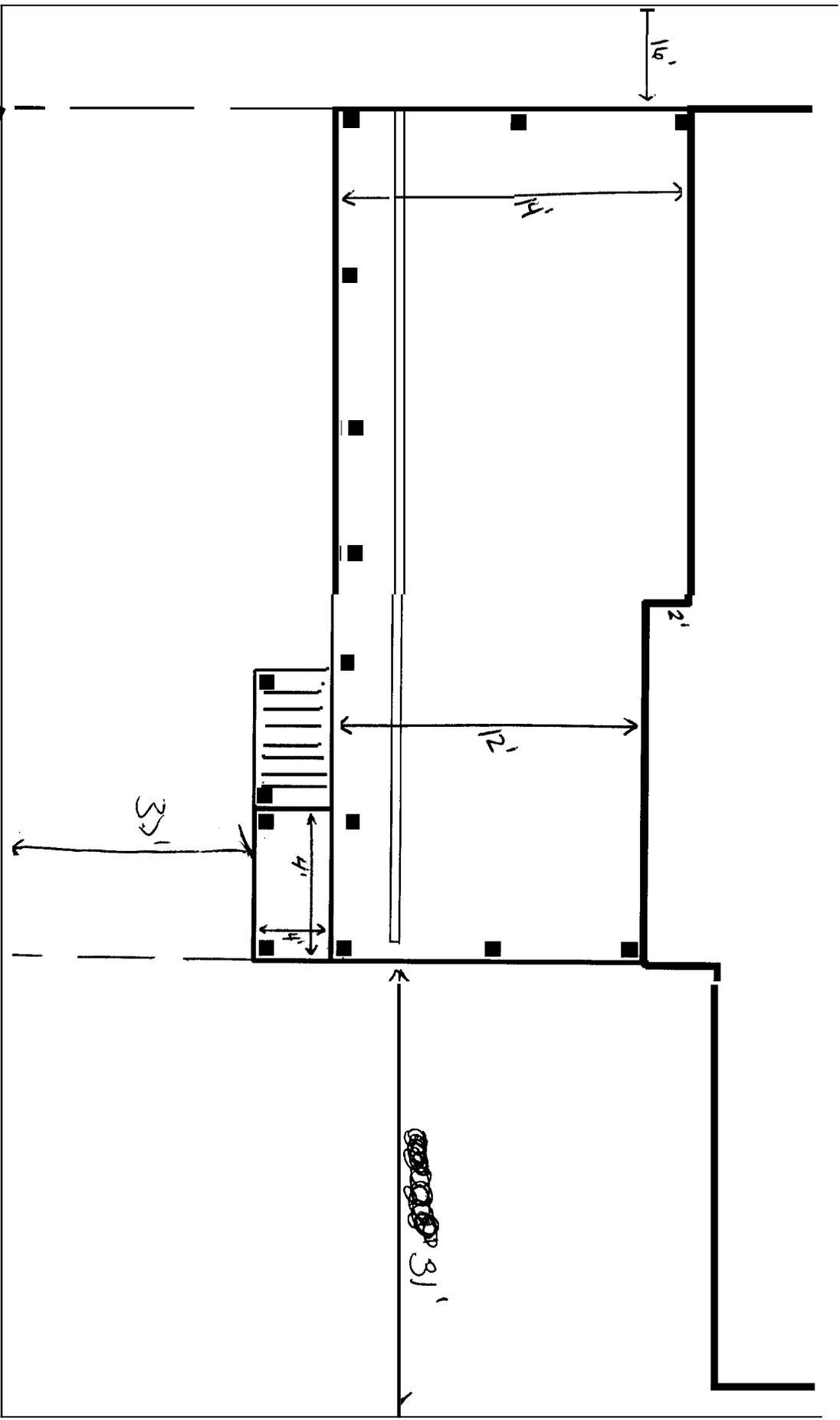

R3 Zone
 Room 25' Reg 37' shown
 Side 8' Reg 16' & 31' shown

31'

~~31'~~

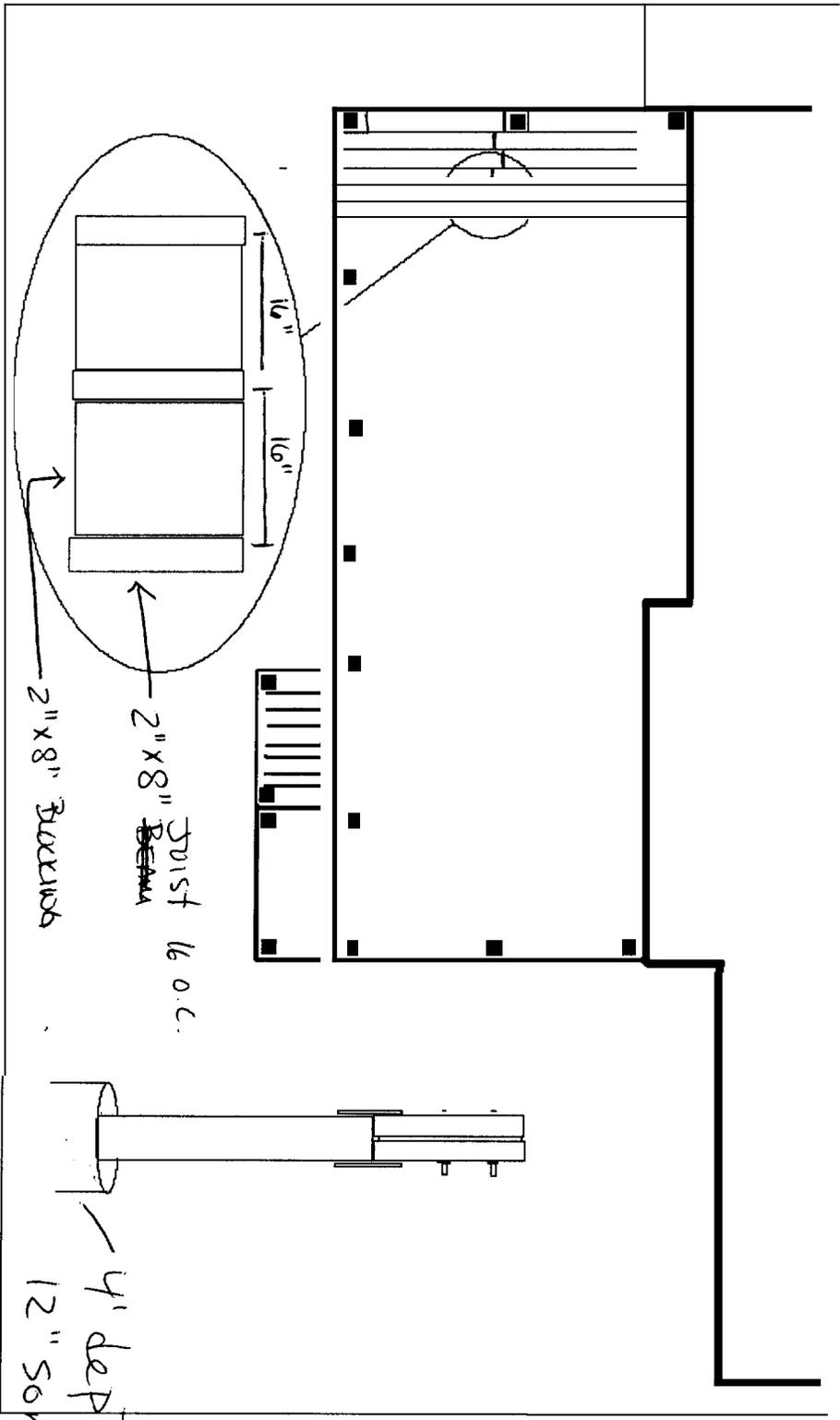

2" x 8" Joist
 2" x 8" Backstab
 16" 16"

4' depth
 12" Sona
 4x4 extends down
 into sona

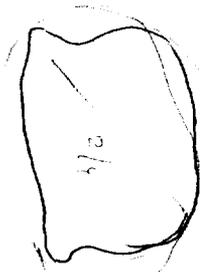

6" max

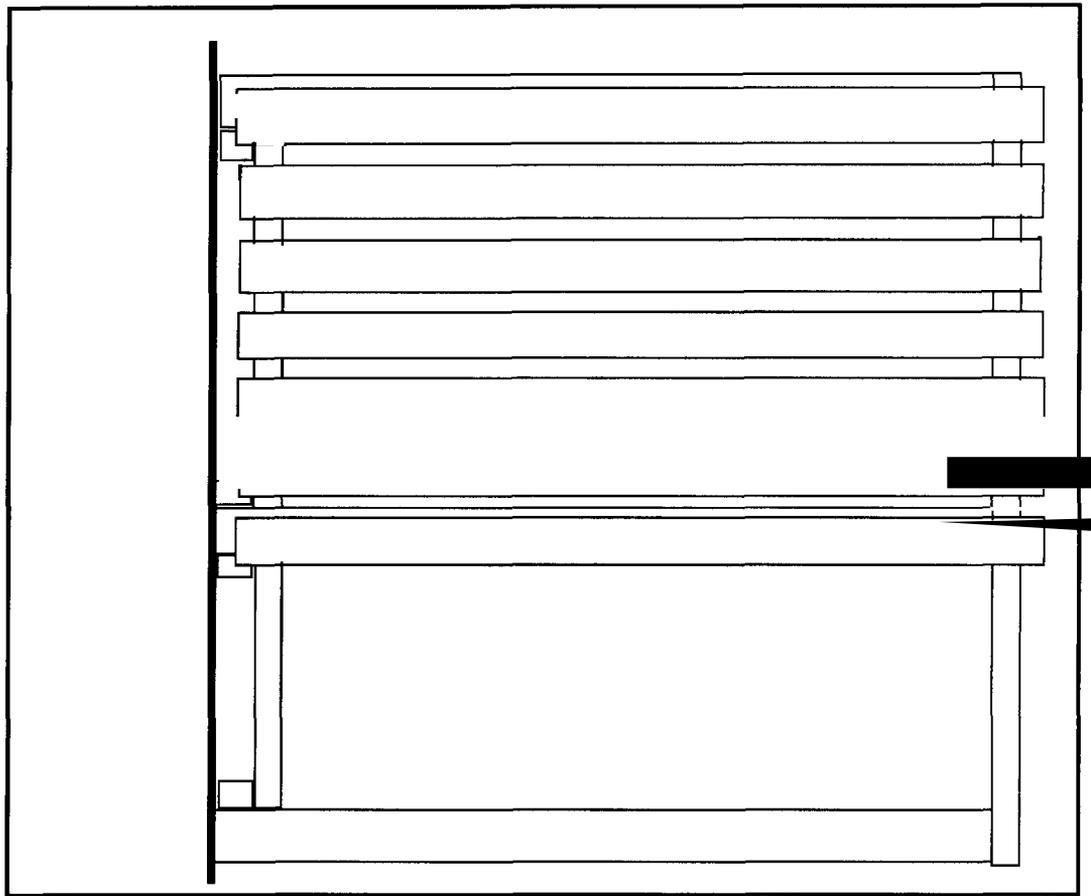
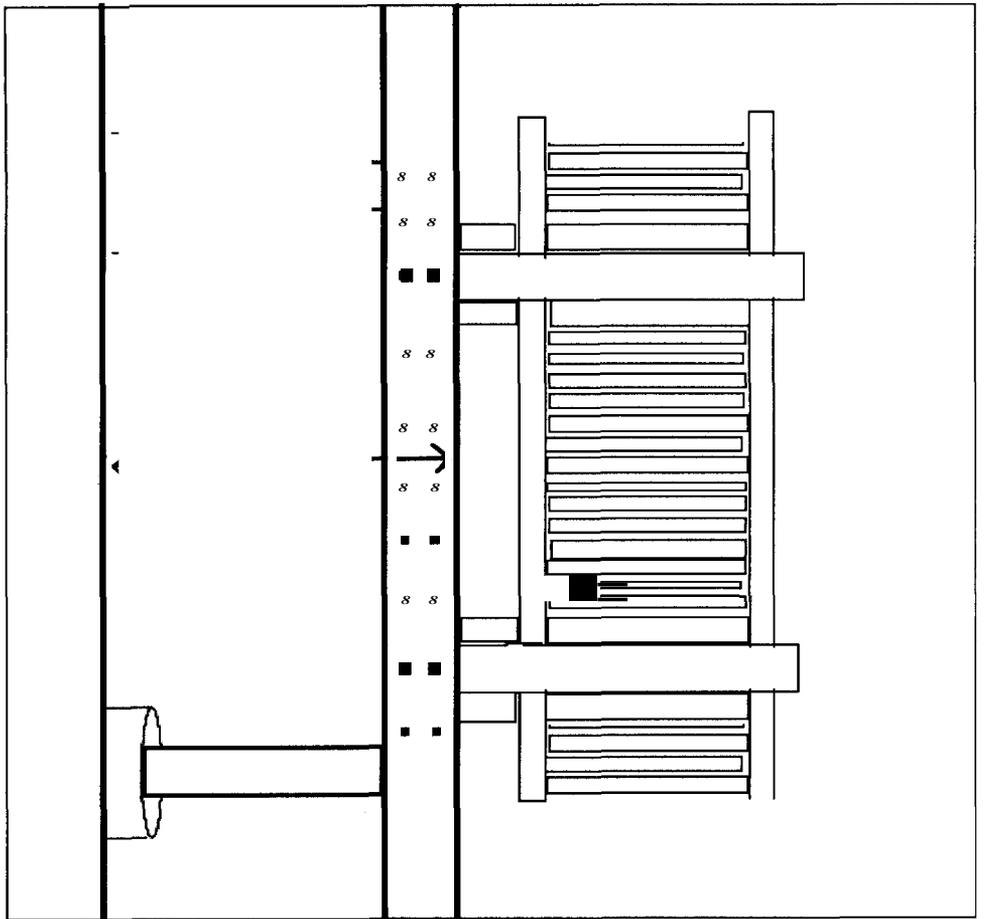

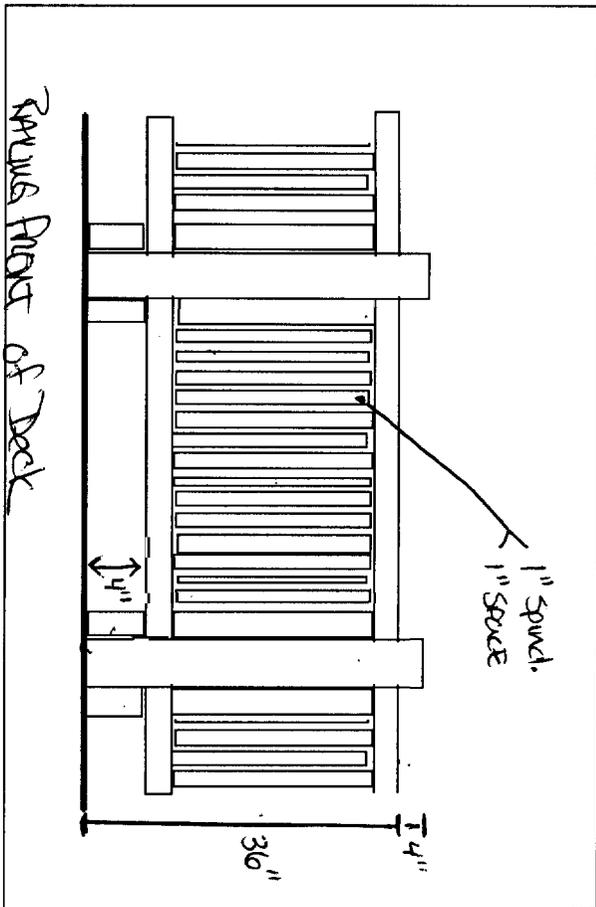

FRONT OF DECK

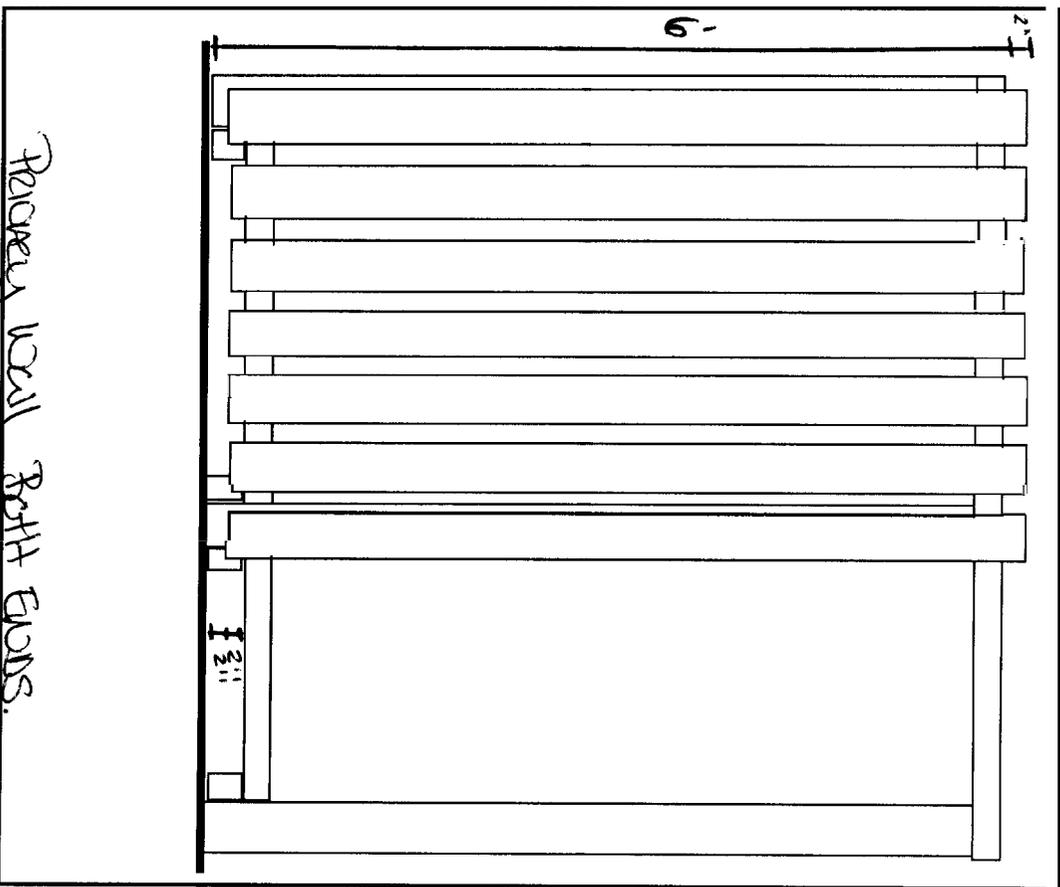

FRONT OF DECK

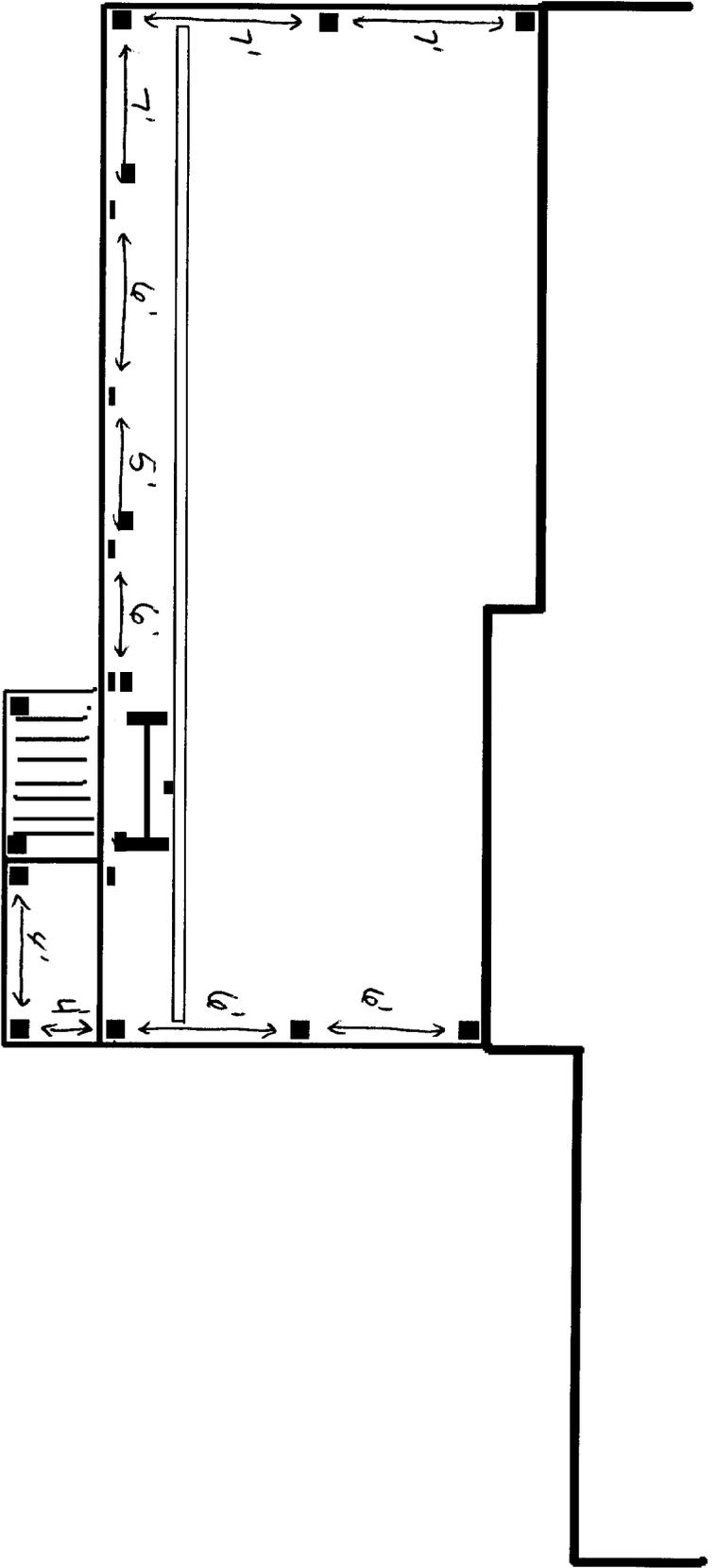

This data is provided by the Assessor's Office and is current as of **May 3, 2004**

CBL 308 B052001 **CARD** 1 of 1
Owner Name 1 HOGGLUND JAMES M &
Name 2 RENE A HOGGLUND JTS
Mailing Address 210 LANE AVE
City, State, Zip PORTLAND ME 04103

Property Address 210 LANE AVE
Property Type RESIDENTIAL
Description 308-B-52
 LANE AVE 208-212
 8100 SF

- [New Complaint](#)
- [Scheduling](#)
- [View Complaint](#)
- [Close](#)
- [View Inspection](#)
- [Print](#)
- [View Application](#)
- [View Permit](#)

[View Outstanding Taxes](#)

Fees Date	Business	Fees Type	Fees Amount	Date Paid	Paid Amount
		late fee	\$100.00	5/3/04	\$0.00
		stop work order removal	\$100.00		\$0.00
		stop work order	\$100.00		\$0.00

BUILDING PERMIT INSPECTION PROCEDURES

Please call 874-8703 or 874-8693 to schedule your inspections as agreed upon

Permits expire in 6 months, if the project is not started or ceases for 6 months.

The Owner or their designee is required to notify the inspections office for the following inspections and provide adequate notice. Notice must be called in 48-72 hours in advance in order to schedule an inspection:

By initializing at each inspection time, you are agreeing that you understand the inspection procedure and additional fees from a "Stop Work Order" and "Stop Work Order Release" will be incurred if the procedure is not followed as stated below.

JB ~~Pre-construction Meeting: Must be scheduled with your inspection team upon receipt of this permit. Jay Reynolds, Development Review Coordinator at 874-8632 must also be contacted at this time, before any site work begins on any project other than single family additions or alterations.~~

- | | | |
|-------------------------------------|---------------------------------------|--|
| <input type="checkbox"/> | Footing/Building Location Inspection; | Prior to pouring concrete |
| <input type="checkbox"/> | Re-Bar Schedule Inspection: | Prior to pouring concrete |
| <input type="checkbox"/> | Foundation Inspection: | Prior to placing ANY backfill |
| <input type="checkbox"/> | Framing/Rough Plumbing/Electrical: | Prior to any insulating or drywalling |
| <input checked="" type="checkbox"/> | Final/Certificate of Occupancy: | Prior to any occupancy of the structure or use. NOTE: There is a \$75.00 fee per inspection at this point. |

after the fact

Certificate of Occupancy is not required for certain projects. Your inspector can advise you if your project requires a Certificate of Occupancy. All projects DO require a final inspection

If any of the inspections do not occur, the project cannot go on to the next phase, REGARDLESS OF THE NOTICE OR CIRCUMSTANCES.

CERIFICATE OF OCCUPANICES MUST BE ISSUED AND PAID FOR, BEFORE THE SPACE MAY BE OCCUPIED

Signature of Applicant/Designee

Date

Signature of Inspections Official

Date

CBL: 308-B-52

Building Permit #: 04-0586

BUILDING PERMIT INSPECTION PROCEDURES

Please call 874-8703 or 874-8693 to schedule your inspections as agreed upon

Permits expire in 6 months, if the project is not started or ceases for 6 months.

The Owner or their designee is required to notify the inspections office for the following inspections and provide adequate notice. Notice must be called in 48-72 hours in advance in order to schedule an inspection:

By initializing at each inspection time, you are agreeing that you understand the inspection procedure and additional fees from a "Stop Work Order" and "Stop Work Order Release" will be incurred if the procedure is not followed as stated below.

JB ~~Pre-construction Meeting: Must be scheduled with your inspection team upon receipt of this permit. Jay Reynolds, Development Review Coordinator at 874-8632 must also be contacted at this time, before any site work begins on any project other than single family additions or alterations.~~

- | | | |
|-------------------------------------|---------------------------------------|--|
| <input type="checkbox"/> | Footing/Building Location Inspection; | Prior to pouring concrete |
| <input type="checkbox"/> | Re-Bar Schedule Inspection: | Prior to pouring concrete |
| <input type="checkbox"/> | Foundation Inspection: | Prior to placing ANY backfill |
| <input type="checkbox"/> | Framing/Rough Plumbing/Electrical: | Prior to any insulating or drywalling |
| <input checked="" type="checkbox"/> | Final/Certificate of Occupancy: | Prior to any occupancy of the structure or use. NOTE: There is a \$75.00 fee per inspection at this point. |

after fact

Certificate of Occupancy is not required for certain projects. Your inspector can advise you if your project requires a Certificate of Occupancy. **All** projects DO require a final inspection

If any of the inspections do not occur, the project cannot go on to the next phase, REGARDLESS OF THE NOTICE OR CIRCUMSTANCES.

CERIFICATE OF OCCUPANICES MUST BE ISSUED AND PAID FOR, BEFORE THE SPACE MAY BE OCCUPIED

Signature of Applicant/Designee

Date

Signature of Inspections Official

Date

CBL: 308-B-52

Building Permit #: 04-0586

DISPLAY THIS CARD ON PRINCIPAL FRONTAGE OF WORK

CITY OF PORTLAND

BUILDING INSPECTION

PERMIT

PERMIT ISSUED

MAY 12 2004

Permit Number: 040586

CITY OF PORTLAND

Please Read Application And Notes, If Any, Attached

This is to certify that Honlund James M &/self has permission to 14' x 31' deck & stairs after the fact AT 210 Lane Ave 308 B052001

provided that the person or persons, firm or corporation accepting this permit shall comply with all of the provisions of the Statutes of Maine and of the ordinances of the City of Portland regulating the construction, maintenance and use of buildings and structures, and of the application on file in this department.

Apply to Public Works for street line and grade if nature of work requires such information.

Notification of inspection must be given and written permission procured before this building or part thereof is altered or closed-in. HOUR NOTICE IS REQUIRED.

A certificate of occupancy must be procured by owner before this building or part thereof is occupied.

OTHER REQUIRED APPROVALS

Fire Dept. Health Dept. Appeal Board Other Department Name

Jeanie Bouke 5/12/04 Director - Building & Inspection Services

PENALTY FOR REMOVING THIS CARD