

OUTDOOR

DURAWORX™

GOES THE DISTANCE™

8 ft. x 6 ft.

Storage Shed

Abri de rangement

Coberlizo de almacenamiento

Please thoroughly read the owners manual
before beginning assembly.
All stated sizes are nominal.

----- English
Veuillez lire attentivement le manuel de l'utilisateur avant
de commencer le montage de la remise.
----- Français

----- Español
Por favor, lea con atención el manual del
usuario antes de comenzar el montaje.
Todos los tamaños indicados son nominales.

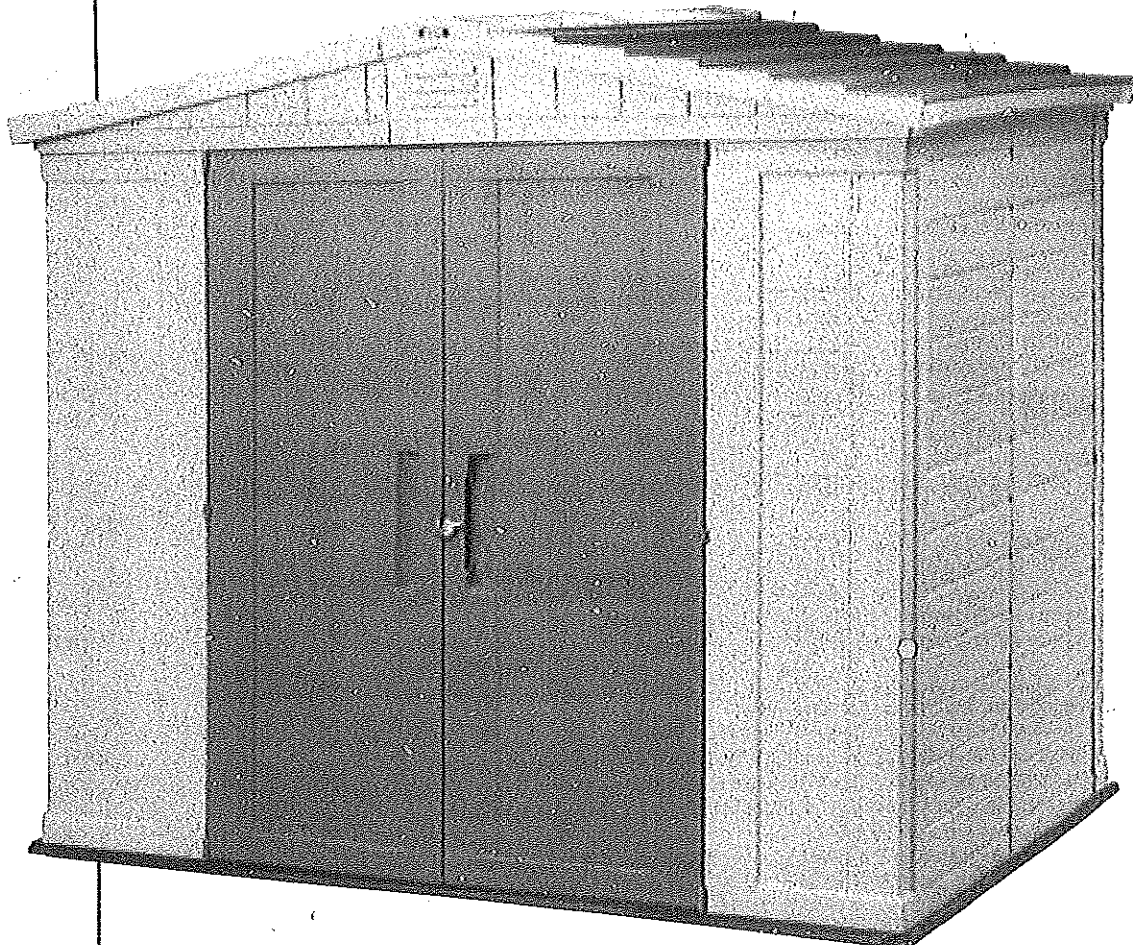

- Tools and accessories in illustration not included
- Les outils et les accessoires figurant sur l'illustration ne sont pas inclus
- No se incluyen las herramientas ni los accesorios de la ilustración

Assembly parts • Pièces à assembler • Montagetelle • Piezas de ensamble • Montagestücken • Parti da montare • Peças de montagem

• Packaging may contain some additional small parts to be kept for use as spare parts. • L'emballage peut contenir des petites pièces supplémentaires à conserver comme pièce de rechange. • Die Verpackung kann eventuell zusätzliche Kleinteile enthalten, die in Zukunft als Ersatzteile verwendet werden können. • El embalaje puede contener algunas partes pequeñas adicionales que se deben guardar para ser usadas como repuestos. • A embalagem poderá conter algumas peças pequenas adicionais que servem para ser usadas como peças sobresselentes. • De verpakking kan enkele extra kleine onderdelen houden die als reserveonderdelen kunnen worden gebruikt. • La confezione potrebbe contenere piccole parti supplementari da utilizzare come parti di ricambio.

- Floor Panels
- Pannøaux du sol
- Bodenelemente
- Paneles del piso
- Vloerpanelen
- Pannelli del pavimento
- Painéis do piso

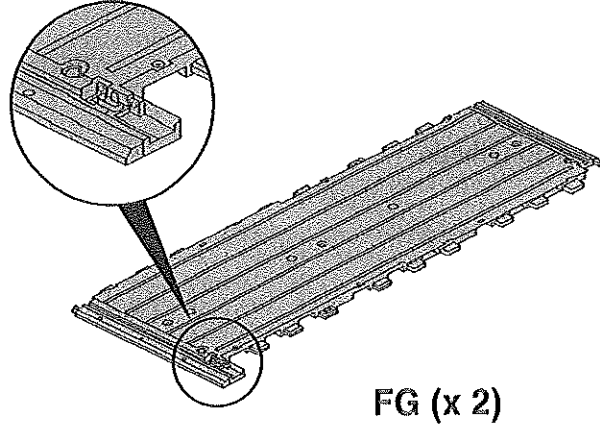
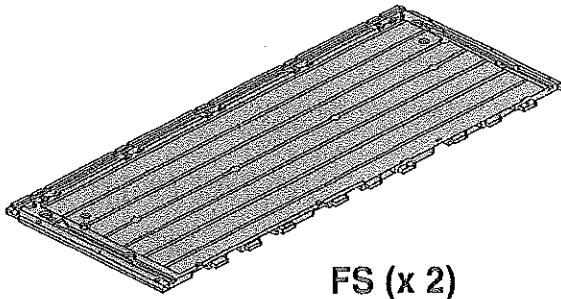

- Wall parts
- Pièces du contour
- Wandelemente
- Partes de las paredes
- Muuronderdelen
- Parti della parete
- Painéis laterais

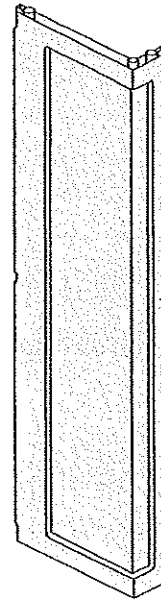
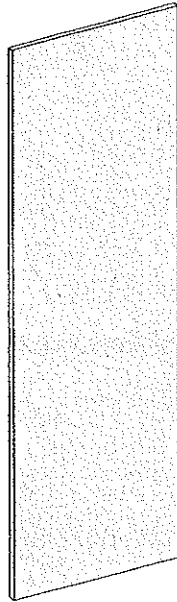
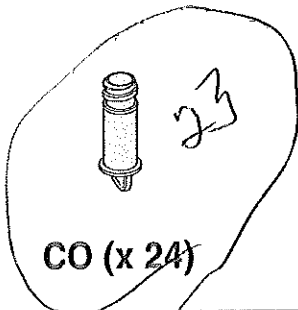

Screws • Vis • Schrauben • Tornillos • Schroeven • Viti • Parafusos

SC4(x 22)

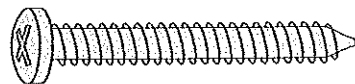

SC1(x 12)

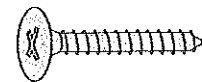

SC12(x 4)

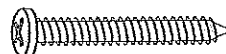

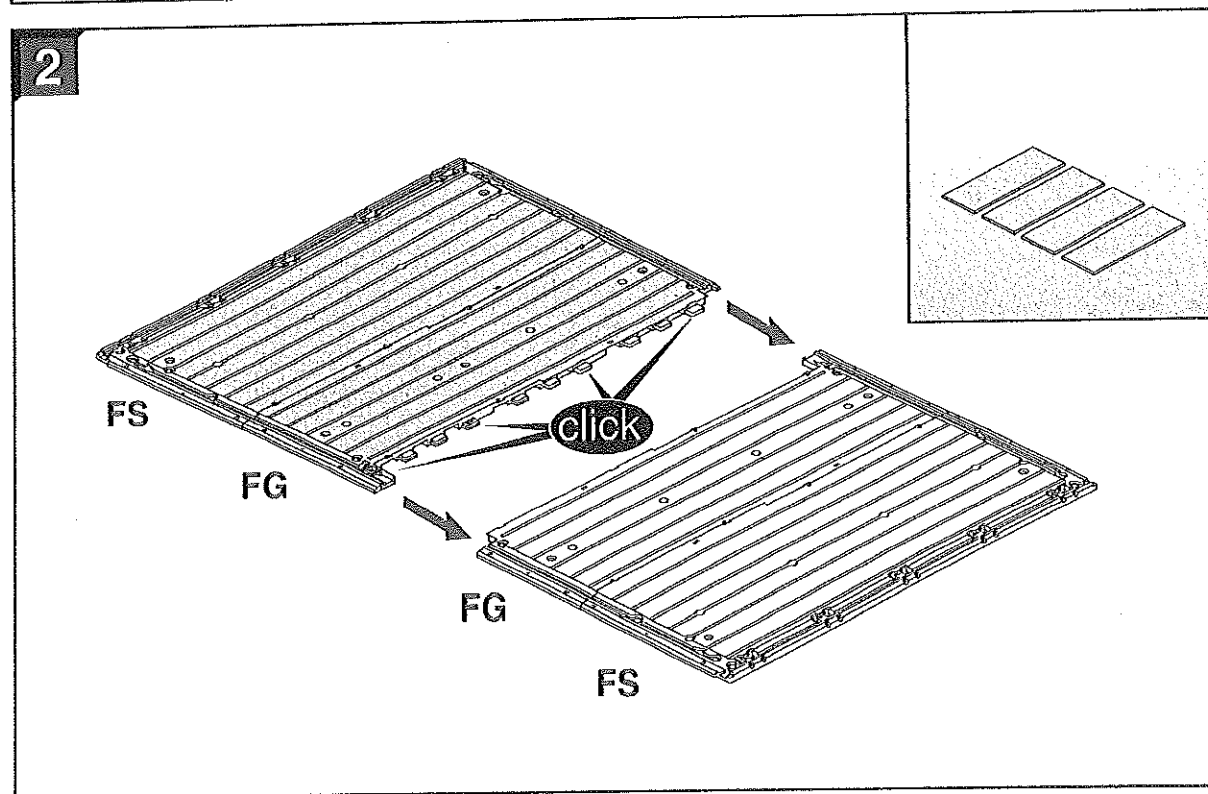
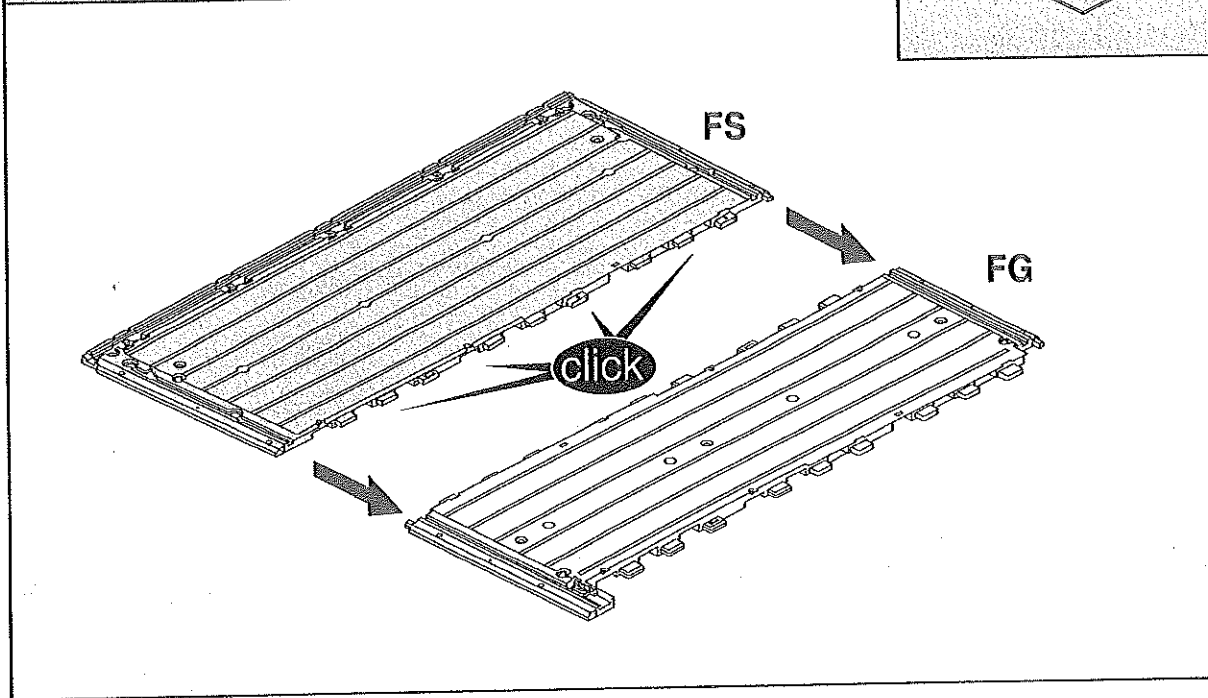
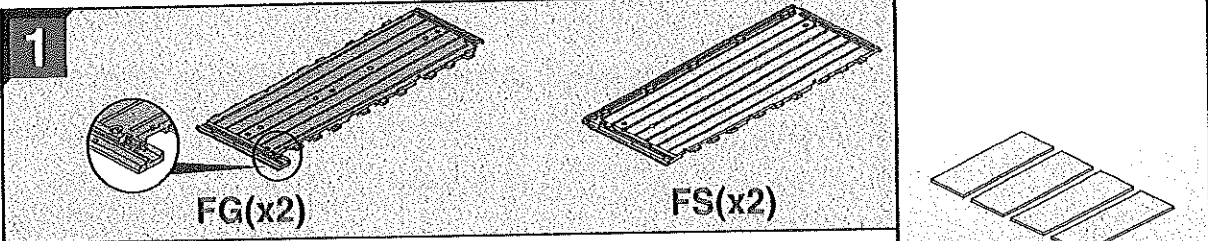

3

SC1(x12)

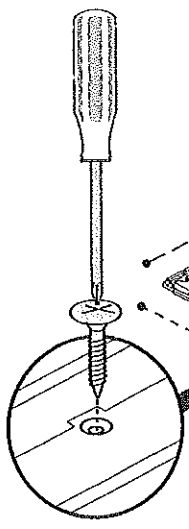
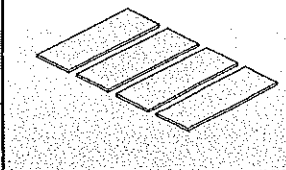
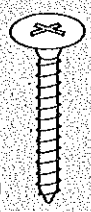

69" / 175cm

98" / 249cm

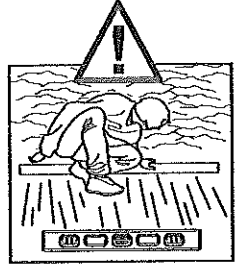
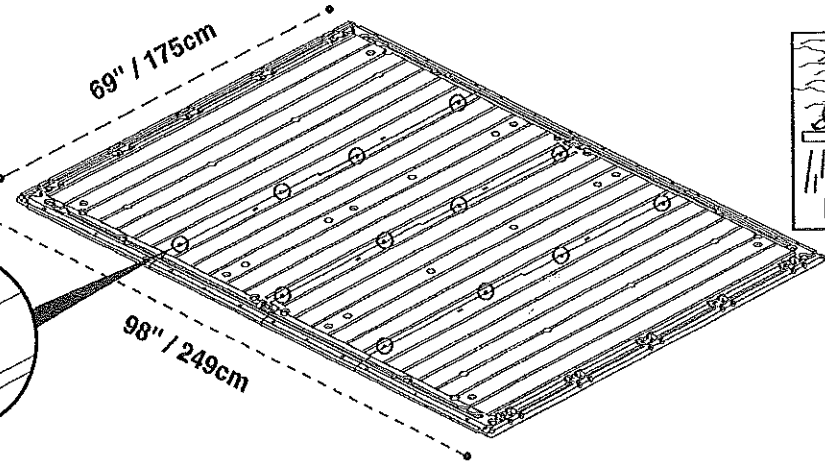

SHELL ASSEMBLY • MONTAGE DE LA STRUCTURE • GERÜSTMONTAGE • MONTAGE DEL ARMAZON • MONTAGGIO DELLA STRUTTURA
GERÄTESAMENSTELLUNG • MONTAGEM DA ESTRUTURA

4

CO(x3)

O(x1)

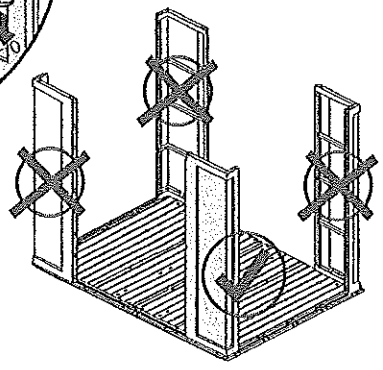
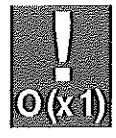
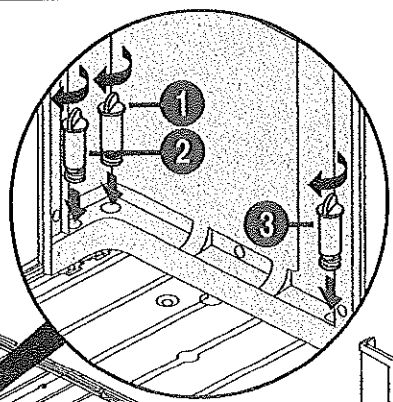
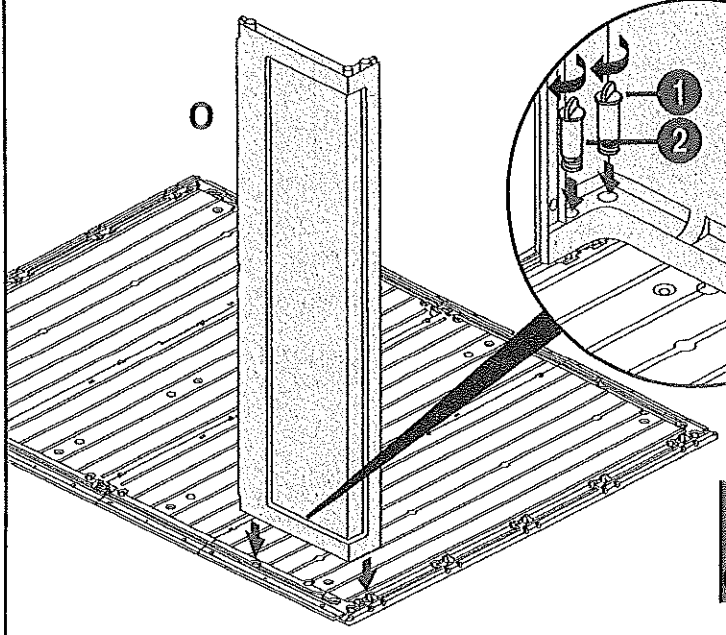
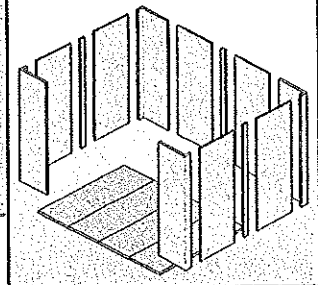

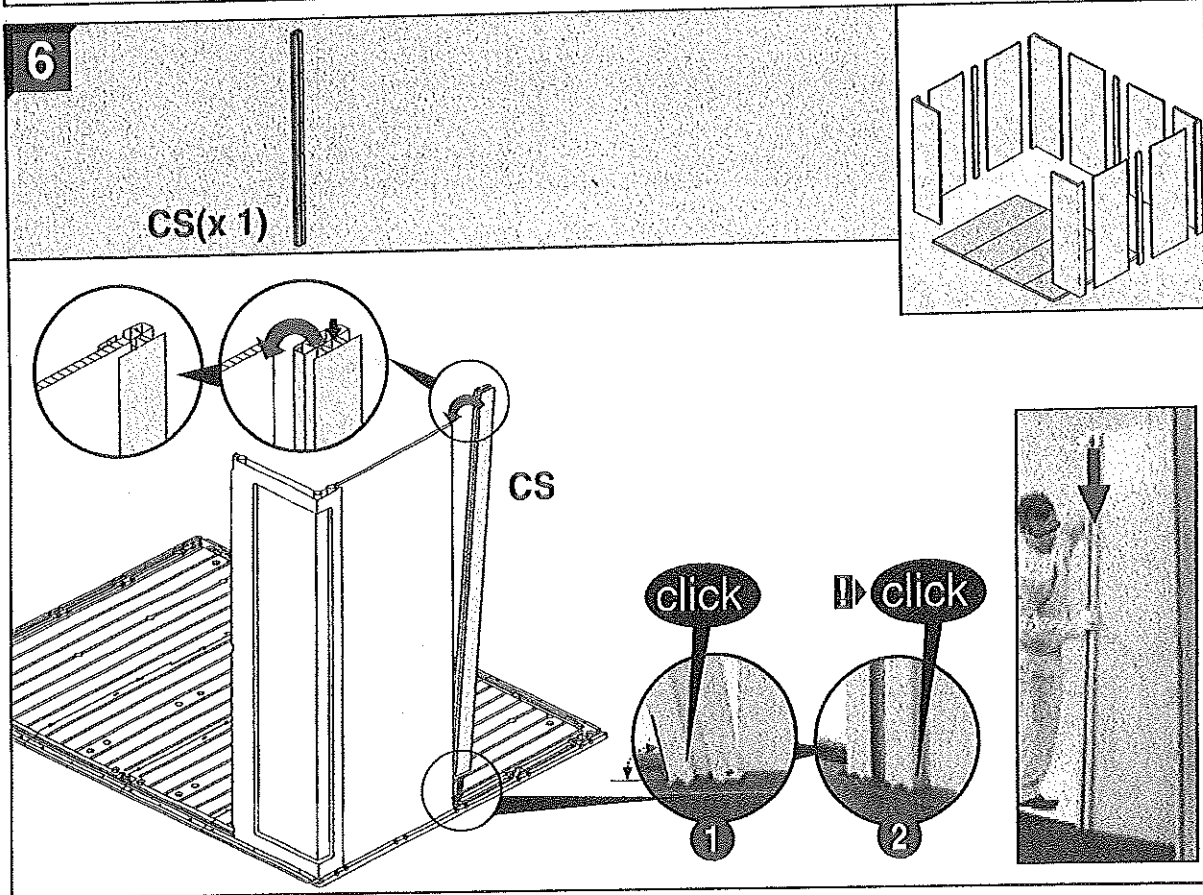
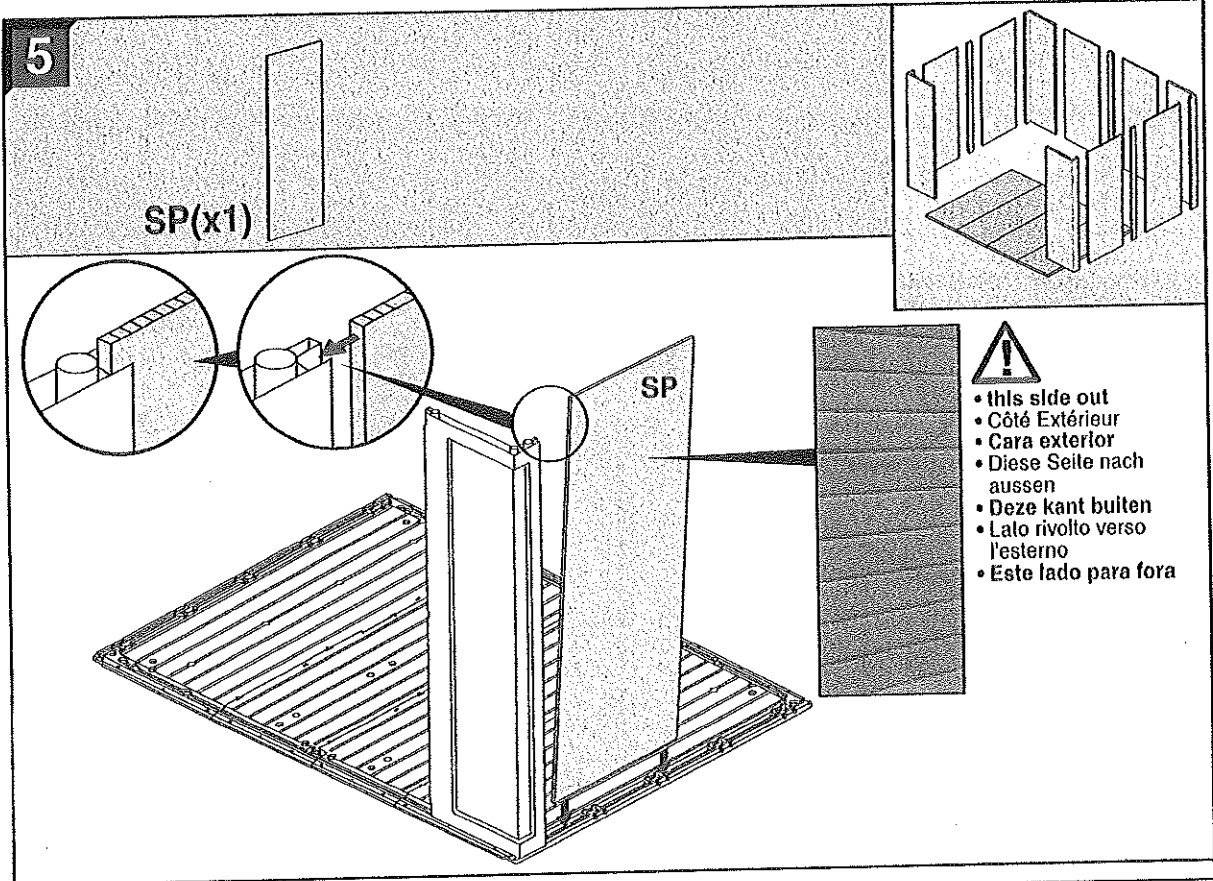

9

CO(x2)

TDL (x 1)

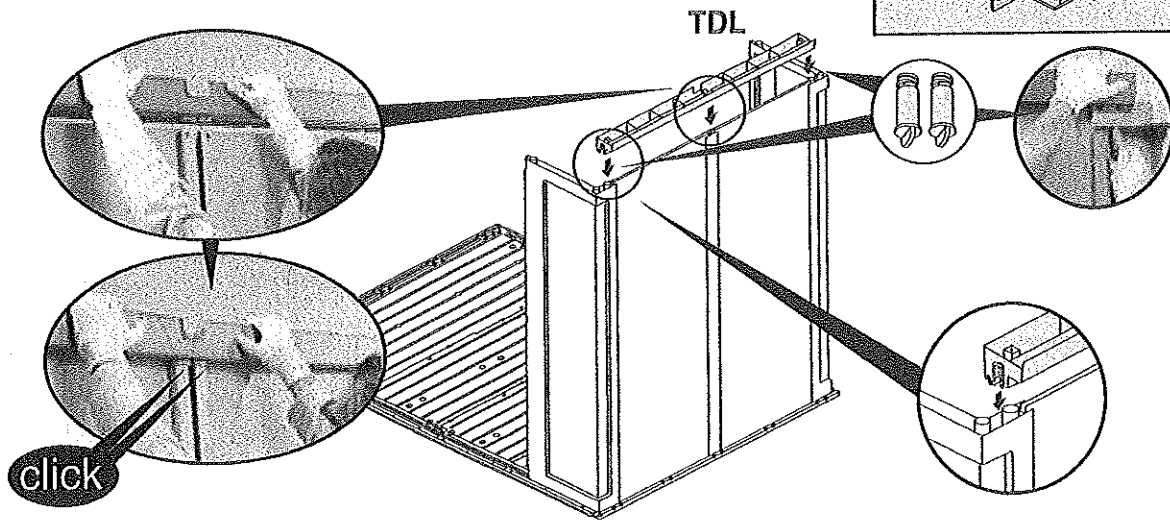
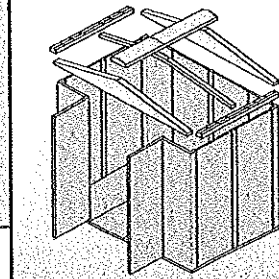

10

CO(x3)

CS(x1)

SP(x 2)

O(x1)

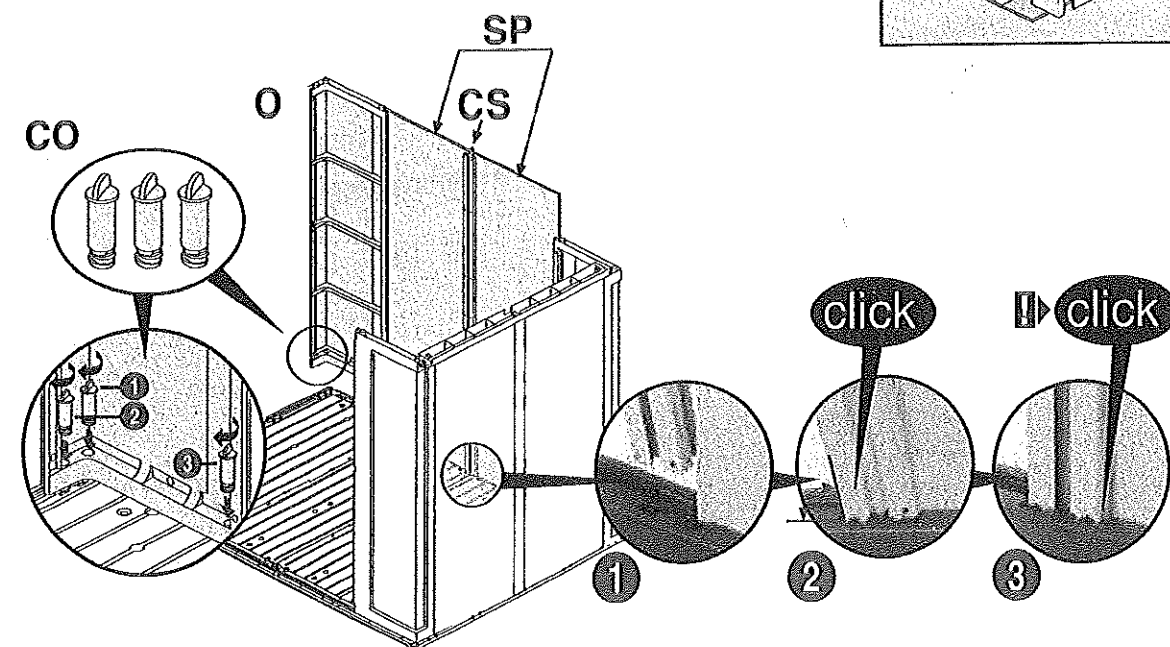
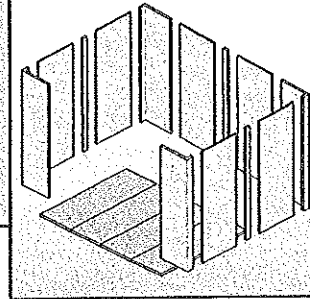

11

CO(x3)

CS(x1)

SP(x2)

O(x1)

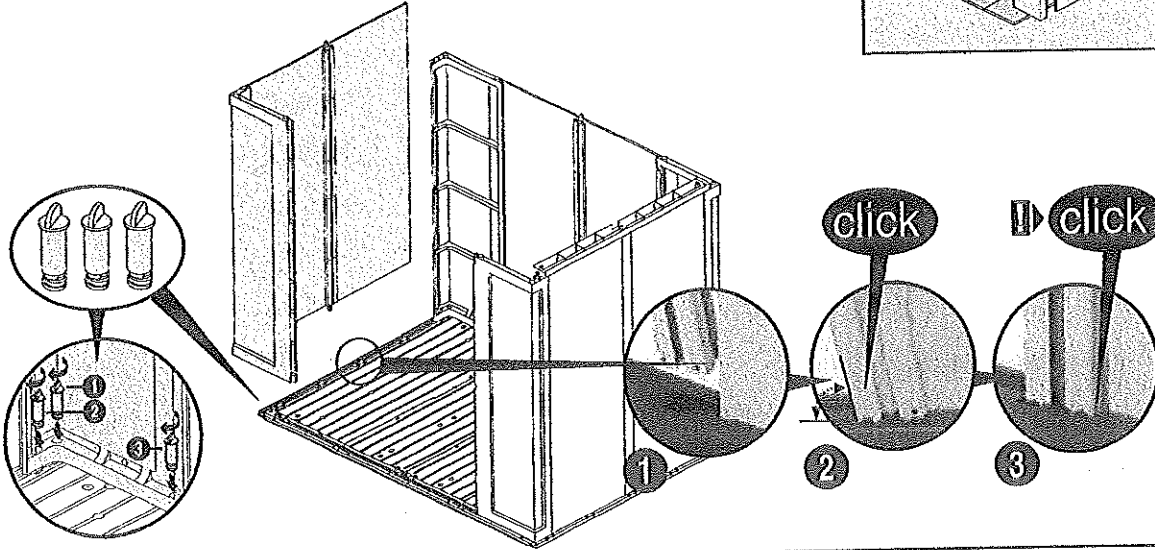
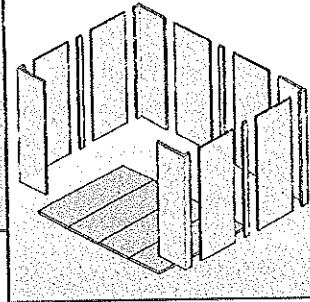

12

CO(x2)

TDL(x1)

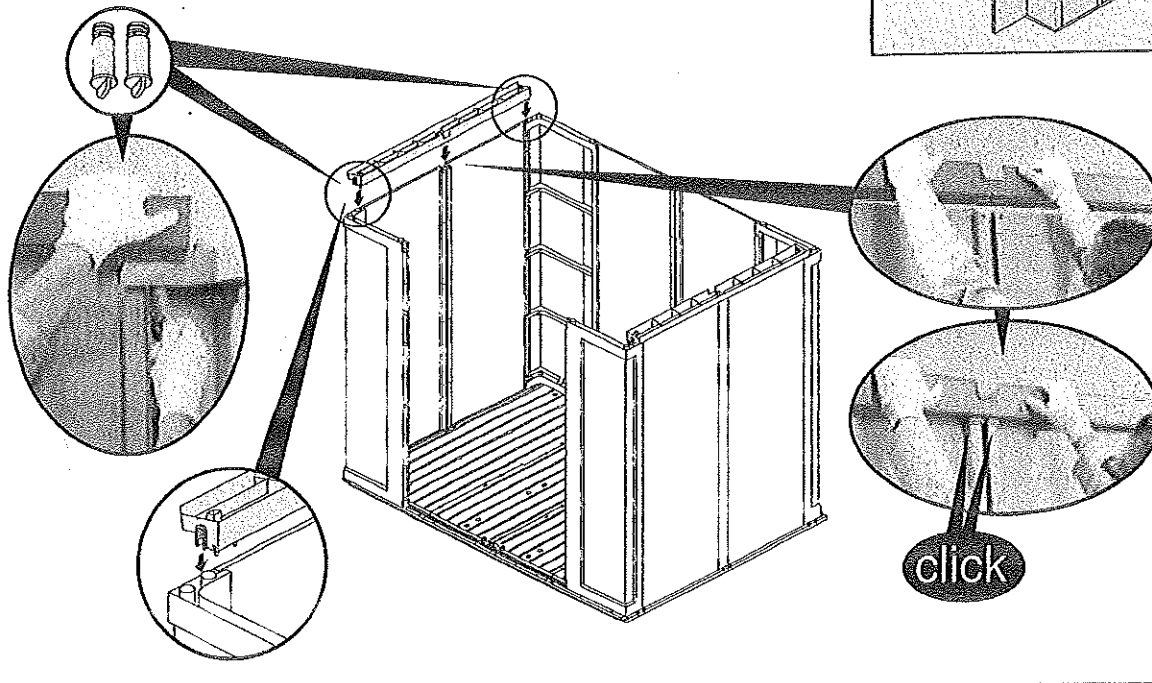
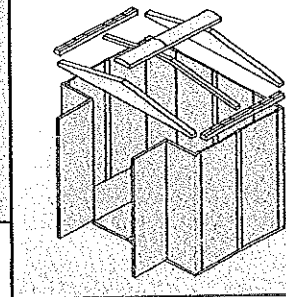

13



DB(x2)



DX(x2)



HG(x4)

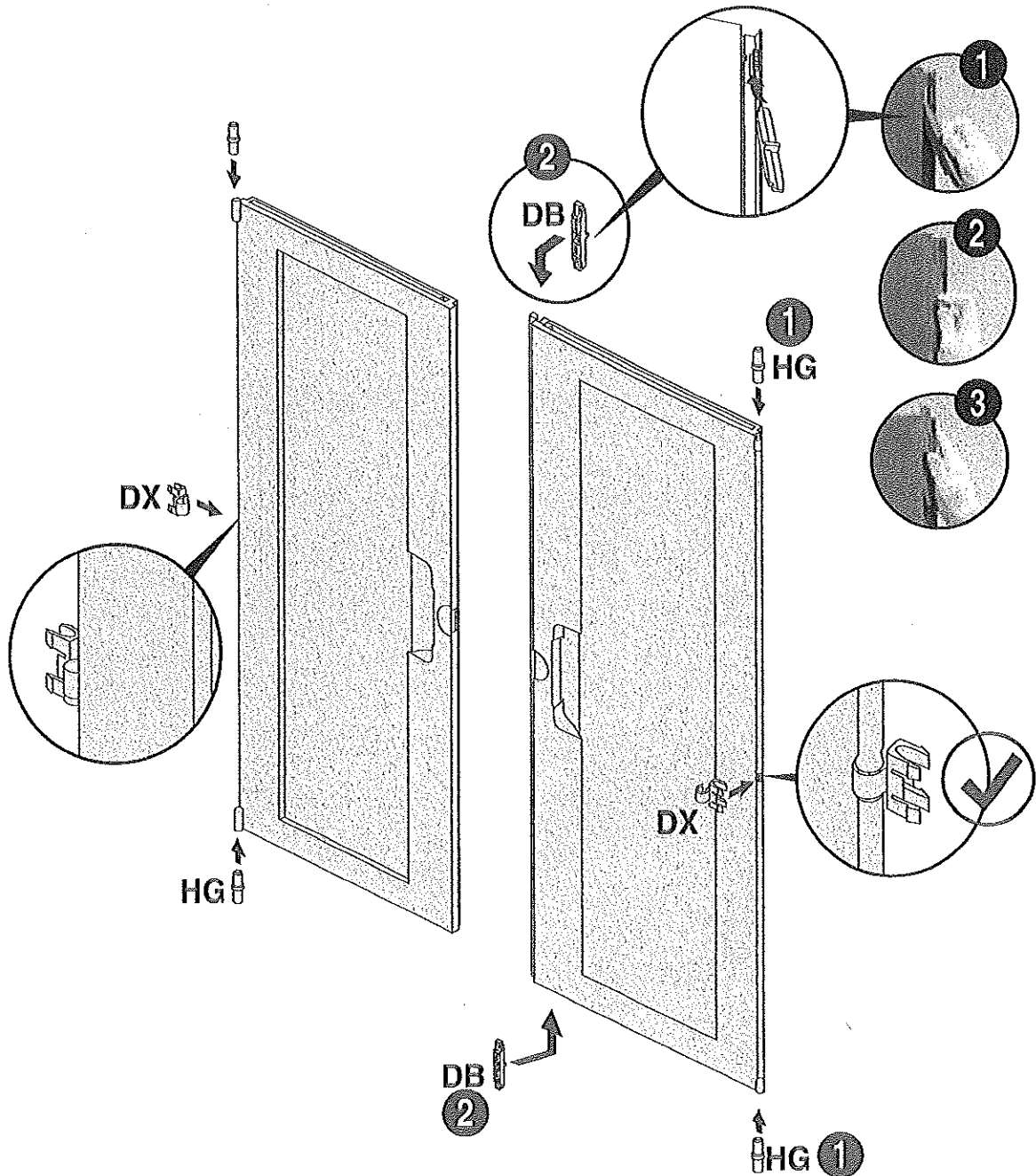
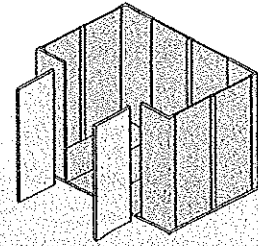

14

ND(x2)

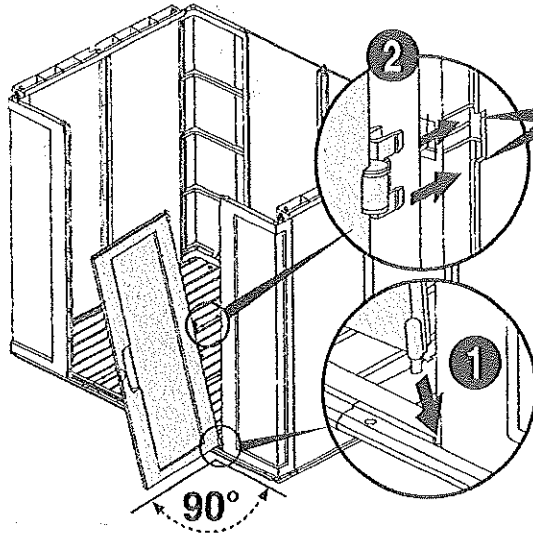
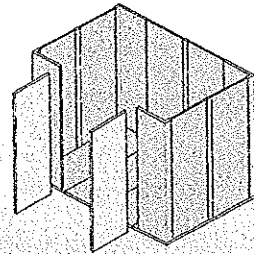

click

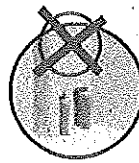
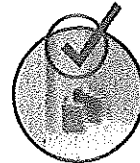
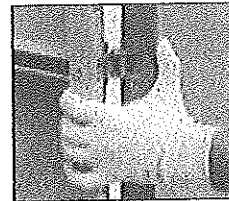

ROOF ASSEMBLY • MONTAGE DU TOIT • DACHMONTAGE • ARMADO DEL TECHO • DAKMONTAGE • MONTAGGIO DEL TETTO • MONTAGEM DO TELHADO

15

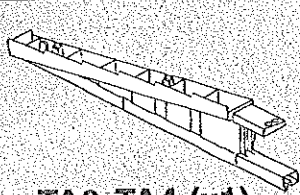

TA3, TA4 (x1)

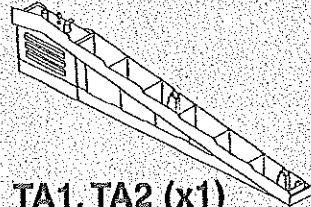

TA1, TA2 (x1)

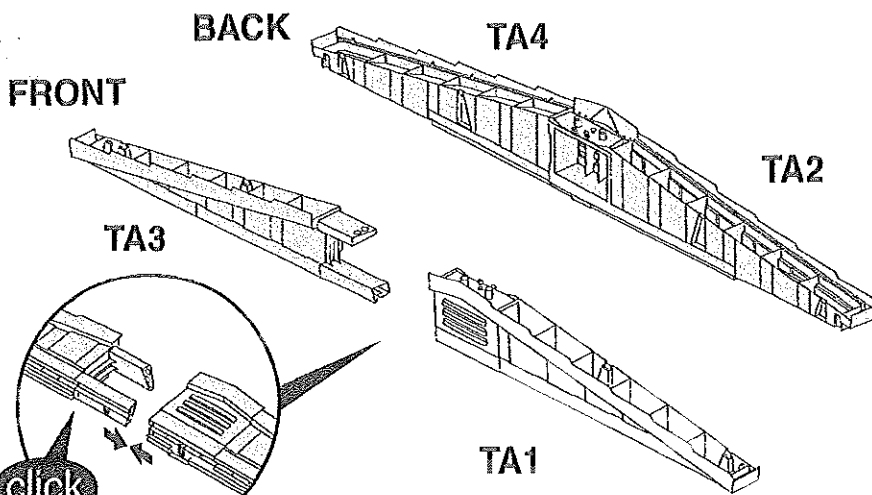
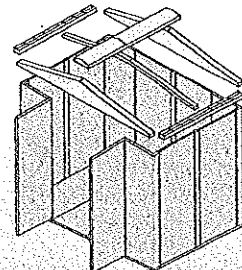

BACK

TA4

FRONT

TA2

TA3

TA1

click

